

Aug. 20, 1968

W. D. WILLIAMS

3,397,858

CONCRETE SLAB FORM PANEL-SUPPORTING BRACKET

Filed April 4, 1966

2 Sheets-Sheet 1

FIG. 1

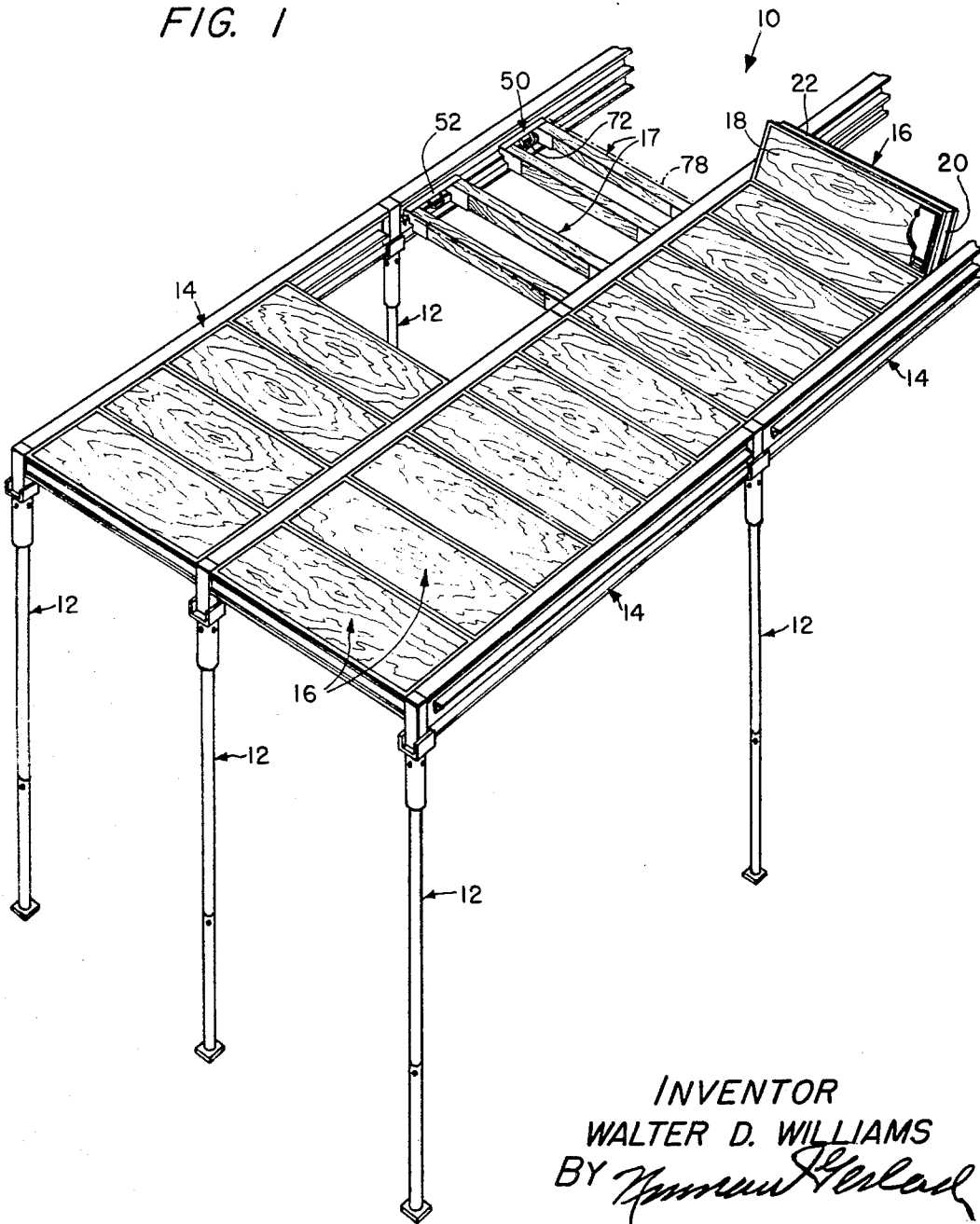

INVENTOR  
WALTER D. WILLIAMS  
BY *Wm. H. H. H. H.*

Aug. 20, 1968

W. D. WILLIAMS

3,397,858

CONCRETE SLAB FORM PANEL-SUPPORTING BRACKET

Filed April 4, 1966

2 Sheets-Sheet 2

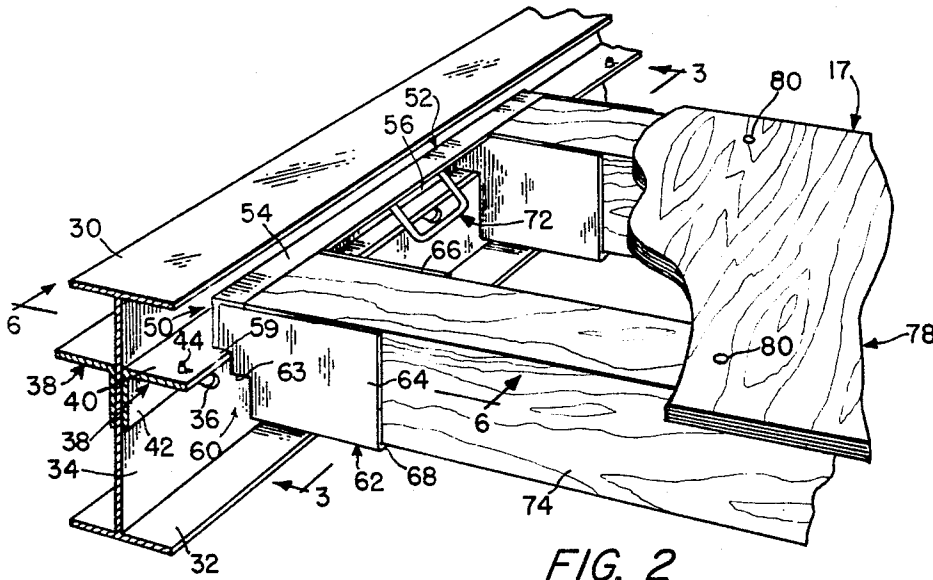

FIG. 2

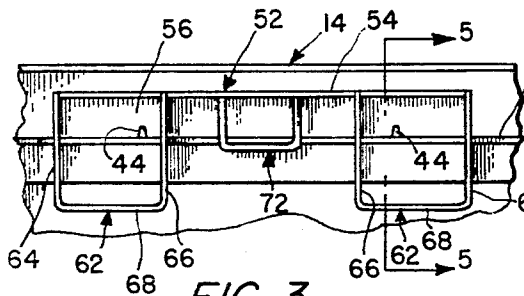

FIG. 3

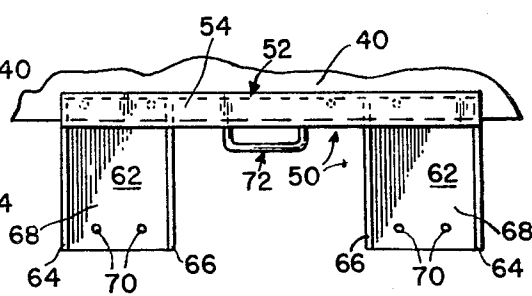

FIG. 4

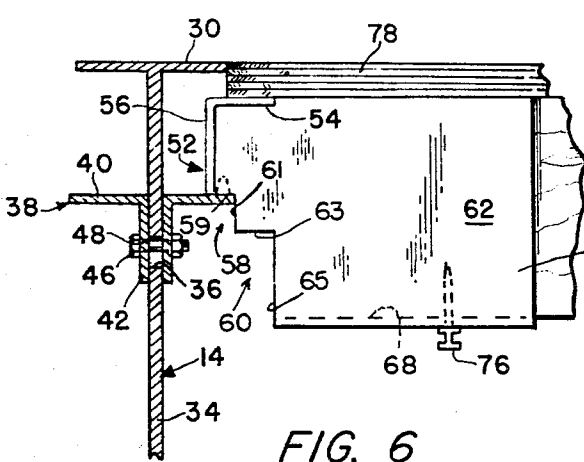

FIG. 6

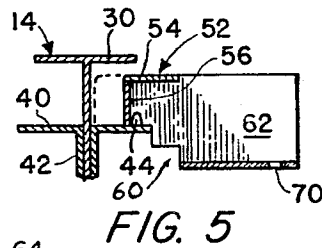

FIG. 5

INVENTOR  
WALTER D. WILLIAMS  
BY *Wm. H. ...*

1

2

3,397,858

**CONCRETE SLAB FORM PANEL-SUPPORTING BRACKET**

Walter D. Williams, River Forest, Ill., assignor to Symons Mfg. Company, Des Plaines, Ill., a corporation of Delaware

Filed Apr. 4, 1966, Ser. No. 539,782  
6 Claims. (Cl. 249-18)

**ABSTRACT OF THE DISCLOSURE**

A panel-supporting bracket assembly which, in combination with an identical bracket assembly, serves to support two wooden beams in parallelism and in bridging relationship with respect to an odd dimension opening between two horizontal "Steel-Ply" panels so that a plywood sheet may be supported on the beams to fill the opening.

The panel-supporting bracket comprising the present invention is designed for use primarily in connection with a panel-supporting stringer assembly of the type which forms the subject matter of United States Patent No. 3,052,008, granted on Sept. 4, 1962, and entitled "Panel-Supporting Stringer Assembly for a Concrete Floor Slab." The stringer assembly, in turn, is designed for use specifically in connection with a particularly system for erecting concrete building structures, the system being illustrated and described in United States Patent No. 3,130,470, granted on Apr. 28, 1964, and entitled "Concrete Wall Form Installation." Still further, the system itself involves the use of special concrete slab form panels which are commonly known as "Steel-Ply" panels and are in the form of prefabricated units like those shown and described in United States Patent No. 2,997,769, granted on Aug. 29, 1961, and entitled "Tie Rod Assembly for Concrete Wall Form Panels." The building erection system, as well as the panel-supporting stringer assemblies and the slab form panels which are employed in connection with the system, have common proprietary ownership in Symons Mfg. Company of Des Plaines, Ill., and the present panel-supporting bracket is useful only in connection with a building erecting system employing stringer assemblies of the type forming the subject matter of said Patent No. 3,052,008. The principal purpose of the present panel-supporting bracket is to enable the system to be used in connection with slab form panels other than "Steel-Ply" panels, specifically flat plywood panels which are of rectangular configuration and unlike "Steel-Ply" panels employ no metallic studding or reinforcing frames.

The development of the present panel-supporting bracket is attributable largely to a matter of economics. Many building contractors have access to, and often own, sources of plywood. When it is considered that, roughly speaking, the current cost of a "Steel-Ply" panel is on the order of two dollars and fifty cents per square foot so that a panel measuring four feet by eight feet costs approximately seventy-five dollars and it is also considered that plywood of a thickness requisite to support a concrete slab costs only on the order of seven cents per square foot, it is not surprising that many contractors who have access to an inexpensive source of plywood take advantage of its availability and substitute plain plywood panels for "Steel-Ply" panels when they are able conveniently so to do. In the building erecting system of afore-

mentioned Patent No. 3,130,470, reliance is placed upon the metallic reinforcing frames of the "Steel-Ply" panels to support the ends of the panels from the special stringer assemblies which are involved in, and form parts of, the system as a whole. Ordinarily, for slab construction work, "Steel-Ply" panels which have standard dimensions of four feet by eight feet are employed. Plain rectangular plywood panels which are of equivalent size and have no metallic reinforcing frames are not sufficiently strong to withstand the load of the concrete which must be poured upon them to produce a slab. Furthermore, the small thickness of a plain plywood panel is only a fraction of the overall thickness of a "Steel-Ply" panel, and thus there are no facilities for adequately supporting a plain plywood panel in position between the adjacent stringer assemblies which, according to the Symons building erecting system, are of special construction. Lack of the ability of a contractor to utilize the plywood which conveniently is available to him in the "Symons" system of building erection involving floor slabs has precluded such contractor from utilizing the system as a whole and, therefore, he has been obliged to content himself with the use of other building erecting systems which will enable him to use his source of plywood but are nevertheless less effective, practical and efficient.

The panel-supporting bracket of the present invention is designed to overcome the above-noted limitation which is imposed upon a contractor who is thus precluded from utilizing plain plywood panels in connection with the "Symons" system of building erection and, toward this end, the invention contemplates the provision of a relatively simple and inexpensive panel-supporting bracket which will adequately support a rectangular sheet of plywood that is dimensioned commensurately with a standard "Steel-Ply" panel; which will correctly position the plywood panel so that its upper face lies flush with the upper face of an adjustable stringer like that of aforementioned Patent No. 3,052,008 in order to produce an unbroken pouring surface for the concrete; which will reinforce the plain plywood panel so that it will adequately support the load; which will enable stripping of the plain panel from the building erecting system as soon as the poured slab has become self-supporting; and which otherwise, by its use, function with the associated plain panel in the manner of a "Steel-Ply" panel in that it requires no deviation from the method steps which are involved in practicing the "Symons" system of concrete building erection.

For a full understanding of the nature of the present panel-supporting bracket, as well as the use to which it is put, it is necessary that the character and mode of operation of the adjustable panel-supporting stringers with which the bracket is associated be thoroughly understood. The adjustable stringer assemblies of a "Symons" building erecting system are so designed as to support a horizontal series of "Steel-Ply" panels so that the upper faces of the plywood facings of the panels are coplanar. The stringers proper of the assemblies when in their operative panel supporting position present upper surfaces which are also coplanar with and constitute an extension of the upper faces of the plywood facings of the panels so that all of the panels and stringers present at the top of the system a continuous uninterrupted planar surface on which the wet concrete is poured for slab-forming purposes. The ends of the "Steel-Ply" panels, instead of being supported on the upper portions of the stringers as is

conventional, are supported upon horizontal angle bars which are movably carried on the sides of the stringers, such stringers being ordinarily in the form of steel I-beams. The ends of the "Steel-Ply" panels rest upon the upper edges or flanges of these bars and the bars are movable between an elevated position where they maintain the panels in exact horizontal register with the top surfaces of the stringers and a lowered position wherein the ends of the panels are dropped below the level of the upper faces of the stringers. Thus, in the lowered position of the angle bars of the stringer assemblies, the ends of the panels are free and, by proper manipulation, the panels may be removed from beneath the partially hardened concrete slab while, at the same time, the position of the stringers in supporting relationship with respect to the slab is not disturbed. The slab thus remains supported during panel-removing operations. By such an arrangement, at no time is there relieved the upward supporting pressure that is exerted by the shores and stringer assemblies of the building erecting system against the underneath face of the concrete slab. The present panel-supporting bracket, when operatively associated with a plain sheet or panel of plywood, produces, in effect, a composite panel structure which may be physically and functionally substituted for a "Steel-Ply" pane, of equivalent longitudinal and transverse dimensions. This structure not only affords a plywood facing which lies in the same plane as the flat upper edges of the stringers upon which the structure is supported, but also is capable of manipulation in the manner of a conventional "Steel-Ply" panel, both in its application to the adjustable stringer assemblies and in its removal therefrom after the poured concrete has become hardened to such an extent that it is self-supporting.

The provision of such a panel-supporting bracket constitutes the principal object of the invention and, in carrying out this object, the invention contemplates the provision of a novel end support or bracket for one end of a plain rectangular sheet or panel of plywood which is to provide a necessary panel facing. This end support or bracket, when used in combination with an identical end support or bracket at the other end of the sheet or panel of plywood, establishes a substitute panel structure for a "Steel-Ply" panel. Each end support or bracket possesses all the physical attributes which are provided at each end of a "Steel-Ply" panel in that it interlocks with the associated adjustable stringer assembly in the same manner as the "Steel-Ply" panel so that it may be applied to and removed from the associated stringer assembly by the same operations that are performed when an end of a "Steel-Ply" panel is applied to and removed from its associated stringer assembly. Additionally, the two end supports or brackets at the ends of the plain plywood sheet or panel afford a pair of cradles for receiving therein the ends of two rectangular wooden beams which may be of the 4" x 4" variety. These beams span the distance between adjacent but spaced apart adjustable stringer assemblies and constitute base supports for the plywood sheet or panel which may be suitably tacked thereto near the corners of the plywood sheet and removed therefrom when the thus constructed substitute panel structure has served its purpose.

It is a further object of the present invention to provide a panel-supporting bracket of the character briefly outlined above which may be constructed in its entirety of conventional steel stock materials such as flat strip stock, angle stock and rod stock, cut to length, bent to shape and all welded together to form the composite unitary rigid bracket of the present invention.

Numerous other objects and advantages of the invention, not at this time enumerated, will readily suggest themselves as the nature of the invention is better understood.

In the accompanying two sheets of drawings forming a part of this specification, one illustrative embodiment of the invention is shown.

In these drawings:

FIG. 1 is a fragmentary perspective view of a typical concrete building erecting system involving the formation of a horizontally disposed concrete slab, and showing a number of "Steel-Ply" panels and a pair of substitute panels employing the panel-supporting brackets of the present invention operatively applied thereto, the different panels being illustrated for purposes of comparison;

FIG. 2 is a fragmentary top perspective view of a portion of such system, the view being taken in the vicinity of one of the panel-supporting brackets of the present invention;

FIG. 3 is a sectional view taken along the vertical plane indicated by the line 3—3 of FIG. 2 and in the direction of the arrows;

FIG. 4 is a top plan view of the structure shown in FIG. 3;

FIG. 5 is a vertical sectional view taken on the line 5—5 of FIG. 3; and

FIG. 6 is an enlarged sectional view taken on the vertical plane indicated by the line 6—6 of FIG. 2 and in the direction of the arrows.

Referring now to the drawings in detail, and in particular to FIG. 1, there is disclosed in this view a typical concrete building erecting system involving a horizontal supporting surface for use in the formation of a concrete slab (not shown) resulting from the pouring of concrete on such surface. The entire system is designated in its entirety by the reference numeral 10 and involves a plurality of vertically disposed shores 12 the upper ends of which serve to support in opposed but spaced apart relation a plurality of horizontally extending adjustable stringer assemblies 14. Such adjustable stringer assemblies, in turn, serve to support the end regions of a horizontal series of transversely disposed panels 16, these panels being in the form of conventional "Steel-Ply" panels. The "Steel-Ply" panels 16 have been disclosed herein solely for purposes of comparison with a substitute panel which is capable of being formed by utilizing two of the brackets of the present invention, together with certain articles of lumber in a manner that will be set forth presently. Each substitute panel that is illustrated in the drawings hereof is designated in its entirety by the reference numeral 17. In erecting the system 10, the shores 12 are set up in the usual manner of erection on sills or bases (not shown) which are positioned upon the ground or other foundation surface and serve to prelocate the vertically disposed shores. It is to be understood that the various shores 12 may be cross-braced in any suitable manner by struts, the latter having been omitted herein since they form no part of the present invention.

The system 10 is merely illustrative of a typical concrete building erecting system in which the shores 12 are arranged in three spaced-apart, longitudinally extending rows and with the panels 16 having their own longitudinal direction extending transversely of the system 10 between the adjacent parallel stringers 14. The panels 16 are conventional "Steel-Ply" panels of the type that is shown and described in aforementioned Patent No. 2,997,769, and they are in the form of shallow rectangular box-like structures of tray-like design. Each panel includes a plywood facing 18 which is bounded by marginal steel frame members including elongated side members 20 and end members 22. "Steel-Ply" panels of this character are made up in standard sizes, specifically in three, four, six and eight foot lengths and in one, one and one-half, two, four, six, eight, ten, twelve, fourteen, sixteen, eighteen, twenty and twenty-four inch widths, any combination of such lengths and widths being available. The side members 20 and end members 22 of each panel constitute a rectangular metal frame or studding for the plywood facing 18.

The adjustable stringer assemblies 14 are of the type shown in the aforementioned Patent No. 3,052,008 and each assembly comprises a stringer proper in the form

of an I-beam (see FIG. 2) having upper and lower horizontal flanges 30 and 32 and an interconnecting vertical web 34. The web 34 of each stringer is provided with a series of arcuate slots 36 at spaced regions longitudinally of the I-beam. On opposite sides of the web of each stringer and in straddling relationship with respect thereto, are two vertically movable, horizontally positioned support bars 38 in the form of angle pieces having horizontal flanges 40 and vertical flanges 42. The horizontal flanges 40 of the support bars of each adjustable stringer assembly project outwardly beyond the lateral extent of upper flange 30 of the I-beam and a series of spaced apart rivets 44 project upwardly from the upper surface of the horizontal flanges 40 near the outer edge thereof. These rivets are provided as a precautionary safety measure to prevent accidental dislodgment of the "Steel-Ply" panels 16 which have their end members 22 resting on the horizontal flanges 40 when the panels are operatively assembled on the support bars 38 of the stringer assemblies. Clamping bolt and nut assemblies 46 project through the slots 36 (see FIG. 6) and also through holes 48 in the vertical flanges 42 of the support bars 38 in order that the movable support bars may be clamped in either a raised or elevated position or a lowered position. The movable support bars are adapted to be clamped in their uppermost position with the end members 22 of the "Steel-Ply" panels 16 supported thereon and lying behind the rivets 44. The various panels 16 when in their operative position bridge the distance between adjacent stringer assemblies 14 and the upper faces of the plywood facings 18 lie in the common plane of the upper flanges 30 of the I-beam stringers so that there is provided a smooth unbroken surface on which wet concrete may be poured for production of a floor slab. In order to remove the panels it is merely necessary to loosen the nut and bolt assembly 46 and lower the support bars 38, whereupon the panels 16 are released for removal purposes. To remove any given panel it is merely necessary to raise the panel until the ends thereof clear the rivets 44 on the horizontal flange 40 of the adjacent support bars 38, after which the panel may be shifted bodily endwise in one or the other direction in order to cause one end of the panel to clear its associated support bar 38. Thereafter, such end of the panel may be lowered and the entire panel pulled out from beneath the partially hardened slab. For a more detailed discussion of the manner in which the "Steel-Ply" panels 16 may be operatively installed in and removed from a concrete building erecting system similar to the system 10, reference may be had to aforementioned Patent No. 3,130,470.

From the above description, it will be apparent that, according to the previously described arrangement of stringer assemblies 14 and "Steel-Ply" panels 16, it is possible to remove the panels 16 while allowing the stringer assemblies 14 to remain their supporting position with respect to the poured concrete slab with the latter resting upon the upper flanges 30 of the I-beams so that at no time is the supporting pressure on the slab relieved except in the limited area which were occupied by the panels prior to removal. Because of this fact, it is possible to resort to panel-removing operations at a comparatively early date after concrete pouring operations have been effected since it is not necessary to wait until the concrete has attained sufficient strength to be self-supporting between stringer assemblies which are twice or three times removed from one another.

It has been suggested previously in the introductory part of this specification, and in considerable detail, that the cost of "Steel-Ply" panels, whether on a rental or a purchase basis, makes it economically expedient for a building contractor who has access to a source of inexpensive lumber to fashion his own panels, utilizing plywood facings and wooden studding. In such an instance, such a contractor heretofore has been precluded from availing himself of the facilities for early panel removal which are offered by the adjustable stringer assemblies 14 of the

system 10. According to the present invention, a novel composite bracket which is designated in its entirety by the reference numeral 50 has been devised and this bracket, when employed in connection with another and identical bracket, together with a sheet or panel of plywood and a pair of wooden beams of the 4" x 4" variety, enables a contractor to fashion in the field a substitute panel such as the panel 17 which, although sacrificing some of the advantages of a regular "Steel-Ply" panel, nevertheless may be functionally and physically substituted for one of the panels 16 in a concrete building erecting system such as the system 10 and which, when so substituted, is capable of removal in the manner previously described from beneath the poured and partially hardened concrete slab while allowing the stringer-type support for the slab to remain intact. Two such substitute panels have been illustrated in FIG. 1 for exemplary purposes, the remaining illustrated panels in the system 10 being of the "Steel-Ply" type. It will be understood, of course, that the disclosure is only for purposes of comparison and in an actual installation all of the various "Steel-Ply" panels 16 will be replaced by corresponding substitute panels 17.

The details of the present panel-supporting brackets 50 are disclosed in FIGS. 2 to 6, inclusive, only one such bracket 50 being illustrated in FIG. 2 at one end of the substitute panel 17. It will be understood, of course, that the other end of the panel has associated therewith an identical panel-supporting bracket 50.

The panel-supporting bracket 50 of FIGS. 2 to 6, inclusive, is of unitary welded four-piece construction and it involves in its general organization a horizontally extending angle bar 52 having a horizontal flange 54 and a vertical flange 56. The end portions of the angle bar 52 have welded thereto similar U-shaped cradle structures 62. These cradle structures have outer sides 64, inner sides 66 and bottoms or bases 68. The cradle bases 68 are provided with nail-receiving holes 70 therein, the purpose of which will be made clear presently. Said cradle bases 68 are spaced forwardly from the vertical flange 56 of the angle bar 52 an appreciable distance so that portions of the cradle sides 64 and 66 overhang these bases in an inward direction, i.e., in a direction toward the angle bar 52. These overhanging portions are cut away to provide upper notches 58 (see FIG. 6) which present downwardly facing horizontal supporting shoulders 59 and vertical shoulders 61, and lower notches 60 presenting downwardly facing shoulders 63 and a vertical shoulder 65. A U-shaped handle 72 has its end regions welded to the underneath side of the horizontal flange 54 of the angle bar 52 and projects downwardly and inwardly therefrom at an angle of approximately 45°, the handle being substantially centrally located on the angle bar 52.

To construct one of the substitute panels 17, two pieces of lumber in the form of 4" x 4" lumber stock are cut to provide a pair of beams 74. The opposite ends of these beams are caused to be seated within corresponding cradles 62 of a pair of opposed brackets 50, and thereafter dual-headed nails 76 are driven upwardly into the end regions of the beams through the small holes 70 in the bases 68 of the cradles 62 in order fixedly to secure the ends of the beams in the cradles. The two brackets 50 and the two beams 74, when assembled in the manner just described, constitute a skeleton structure for one of the substitute panels 17. This skeleton structure may be operatively installed in the building erecting system 10 in the same manner as the installation of a "Steel-Ply" panel 16, the installation being effected by causing one of the brackets 50 to be supported on the horizontal flange 40 of one of the movable support bars 38 with the various downwardly facing shoulders 59 resting on the horizontal flange 40 of the support bar, and with the outer edge of the support bar 38 bearing against the vertical shoulder 61. Thereafter, the skeleton structure may be raised to a substantially horizontal position until the level of the shoulders 59 at the other end of the skeleton structure is at least as high as the adjacent movable support bar 38,

7

after which the entire assembly may be slid to a position wherein the lower edges of the vertical flanges 56 of the angle bars 52 and the various shoulders 59 come to rest upon the two opposed angle bars 38 as shown in FIGS. 5 and 6. In this position of the skeleton structure, the various shoulders 61 engage the outer edges of the angle bars 38 and stabilize the stringer assemblies 14 by preventing them from tilting inwardly toward each other. The lower edges of the vertical flanges 56 lie behind the rivets 44, thus insuring against possible slipping of the brackets 50 from the supporting ledges that are offered by the angle bars 38, and also preventing spreading of the stringers laterally away from each other. Such application of the skeleton structure may be made by a workman from beneath the level of the stringers.

The lumber stock of which the beams 74 are formed is cut to a predetermined length so that the beams afford the necessary clearance at their ends for such endwise shifting of the skeleton structure in either direction. After the skeleton structure, including the two brackets 50 and the two beams 74, has thus become supported upon the two vertically movable or adjustable support bars 38, such bars are shifted to their raised positions and clamped in such positions by the nut and bolt assemblies 46. With the skeleton structure thus supported upon the elevated support bars 38, a rectangular sheet or panel of plywood 78, the longitudinal and transverse dimensions of which correspond to the dimensions of the plywood facing of a conventional "Steel-Ply," is then centered upon the skeleton structure so that it rests upon the upper faces of the two beams 74 and is caused to fit snugly between the opposed inner longitudinal edges of the two upper flanges 30 of the parallel I-beam type stringers between which the installation is made. The plywood sheet or panel 78 will overhang the outer edges of the parallel beams 74 a slight distance as shown in FIG. 2 and the transverse end edges of the panel 78 will overlie and conceal the horizontal flanges 54 of the angle bars 52. A few small nails 80 may be driven through the panel 78 at appropriate widely spaced regions, thus securing the panel to the beams to the end that it is held against lateral shifting with respect thereto. In the final operation of erecting the system 10, the various substitute panels 17 may be slid sidewise longitudinally on the supporting flanges 40 until the various opposed edges of the plywood panels 78 meet each other and form a smooth continuous unbroken planar slab-supporting surface on which wet concrete is adapted to be poured.

After a given building erecting system employing the substitute panels 17 has served its purpose and the concrete of the poured slab has become partially hard but self-supporting, the substitute panels 17, including the brackets 50 and the beams 74 may be individually removed in the manner previously set forth in connection with the removal of standard "Steel-Ply" panels 16. After the support bars 38 have been lowered so as to drop the series of substitute panels 17 a slight distance, an individual panel may be removed by raising one end thereof and sliding such end thereof endwise on the shoulders 63 and away from the rivets 44 on the associated flange 40, raising the other end of the substitute panel above the level of the rivets at that end of the panel, shifting the panel endwise so that the raised end thereof clears the adjacent flange 40, lowering such end and, finally, lifting the other end of the substitute panel from the associated flange 40, thus freeing the panel for removal from the system. During these operations the two handles 72 facilitate handling of the substitute panels.

The substitute panels 17 which utilize the brackets 50 of the present invention as a basis for their assembly are capable or reuse in a succeeding building erecting system or at a different location in the same system. They are also capable of ease of dismantlement since only a very few nails 80 are employed to secure the plywood panels 78 on the beams 74. Similarly, the use of dual-headed

8

nails such as the nails 76 facilitate removal of the ends of the beams 74 from the cradles 62. The lumber stock that is used in the assembly of the substitute panels 17 may thus be salvaged for use in the assembly of other substituted panels either of the same size or of a smaller size.

The invention is not to be limited to the exact arrangement of parts shown in the accompanying drawings or described in this specification as various changes in the details of construction may be resorted to without departing from the spirit or scope of the invention. Therefore, only insofar as the invention has particularly been pointed out in the accompanying claims is the same to be limited.

Having thus described the invention what I claim as new and desire to secure by Letters Patent is:

1. In a concrete slab form system, the combination with a pair of horizontally extending, elongated panel-supporting stringers disposed in spaced apart parallel relationship, each stringer including a vertically shiftable horizontally disposed support bar movable between an elevated and a lowered position and presenting an upwardly facing panel-supporting ledge thereon, and means for releasably securing said bar in its raised position, of a panel-supporting frame structure bridging the distance between adjacent stringers and having its opposite ends resting upon the ledges of the two stringers, said frame structure comprising a pair of elongated beam-supporting brackets, one for each stringer, removably supported on said ledges respectively and coextensive with a limited portion thereof, portions of said brackets at each end thereof overhanging said ledges, cradle structures supported from said overhanging portions and projecting below the level of said ledges, a pair of beams extending between the corresponding cradles of the two support bars and having their opposite ends seated in the cradles, and a horizontal rectangular panel supported upon said beams and bridging the distance between said stringers.

2. In a concrete slab form system, the combination set forth in claim 1 and wherein each beam-supporting bracket includes an angle bar providing a vertical flange and a horizontal flange, the overhanging portions of the bracket are in the form of outer side flanges at the ends of the angle bar, the inner side flanges spaced inwardly from the ends of the bar, and said cradle structures comprise upright U-shaped members formed from flat sheet metal stock having vertical outer sides secured to and supported from said outer side flanges, inner vertical sides secured to and supported from said inner side flanges, and flat horizontal connecting base portions, there being nail holes in said base portions, and nails projecting through said holes and into the end regions of the beams for securing said end regions within the cradles.

3. In a concrete slab form system, the combination set forth in claim 1 and wherein each beam-supporting bracket includes an angle bar providing a vertical flange and a horizontal flange, said vertical flange resting upon an adjacent ledge, and a plurality of upstanding protuberances formed on each ledge behind which said vertical flange normally rests on the adjacent ledge.

4. In a concrete slab form system, the combination set forth in claim 1 and including, additionally, U-shaped handles formed of rod stock, having their ends secured to said beam-supporting brackets medially of their ends, and depending below the level of the associated ledges.

5. In a concrete slab form system, the combination set forth in claim 1 and wherein each beam-supporting bracket includes an angle bar providing a vertical flange and a horizontal flange, and wherein the overhanging portions of each bracket are in the form of outer side flanges at the ends of the angle bar, and inner side flanges spaced inwardly from the ends of the bar, said cradle structures comprising upright U-shaped members formed from flat sheet metal stock having vertical outer sides secured to and supported from said inner side flanges, inner vertical sides secured to and supported from said inner flanges, and flat horizontal connecting base portions having holes

9

therein, nails projecting through said holes and into the end portions of the beams for securing the latter within the cradles, said vertical flanges of the angle bars resting upon adjacent ledges whereby the brackets and beams supported thereby are movable bodily with the support bars.

6. In a concrete slab form system, the combination set forth in claim 5 and including, additionally, a handle formed of rod stock, bent to U-shaped form and having its ends secured to the horizontal flange of each angle

10

bar centrally thereof and depending below the level of the associated ledge upon which the angle bar rests.

## References Cited

## UNITED STATES PATENTS

1,942,093	1/1934	Goldsmith et al. ---	249—210 X
3,130,470	4/1964	Bowden et al. -----	249—192

J. SPENCER OVERHOLSER, *Primary Examiner*.

D. W. JONES, *Assistant Examiner*.