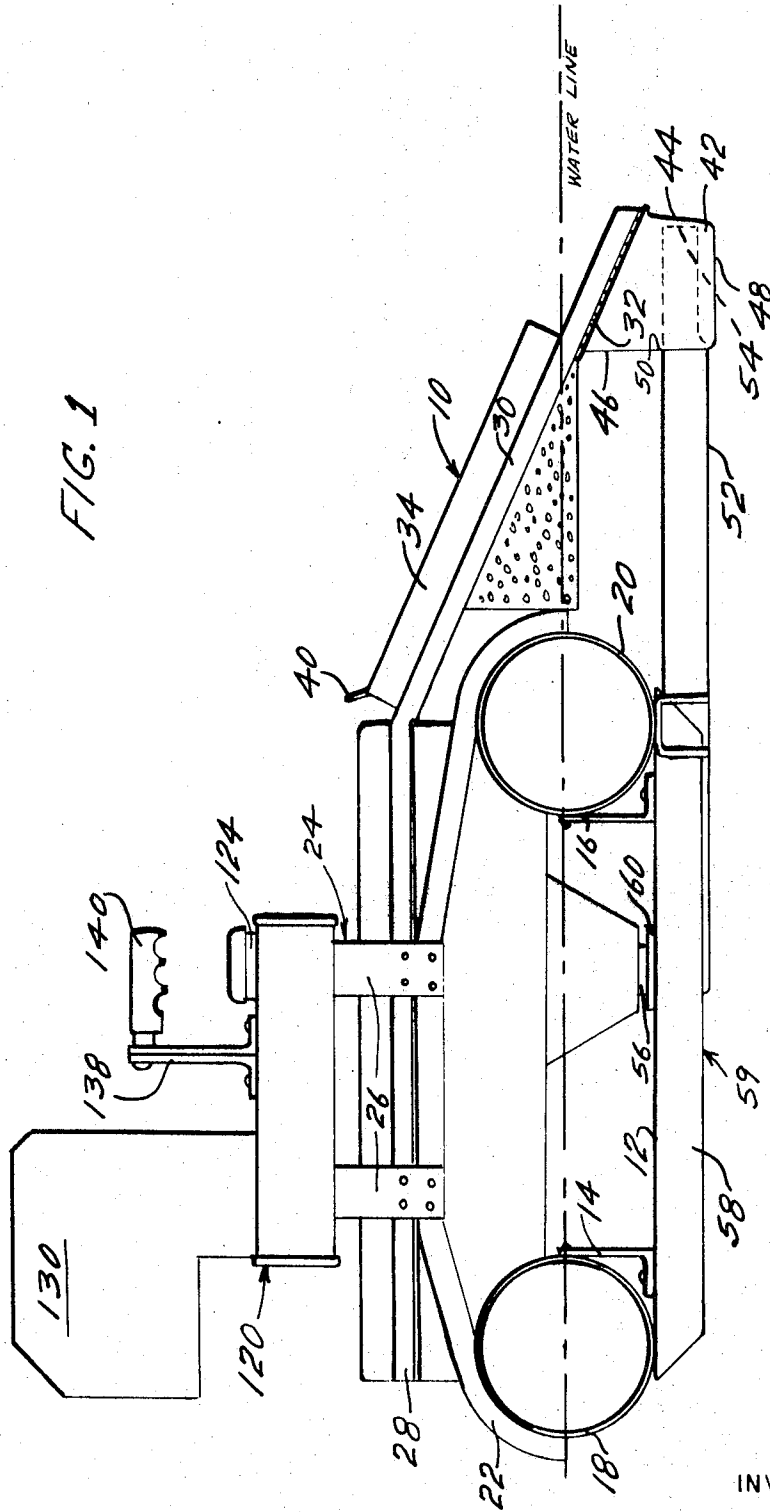

FIG. 1



INVENTORS
HARRY E. SMITH
LEO A. SMITH

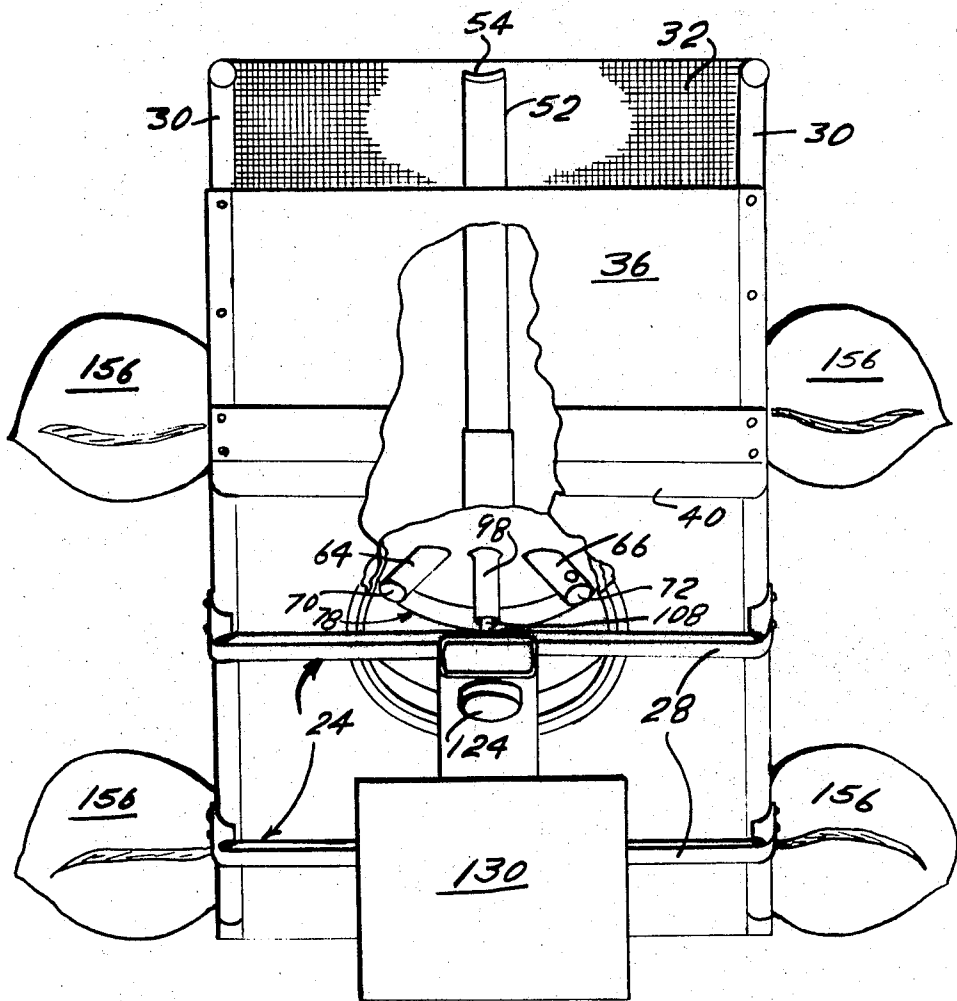
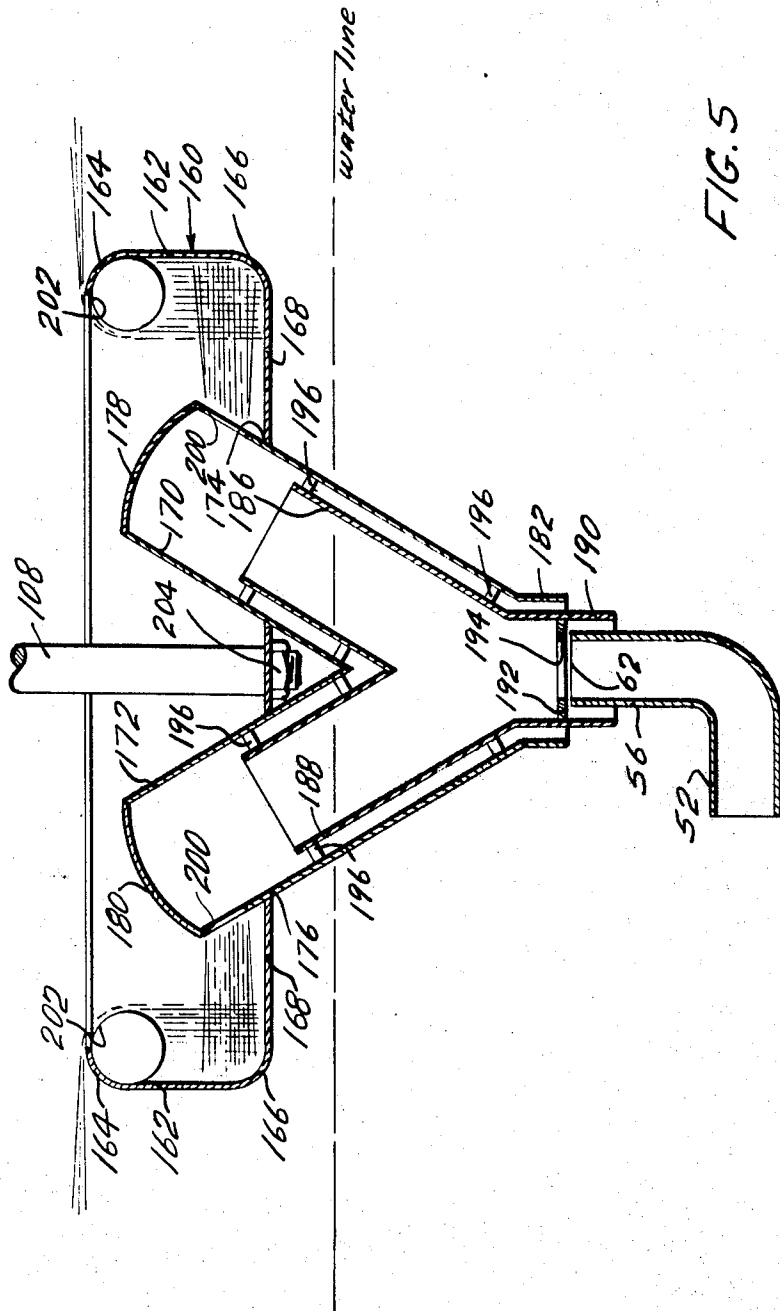

FIG. 2

HARRY E. SMITH INVENTOR
BY LEO A. SMITH
TJW Secret



INVENTORS
HARRY E. SMITH
LEO A. SMITH

FIG. 6

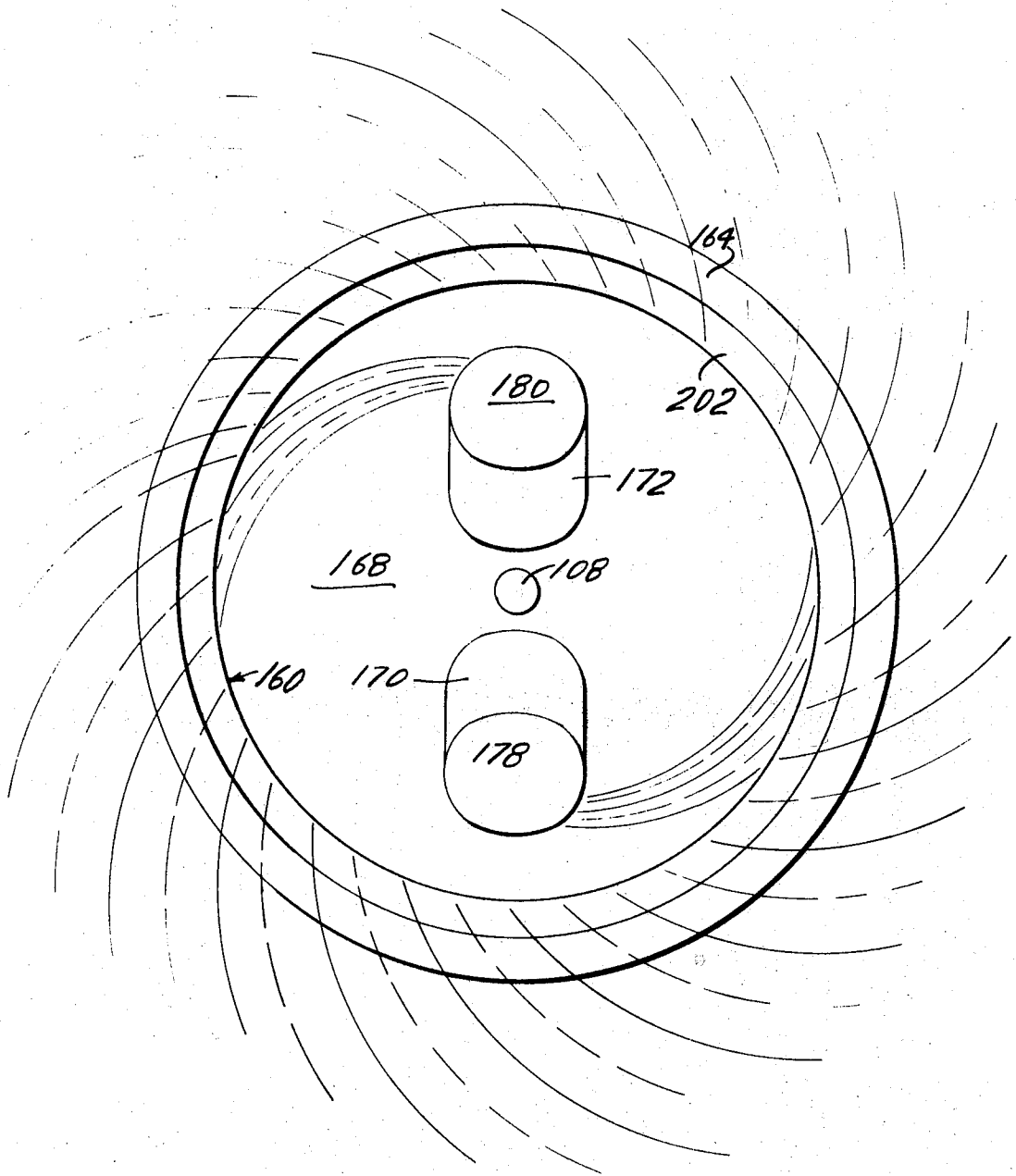

Harry E. Smith INVENTOR
Leo A. Smith
BY
JW Seaver

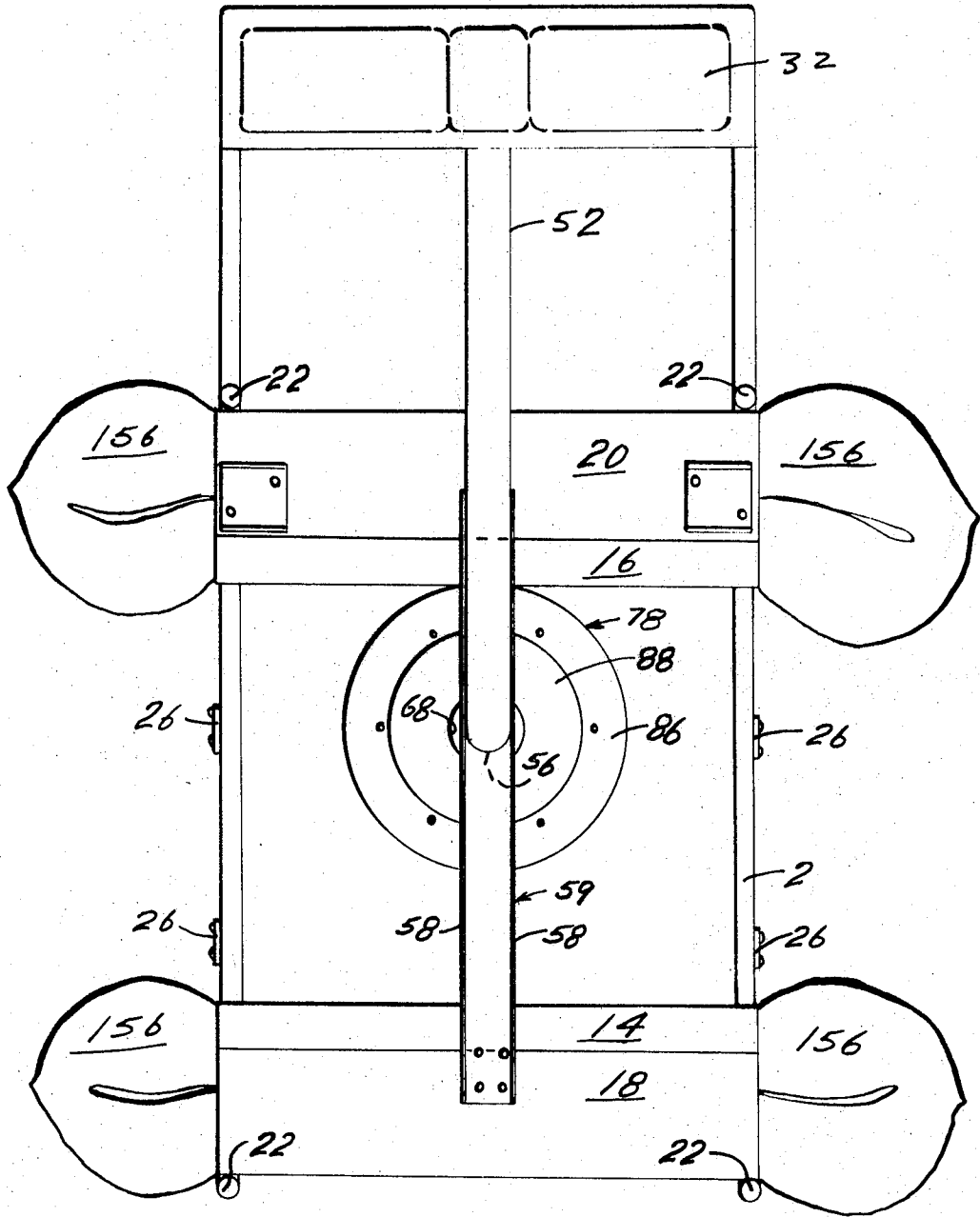

FIG. 7

INVENTOR
Harry E. Smith
BY Leo A. Smith
TW Serrest

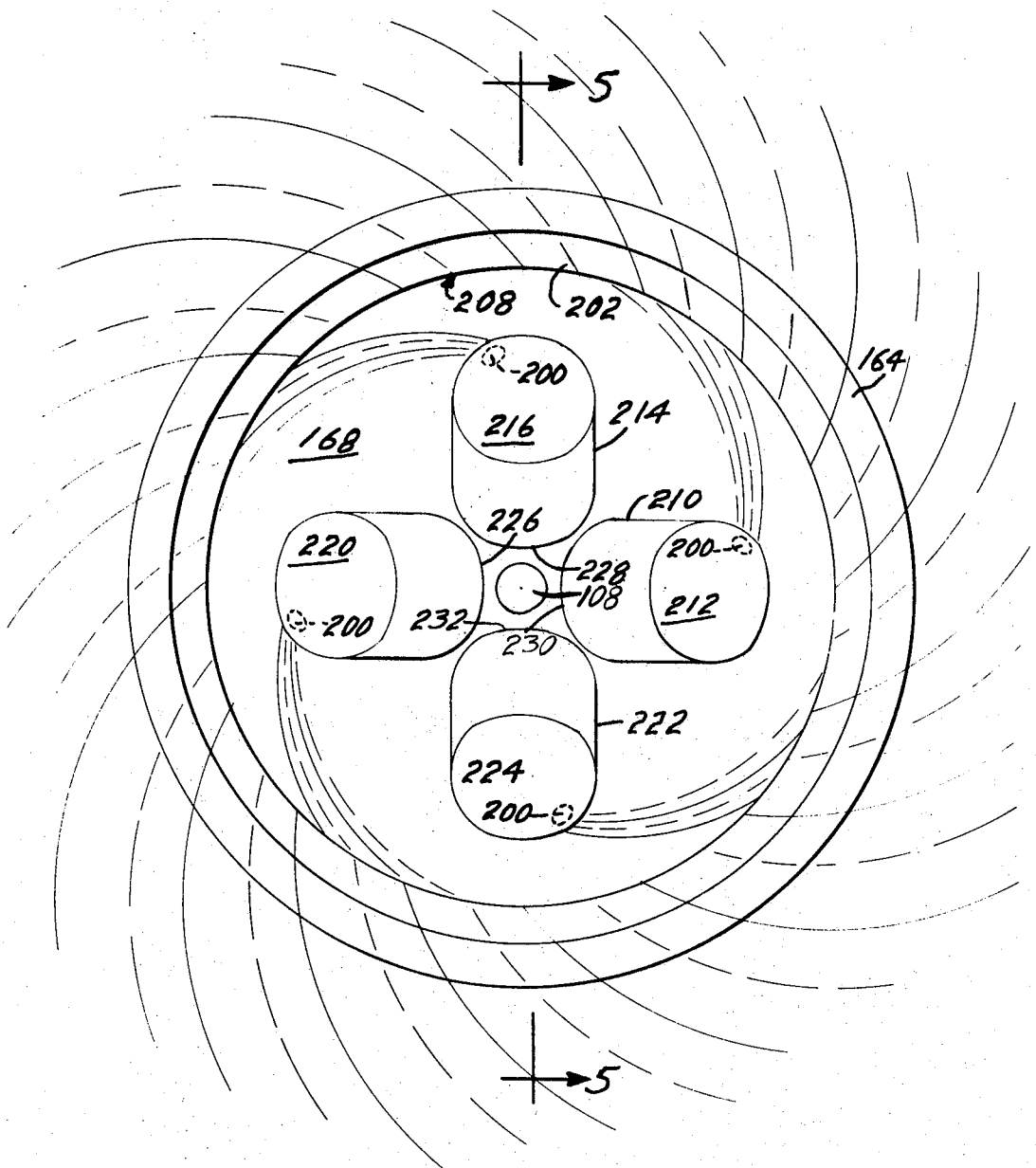

FIG. 8

INVENTOR.
Harry E. Smith
Leo A. Smith
BY
TW Secret

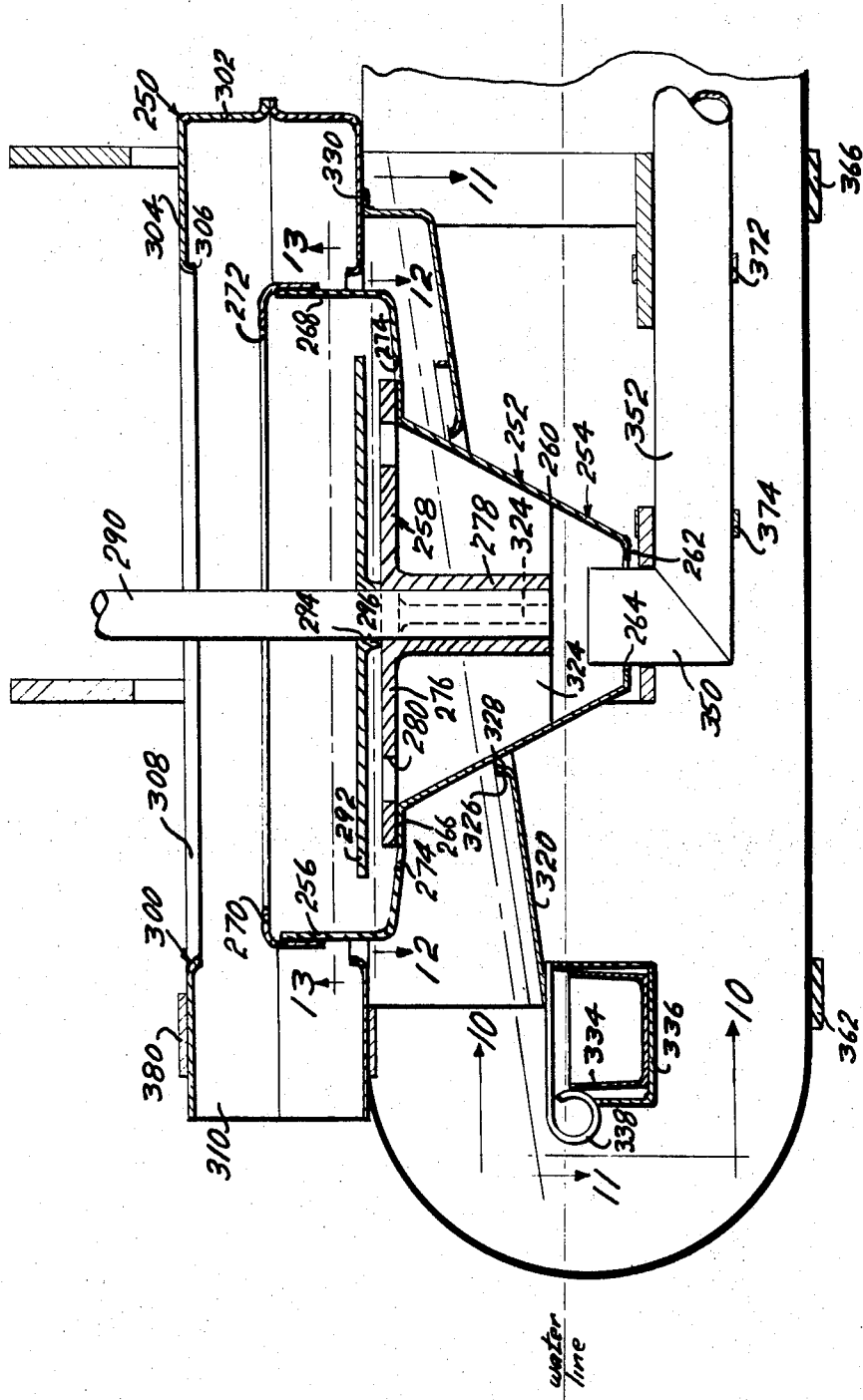

FIG. 9

INVENTOR.
Harry E. Smith
BY Leo A. Smith
TW Secret

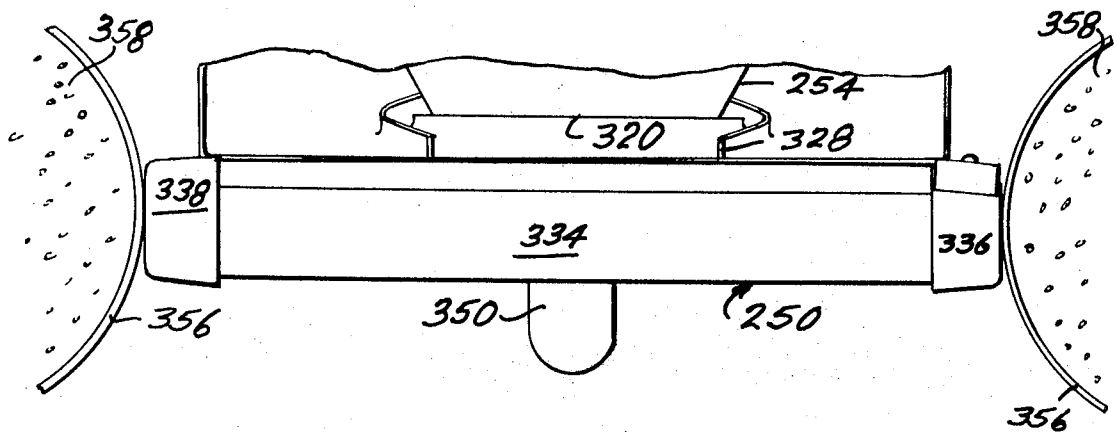

FIG 10

INVENTOR.
Harry E. Smith
Leo A. Smith
BY TW Savest

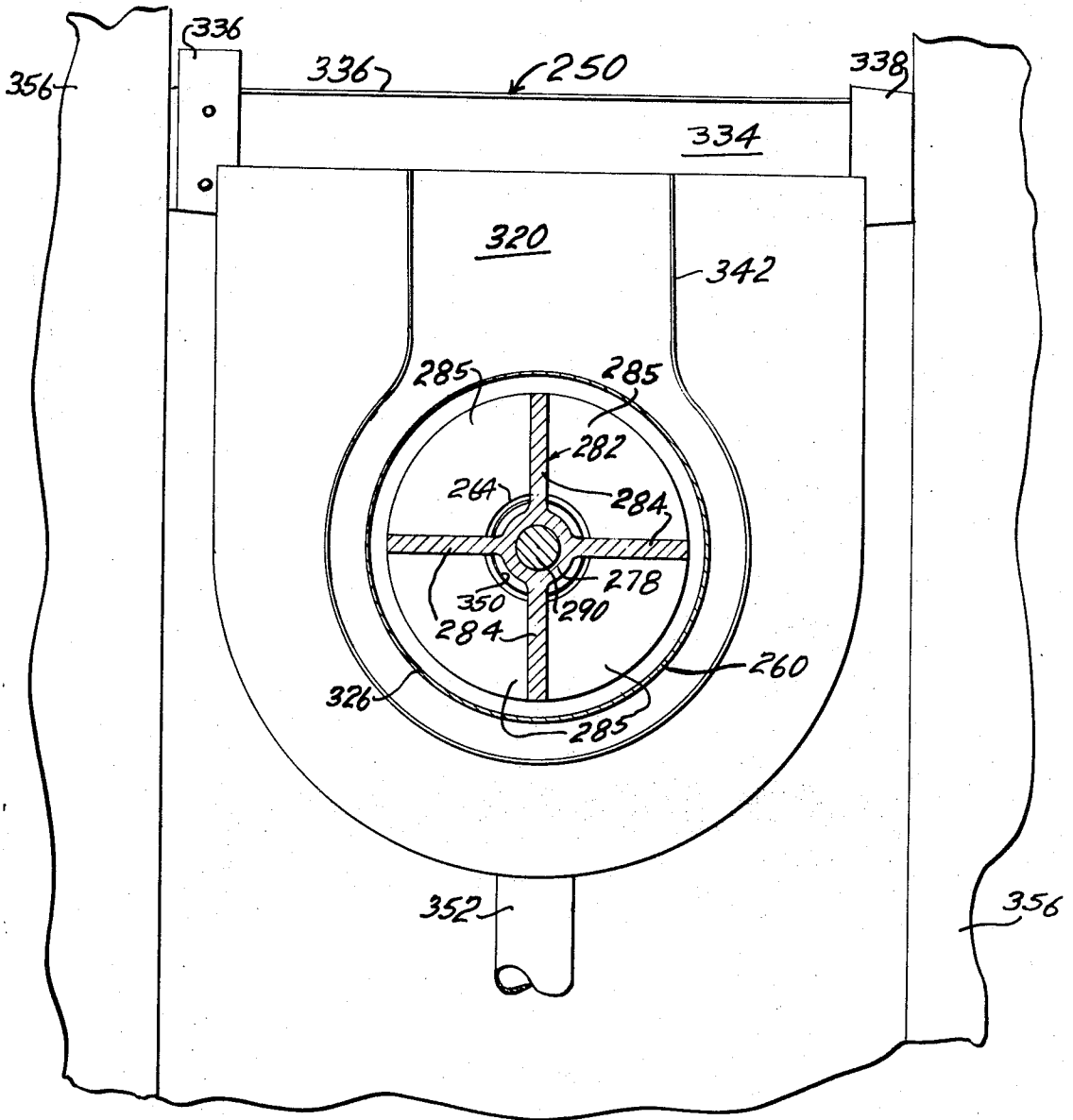

FIG. 11

INVENTOR.
Harry E. Smith
BY Leo A. Smith
TWSerret

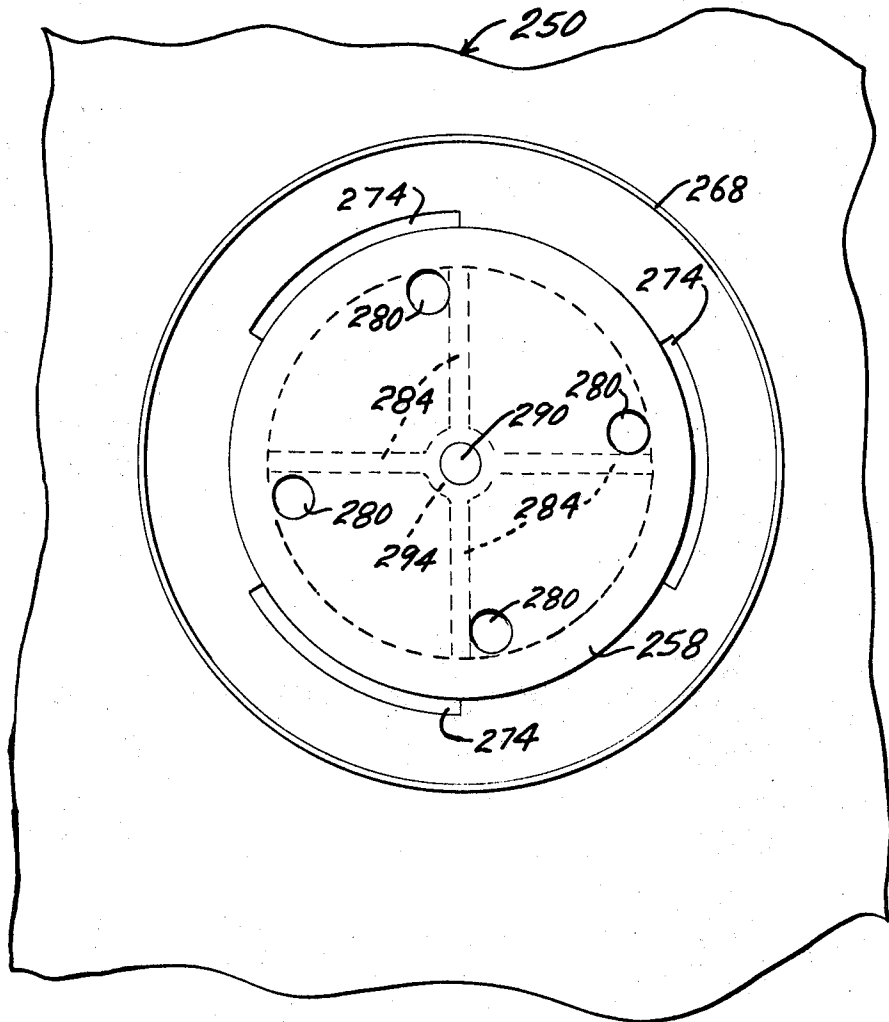

FIG. 12

INVENTOR,
Harry E. Smith
BY Leo A. Smith
T W Sevest

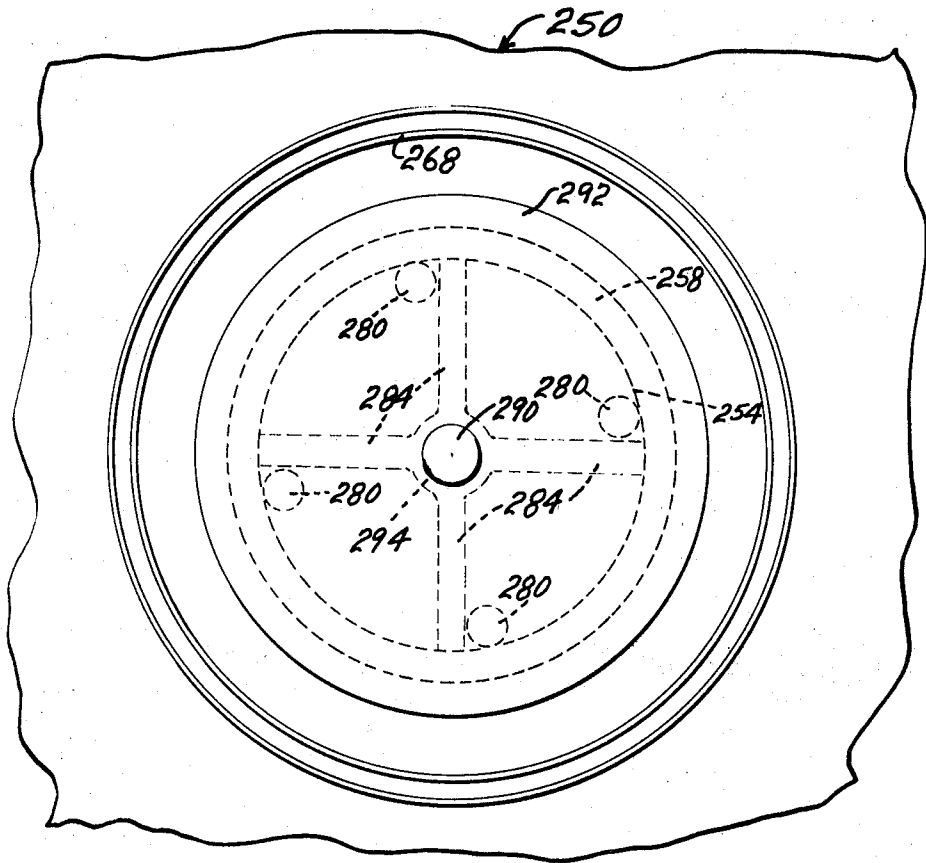

FIG. 13

INVENTOR.
Harry E. Smith
Leo A. Smith
BY
TW Sevest

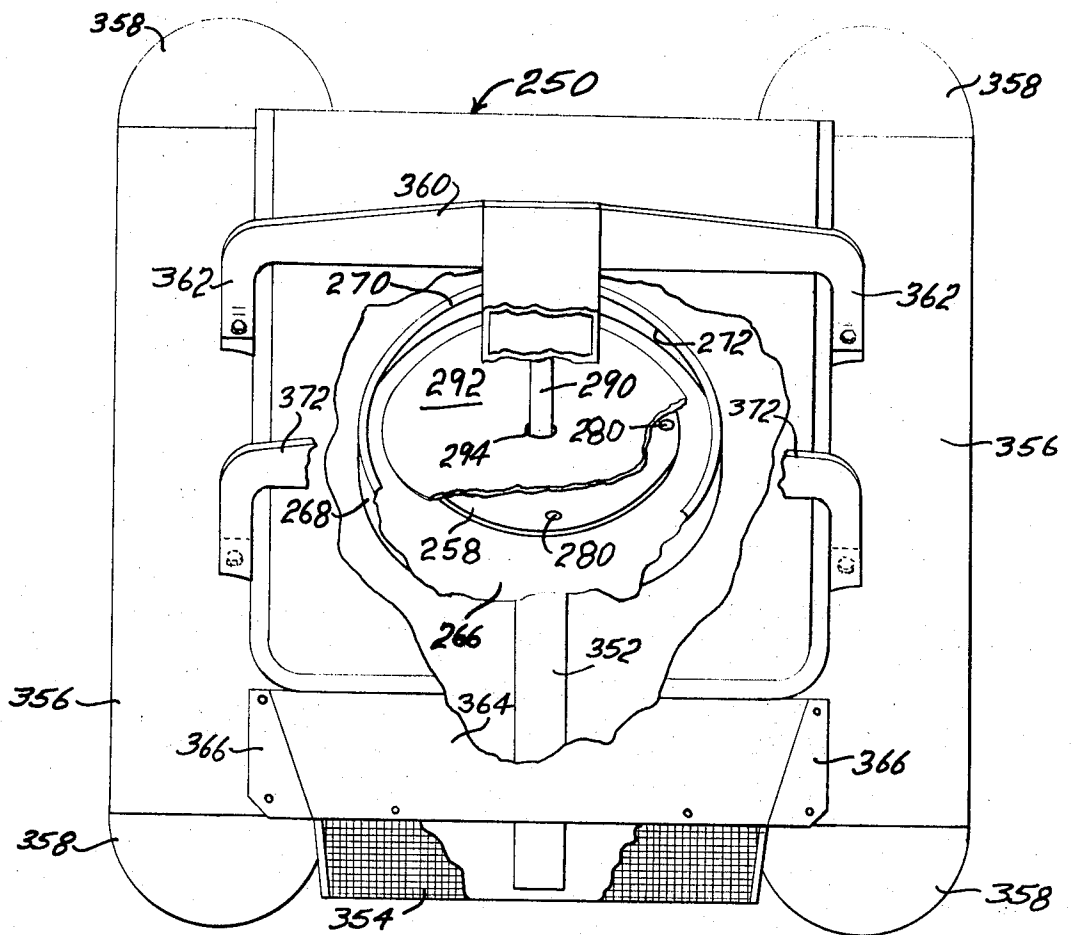

FIG 14

Harry E. Smith INVENTOR.
Leo A. Smith
BY
TWSevest

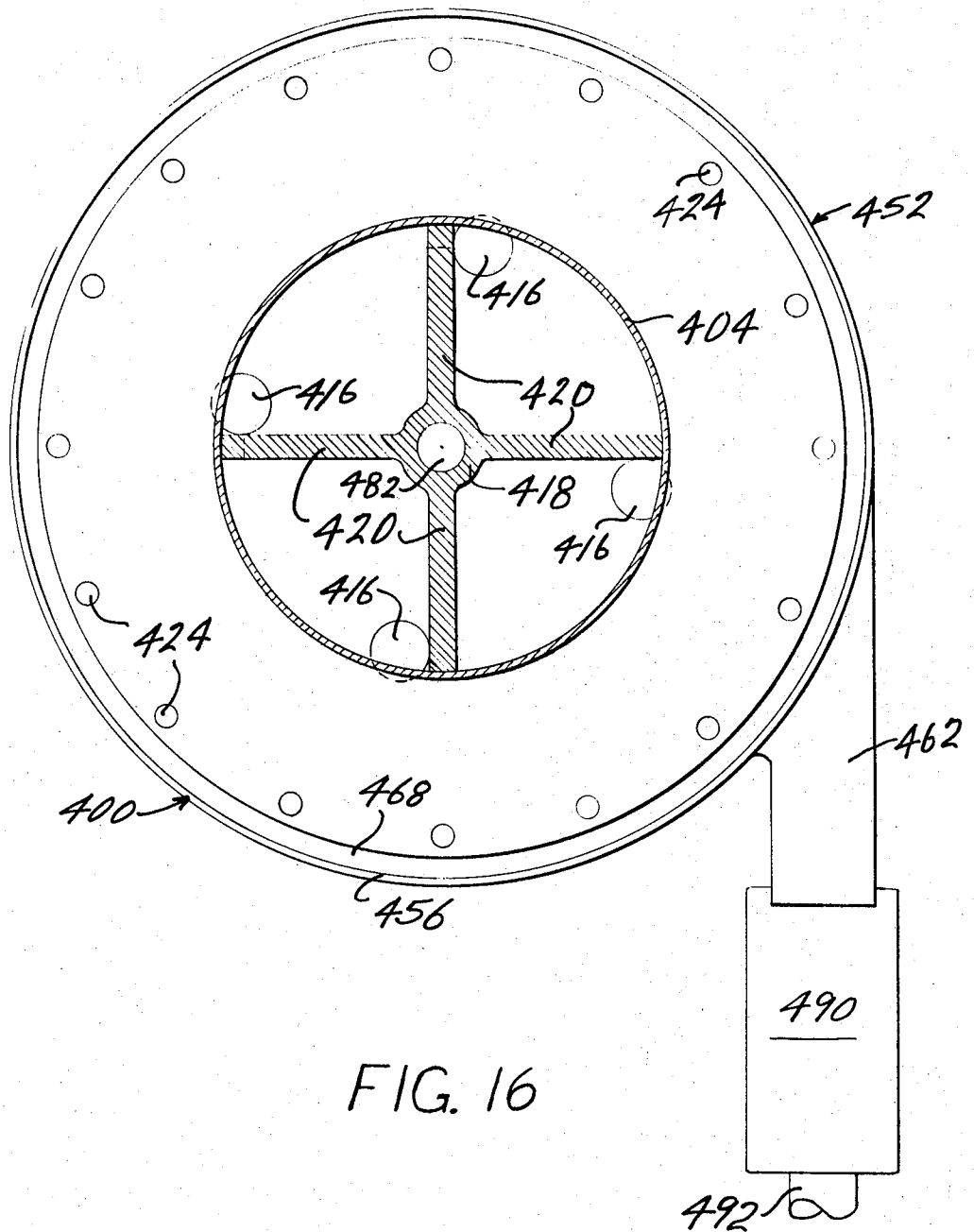
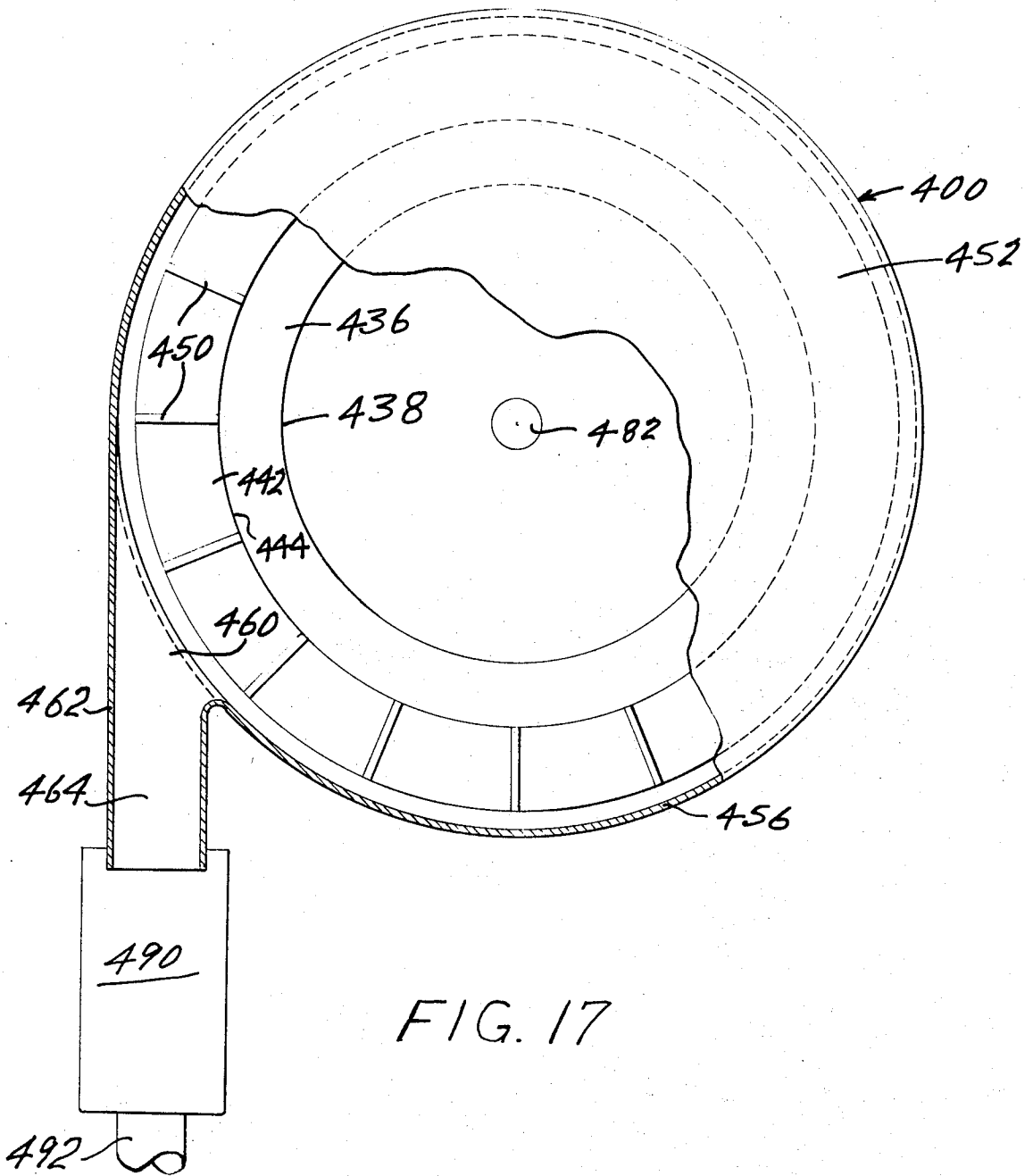

FIG. 16

INVENTOR.
Harry E. Smith
BY Leo A. Smith
TW Secret



INVENTOR.
Harry E. Smith
BY Leo A. Smith
TW Secret

ORE CONCENTRATOR

This invention is for a concentrator to concentrate ore so as to recover valuable elements and compounds, and is a continuation-in-part of our previously filed patent application entitled ORE CONCENTRATOR, filing date of Oct. 30, 1964, Ser. No. 407,629 now abandoned.

One of the objects of this invention is to provide an efficient apparatus for concentrating ore; to provide an apparatus which is light in weight, small in volume, and may be transported by one man; to provide such an apparatus having relatively few moving parts and which may easily be maintained in operating condition; and, to provide such an apparatus which is inexpensive to manufacture.

Further, important objects of this invention are to provide an apparatus for continuously separating the heavier solid from the lighter solid and liquid; to provide such an apparatus having a means for collecting the heavier solid so as to easily and quickly remove the heavier solid from the apparatus; and, to provide an apparatus which is capable of separating a liquid from a solid on a continuous basis so as to purify the liquid from the solid.

These and other important objects and advantages of the invention will be more particularly brought forth upon reference to the detailed specification of the invention, the claims in the application, and the accompanying drawings.

In the drawings:

FIG. 1 is a side elevational view of the specific embodiment of the invention as constructed in accordance with the preferred teaching thereof;

FIG. 2 is a plan view looking down on the invention and with parts of the invention broken away to more clearly illustrate some of the features;

FIG. 3 is a longitudinal, vertical, cross-sectional view of the invention and shows details of construction of the same;

FIG. 4, on an enlarged scale, is a longitudinal vertical cross-sectional view showing details of the construction of the pan and ore concentrator;

FIG. 5, taken on line 5-5 of FIG. 6 (or FIG. 8), is a longitudinal vertical cross-sectional view of another embodiment of the pan and ore concentrator;

FIG. 6 is a plan view looking down on the pan and ore concentrator similar to that of FIG. 5 but having two tubes instead of four tubes;

FIG. 7 is an underneath plan view looking up at the invention of FIG. 2;

FIG. 8 is a plan view looking down on the pan and ore concentrator of FIG. 5 and shows four outlet tubes;

FIG. 9 is a longitudinal vertical cross-sectional view of another specific embodiment of the invention which is constructed in accordance with the preferred teachings thereof and illustrates an apparatus capable of continuously separating a heavier solid from a lighter solid and a liquid and for collecting the heavier solid;

FIG. 10, taken on line 10-10 of FIG. 9 is a lateral vertical cross-sectional view looking at the collection box and the rotating separating apparatus;

FIG. 11, taken on line 11-11 of FIG. 9, is a fragmentary inclined cross-sectional view illustrating the rotating apparatus, the collection box and the chute leading to the collection box;

FIG. 12, taken on line 12-12 of FIG. 9, is a horizontal, fragmentary cross-sectional view illustrating the rotor and the holes in the rotor slots in the bottom of the pan;

FIG. 13, taken on line 13-13 of FIG. 9, is a horizontal, fragmentary cross-sectional view of the pan and is looking down on the baffle plate;

FIG. 14, is an isometric view looking up at a fragmentary portion of the latter part of the pan, the rotor, the baffle plate and the inlet screen;

FIG. 15 is a vertical lateral cross-sectional view of a water purifier and illustrates the rotor and the cap for directing the purified water away from the rotor;

FIG. 16, taken on line 16-16 of FIG. 15, is a longitudinal horizontal fragmentary view looking upwardly at the divider between the pan and the housing of said rotor in the water purifier; and

FIG. 17 is a fragmentary plan view looking down on the cap or cover of the water purifier and a portion of the cap broken away to show the part of the rotor of the water purifier.

In the drawings it is seen that there is an ore concentrator 10 having a flat frame member 12 and two lateral spaced apart angles 14 and 16. The angle 14 is attached to the flat plate member 12 near the rear of 12 and the angle 16 is attached to the flat plate member 12 near the front of the plate member. These angles may be attached by means of rivets, bolts, or by welding, or by any convenient standard means for attaching the angle. Attached to the rear of the angle 14 and also to the rear part of the member 12 is a cylindrical tube 18. Attached to the front of the angle 16 and also to the front of the member 12 is a cylindrical tube 20. The cylindrical tubes 18 and 20, and the angles 14 and 16 run laterally across the member 12. On each side and on top of the two cylindrical members 20 there is attached a tubular member 22. This tubular member runs from the back of the cylindrical member 18, upwardly, then downwardly, and over the front of the cylindrical member 20. Attached near the central portion of the tubular members 22 are two spaced apart lateral braces 24 having a depending leg 26 on each side and a flat middle portion. The tubular members 22 may be attached to the cylindrical members 18 and 20 by welding and the brace members 24 may be attached to the tubular members 22 by rivets, bolts, and/or welding. On each side of 10 there is a longitudinal member having a straight section 28 which overlies the tubular members 22, and has a downwardly depending section 30 which projects forwardly of the cylindrical member 20. The straight section 28 may be attached to the legs 26 by means of rivets, bolts, or welding, or other suitable mechanical means. Between the two members 30 there is positioned a screen 32. This screen may extend all the way from the lower end of the member 30 to the upper end of the member 30 or substantially where the member 30 meets the member 28. Overlying the upper part of the member 30 and also the screen 32 there is a housing having sides 34 which connect with the member 30 and a flat portion 36. The flat portion 36 covers most of the screen although there is a lower portion of the screen exposed, say the lower fifth of the screen is exposed. In the housing 30 there is a baffle 38 having a handle or grasping portion 40. The baffle 38 is positioned between the sides 34 and positioned above the flat member 36. On the lower part of the members 30 there is a housing having depending legs 42, a front portion 44, a rear portion 46, and a bottom 48. This housing extends from the outer part of the member 30, underneath the exposed portion of the screen 32 and to the other member 30. It acts as a basin or a trap for ore and liquid which is passed through the exposed portion of the screen 32. In the rear wall 46 there is an opening 50. In the opening 50 there is positioned a pipe 52 having an inlet 54 near the front wall 44. The pipe 52 runs rearwardly from the inlet 54 and approximately near the middle of the concentrator 10 the pipe 52 bends upwardly into a short pipe 56. The pipe 52 is approximately on the longitudinal centerline of the concentrator 10 and is in between the downwardly depending spaced apart legs 58 of channel member 59. These legs 58 run longitudinally along the inner part of the concentrator 10. A collar 60 surrounds the short tube or pipe 56 and is on the upper part of the flat member 12. This collar 60 positions the short member 56. Actually, the collar 60 may be considered to be internally tapped and the outer portion of the pipe 56 may be threaded so that the collar 60 is screwed onto the pipe 56 so as to press the lower surface of the flat member 12 against the upper part of the pipe 50.

Positioned above the outlet 62 of the tube 56 is the rotating part of the ore concentrator 10. This rotating part comprises two tubes, 64 and 66. These two tubes join and the angle between these two tubes may be considered to be in the range

of approximately 56° to 60°. From experience, I have found a desirable angle to be about 58°. At the lower part of the two tubes 64 and 66 there is an opening 68. This opening surrounds the top of the tube 56 and may be approximately an eighth of an inch to three-eighths of an inch below the top of the tube 56 so as to just circumscribe the upper part of the tube 56. The top of the tube 64 is sealed at 70 and the top of the tube 66 is sealed at 72. In the tube 64, and on that portion away from the tube 66, there is an opening 74. Also, in the tube 66, and on that face away from the tube 64 there is an opening 76. The openings 74 and 76 are on the trailing faces of the tubes 64 and 66 so that liquid and solids flow out of the openings 74 and 76 as the two tubes 64 and 66 rotate.

From experience we have found that the clearance between the inner edge of the tubes 64 and 66 of the openings 68 and the outer surface of the tube 56 should be in the range of approximately one-sixteenth of an inch to three-sixteenths of an inch.

The tubes 64 and 66 are partially in a pan 78. This pan comprises circular sides 80 having an upper lip 82. The lower part of the sides 80 curve inwardly at 84 and form a flat portion 86. The flat portion 86 curves downwardly and inwardly to form member 88. The member 88 is in the configuration of a frustum of a cone and terminates at approximately the same place as the lower part of the two tubes 64 and 66 or near the opening 68 of these two tubes 64 and 66.

In the lower part of the pan 78 there is a circular member having a curved cuplike portion 90. The inner part of this cuplike portion 90 depends downwardly at 92 and then inwardly at 94. The flat portion 94 contacts the legs 64 and 66 so as to seal the opening between the member 88 and the legs 64 and 66 on the bottom of the pan 78. Further, the central portion of the pan 78 is flat and has an opening at 96. A center boss 98 is positioned above the center of the pan 78 and has a passageway 100 which is aligned with the passageway 96. The center boss 98 has a circular base 102 which has an opening 104 to receive the upper part of the leg 64 and has an opening 106 to receive the upper part of the leg 66. In the passageway 100 and the opening 96 there is positioned a shaft 108.

In the upper part of the pan 78 and inside of the pan and below the curved upper lip 82 there is positioned a rubber ring or a plastic ring 110. This ring 110 functions as a barrier to prevent the flow of solids out of the pan 78.

It is seen that the pan 78, the tubes 64, 66, and the shaft 98 are united into a unitary or integral structure. With the rotation of the shaft 108 the pan 78 and the tubes 64 and 66 rotate. As there is a clearance between the lower ends of the tubes 64 and 66 and the tube 56 it is seen that with the rotation of 78, 64 and 66 that there is no rotation of the tube 56.

On the upper part of the lateral braces 24 there is positioned a housing 120. This housing 120 has a hollow interior 122. The housing may be attached to the cross braces 24 by welding or riveting or any suitable mechanical means. As is seen, the front part of the housing 120 is positioned above the shaft 108. In fact, in the housing 120 there is a bearing 124 and a bearing 126. The upper part of the shaft 108 is in the housing 120 and is journaled in the two bearings 124 and 126. On the shaft 108, and between the bearings 124 and 126, there is positioned a sprocket 128. On the rear part of the housing 120 there is positioned a motor 130. The motor 130 has a depending output shaft 132. On the output shaft 132 there is a sprocket 134. A chain 136 runs between the sprocket 134 and the sprocket 128 so that the output shaft 132 drives the shaft 108. On the upper part of the housing 120 there is attached a stand 138. The stand 138 may be attached to the housing 120 by means of rivets or bolts and the like. Attached to the stand 138 is a handle 140 for ease of carrying the ore concentrator 10.

Around the upper portion of the pan 78 and the lower portion of the shaft 108 there is a case or housing having an upper flat member 142, a lower flat member 144, a front wall 146, and sidewalls 148. It is seen that there is no rear wall or that there is an opening 150. In fact, from FIGS. 3 and 4 it is seen

that the housing is composed of an upper portion and a lower portion which may be joined at the lip 152. The members 144, 142, 146, 148 may be composed of plastic such as polystyrene or reinforced fiber glass. On the inside of the walls 148 and 146 there is attached a protective band of high impact resistance polystyrene 154. In FIG. 4 it is seen that this band extends from below the upper part of the pan 78 and also above the upper part of the pan 78. This high impact resistance polystyrene band reduces abrasion on the walls 148 and 146. As can be readily visualized, ore and solids are thrown out of the pan and strike the band 154. If this band were not present, the walls 148 and 146 would be abraded and in time holes would be worn in these walls. From experience we have found that the band 154 prevents abrasion of the walls 146 and 148 and itself is abraded only to a very small degree. After considerable usage the band 154 showed substantially no abrasion.

In the cylindrical tubes 18 and 20 there is positioned an inflatable bag 156. The bag 156 may be of a long tubular construction and can be inflated at the site of usage. The reason for this is that the ore concentrator floats on water. In use, I have placed the ore concentrator in a stream or partially on the bank of a stream and partially in water. Then, I have shoveled sand and dirt and the like from the stream bed onto the platelike member 36 so that it runs down onto the screen 32. When the ore concentrator 10 is not being used then the floats 156 may be deflated and the ore concentrator carried to the next site of usage or stored.

In FIGS. 5 and 6 there is illustrated another version of the rotating part of the concentrator. This version 160 comprises a pan having circular sides 162 and an upwardly and inwardly curving lip 164. Also, the sides 162 curve downwardly and inwardly at 166 and into the bottom 168 of the pan. In the pan 168 there project two tubes 170 and 172. Tube 170 projects through an opening 174 and the tube 172 projects through an opening 176. In fact, these two tubes may be welded into position in the bottom 168. The upper part of the tube 170 is enclosed in 178 and the upper part of the tube 162 is enclosed in 180.

The lower part of the tubes 170 and 172 meet in a tubular member 182. As is seen in FIG. 5 the upper part of the tubes 170 and 172 unite while the lower part of these tubes form an opening and depend into a tubular member 182. Inside of the leg 170 there is another leg 186 and inside of the leg 172 there is a leg 188. The outer surface of the leg 186 is spaced approximately an eighth of an inch from the inner surface of the leg 170 and the outer surface of the leg 188 is spaced approximately an eighth of an inch from the inner surface of the leg 172. The leg 186 is approximately half the length of the leg 170 and the leg 188 is approximately half the length of the leg 172. The legs 186 and 188 join at their inner upper portion and depend downwardly to form an opening. The lower end of the legs 186 and 188 form a tubular member 190. The tubular member 190 extends below the lower end of the tubular member 182. In approximately the middle of the tubular member 190 there is a circular crossmember 192 having an opening 194 therein. The member 192 with opening 194 is the equivalent of an orifice. The tubes 186 and 188 are open at the top and are spaced inside the tubes 170 and 172 by means of spacers 196.

The lower end of the tube 190 surrounds the top of the tube 56. In fact, the distance between the inner surface of the tube 190 and the outer surface of the tube 56 should be in the range of approximately one-sixteenth of an inch to three-sixteenths of an inch or a clearance of that distance. The lower part of the tube 182 need not surround the upper part of the tube 56.

The angle between the two tubes 170 and 172, and the angle between the two tubes 186 and 188 may be in the range of approximately 56° to 60°. From experience, I have found that an angle of 58° is desirable.

In the upper part of the tube 170 and in the upper part of the tube 172 there are openings 200. These openings 200 are in the trailing portions of these tubes as these tubes rotate.

Under the lip 164 and inside of the pan 160 there is a ring, such as a rubber ring, 202.

The shaft 108 extends through the bottom of the pan 168 and is threaded on its outer end. A nut 204 bears against the bottom 168 of the pan so as to position it firmly on the shaft 108.

In FIG. 6 there is illustrated a plan view of the pan 160 of FIG. 5. In this FIG. it is seen that the openings 200 are on the trailing portion of the tubes 170 and 172 so that the liquids and solids are ejected from the tubes as the tubes whirl around. From experience I have found that the outlets 200 and also the outlets 74 and 76 may be at an angle of approximately 45° with respect to the diameter of the pans through the tubes 70, 72, or 170 and 172 so that these solids and liquids whirl outwardly from the trailing surface of the tubes.

In using the ore concentrator 10, as previously explained, I place the concentrator 10 in the stream bed or in water or on an ocean beach so that the lower part of the tubes 72 and 70 or the tubes 170 and 172 are below the water line. Preferably, I find it desirable that the water line be as indicated in FIGS. 1, 3, 4, and 5. In other words, the water line is almost up to the bottom of the pan 78 or the pan 160. Then, I start gasoline motor 130 so as to rotate the pan 78 or the pan 160. Then, I shovel sand or gravel or dirt or whatever is convenient in this line onto the plate member 36. Sand and gravel will slowly run down and onto an open portion of the screen 32. As the open portion of the screen 32 is below the water level the fine portions which can pass through the screen do so. In the small model which I have used the openings in the screen are approximately a quarter of an inch and allow objects smaller than a quarter of an inch to pass through the screen and into the housing member indicated by reference numerals 42, 44, 46 and 48.

With the rotation of the pan 78 or the pan 160 there rises water or liquid into the tubes 70 and 72, or 170 and 172. Actually, the pressure is decreased so that water rises into these tubes. The apparatus is self-priming as at first the water rises between the opening of the lower part of the tubes 70 and 72 and the tube 56 or between the tubular member 190 and the tube 56. Then, there is a decrease in pressure above the tube 56 and the liquid is forced through the tube 52 and the tube 56 into the lower part of the tubes 70 and 72 or 170 and 172. Some people consider that the liquid is sucked through the tubes 52 and 56 into the lower part of the tubes 70 and 72 or 170 and 172. In the drawing it is seen that the end of the tube 52 terminates underneath the screen 32 so with the flow of liquids there is also a flow of fine solids into the opening 54, into the tube 52 and through the tube 56 into the lower part of the tubes 70 and 72. The liquids and solids flow up through the tubes 70 and 72 or 170 and 172 and out the openings 74 and 76 through the openings 200. The liquids and solids, due to centrifugal force, flow outwardly against the sides of the pans 78 and 160. The solids tend to separate from the liquids and settle toward the bottom of the pan 78 or 160 and the liquids flow over the rings 110 or 202. Actually, pans 160 and 78 tend to collect solids. However, we have found from experience that the lighter solids are displaced out of the pan and flow around the rings 110 and 202 and over the lips of the pans. The heavier solids tend to concentrate inside of the pans 78 and 160. Actually, with the ore concentrator 10 we have just described having openings of one-fourth inch in the screen 32 we have found pieces of gold ranging in the size from slightly smaller than one-fourth of an inch down to colloidal gold. Further, we have found silver ranging from sizes slightly smaller than one-fourth of an inch down to colloidal silver. At another time this apparatus was used in a stream bed. The party using the apparatus saw traces of rock which were interesting to him. He continued to go up the stream sampling the stream bed as he went up the stream. Finally, he ran across a bed of this rock and secured the rights to the rock. The rock is composed of quartz, with traces of nickel and copper. It has rather interesting coloring and this person is now mining and selling this rock for decorative fireplaces, siding, planters, and the like.

A particular model we have made weighs approximately pounds complete. This includes the motor, the pan, the frame, and the screen. In this particular version the pan 78 is of 9 diameter and the spacing between the outlet openings 74 and 76 is 6 inches. The tubes 70 and 72 are 1½ inches in diameter and the openings 74 and 76 are five-eighths inches in diameter. The clearance between the lower part of the tubes 70 and 72 and the upper part of the tube 56 is one-eighth of an inch. The tube 56 is of a diameter of 1¼ inches. The speed of rotation of the pan 9 1,750 r.p.m.

Likewise, the pan 160 is 9 inches in diameter and the distance between the openings 200 is 6 inches. The tubes 170 and 172 are 1½ inches in diameter and the openings 200 are five-eighths inches in diameter. The clearance between the bottom of the tube 190 and the tube 56 is one-eighth of an inch. The tube 56 is 1¼ inches in diameter.

A larger version of this ore concentrator may have a pan 78 or 160 at 24 inches in diameter with the tubes 70 and 72 or the tubes 170 and 172 being 4½ inches in diameter. The openings 74 and 76 or the openings 200 may be 3 inches in diameter. The clearance between the bottom of the tubes 70 and 72 and the top of the tube 56 or the tube 190 and the tube 56 may be one-eighth of an inch. The tube 56 may have a diameter of approximately 4¼ inches. The speed of rotation of the 24 inch diameter pan is approximately 644 r.p.m. It requires approximately a 5 horsepower engine to drive this pan.

Although I have described my invention with reference to a screen having openings to pass material of less than one-fourth inch in diameter, it is to be realized that larger openings may be used.

This invention has been described with respect to a small ore separator weighing approximately 22 pounds and driven by a three-quarter horsepower gasoline engine. The screen 32 has been of such a size as to allow a particle of ore having a diameter less than one-fourth inch or rocks the dimension of one-fourth inch to pass through the screen. It is to be realized that with larger models of the ore separator 10 that the openings in the screen 32 may allow material of one-half inch, or 1 inch or even 2 inches to pass through the screen. In the main, the heavy elements, such as gold and silver and the rare earth will be found in small sizes and the need for a screen having an opening to allow 1 inch diameter particles through will be limited. Most of the gold will be found in small nugget sizes, small particle sizes, and even down to the size of colloidal gold.

From the foregoing it is seen that the pan 78 and the pan 160 with associated equipment are to a degree a pump for pumping a liquid and small solids. Actually, the 22 pound ore concentrator 10 pumps a large quantity of both liquids and solids into the pans 160 and 78. The pan 78 and the pan 160 with associated equipment can be used as a self-priming pump for liquids such as water. Also, the tube 52 can be vented to the atmosphere and used as a vacuum pump.

After the liquid and the solids, having a low specific density, viz, a specific density less than about 8, have been separated from the heavy residual solids, the motor 130 may be stopped. Then the ring 110 or 202 may be removed and the heavy residual solids containing matter such as gold, silver, platinum and the rare earths, may be removed from the pan.

In FIG. 8 there is illustrated another version of the rotating part of the concentrator and which version is similar to that of FIG. 6. However, the difference between FIG. 8 and FIG. 6 is that in FIG. 8 there are four tubes and four outlets and in FIG. 6 there are two tubes and two outlets. FIG. 5 may be considered to be a vertical, lateral cross-sectional view of both FIGS. 8 and 6, as indicated on FIG. 8. Where there are like components for FIGS. 8 and 6, like reference numerals will be used. In FIG. 8 there is a version 208 and which version comprises a pan having circular sides 162 and upwardly and inwardly curving lip 164. Also, the sides 162 curve downwardly and inwardly at 166 and into the bottom 168 of the pan. In the pan 168 there project four tubes, 210, 214, 218, and 222. Tube 210 projects through an opening 230; tube 214 projects through an opening 228; tube 218 projects through an open-

ing 226; and, tube 222 projects through an opening 232; in the bottom of the pan 168. In fact, these four tubes may be welded into position in the bottom 168. The upper part of the tube 210 is enclosed in 212; the upper part of the tube 214 is enclosed in 216; the upper part of the tube 218 is enclosed in 220; and, the upper part of the tube 222 is enclosed in 224. The tubes 210, 214, 218, and 222 have an opening 200 on the trailing edge and which opening allows the egress of liquid and solid.

In FIGS. 9 through 14 there is illustrated another ore concentrator 250. This ore concentrator comprises a rotor 252 and which rotor comprises a housing 254, a pan 256 and a divider 258. The rotor may be of integral construction with the housing and pan of a unitary construction. The housing 254 is of the general configuration of a frustum of a cone and has a wall 260 which curves inwardly at its outer end into an end wall 262. In the end wall 262 there is an opening 264. The inner part of the wall 260 for the housing 254 curves outwardly into a bottom wall 266 of the pan 256. The bottom wall 266 curves upwardly into the sidewall 268 of the pan. It is seen that on the outer part of the sidewall 268 there is attached a cap or cover 270. The cap or cover 270 has an opening 272. The cap or cover 270 covers part of the pan 256.

In the bottom wall 266 there is at least one opening and, preferably, a plurality of openings 274. It is seen that these openings 274 are near the inner part of the bottom wall 266. The divider 258 comprises a flat portion 276 and has a hollow stem 278. In the flat portion 276 there is at least one opening 280 and, preferably, a plurality of openings 280. We have used four openings 280 in a flat portion 276.

The hollow stem or hub 278 is attached to a spider or reinforcing member 282. The outer ends of the member 282 are fixedly positioned with the wall 260 of the housing 254. In FIG. 11 there is illustrated the spider or reinforcing member 282 and its four legs are vanes 284. These legs or vanes are definitely positioned with respect to the inner surface of the wall 260.

The outer end of the hollow stem 278 is rigidly positioned with respect to the vanes 284. As is seen in FIG. 9, the peripheral portion of the surface of the divider 258 is attached to and definitely positioned with respect to the bottom wall 266. In effect, the divider 258, the spider 282, and the wall 260 are definitely positioned with respect to each other and assist in reinforcing each other by so being definitely positioned. The hollow stem 278 houses a shaft 290. On the shaft 290 there is positioned a baffle plate 292 and which baffle plate has an opening or passageway 294. The baffle plate 292 is definitely positioned on the shaft 290 and is definitely positioned with respect to the divider 258.

In FIG. 9 it is seen that the divider 258 does not cover the openings 274 in the bottom wall 266. Further, in FIG. 9 it is seen that the baffle plate 292 is of a larger diameter than the divider 258 and overlies the divider 258, and even overlies the openings 274 in the bottom wall 266. The baffle plate 292 may be spaced apart from the divider 258 by the length of the hub 296 on the baffle plate 292.

The shaft 290 may be rotated by means of a motor 130 as previously explained with respect to the ore concentrator 10 as illustrated in FIG. 1. There are numerous suitable commercially available motors for rotating the shaft 290. It is conceivable that in certain places that an electric motor may be employed as well as a gasoline motor or a kerosene motor.

There surrounds the upper part of the pan 256, or the upper part of rotor 252, a case or housing 300. The case or housing comprises sidewall 302 and flat wall 304. In the flat wall 304 there may be an inwardly corrected lip 306 which surrounds an opening 308. The wall 302 does not extend completely around the upper part of rotor 252 but terminates so as to provide an opening 310. In FIG. 9 it is seen that the case or housing 300 may be of a two piece construction with identical upper and lower halves and which halves are reversed and bonded together to form the housing. In this way, the opening 308 in the lower part surrounds the pan 256.

In FIG. 9 it is seen that there is a sloping collection chute 320. The collection chute has a sidewall 322 and a bottom wall or surface 324. In the bottom wall or surface 324 there is inwardly directed lip 326 surrounding an opening 328. The opening 328 encircles the wall 260 of the housing 254. Further, the sidewalls 322 bend outwardly into a flange 330. The flange 330 is positively attached to the lower wall 304 of the case or housing 300.

In FIG. 9 it is seen that the bottom wall 324 of the collection chute 320 slopes downwardly and terminates above a collection box 334. The collection box is housed and positioned in a retainer 336. There is a fastening means 338 for positioning the collection box 334 in the retainer 336.

In FIG. 10 is an elevational view looking at the collection box as positioned underneath the lower outlet end of the chute 320. From FIGS. 9 and 10 it is seen that any liquid and solid falling from the collection chute will flow into the collection box 334. This provides a convenient way and means to collect the concentrated ore. In FIG. 11 there is illustrated a guide rib 342 on the lower surface 324 of the collection chute 320 for directing the liquid and concentrated ore into the central portion of the collection box 334.

Further, in FIG. 11 there is illustrated the four vanes 284 of the spider 282 and also the hollow stem 278 and the shaft 290.

In FIG. 12 there is illustrated the divider 258 and the three openings 274. The three openings 274 are in the configuration of an arc and cover approximately a 60° arc. Also, there is illustrated the four openings or holes 230 in the divider 258. The four vanes 284 of the spider 282 are illustrated in phantom.

In FIG. 13 there is illustrated a view looking down on the baffle plate 292. Further, there is illustrated the four openings in the divider 258 and the three openings or slots 274 in the bottom wall 266 of the pan 256.

FIGS. 9 through 13 pictorially illustrate the arrangement of the housing 254, the divider 258, and the pan 256, and the rotor 252; the baffle plate 292, the collection chute 320 and the collection box 334.

A pipe 350 projects through the opening 264 and into the outer part or lower end of the housing 254. This pipe 350 terminates so as not to interfere with the divider 282. The clearance between the pipe 350 and the end wall 260 surrounding the opening 264 ranges from approximately one-sixteenth of an inch to three-sixteenths of an inch. As is seen in FIG. 9, the pipe 350 bends at a right angle into pipe 352. The pipe 352 is an inlet pipe and terminates adjacent to a screen 354, see FIG. 14. There is a frame for supporting the rotor, pipes, motor, and the like. In FIG. 14 it is seen that there are two longitudinal circular tubes 356. In these tubes there are provided two buoyant floats or means 358. The floats 358 may be a solid foamed plastic in an envelope or container, such as in a plastic skinlike polyethylene, polyvinyl chloride, polyvinyl alcohol, and the like. The floats 358 must have a relatively low specific gravity so as to be able to have sufficient buoyancy for partially floating the ore concentrator 250. A crossmember 360 may run between two of the cylindrical tubes 356 and may be attached to a cylindrical tube 356 by straps 362.

Likewise, in the front there may be a crossmember 364 which is attached to the cylindrical tube by means of a strap 366. The screen 354 may be positioned below a platform of sloping plate 370 similar to the ore concentrator as illustrated in FIG. 3.

The pipe 352 may be positioned by means of cross braces 372 and 374 and which cross braces connect with the cylindrical tubes 356.

The housing or case 300 may be positioned by means of straps 380 which connect with the cylindrical members 356.

The size of the screen openings in the screen 354 may be one-fourth of an inch. Actually, the size of the screen openings may be any reasonable size from one-half an inch to smaller, for a small unit. The size of the screen openings in the screen 354 are determined by the size of the holes 280 and clearance between the baffle plate 292 and the divider 258. In a small

machine the size of the screen openings may be one-fourth inch and be satisfactory.

In operation the ore concentrator 250 may be placed in a stream bed and a person may shovel sand and gravel and the primary material in a stream bed onto the screen 354. With the rotation of the rotor 252 there is created a differential pressure between the housing 254 and the atmosphere with the pressure in the housing 254 less than the pressure at the inlet end of the pipe 352 near the screen 354. The liquids and solids pass through the pipe and into the housing 254. Then, the solids and liquids pass through the openings or holes 280 and the baffle plate 292 directs the solids and liquids downwardly but due to centrifugal forces, the solids and liquids are flung outward toward the sidewall 268 of the pan 256. As is well known, the heavier material due to centrifugal action are closer to the sidewall 268 of the pan 256 while the lighter materials are more toward the center of the pan 256. The lighter materials and most of the liquid flow out of the pan 256 and over the cap or cover 270 and hit against the walls of the case or housing 300. Then, these lighter solids and liquids flow out the opening 310 and back into the stream bed. Now, the heavier material, such as gold, silver, and the rare earths, collect along the sidewalls 268 but the liquid, such as water, is continually washing these heavier materials. When an operator considers that he has sufficient heavier materials near the sidewalls 268, then the operator may stop the machine and the liquid present in the pan washes the heavier solids down toward the bottom of the pan and out through the slots 274. The heavier solids and liquids then flow down the collection chute 320 and into the collection box 334. When the rotor 252 is at rest the liquids and solids along the sidewall 268 will flow down the sidewall and through the openings 274.

From FIGS. 9, 11, and 12 it is seen that the vanes 284 are integral with the divider 258 and extend in the housing to a slight distance above the outlet of the pipe 350. There are four vanes and therefore four compartments 285. With the divider 258 submerged to the waterline and the rotation of rotor 252 these four compartments 285 also rotate and induce priming and the prime continues as long as the opening 264 remains below the waterline. The mixture of solid and liquid flows into each of the compartments 285 and from the compartments through the holes 280 into the pan 256 causing flow through the pipe 350.

This ore concentrator 300 weighs approximately 19 pounds. The pan 256 is approximately 9 inches in diameter. The speed of rotation of the rotor 252 is approximately 1,350 r.p.m.

In FIGS. 15, 16, and 17 there is illustrated a modification of the ore concentrator and which modification is capable of separating a liquid from a solid, such as water from suspended matter in the water. This modification is termed water purifier 400 and which water purifier comprises a rotor 402. The rotor 402 comprises a housing 404, a divider 406, and a pan 408. In a lateral cross-sectional view, the housing 404 and the pan 408 are generally circular in configuration.

As is seen in FIG. 15, the housing 404 is in the configuration of a frustum of a cone with the opening 410 in the bottom. The opening 410 is in the small part of the housing 404.

The upper part of the housing meets with the bottom 412 of the pan 408. Then, the bottom 412 of the pan curves upwardly into a sidewall 414 of the pan.

Approximately at the junction of the housing 404 and the pan 408 there is a divider 406. The divider 406 comprises a circular disc having four holes 416. The divider 406 has a hollow stem or hub 418. There is attached to the hub 418 four spaced apart vanes 420. In FIG. 16 it is seen that the vanes 420 in conjunction with the housing 404 define four compartments 422.

It is seen that in the pan 408 there are a number of holes 424. These holes are near the outer part of the bottom 412 and at the junction of the bottom 412 and the sidewall 414 of the pan.

There is positioned in the pan a rotating baffle plate 426. The baffle plate 426 has a hub 428. The diameter of the rotat-

ing baffle plate 426 is greater than the diameter of the divider 406.

There is positioned above the rotating baffle plate 426 an interiorly directed baffle 430. The baffle 430 is integral with the sidewall 414 of the pan 408 and has an interior opening 432.

There is positioned above the baffle 430 another baffle 436, which is integral with sidewall 414. The baffle 436 has an opening 438. The central opening 438 is of less diameter than the opening 432 in the baffle 430. Therefore, the baffle 436 tends to baffle more of the material in the central part of the pan 408 than does the baffle 430. Further, the baffle 436 at the periphery has a number of holes or openings 440.

There is positioned above the baffle 436 another baffle 442. The baffle 442 has a central opening 444. The central opening 444 is of greater diameter than the central opening 438 in the baffle 436. The baffle 442 is integral with the sidewall 414 of the pan 408 and is directed inwardly as illustrated in FIG. 15.

On the upper part of the baffle 442 and integral with the baffle 442 and sidewall 414 of the pan are a number of dividers 450. With the rotation of the pan 408 and the liquid flowing over the baffle 442 and onto the upper part of the baffle 442, the dividers 450 direct the liquid outwardly.

In FIGS. 15 and 17 it is seen that there is a cap or cover 452. The cap or cover 452 has an upper circular part 454 and depending sidewall 456. In the circular part 452 is an opening 458. Further, in the sidewall 456 there is an opening 460. The sidewall 456, around the opening 460, is extended into walls 462 which define a nozzle or a chute 464. The liquid flows through the nozzle 464 and away from the cap 452. On the lower part of the sidewall 456, and inwardly thereof, is a gasket or ring 468.

For the rotor 402 in the fixed cap or cover 452 there is supporting structure. For example, the supporting structure may comprise two spaced apart ellipsoidal housings 470. In each of the housings 470 is a buoyant float 472. To the upper part of the housing 470 there is attached a platform 474. As is seen, the platform 474 on each end has lugs 476 which are curved to conform to the curve of the housing 470. The platform 474 is attached to the cap or cover 452 by means of lugs 478 and rivets as illustrated in FIG. 15. In the platform 474 there is a passageway 480. In the passageway 480 there is positioned a shaft 482. The shaft 482 leads to a motor which is used to rotate the rotor 402.

Also, in FIG. 15 it is seen that the lower part of the housing 470 connects with a lower platform 490 by means of legs 492. The lower platform 490 has four outwardly and spaced apart directed fins 494. The fins 494 are shaped to cofit with the housing 404. Further, these fins 494 may be at 90° angles with each other. There is a screen 496 which surrounds the opening 410 in the housing 404 and surrounds the fins 494. The screen 496 screens out the large solid particles so that the liquid purifier 400 has to separate only the small solid particles from the mixture of solid particles and liquid.

Further, it is seen that the water purifier 400 is designed to float on the water and with the divider 406 submerged to the waterline then the rotation of the rotor 402 causes priming. It is to be remembered that this waste contains solid material which must be separated. The mixture of water and solid material flows through the hole 416. The rotating baffle plate 426 directs the mixture of water and solids downwardly so that the mixture flows toward the outer part of the pan 408. Most of the solid and some liquid exit from the pan 408 through the hole 424. Then, the rest of the mixture of solid and liquid flows upwardly along the inner surface of the wide wall 414. The solid, being heavier than the water, stays close to the inner surface of the sidewall 414, due to the centrifugal action, and only a small percentage of this solid flows around the baffle 430. The liquid, in time, does flow around the baffle 430 and through the opening 432. Then, the liquid flows through the openings or holes 440 in the baffle 436. Further, with the upward flow of the mixture of liquid and solid, the solid once again stays close to the inner surface of the sidewall 414. The

baffle 442 hinders the flow of solid upwardly while the liquid, in time, will flow upwardly. Upon the liquid flowing through the opening 444 and past the baffle 442, the liquid flows into the area above the baffle 442 and through the divider 450 and through the nozzle 464. On the outlet end of the nozzle 464 there may be a means for catching the liquid or there may be a further filtering means 490. The filter 490 may remove the very small solid particles which have managed to flow through the rotor 402. The filter 490 may be a commercially available filter used for eliminating or removing small particles of solid from a liquid. The filter 490 may connect with an outlet 492. The outlet 492 may lead to a reservoir for the purified liquid.

The speed of rotation of the rotor 402 will vary upon the conditions of the mixture of solid and liquid. For a mixture having large heavy solids the speed of rotation will be less than for a mixture of solid and liquid wherein the solids are small and have a relatively low specific weight. In essence, the speed of rotation of the rotor 402 will depend upon the type of mixture of solids and liquid and the proper speed will have to be determined for the mixture.

We claim:

1. An ore concentrator, said concentrator comprising:
 - a. a pan having a base, a side and an inwardly directed lip on the side;
 - b. there being at least two tubes;
 - c. each of said tubes being on both sides of the base of said pan and terminating inside of said pan;
 - d. the end of each tube in the pan being sealed;
 - e. each tube having a first opening inside of the pan;
 - f. said tubes being at an angle with each other;
 - g. the outer end of each tube outside said pan joining together to form a unitary structure having a second opening;
 - h. a third tube and a fourth tube;
 - i. said third tube being in one of said tubes and the fourth tube being in the other one of said tubes;
 - j. said third and fourth tubes being at an angle with respect to each other;
 - k. the outer end of the third and fourth tubes joining together to form a unitary structure having a third opening;
 - l. a pipe leading into said third opening;
 - m. there being a clearance between said third opening and the pipe; and
 - n. a means to rotate the pan and the tubes.

2. A purifier for separating a liquid from a solid, said purifier comprising:

- a. a rotor having a housing, a pan and a divider;
- b. said housing and said pan connecting with each other;
- c. said divider separating said housing and said pan;
- d. there being a first means in said divider to allow communication between the housing and the pan;
- e. said pan having openings to allow solids and liquids to leave said pan;
- f. said housing having an open end for connecting with a source of a mixture of liquid and solid;
- g. a first baffle in said pan;
- h. said first baffle being positioned away from said divider and said housing;
- i. a third means to direct said liquid from said pan; and
- j. a fourth means to rotate said rotor including the housing, the pan and the divider.

3. A purifier according to claim 2 and comprising:

- a. a fifth means to divide said housing into a plurality of compartments;
- b. said compartments and said pan communicating by said first means; and
- c. said housing being in the configuration of a frustum of a cone with the small part of the cone having said open end.

4. A purifier according to claim 2 and comprising:

- a. said pan having a bottom wall which extends radially outwardly beyond the top edge of the housing;
- b. said pan having a passageway in that part of the bottom wall and said passageway juxtapositioned to the peripheral portion of said bottom wall; and
- c. said passageway allowing solid and liquid to leave the pan.

5. A purifier according to claim 4 and comprising:

- a. a rotating second baffle in said pan;
- b. said rotating second baffle being positioned adjacent but spaced apart from said divider; and
- c. said rotating second baffle overlies said first baffle for directing solid and liquid toward said bottom wall.

6. A purifier according to claim 4 and comprising:

- a. a plurality of said rotating second baffles in said pan.

7. A purifier according to claim 4 and comprising:

- a. a fifth means to float said purifier on a mixture of the liquid and solid; and
- b. said fifth means permitting the open end of said housing to be in said mixture of the liquid and solid.

50

55

60

65

70

75