

A. R. Field. Loom Shedding.

N^o 10,989.

Patented Apr. 19, 1870.

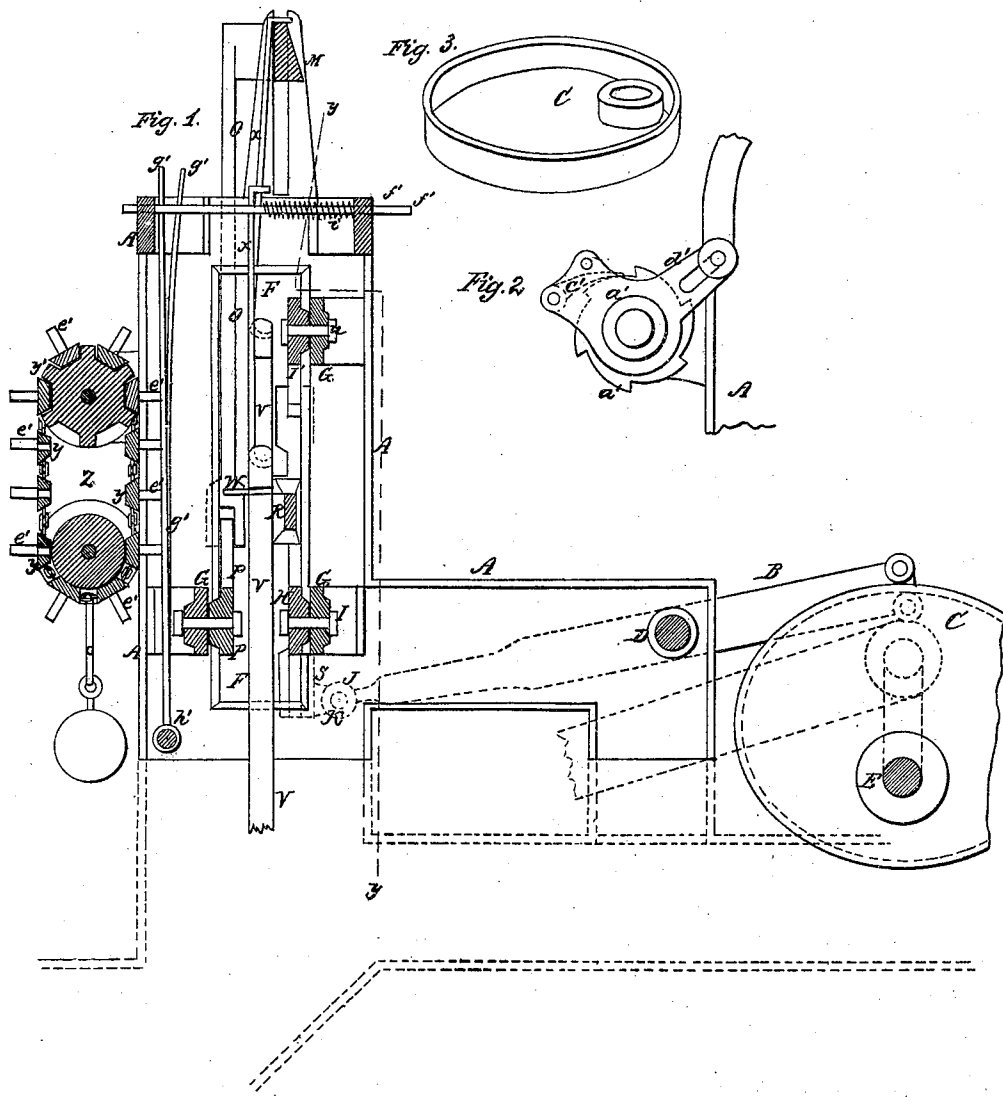

Witnesses:
Guerrero Dietrich
Egar Tate

Inventor:
A. R. Field
 per *Munn & Co*
 Attorneys

A. R. Field. Loom Shedding.

Sheet 2 - 2 Sheets.

N^o 101,989.

Patented Apr. 19, 1870.

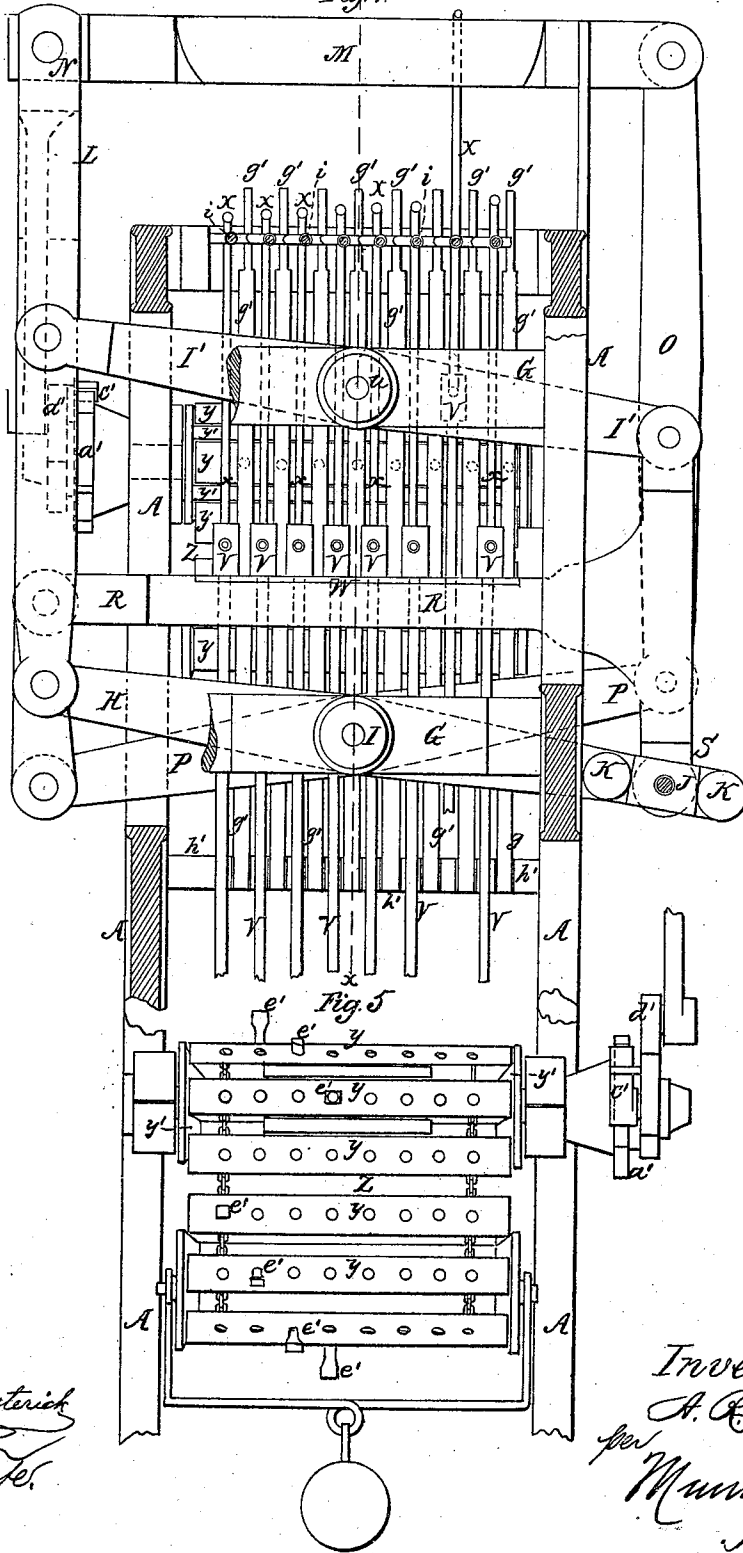

Witnesses.
Gustave Dietrich
Edgar Cole.

Inventor
A. R. Field
per
Munn & Co.
Attorneys.

United States Patent Office.

ALBERT R. FIELD, OF CENTRAL FALLS, RHODE ISLAND.

Letters Patent No. 101,989, dated April 19, 1870.

IMPROVEMENT IN LOOM

The Schedule referred to in these Letters Patent and making part of the same.

To all whom it may concern:

Be it known that I, ALBERT R. FIELD, of Central Falls, in the county of Providence and State of Rhode Island, have invented a new and useful Improvement in Looms for Fancy Weaving; and I do hereby declare that the following is a full, clear, and exact description thereof, which will enable others skilled in the art to make and use the same, reference being had to the accompanying drawings forming part of this specification.

This invention relates to new and important improvements in looms for weaving fancy goods; and

It consists, mainly, in the mechanism for raising and lowering the harness of the loom, but embraces, in combination with such mechanism, other and improved mechanical appliances for producing the necessary motion for properly operating the harness, changing their positions, and thereby changing the figure or face of the goods woven.

In the accompanying sheet of drawings—

Figure 1, Sheet I, represents a vertical section of fig. 4 on the line *x x*.

Figure 2 is a detailed view of the ratchet and pawl for revolving the "card."

Figure 3 is a detailed view of the cam, by means of which the proper motion is imparted for operating my improvement. This cam is placed on the crank-shaft of the loom, the shaft and parts of the loom-frame being shown in dotted lines on this sheet.

Figure 4, Sheet II, is a section of fig. 1 through the line *y y*.

Figure 5, Sheet II, is a back view of the "card," giving also an edge view of the ratchet and pawl by which it is revolved.

Similar letters of reference indicate corresponding parts.

This improvement is an attachment to looms employed for weaving fancy goods, the main object being to operate upon the harness used for varying the figure of such goods.

With this view, my improved apparatus is placed on top of the loom, so that each harness may be operated upon separately, and raised and lowered by the same mechanism alternately, or in any desired manner.

A represents a suitable frame-work, by which the operating parts of my improvement are supported.

A portion of this frame is horizontal, as seen in fig. 1, which portion supports the lever B, (seen partly in dotted lines,) which lever receives its motion from the cam C, and, by its vibration on its fulcrum D, imparts the requisite motion to raise and lower the harness and revolve the card.

E is the crank-shaft of the loom.

Friction rolls engage with each side of a flange

around the rim of the cam, by means of which a positive reciprocating motion is imparted to the lever.

A portion of the cam C is the arc of a circle whose center is the center of the loom-shaft E, which circle gives the harness the necessary period of rest.

As seen in fig. 1, the main portion of the frame consists of a double upright frame, from which the horizontal portion is extended.

F represents a broad open space in each side of the frame.

G represents transverse rails on each side of the open spaces F.

H is a vibrating bar, which is pivoted to one of the lower rails G, as seen at I.

The end of the vibrating lever B is connected with this bar H by means of the block J, which hangs on pivots in lugs K, projecting from the bar.

L is an upright piece which is pivoted to the other end of the bar, and

M is a horizontal lifting-rail, rigidly attached thereto, as seen at N.

O is an upright piece, which is attached to the other end of the lifting-bar M, and, consequently, rises and falls with it.

This upright piece O is jointed at its lower end to another vibrating bar P, which is pivoted to a transverse rail, G, on the other side of the open space F, on which pivot Q it is vibrated.

R is a horizontal frame, which is connected with the vibrating bar P at one end, and to the vibrating bar first named, (H,) as seen at S.

This frame R is also connected with the lifting-rail and upright piece L by means of the vibrating bar T, which is pivoted to the rail of the main frame, as seen at U.

It will thus be seen that all the parts which we have described as vibrating or moving vertically are connected together and move simultaneously, by virtue of the motion imparted by the cam and lever B.

V represents a series of lifting bars, which pass through orifices in a plate, W, on top of the frame R, the edge of the plate being seen in fig. 4. Each of these bars V is shouldered, and the shoulders rest on the plate W when the bars are down. Below the shoulder or shoulders they work freely in the orifices through the plate.

Each of these hanging bars is connected with a harness of the loom, by which the harness is raised and lowered, as we will now proceed to describe.

To each of the bars V is attached a lifting-rod *x*, the ends of which extend up, and are turned at right angles, so as to hook onto the top of the lifting-rail M, when in proper position. One of them, with the bar V, is seen in fig. 1 thus lifted. When this lifting operation is performed, the bars V are raised by the

rise of the frame R, which carries the plate W, and, at the same time, (by means of the vibrating bars and connections already described,) the lifting-rail M descends and receives the hook on the end of the lifting-rod.

When a rod is thus hooked onto the rail the motion of the frame R (with the balance of the bars) is reversed, and also that of the lifting-rail, which now ascends, carrying up the rod, and, consequently the harness, while the lifting-bars, with the harness connected therewith, descend to their lowest position.

To throw the lifting-rods x forward, so that they will catch onto the lifting-rail, is the duty of the card z , at the back of the machine, seen in fig. 5. This "card" is simply an endless apron, formed of cross-slats y , linked or jointed together, and revolved on a drum, y' , by means of a ratchet and pawl arrangement, seen detached in fig. 2.

The ratchet is marked a' , and is fast on the shaft of the drum.

C is the pawl, which is attached to a bell-crank, d' , which rocks on the end of the card drum-shaft.

The bell-crank d' is connected with the upright piece L of the lifting-rail, and receives motion therefrom to work the pawl and ratchet and revolve the card.

The motion imparted in this manner is, of course, an intermittent motion, but the periods of movement are regulated with especial reference to the movement of the harness. It will be seen that each of the strips y of the card is perforated for holding a projecting pin, e' , which pin may be changed to any part of the slat.

f' , (fig. 1,) represents horizontal rods, which are allowed a longitudinal sliding movement in the upper portion of the frame. These horizontal rods correspond in number with the lifting-rods x , and each one has an orifice or eye, through which the lifting-rods pass, by means of which the position of the lifting-rods are governed.

g' represents vertical flat springs, attached at their bottom ends to a cross-rail of the frame, as seen at h' , corresponding in number with the lifting-rods, and also passing up through eyes in the horizontal sliding

rods f' . The holes in the slats of the card are placed so as to correspond with the position of these vertical springs g' , so that a pin placed in any one of them will strike and force before it a spring. This action gives the horizontal rod a forward movement which carries forward one of the lifting-rods x , so that it hooks onto the lifting-rail M. This forward movement of the lifting-rod takes place after the lifting-rail has descended to receive it.

The back motion of the horizontal sliding rods f' is produced by a spiral spring, z' , on each.

It will be seen that by changing the pins in the card-slats, the movement of the harness of the loom may be varied in any desired manner, and the figure or face of the woven fabric varied accordingly. While one harness is operated upon by the lifting-rail, the rest of them move with a uniform motion, but the lifting-rods x vary in length, diminishing gradually from first to last, as seen in the drawings. This construction is for the purpose of graduating the lift of the shed according to the distance from the cloth-making point, as usual.

It will be seen that the harness is not only raised, but lowered by the machine, springs, levers, or any suitable arrangement being provided beneath for drawing the harness down and keeping it in proper position.

Having thus described my invention,

I claim as new and desire to secure by Letters Patent—

1. The vibrating bars P H I, uprights O L, and rigid transverse bars M R, all attached to the frame, and arranged and operated as set forth.

2. The combination of bar H, rails G, block J, pivoted upright L, horizontal lifting-rail M, vertically-reciprocating upright O, and vibrating bar P, frame R, and vibrating bar I, when said parts are relatively arranged to be operated by a vibrating lever, B, as set forth.

ALBERT R. FIELD.

Witnesses:

WILLIAM KEENAN,
HENRY E. WHIPPLE.