

(No Model.)

J. D. G. THOMPSON.
VENTILATING FAN.

3 Sheets—Sheet 1.

No. 525,928.

Patented Sept. 11, 1894.

FIG. 1.

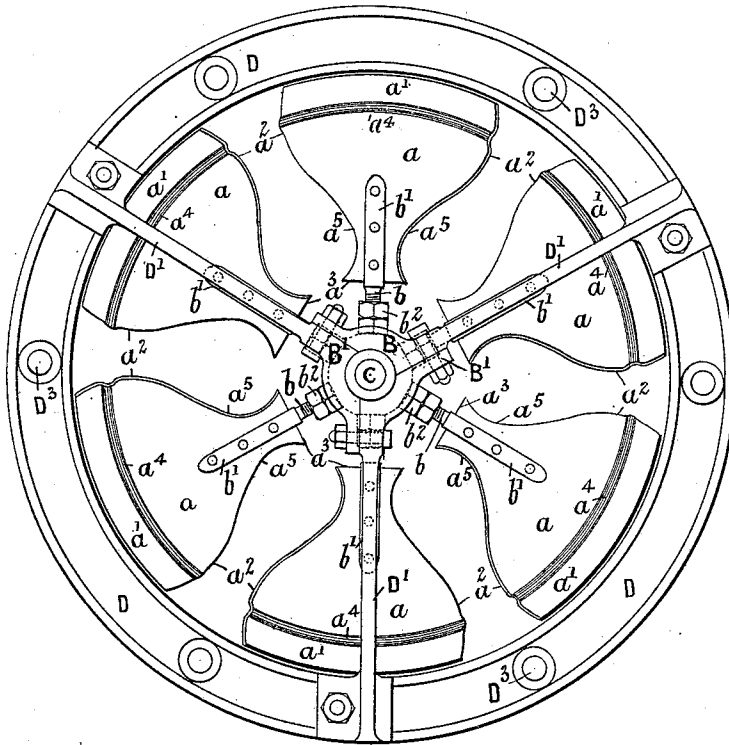
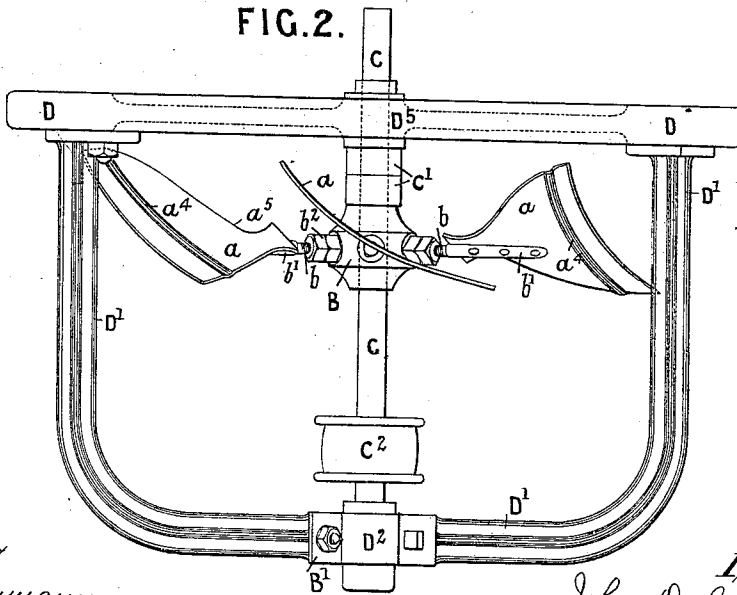

FIG. 2.



Witnesses
George Baumann

S. C. Connor

Inventor
John D. G. Thompson
By his Attorneys
Howson & Howson

(No Model.)

J. D. G. THOMPSON.
VENTILATING FAN.

3 Sheets—Sheet 2.

No. 525,928.

Patented Sept. 11, 1894.

FIG. 4.

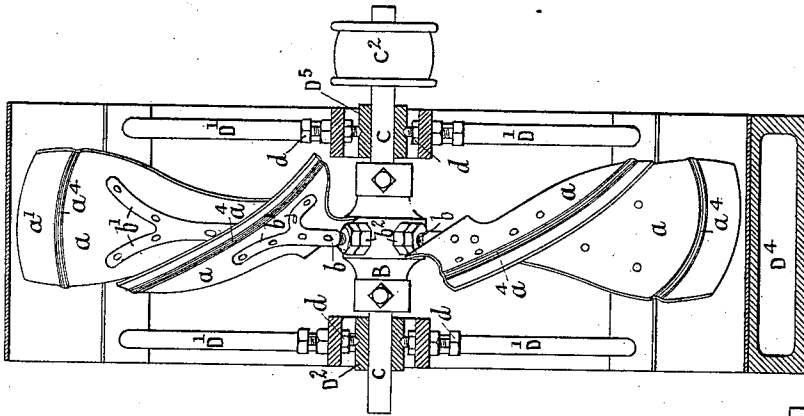
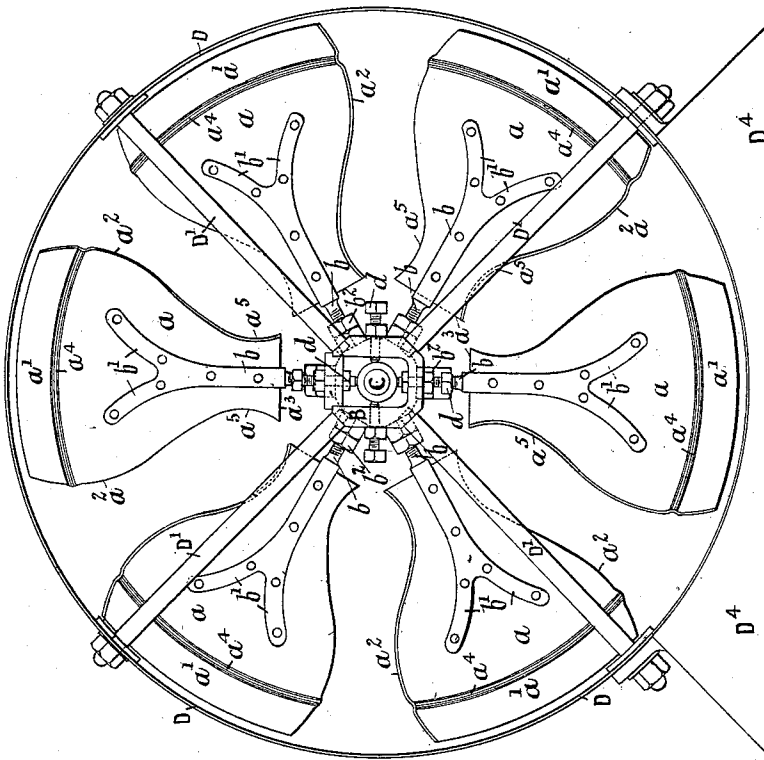

FIG. 3.



Witnesses:
George Baumann
S. C. Connor

Inventor
John D. G. Thompson
By his Attorneys
Hanson & Hanson

(No Model.)

J. D. G. THOMPSON.
VENTILATING FAN.

3 Sheets—Sheet 3.

No. 525,928.

Patented Sept. 11, 1894.

FIG. 9.

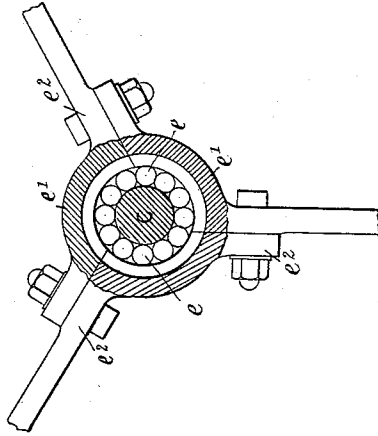

FIG. 5.

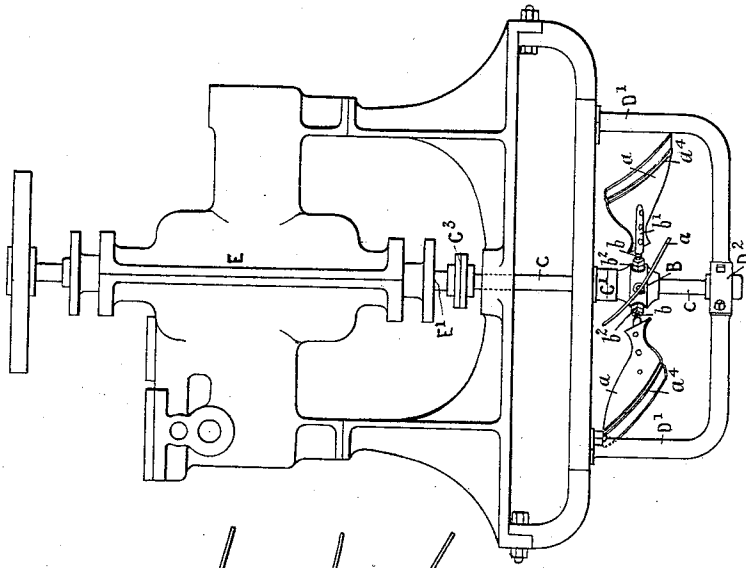
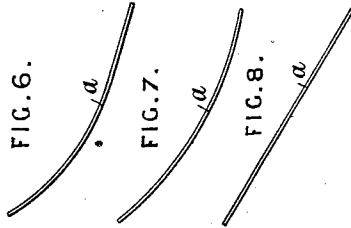

FIG. 6.

FIG. 7.

FIG. 8.



Witnesses
George Baumann
J. C. Connor

Inventor
John D. G. Thompson
By his Attorneys
Howson & Howson

UNITED STATES PATENT OFFICE.

JOHN D. GRAY THOMPSON, OF LONDON, ENGLAND.

VENTILATING-FAN.

SPECIFICATION forming part of Letters Patent No. 525,928, dated September 11, 1894.

Application filed January 23, 1894. Serial No. 497,784. (No model.) Patented in England January 14, 1893, No. 867.

To all whom it may concern:

Be it known that I, JOHN DUNCAN GRAY THOMPSON, ventilating and consulting engineer, a subject of the Queen of Great Britain and Ireland, residing at 159 Queen Victoria Street, London, England, have invented an Improved Ventilating-Fan, (for which I have obtained Letters Patent of Great Britain, No. 867, dated January 14, 1893,) of which the following is a specification.

This invention has reference to and comprises an improved rotary fan, for the ventilating of buildings, ships, and other structures in a more complete and efficient manner than hitherto.

The improvements essentially consist in an improved construction of the radial blades of a rotary fan, and in the combination of these blades with their carrying frames and adjustable fittings.

In order to enable others skilled in the art to which my invention relates to understand how it may be carried into effect, I have hereto appended three explanatory sheets of drawings, in which the same reference letters are used to indicate corresponding parts in all the figures where shown.

Figures 1 and 2 are an elevation and plan view respectively showing one arrangement of my improved fan as carried on a wall bracket frame. Figs. 3 and 4 are elevations at right angles to each other showing a slightly modified arrangement of my improved fan as carried on a base frame, while Fig. 5 is an elevation showing the fan as coupled to and driven direct by a steam engine. Figs. 6, 7, and 8 show edge views of three modified forms of the shape of fan blades. Fig. 9 is a sectional elevation showing how ball bearings may be used on the rotating axis of fan, and in which the frame may be formed of cast iron.

Referring to the drawings:—The fan would consist of a series of blades a attached by rivets to radial arms b adjustably secured to a central hub B mounted on a rotating shaft C carried in adjustable bearings, the whole being covered in by a protecting wire gauze frame.

By my improvements the fan blades a are formed of great breadth, wing form, from their outer extremity a' to past their center where

their convex edges a^2 gradually come in with a gentle curve on each side at a^5 and then approach outward to a straight base line at inner extremity a^3 . These blades would be embossed at a^4 and may curve inward transversely on one half their breadth as shown in Figs. 2 and 6, and gradually all the length as in Fig. 7, and they may assume a straight course as in Fig. 8 all so as to carry a maximum quantity of air in their rotating motion. The fan blades a would be riveted or attached to radial arms b , which would have their inner ends screwed into the hub B , on the rotating shaft C and tightened up by nuts b^2 so as to be capable of adjustment to any desired angle, and be reversed for use as an exhaust fan and as a pressure blower.

In the arrangement of fan, as shown in Figs. 1 and 2, the frame which incloses it consists of a cast iron rim D bolted to the wall through holes at D^3 , and three curved bracket arms D' bolted at B' to segmental malleable iron plates at the center; and the shaft C is carried in bearings at D^2, D^5 , tightening up collars C' being placed on shaft C between inner bearing D^2 , and the boss B of fan. The fan shaft C would be driven by a belt passed over a pulley C^2 , from any prime moving shaft. In the arrangement, shown in Figs. 3 and 4, the fan would be carried on a sole frame D^4 . The shaft C carrying the boss B , and fan blades a is carried in hollow octagonal bearings D^2, D^5 , on each side of the frame, and is adjusted by a series of pinching screws d . The outer rim frame D would be formed of sheet iron and a series of radial screw bars D' , would securely stay this to the central bearings D^2, D^5 and sole frame D^4 . The shaft C would be driven from the overhung pulley C^2 and in other respects this arrangement would be substantially the same as that shown in Figs. 1 and 2.

In the arrangement shown in Fig. 5, the fan shaft C is shown as connected by a clutch coupling C^3 , to the shaft E' , of an engine E . Fig. 9 is a sectional view illustrating how anti-friction ball bearings e may be applied to the boss of frame of the improved fan. In this case the fixed frame would preferably be formed of cast iron and the boss of same inclosing the chain or series of balls e would be formed in sectional parts e' and be bolted

together at e^2 and have the rotating shaft C in the center.

What I claim is—

- 5 1. A rotary fan having radial blades of wing form from their outer extremity a' to past their center, where their convex edges a^2 gradually curve in at a^5 and then approach out to a straight base line at inner extremity a^3 , substantially as described.
- 10 2. A rotary fan having radial blades of wing form from their outer extremity a' to past their center where their convex edges a^2 grad-

ually curve in at a^5 and then approach out to a straight base line at inner extremity a^3 , and embossed across their surface at a^4 substantially as described. 15

In testimony whereof I have signed my name to this specification in the presence of two subscribing witnesses.

J. D. GRAY THOMPSON.

Witnesses:

JOHN SIME,

R. C. THOMSON.