



(51) International Patent Classification:
E21D 21/00 (2006.01)

(21) International Application Number:
PCT/EP2018/083433

(22) International Filing Date:
04 December 2018 (04.12.2018)

(25) Filing Language: English

(26) Publication Language: English

(30) Priority Data:
18158246.1 22 February 2018 (22.02.2018) EP

(71) Applicant: SANDVIK MINING AND CONSTRUCTION OY [FI/FI]; PL 100, 33311 Tampere (FI).

(72) Inventors: ESKO, Mauri; Kolkontie 174, 39500 Ikaalinen (FI). MÄNTTÄRI, Maunu; Sandvik Mining and Construction Oy PL 100, 33311 Tampere (FI).

(74) Agent: SANDVIK ASSOCIATION; Sandvik Mining and Construction Oy PL 100, 33311 Tampere (FI).

(81) Designated States (unless otherwise indicated, for every kind of national protection available): AE, AG, AL, AM, AO, AT, AU, AZ, BA, BB, BG, BH, BN, BR, BW, BY, BZ, CA, CH, CL, CN, CO, CR, CU, CZ, DE, DJ, DK, DM, DO, DZ, EC, EE, EG, ES, FI, GB, GD, GE, GH, GM, GT, HN, HR, HU, ID, IL, IN, IR, IS, JO, JP, KE, KG, KH, KN, KP,

KR, KW, KZ, LA, LC, LK, LR, LS, LU, LY, MA, MD, ME, MG, MK, MN, MW, MX, MY, MZ, NA, NG, NI, NO, NZ, OM, PA, PE, PG, PH, PL, PT, QA, RO, RS, RU, RW, SA, SC, SD, SE, SG, SK, SL, SM, ST, SV, SY, TH, TJ, TM, TN, TR, TT, TZ, UA, UG, US, UZ, VC, VN, ZA, ZM, ZW.

(84) Designated States (unless otherwise indicated, for every kind of regional protection available): ARIPO (BW, GH, GM, KE, LR, LS, MW, MZ, NA, RW, SD, SL, ST, SZ, TZ, UG, ZM, ZW), Eurasian (AM, AZ, BY, KG, KZ, RU, TJ, TM), European (AL, AT, BE, BG, CH, CY, CZ, DE, DK, EE, ES, FI, FR, GB, GR, HR, HU, IE, IS, IT, LT, LU, LV, MC, MK, MT, NL, NO, PL, PT, RO, RS, SE, SI, SK, SM, TR), OAPI (BF, BJ, CF, CG, CI, CM, GA, GN, GQ, GW, KM, ML, MR, NE, SN, TD, TG).

Published:

— with international search report (Art. 21(3))

(54) Title: ROCK BOLT AND METHOD FOR DRILLING AND REINFORCING MATERIAL

(57) Abstract: A self-drilling rock bolt (1) is provided for drilling a drill hole (2) in a material to be drilled (3) and reinforcing the material surrounding the drill hole using a percussive or rotative rock drill. The rock bolt comprises an end anchor element comprising an anchor shell provided with anchor means for engaging with the material of the drill hole walls. The anchor means is arranged to protrude from the rock bolt body (5) at least when a force pulling the rock bolt backwards and away from the bottom of the drill hole is applied to the rock bolt.

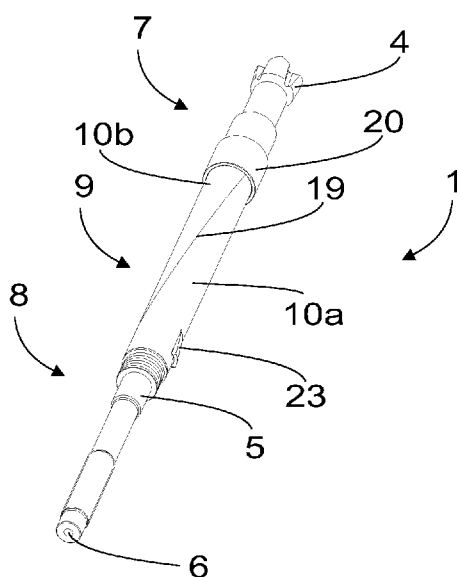

FIG. 1



ROCK BOLT AND METHOD FOR DRILLING AND REINFORCING MATERIAL

BACKGROUND

The present invention relates to a rock bolt and a method of drilling and reinforcing material surrounding a drill hole.

Different types of rock bolts are known. Typically, a drill hole is first drilled with a rock drill and then a rock bolt is inserted in the drill hole. In such solutions, more work phases are needed and the alignment has to be made separately for the rock drill and the rock bolt. Also some self-drilling rock bolts are known. However, in such solutions the rock bolt is typically anchored in the drill hole by resin or other chemical substance that takes time to harden, which slows down the drilling and enforcing process.

BRIEF DESCRIPTION

An object of the present solution is to provide a new method and a rock bolt for drilling a drill hole in a material to be drilled, such as a rock material, and reinforcing the material, such as the rock material, surrounding the drill hole. The objects of the solution are achieved by a method and a rock bolt, which are characterized by what is stated in the independent claims. Some embodiments of the invention are disclosed in the dependent claims.

The solution is based on the idea of providing a self-drilling rock bolt comprising an anchor element that mechanically anchors the rock bolt in the drill hole. This is very beneficial, because no separate drilling tool is needed and the rock bolt is immediately anchored in the drill hole, both of which save time in the process as unnecessary work phases and waiting times can be avoided.

Some other advantages of the solution are discussed in connection with the detailed description.

BRIEF DESCRIPTION OF THE DRAWINGS

In the following the invention will be described in greater detail by means of preferred embodiments with reference to the accompanying drawings, in which

Figure 1 illustrates a rock bolt;

Figure 2 illustrates schematically a rock bolt in a drill hole;

Figure 3 illustrates schematically a detail of an embodiment of the rock bolt in a drill hole;

Figures 4a, 4b and 4c illustrate details of other embodiments of the

rock bolt;

Figure 5 illustrates an embodiment of a rock bolt;

Figure 6 illustrates a detail of the section A of the rock bolt of Figure 5;

Figure 7 illustrates a detail of the section B of the rock bolt of Figure 5;

Figure 8 illustrates a detail of the section C of the rock bolt of Figure 5;

and

Figure 9 illustrates a method for drilling a drill hole and reinforcing the material surrounding the drill hole by a self-drilling rock bolt.

DETAILED DESCRIPTION OF THE INVENTION

Figure 1 illustrates schematically a rock bolt for reinforcing material surrounding a drill hole.

The rock bolt 1 in the embodiment of Figure 1 comprises a self-drilling rock bolt. Such a self-drilling rock bolt 1 can be used for drilling a drill hole 2 in a material to be drilled 3, such as a rock material, and/or reinforcing the material, such as the rock material, surrounding the drill hole 2. A percussive and/or rotative rock drill (not shown) can be utilised to enable the drilling of the drill hole. More particularly, the rock drill may be used to provide the impact and the rotation needed for the drilling.

The rock bolt 1 may comprise drilling means 4 for drilling a drill hole in a material to be drilled. The drilling means 4 may be provided at a drilling end 7 of the rock bolt. In other words, the rock bolt 1 may thus be a self-drilling rock bolt. Thereby, no separate drilling tool is needed and unnecessary work phases can be avoided as there is no need to remove the drilling tool from the drill hole and to insert a separate rock bolt to the drilled hole for reinforcing the drilled material. In the figures, the drilling means 4 are shown schematically only, but different types of drilling means, such as different types of drill bits, are generally known in the art and are not described here in more detail.

The rock bolt 1 may comprise a rock bolt body 5 for bolting the drill hole 2. The rock bolt body 5 can also be used to reinforce the material surrounding the drill hole 2.

The rock bolt 1 may comprise a connecting end 8 at the end of the rock bolt 1 opposite to the drilling end 7. In other words, the connecting end 8 may be provided at the end of the rock bolt 1 facing towards the mining machine (not shown), when the rock bolt 1 is assembled in a use position in the mining machine.

The rock bolt 1 may further comprise an end anchor element 9 provided at the drilling end 7 of the rock bolt. The end anchor element 9 may be arranged to engage with the material of the drill hole 2 walls to anchor the rock bolt 1 in the drill hole.

According to an embodiment, the end anchor element 9 may comprise an anchor shell 10 mounted on the rock bolt body 5 and provided with anchor means for engaging with the material of the drill hole 2 walls. The anchor means may be arranged to protrude from the rock bolt body 5 at least when a force pulling the rock bolt 1 backwards and away from the bottom of the drill hole 2 is applied to the rock bolt, such that a drilling motion of the rock bolt directed forward towards the bottom of the drill hole forces the anchor means towards the longitudinal axis B of the end anchor element 9. Stopping of the forward drilling motion or moving the rock bolt 1 in a direction opposite to direction A of the forward drilling motion may enable the anchor means to be pushed outward from the longitudinal axis B of the end anchor element. This may cause the anchor means to engage with the material of the drill hole walls to anchor the end anchor element 9 in its place in the drill hole 2 and to prohibit pulling of the rock bolt 1 out from the drill hole 2. In other words, the diameter of the end anchor element 9 may be arranged to increase at least at one point of the end anchor element 9 in response to the ending of a force applied to the rock bolt 1 to push the rock bolt 1 towards the material to be drilled, in other words towards the bottom of the drill hole, and/or in response to starting of a force pulling the rock bolt 1 outwards from the drill hole 2. According to an embodiment, the anchor means may comprise an anchor member 11.

According to an embodiment, the end anchor element may comprise activating means. The activating means may comprise means for enabling the anchor means to be pushed outward from the longitudinal axis B of the end anchor element and to engage with the material to be drilled 3, such as rock material, of the drill hole walls to anchor the end anchor element 9 in its place in the drill hole 2 and to prohibit pulling the rock bolt 1 out from the drill hole 1. According to an embodiment, the activating means may comprise an activating member 12.

According to an embodiment, the anchor shell 10 may comprise two separate wedge-like parts. In other words, the anchor shell 10 may be formed of two anchor shell halves 10a, 10b. The anchor shell halves 10a, 10b may be arranged against one another to form a cylindrical anchor shell, such that the con-

tact surface 19 between the anchor shell halves 10a, 10b extends in an angled manner when compared to the longitudinal axis B of the end anchor element. The contact surface 19 may extend between opposite sides of the outer edge of the anchor shell 10 and between opposite ends of the anchor shell 10, namely the end directed towards the drilling end 7 and the end directed towards the connecting end 8, in the direction of longitudinal axis B of the end anchor element 9.

According to an embodiment, the anchor means may comprise the two halves 10a, 10b of the anchor shell instead of or in addition to an anchor member 11.

According to an embodiment, the anchor shell halves 10a, 10b may be arranged at least partly adjacent to one another in the longitudinal direction B of the end anchor element. Thus, the anchor means may be pushed outward from the longitudinal axis B of the end anchor element and to engage with the material to be drilled 3, such as the rock material, of the drill hole walls by enabling the anchor shell half closer to the bottom of the drill hole, in other words a second anchor shell half 10b, to slide partly on top of the other anchor shell half, in other words a first anchor shell half 10a, whereby the diameter C of the anchor shell is increased.

According to an embodiment, the cross section of the anchor shell 10 may be formed in such a way that it allows flushing media to flow pass the anchor shell 10 in the drill hole 2. In other words, the cross section of the anchor shell 10 may be smaller than the diameter of the drill hole 2 in at least one direction, such that the flushing media may flow between the anchor shell 10 and the wall(s) of the drill hole 2. According to an embodiment, the cross section of the anchor shell 10 may be formed as an ellipse or some other non-rotational symmetric form. This may enhance the flushing, for example, as the diameter of the anchor shell with the anchor shell halves arranged against one another should be quite close to the diameter of the drill hole and, therefore, effective flushing is harder to be arranged with a round cross section, for example. In addition, with the ellipse cross section of the anchor shell, also the cuttings have more space to bypass the end anchor element. The anchor shell halves 10a, 10b may be formed to provide a cavity 22 extending in the longitudinal direction of the end anchor element inside the anchor shell 10. Thereby, the rock bolt body 5 may be arranged inside the anchor shell 10 formed by the anchor shell halves 10a, 10b.

According to an embodiment, the activating member 12 may comprise a spring arranged to affect at least one of the anchor shell halves 10a, 10b. An ex-

ample of such an embodiment is shown in the Figure 5. According to an embodiment, the spring may be arranged to continuously push the first anchor shell half 10a arranged at the outer end of the end anchor element 9, that is the end directed away from the bottom of the drill hole 2 and towards the outside of the drill hole 2, forward towards the second anchor shell half 10b. In other words, the first anchor shell half 10a may comprise the anchor shell half further away from the drilling means 4. The activating member 12, such as the spring, may, thus, be arranged to tend to increase the diameter C of the anchor shell 10, in other words the diameter of the pair of anchor shell halves 10a, 10b, to engage with material to be drilled 3, such as the rock material, of the drill hole walls to anchor the end anchor element 9 in its place in the drill hole 2 and to prohibit pulling the rock bolt 1 out from the drill hole 2.

According to an embodiment, the end anchor element 9 further comprises retention means for keeping the anchor shell halves from sliding on top of one another during drilling. According to an embodiment, the retention means may comprise a flange 24 arranged at the end of the second anchor half 10b directed towards the bottom of the drill hole and, as a counterpart for the flange, a shoulder 25 arranged at the rock bolt body at the drill bit end of the rock bolt body. An embodiment of such a rock bolt 1 is shown in Figure 5, wherein the flange 24 and the shoulder 25 are provided in the area of the section A. Figure 6 illustrates the detail of the section A of the rock bolt of Figure 5 in more detail by providing an enlarged view of the section A.

According to an embodiment, an impact absorber 26, such as an impact sleeve, may be arranged between the rock bolt body 5 and the end anchor element 9 to dampen the impact from percussive drilling. Thus, the impact absorber may be arranged to dampen the impact from the percussive drilling between the rock bolt body 5 and the anchor shell 10. In other words, the impact absorber 26 may be arranged to prevent direct impact between the rock bolt body 5 and the anchor shell 10 at the drilling end of the rock bolt 1. This prevents deformation of the rock bolt body 5 and the anchor shell 10 from damage induced by percussive force, for instance wearing of the shoulder 25.

According to an embodiment, the impact absorber 26 may be provided at the drilling end 7 of the rock bolt body for dampening the impact from percussive drilling. According to an embodiment, the impact absorber 26 may be provided in the end anchor element 9.

According to an embodiment, the impact absorber 26, such as the im-

impact sleeve, may form an impact shoulder of the rock bolt body acting as a counterpart for the end anchor element 9, for instance more particularly for the anchor shell 10. In such an embodiment the impact shoulder may, thus, form the shoulder 25 acting as a counterpart for the flange 24 of the retention means. In other words in such an embodiment, the shoulder 25 may be formed in the impact absorber 26 instead of the rock bolt body 5.

According to an embodiment, the impact absorber 26 may be formed of a material that is less hard than the rock bolt body 5 and/or end anchor element 9, such as the anchor shell 10, for instance the anchor shell halves 10a, 10b. In other words, the impact absorber may be formed of a material more easily deformed or deformed by less power than the material of the rock bolt body and/or the anchor shell. The impact absorber might be for instance formed of copper. Thereby, the impact absorber may prevent percussive stress waves from destroying the contact surfaces of the rock bolt body and the anchor shell, such as the flange 24 of the second anchor half 10b.

According to an embodiment, the impact absorber may comprise a spring-like structure instead of or in addition to an impact sleeve. In such an embodiment, the structure of the impact absorber 26 may dampen the impact from percussive drilling instead of or in addition to the selected material of the impact absorber as explained in connection with the impact sleeve.

According to an embodiment, the end anchor element 9 may further comprise a starter ring 20 or some other type of a binding structure arranged around the anchor shell halves 10a, 10b or at least partly surrounding the anchor shell halves 10a, 10b to keep the anchor shell halves against one another before entering the drill hole. The binding structure, such as the starter ring 20, may be arranged to disengage from the anchor shell halves when the anchor shell 10 enters the drill hole. This may be implemented for instance by welding the binding structure, such as the starter ring 20, or mounting binding structure, such as the starter ring 20, to at least one of the anchor shell halves 10a, 10b in a releasable manner, such that the force of the anchor shell 10 entering the drill hole is sufficient for disengaging the binding structure from the anchor shell 10.

According to an embodiment, the anchor means may further comprise at least one protruding member 23 arranged on the first anchor shell half 10a closer to the connecting end 8 to engage with the drill hole wall to enhance said sliding of the anchor shell halves 10a, 10b on top of one another. According to an embodiment, the protruding member 23 may comprise a wing-like protrusion

arranged in the first anchor shell half 10a. The protruding member 23 may be arranged to provide more initial pull-out resistance for the end anchor element 9 when compared to a smooth anchor shell 10 comprising two anchor shell halves 10a, 10b. This initial friction enhances the start of the anchor shell halves 10a, 10b sliding on the top of each other creating the increase in the diameter C of the anchor shell and the end anchor element at least at one point of the end anchor element and, thus, the end anchor element 9 engaging with the material to be drilled 3 and thereby providing the pull-out resistance. An example of such an embodiment is shown in Figure 5, wherein the protruding member 23 is provided in the area of the section B. Figure 7 illustrates the detail of the section B of the rock bolt of Figure 5 in more detail by providing an enlarged view of the section B.

According to an embodiment, the anchor means may comprise a mechanically activated anchor member 11. The activating member 12 may be arranged to mechanically activate the anchor member 11 to protrude from the anchor shell 10, such that a motion of the rock bolt 1 directed forward towards the bottom of the drill hole, such as a drilling motion, forces the anchor member 11 backwards with respect to direction of the motion of the rock bolt 1 and towards the longitudinal axis of the end anchor element 9. This motion directed forward towards the bottom of the drill hole 2, also called forward motion or forward drilling motion, is shown in Figure 2 by an arrow A. On the other hand, stopping of the forward motion or moving the rock bolt 1 in a direction opposite to the direction A of the forward motion may enable the anchor member 11 to be pushed forward and outward to engage with the material of the drill hole 2 walls to anchor the end anchor element 9 in its place in the drill hole 2 and to prohibit pulling the rock bolt 1 out from the drill hole.

The drilling means 4 may be provided at the end anchor element 9 at the drilling end 7 of the rock bolt 1.

According to an embodiment, at least one flushing channel 6 may be provided in the rock bolt 1 for guiding flushing fluid into the drill hole 2. The one or more flushing channels 6 of the rock bolt body 5 may also extend to the end anchor element 9, such that the flushing fluid can be provided in the drill hole 2. According to an embodiment, several flushing channels 6 may be provided in the rock bolt 1. Preferably, at least one flushing channel 6 extends through the rock bolt body 5 and the end anchor element 9 and through the drilling end 7 of the rock bolt 1, such that flushing fluid can be directed to the bottom of the drill hole

2.

According to an embodiment, the drilling means 4 may be formed as a fixed part of the anchor shell 10. In other words, the drilling means 4 may be fixedly arranged to the anchor shell 10. According to another embodiment, the drilling means 4 may be formed as a fixed part of the rock bolt body 5. According to a further embodiment, the drilling means 4 may be attached detachably to the anchor shell 10 and/or the rock bolt body 5.

According to an embodiment, the anchor member 11 may comprise a wedge-like shape such that the cross-section of the drilling end 7 side end of the anchor member 11 is smaller than the cross-section of the connecting end 8 side end of the anchor member 11.

According to an embodiment, the cross-section of the anchor member 11 may comprise a rectangular shape on the side of the anchor shell 10 and rounded on the outer edge to align with the outer shape of the anchor shell 10. The anchor member 11 may be formed such that the anchor member 11 can be arranged to the anchor shell 10 in such a manner that the anchor member 11 and the anchor shell 10 form a continuous shape without protrusions. According to another embodiment, the anchor member 11 may comprise a round shape.

According to an embodiment, the anchor member 11 may be mechanically activated by an activating member 12, such that the activating member 12 is arranged to push the anchor member 11 to protrude from the anchor shell 10 when no external forces act on the end anchor element 9, such as when the rock bolt 1 is not moved forward in the drill hole 2. It is clear for a person skilled in the art that the same applies to situations where the mechanical activating force pushing the anchor member 11 to protrude from the anchor shell 10 is higher than the external force pushing it inwards and backwards, but in such a situation the force with which the anchor member 11 engages with the walls of the drill hole 2 is smaller. This also applies for the other embodiments described in this document and accompanying drawings and claims.

According to an embodiment, the activating member 12 may comprise a spring member mounted between the anchor shell 10 and the anchor member 11 in an angled manner, such that the spring member is arranged to push the anchor member to protrude from the anchor shell when no external forces act on the end anchor element 9. In other words, when the rock bolt 1 is pushed in a forward motion inwards in the drill hole 2, the movement and the drill hole walls apply to the rock bolt 1 and the anchor member 11 a force working against the

springback factor of the spring member and pushing the anchor member 11 inwards and backwards into its place in the anchor shell 10. When the forward motion of the rock bolt 1 stops, no external force working against the springback factor of the spring member pushes the anchor member 11 inwards and backwards. This results in the anchor member 11 protruding from the anchor shell 10 and engaging with the walls of the drill hole 2. An example of such an embodiment is shown in more detail in Figure 3.

According to an embodiment, the anchor member 11 may be activated by some other means, such as hydraulically by using flushing water channel directed to the rear end of the anchor member 11 and thus creating a forward force which pushes the anchor member 11 into the contact of the rock wall. The water may be led to an anchor-shell-side surface of the anchor member 11. The working principle of the anchor member 11, the anchor shell 10 and the activating member 12 may be similar to the spring member embodiment, but instead of the spring member, the activating member 12 may comprise means for providing pressurized water to an anchor-shell-side surface of the anchor member 11 to provide the force pushing the anchor member 11 forwards and outwards from the anchor shell 10.

Figures 4a, 4b and 4c illustrate details of other embodiments of the rock bolt 1. Figures 4a, 4b and 4c illustrate a detail of two embodiments of the rock bolt 1, wherein the anchor shell 10 and the anchor member 11 may be provided with guiding means 13a, 13b for guiding the direction of the mechanically activated movement of the anchor member 11 with respect to the anchor shell 10. Figure 4a illustrates an example of such an embodiment from a side of the rock bolt 1 and Figures 4b and 4c illustrate a detail of a cross section of two different alternative embodiments of the guiding means 13a, 13b.

According to an embodiment, such as one of the embodiments of the figures 4a, 4b and 4c, the guiding means may comprise a groove 13a provided in one of the anchor shell 10 and the anchor member 11 and a protrusion 13b fitting in the groove 13a provided in the other. The groove 13a and the protrusion 13b may extend in the direction of the outward movement of the anchor member 11 to guide its movement. This way it can be ensured that the anchor member 11 moves in the predetermined direction with respect to the anchor shell 10 to engage with the walls of the drill hole 2 in an optimal manner. In the embodiment of Figure 4b, the groove 13a and the protrusion 13b have a rectangular cross-section and, in the Figure 4c, the groove 13a and the protrusion 13b have a dove-

tail-shape cross-section. According to a further embodiment, the groove 13a and the protrusion 13b may also have a cross-section of another shape, such as rounded or half-circle-shaped. The dovetail-shaped joint of Figure 4c has the benefit that it guides the direction of movement of the anchor member 11 in two linear directions. A rectangular or rounded joint, on the other hand, does not limit the movement of the anchor member 11 in the radial direction of the end anchor element 9, in other words in the direction away from the longitudinal axis B of the end anchor element 9. However, the drill hole 2 usually restricts the movement of the anchor member 11 in this direction during drilling.

According to an embodiment, the end anchor element 9 may be arranged to the rock bolt body 5 by thread (not shown) or by some other detachable manner. In other words, the end anchor element may be mounted to the rock bolt body 5 in a removable manner.

According to an embodiment, the end anchor element 9 may be arranged to the rock bolt body 5 fixedly, for instance by welding.

According to an embodiment, a sliding surface 14 may be formed between the anchor shell 10 and the anchor member 11. The friction coefficient of this sliding surface 14 may be smaller than that of the rest of the surfaces of the anchor shell 10 and the anchor member 11, for example. Thereby, the friction between the anchor shell 10 and the anchor member 11 can be decreased to enhance the movement of the anchor member 11 both inwards and outwards with respect to the anchor shell 10. According to an embodiment, such a sliding surface may be formed between the first anchor shell half 10a and the second anchor shell half 10b.

According to an embodiment, the outer surface of the anchor member 11 is formed to be smooth, for instance substantially equally smooth as the outer surface of the anchor shell 10. In other words, the friction between the outer surface of the anchor member 11 and the material to be drilled, such as the rock material, may be substantially equal to the friction between the anchor shell 10 and the material to be drilled. The outer surface of the anchor member 11 refers to the surface of the anchor member 11 directed outwards from the anchor shell 10 and towards the wall of the drill hole 2 to engage with the wall. This may enable a smooth movement of the anchor member 11 and the anchor shell 10 during drilling.

According to an embodiment, the outer surface of the anchor member 11 is roughened such that the friction between the outer surface of the anchor

member 11 and the material to be drilled, such as the rock material, is higher than the friction between the anchor shell 10 and the material to be drilled at least when the rock bolt is moved in the direction opposite to the forward motion, such as the drilling motion, of the rock bolt 1. In other words, the outer surface of the anchor member 11 may be roughened in such a manner that the friction between the anchor member 11 and the material to be drilled is higher than the friction between the anchor shell 10 and the material to be drilled at least when the drill hole 2 has been drilled and the rock bolt 1 is pulled backwards to anchor the rock bolt 1 in the drill hole. According to an embodiment, the friction between the anchor member 11 and the material to be drilled may be higher while the rock bolt 1 is pulled backwards than when the rock bolt 1 is pushed inwards to the drill hole 2. This decreases the friction when the rock bolt 1 is moved into the drill hole 2 for instance during drill, while a sufficient friction for anchoring the rock bolt 1 in the drill hole 2 can be provided when the movement is stopped and/or the rock bolt 1 is pulled outwards.

According to an embodiment, the rock bolt 1 may comprise at the connecting end 8 an impact part 15 for receiving impacts from the rock drill. The impact part may comprise a flat end surface 16 facing towards the rock drill. According to an embodiment, the impact part 15 may comprise a circular cross-section. According to another embodiment, the impact part 15 may comprise a polygonal, such as a rectangular or hexagonal, cross-section.

According to an embodiment, the rock bolt 1 may comprise at the connecting end 8 a rotating part 17 provided adjacent to the impact part 15 for transmitting the rotation provided by the rock drill to the rock bolt 1. Thereby the rock bolt 1 can be used for rotative drilling. The rock bolt 1 can, thus, be used in connection with percussive and/or rotative drilling. According to an embodiment, the rotating part 17 may comprise a polygonal cross-section, such as a hexagonal cross-section. An embodiment of a rock bolt 1 comprising such a rotating part 17 is shown schematically in Figure 2. According to another embodiment, the rotating part 17 may comprise other type of a cross-section enabling transmitting of the rotation provided by the rock drill to the rock bolt 1, such as a cross-section comprising a groove or protrusion interlocking with the rock drill.

According to an embodiment, the rock bolt 1 may comprise a stopper section (not shown) and the rotating part 17 may comprise a nut mountable to the rock bolt body 5 by a thread (not shown). The handedness of the thread may be selected such that the thread opens in a direction opposite to that of the direc-

tion of rotation of the drilling of the rock drill, such that the rock bolt 1 anchored in the drill hole 2 by the anchor member 11 can be tensioned by rotating the rock drill in a direction opposite to the direction of rotation of the drilling. The stopper section of the bolt may then deliver the needed rotation torque to the rock bolt and prevent the nut from being screwed off. After the drill hole reaches its intended depth, the rock bolt 1 can be end anchored with the self-drilling rock bolt and specifically by the end anchor element. The rock bolt may then be tensioned by rotating the shank clockwise driving the nut against the rock and tension it. According to a further embodiment, the rock bolt may further be grouted with resin or cement through the shank.

According to an embodiment, the rotating part 17 may comprise a right-handed thread and during drilling the rock bolt 1 may be turned counterclockwise. Thus, the rotating part 17 does not open during drilling, but the rotating part 17 transfers the rotating motion of the rock drill to the rock bolt 1.

According to an embodiment, the rock bolt 1 is provided with an end plate 18. Then, the rock bolt 1 can be tensioned, in other words pretensioned, in the drill hole 2 by turning the rock bolt in clockwise as is explained in more detail in connection with the method.

According to an embodiment, the rotating part 17 may comprise a left-handed thread and during drilling the rock bolt 1 may be turned clockwise. The rock bolt 1 may then be provided with an end plate 18 and the rock bolt 1 can be tensioned in the drill hole 2 by turning the rock bolt in counterclockwise as is explained in more detail in connection with the method.

Figure 9 illustrates a method for drilling a drill hole 2 in material to be drilled, such as a rock material, and reinforcing the material, such as the rock material, surrounding the drill hole 2 by a self-drilling rock bolt 1. A percussive and/or rotative rock drill may be used in the drilling and reinforcing. The rock bolt 1 may comprise a rock bolt 1 as described in the embodiments of this description. The method may comprise drilling 901 a drill hole 2 in a material to be drilled by drilling means 4 provided at a drilling end 7 of the rock bolt 1. The method may also comprise bolting 902 the drill hole 2 by a rock bolt body 5 of the rock bolt 1. The method may further comprise anchoring 904 an end anchor element 9 of the rock bolt 1 in its place in the drill hole 2 and prohibiting 905 by the end anchor element 9 pulling the rock bolt 1 out from the drill hole 2. According to an embodiment, the method may further comprise guiding 903 flushing fluid into the drill hole 2 by at least one flushing channel 6 provided in the body of the

rock bolt.

The end anchor element 9 may be provided at the drilling end 7 of the rock bolt 1 and comprise an anchor shell 10 mounted on the rock bolt body 5 and provided with an anchor means for engaging with the material of the drill hole 2 walls. The anchor means may be arranged to protrude from the rock bolt body at least when a force pulling the rock bolt backwards and away from the bottom of the drill hole is applied to the rock bolt, such that a drilling motion of the rock bolt 1 directed forward towards the bottom of the drill hole 2 forces the anchor means towards the longitudinal axis B of the end anchor element 9, whereas stopping of the forward drilling motion or moving the rock bolt 1 in a direction opposite to the forward drilling motion may enable the anchor means to be pushed outward from the longitudinal axis of the end anchor element and to engage with the material of the drill hole 2 walls for anchoring the rock bolt 1 in its place in the drill hole 2. The drilling means 4 may be provided at the end anchor element at the drilling end of the rock bolt.

According to an embodiment, the method may further comprise providing the impact for the drilling of the drill hole 2 by receiving by an impact part 15 provided at the connecting end 8 of the rock bolt 1 and comprising a flat end surface 16 facing towards the rock drill impacts from the rock drill. The method may also comprise providing the rotation for the drilling of the drill hole 2 by transmitting the rotation produced by the rock drill to the rock bolt 1 by a rotating part 17 provided adjacent to the impact part 15. According to an embodiment, the impact part 15 may comprise a polygonal cross-section, such as a hexagonal cross-section.

According to an embodiment, the rock bolt may comprise a stopper section 27 and the rotating part 17 may comprise a nut mountable to the rock bolt body 5 by a thread (not shown) and wherein the handedness of the thread is selected such that the thread opens in a direction opposite to that of the direction of rotation of the drilling of the rock drill, such that the rock bolt 1 anchored in the drill hole by the anchor member 11 can be tensioned by rotating the rock drill in a direction opposite to the direction of rotation of the drilling. The method may also comprise providing the needed rotation torque for the drilling of the drill hole 2 by the stopper section preventing the nut from being screwed out while transmitting the rotation provided by the rock drill to the rock bolt 1 by the rock drill and the rotating part 17. The method may further comprise providing an end plate 18 outside the drill hole 2 and against the material to be drilled and engag-

ing with the surface of the material to be drilled, and tensioning the rock bolt 1 by rotating the rock drill in a direction of rotation opposite to that used for drilling the drill hole after anchoring the end anchor in its place in the drill hole 2. Thereby, the end plate 18 and the nut are tensioned against the surface of the material to be drilled.

According to an embodiment, the method may further comprise feeding grout through the flushing channel into the drill hole 2 and/or into rock mass fissures after the anchor member and the anchor shell have anchored the rock bolt into the drill hole. According to an embodiment, grout may be fed after the rock bolt has been tensioned. According to an embodiment, the grout may comprise cement or resin. As the rock bolt 1 is anchored in the drill hole 2 by the anchor element 11 and not the resin, a type of resin that is slow to harden can be used. This makes it easier to manage the injecting of the resin and cleaning up the equipment used for injecting the resin before the resin hardens.

It will be obvious to a person skilled in the art that, as the technology advances, the inventive concept can be implemented in various ways. The invention and its embodiments are not limited to the examples described above but may vary within the scope of the claims.

CLAIMS

1. A self-drilling rock bolt (1) for drilling a drill hole (2) in a material to be drilled (3) and reinforcing the material surrounding the drill hole using a percussive or rotative rock drill, the rock bolt comprising

drilling means (4) for drilling a drill hole in a material to be drilled at a drilling end (7) of the rock bolt,

a rock bolt body (5) for bolting the drill hole,

a connecting end (8) at the end of the rock bolt opposite to the drilling end and facing towards the mining machine, and

an end anchor element (9) provided at the drilling end of the rock bolt and comprising

an anchor shell (10) mounted on the rock bolt body and provided with anchor means for engaging with the material of the drill hole walls, wherein the anchor means is arranged to protrude from the rock bolt body at least when a force pulling the rock bolt backwards and away from the bottom of the drill hole is applied to the rock bolt, such that a drilling motion of the rock bolt directed forward towards the bottom of the drill hole forces the anchor means towards the longitudinal axis of the end anchor element, whereas stopping of the forward drilling motion or moving the rock bolt in a direction opposite to the forward drilling motion enables the anchor means to be pushed outward from the longitudinal axis of the end anchor element and to engage with the material of the drill hole walls to anchor the end anchor element in its place in the drill hole and to prohibit pulling the rock bolt out from the drill hole, wherein

the drilling means are provided at the end anchor element at the drilling end of the rock bolt, **characterized** in that,

the anchor means comprise two halves of the anchor shell (10) formed as separate wedge-like parts and arranged against one another to form a cylindrical anchor shell, such that the contact surface (19) between the anchor shell halves (10a, 10b) extends in an angled manner when compared to the longitudinal axis of the end anchor element between the outer edge of the anchor shell at one side at one end of the anchor shell and the outer edge of the anchor shell at the opposite side at the another end of the anchor shell, such that the anchor means may be pushed outward from the longitudinal axis of the end anchor element and to engage with the material of the drill hole walls by enabling the anchor shell half closer to the bottom of the drill hole to slide partly on top of the

other anchor shell half, whereby the diameter of the anchor shell is increased, and that

the end anchor element further comprises activating means comprising means for enabling the anchor means to be pushed outward from the longitudinal axis (B) of the end anchor element and to engage with the material to be drilled (3) of the drill hole walls to anchor the end anchor element (9) in its place in the drill hole (2) and to prohibit pulling the rock bolt (1) out from the drill hole.

2. A self-drilling rock bolt according to claim, wherein the cross section of the anchor shell (10) is formed as an ellipse.

3. A self-drilling rock bolt according to claim 1 or 2, wherein the end anchor element (9) further comprises retention means for keeping the anchor shell halves (10a, 10b) from sliding on top of one another during drilling.

4. A self-drilling rock bolt according to any one of claims 1-3, wherein the end anchor element (9) further comprises a starter ring (20) arranged around the anchor shell halves (10a, 10b) to keep the anchor shell halves against one another before entering the drill hole (2) and that is arranged to disengage from the anchor shell halves when the anchor shell (10) enters the drill hole.

5. A self-drilling rock bolt according to any one of claims 1-4, wherein the anchor means further comprises at least one protruding member (23) arranged on the anchor shell half (10a) closer to the connecting end (8) to engage with the drill hole wall to enhance said sliding of the anchor shell halves (10a, 10b) on top of one another.

6. A self-drilling rock bolt according to claim 1, wherein the anchor means comprise a mechanically activated anchor member (11) that is mechanically activated by an activating member (12), such that the activating member is arranged to push the anchor member to protrude from the anchor shell when no external forces act on the end anchor element (9).

7. A self-drilling rock bolt according to claim 6, wherein the activating member (12) comprises a spring member mounted between the anchor shell (10) and the anchor member (11) in an angled manner, such that the spring member is arranged to push the anchor member to protrude from the anchor shell when no external forces act on the end anchor element (9).

8. A self-drilling rock bolt according to any one of claims 1 to 7, wherein the end anchor element (9) is arranged to the rock bolt body

(5) by thread.

9. A self-drilling rock bolt according to any one of claims 1 to 7, wherein the end anchor element (9) is arranged to the rock bolt body (5) fixedly by welding.

10. A self-drilling rock bolt according to any one of claims 1 to 9, wherein the friction between the outer surface of the anchor shell (10) and the material to be drilled (3) is higher than the friction between the rock bolt body (5) and the material to be drilled at least when the rock bolt is moved in the direction opposite to the forward drilling motion.

11. A self-drilling rock bolt according to any one of claims 1 to 10, wherein the rock bolt comprises at the connecting end (8) an impact part (15) for receiving impacts from the rock drill and comprising a circular cross-section and a flat end surface (16) facing towards the rock drill, and a rotating part (17) provided adjacent to the impact part and comprising a polygonal cross-section for transmitting the rotation of the rock drill to the rock bolt.

12. A self-drilling rock bolt according to claim 11, wherein the rock bolt comprises a stopper section (27) and the rotating part (17) comprises a nut mountable to the rock bolt body (5) by a thread, and wherein the handedness of the thread is selected such that the thread opens in a direction opposite to that of the direction of rotation of the drilling of the rock drill, such that the rock bolt anchored in the drill hole (2) by the anchor member (11) can be tensioned by rotating the rock drill in a direction opposite to the direction of rotation of the drilling.

13. A method for drilling a drill hole (2) in a material to be drilled (3) and reinforcing the material surrounding the drill hole by a self-drilling rock bolt utilizing a percussive or rotative rock drill, the method comprising

drilling a drill hole in a material to be drilled by drilling means (4) provided at a drilling end (7) of the rock bolt, and

bolting the drill hole by a rock bolt body (5) of the rock bolt,

characterized by the method further comprising

anchoring an end anchor element (9) of the rock bolt in its place in the drill hole and prohibiting by the end anchor element pulling the rock bolt out from the drill hole, wherein

the end anchor element is provided at the drilling end of the rock bolt and comprises

an anchor shell (10) mounted on the rock bolt body and provided with

anchor means for engaging with the material of the drill hole walls, wherein the anchor means is arranged to protrude from the rock bolt body at least when a force pulling the rock bolt backwards and away from the bottom of the drill hole is applied to the rock bolt, such that a drilling motion of the rock bolt directed forward towards the bottom of the drill hole forces the anchor means towards the longitudinal axis of the end anchor element, whereas stopping of the forward drilling motion or moving the rock bolt in a direction opposite to the forward drilling motion enables the anchor means to be pushed outward from the longitudinal axis of the end anchor element and to engage with the material of the drill hole walls for anchoring the rock bolt in its place in the drill hole,

wherein the anchor means comprise two halves of the anchor shell formed as separate wedge-like parts and arranged against one another to form a cylindrical anchor shell, such that the contact surface (19) between the anchor shell halves (10a, 10b) extends in an angled manner when compared to the longitudinal axis of the end anchor element between the outer edge of the anchor shell at one side at one end of the anchor shell and the outer edge of the anchor shell at the opposite side at the another end of the anchor shell, such that the anchor means may be pushed outward from the longitudinal axis of the end anchor element and to engage with the material of the drill hole walls by enabling the anchor shell half closer to the bottom of the drill hole to slide partly on top of the other anchor shell half, whereby the diameter of the anchor shell is increased, and

wherein end anchor element further comprises activating means comprising means for enabling the anchor means to be pushed outward from the longitudinal axis (B) of the end anchor element and to engage with the material to be drilled (3) of the drill hole walls to anchor the end anchor element (9) in its place in the drill hole (2) and to prohibit pulling the rock bolt (1) out from the drill hole, and by

the drilling means (4) being provided at the end anchor element at the drilling end of the rock bolt.

14. A method according to claim 13, wherein the method further comprises

providing the impact for the drilling of the drill hole (2) by receiving by an impact part (15) provided at the connecting end (8) of the rock bolt and comprising a circular cross-section and a flat end surface (16) facing towards the rock drill impacts from the rock drill, and

providing the rotation for the drilling of the drill hole by transmitting the rotation provided by the rock drill to the rock bolt by a rotating part (17) provided adjacent to the impact part and comprising a polygonal cross-section.

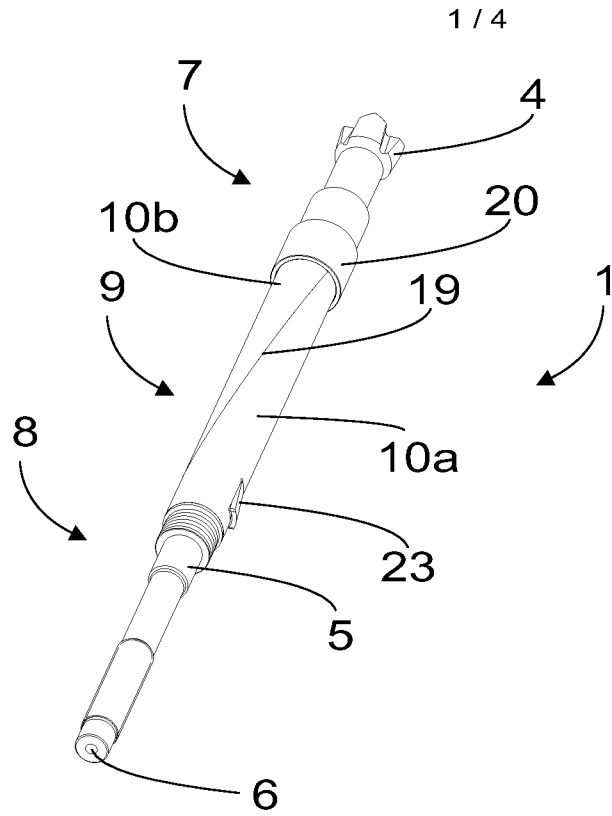

FIG. 1

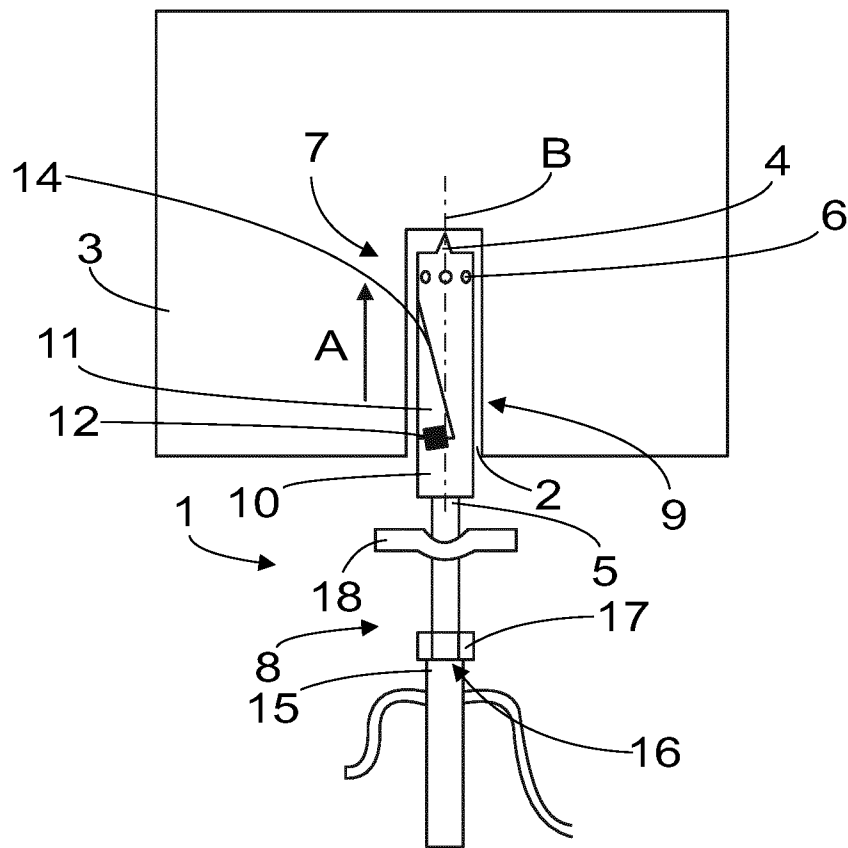

FIG. 2

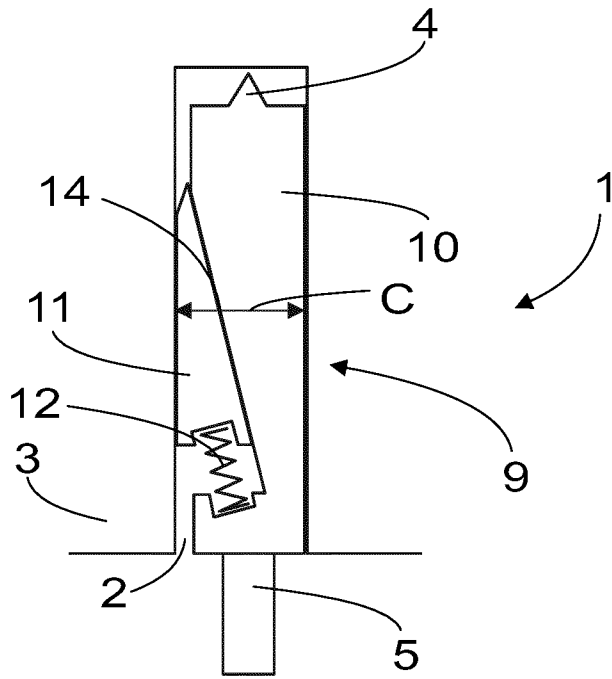

FIG. 3

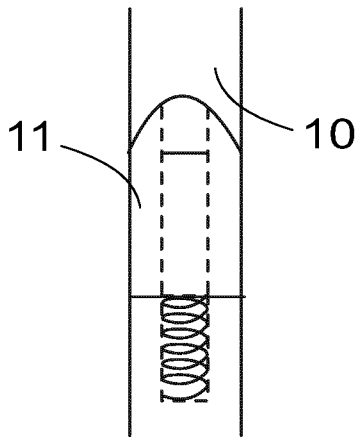

FIG. 4a

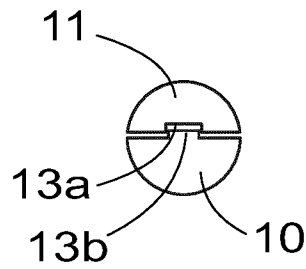

FIG. 4b

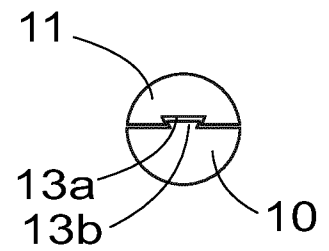

FIG. 4b

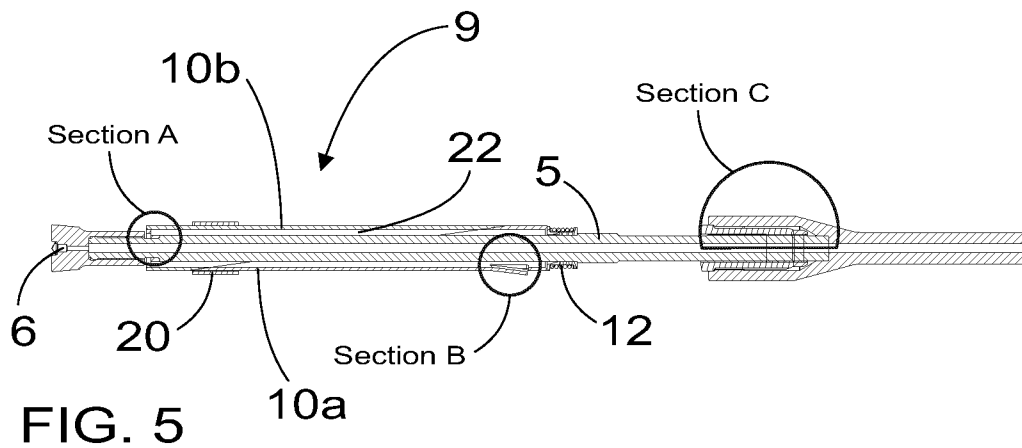

FIG. 5

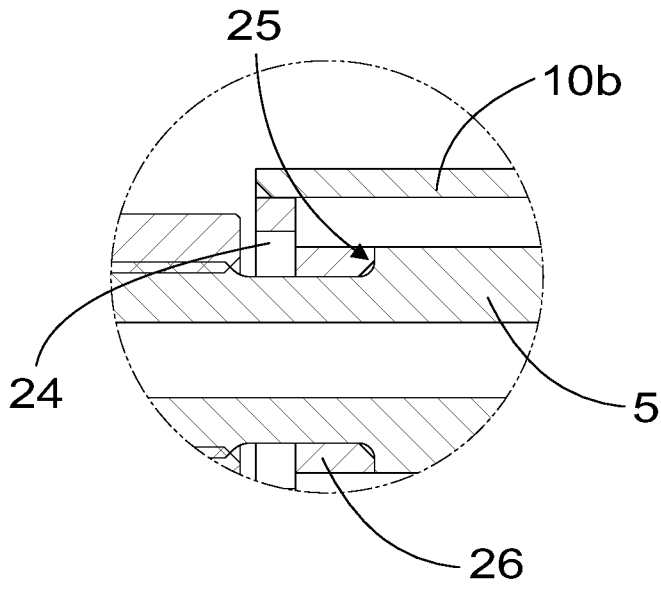

FIG. 6

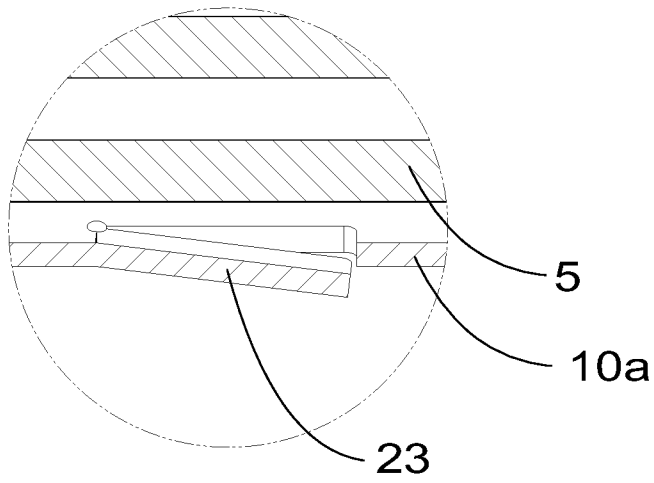

FIG. 7

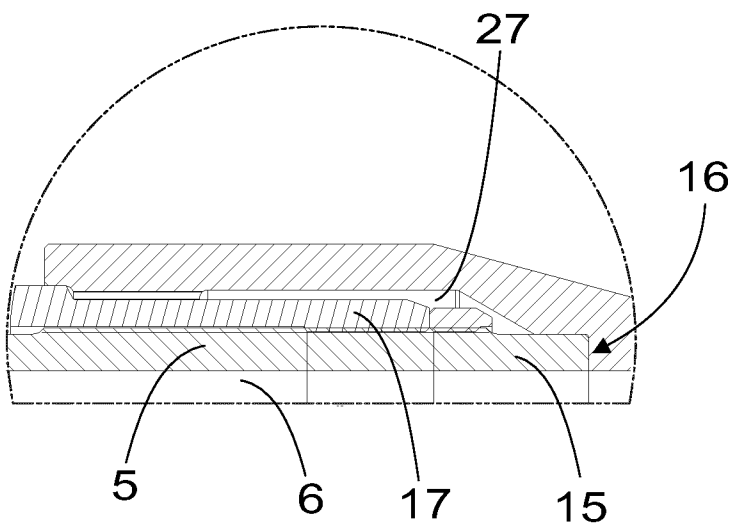

FIG. 8

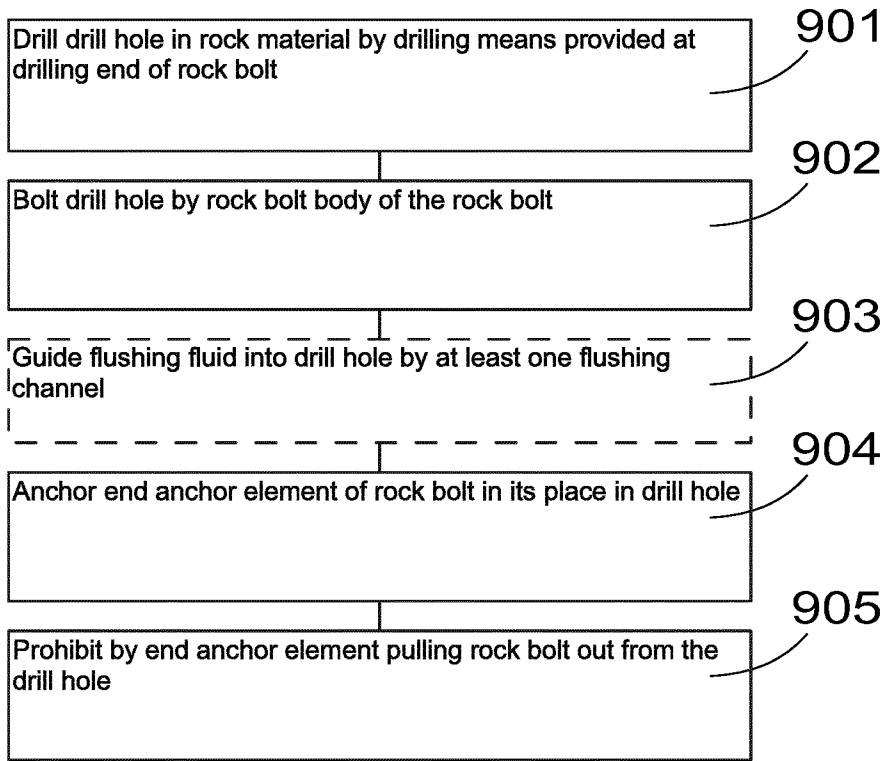

FIG. 9

INTERNATIONAL SEARCH REPORT

International application No
PCT/EP2018/083433

A. CLASSIFICATION OF SUBJECT MATTER
INV. E21D21/00
ADD.

According to International Patent Classification (IPC) or to both national classification and IPC

B. FIELDS SEARCHED
Minimum documentation searched (classification system followed by classification symbols)
E21D

Documentation searched other than minimum documentation to the extent that such documents are included in the fields searched

Electronic data base consulted during the international search (name of data base and, where practicable, search terms used)
EPO-Internal

C. DOCUMENTS CONSIDERED TO BE RELEVANT

Category*	Citation of document, with indication, where appropriate, of the relevant passages	Relevant to claim No.
X	US 2013/121773 A1 (GILMOUR ROYDON JOHN [NZ]) 16 May 2013 (2013-05-16) paragraphs [0001] - [0004], [0018], [0108] - [0158]; figures -----	1-14
X	US 2009/220309 A1 (WEAVER STEVEN [AT] ET AL) 3 September 2009 (2009-09-03) paragraphs [0001] - [0005], [0054] - [0095]; figures -----	1-14

Further documents are listed in the continuation of Box C.

See patent family annex.

* Special categories of cited documents :

- "A" document defining the general state of the art which is not considered to be of particular relevance
- "E" earlier application or patent but published on or after the international filing date
- "L" document which may throw doubts on priority claim(s) or which is cited to establish the publication date of another citation or other special reason (as specified)
- "O" document referring to an oral disclosure, use, exhibition or other means
- "P" document published prior to the international filing date but later than the priority date claimed

- "T" later document published after the international filing date or priority date and not in conflict with the application but cited to understand the principle or theory underlying the invention
- "X" document of particular relevance; the claimed invention cannot be considered novel or cannot be considered to involve an inventive step when the document is taken alone
- "Y" document of particular relevance; the claimed invention cannot be considered to involve an inventive step when the document is combined with one or more other such documents, such combination being obvious to a person skilled in the art
- "&" document member of the same patent family

Date of the actual completion of the international search 3 January 2019	Date of mailing of the international search report 11/01/2019
---	--

Name and mailing address of the ISA/ European Patent Office, P.B. 5818 Patentlaan 2 NL - 2280 HV Rijswijk Tel. (+31-70) 340-2040, Fax: (+31-70) 340-3016	Authorized officer Dekker, Derk
--	--

INTERNATIONAL SEARCH REPORT

Information on patent family members

International application No

PCT/EP2018/083433

Patent document cited in search report	Publication date	Patent family member(s)	Publication date
US 2013121773	A1	16-05-2013	NONE

US 2009220309	A1	03-09-2009	BR PI0618483 A2 30-08-2011
		CA 2624690 A1	18-05-2007
		CN 101305161 A	12-11-2008
		US 2009220309 A1	03-09-2009
		WO 2007053893 A1	18-05-2007
		ZA 200803099 B	27-06-2012
