



- (51) International Patent Classification:
E02F 9/08 (2006.01) *B62D 53/02* (2006.01)
- (21) International Application Number:
PCT/EP2018/065524
- (22) International Filing Date:
12 June 2018 (12.06.2018)
- (25) Filing Language: English
- (26) Publication Language: English
- (71) Applicant: **VOLVO CONSTRUCTION EQUIPMENT AB** [SE/SE]; 631 85 Eskilstuna (SE).
- (72) Inventors: **UNNEBÄCK, Joakim**; Gustafsvägen 23, 633 46 Eskilstuna (SE). **WOODMAN, Andrew**; Rygbjergvej 15, 7183 Randbol (DK).
- (74) Agent: **KRANSELL & WENNBORG KB**; Box 2096, 403 12 Göteborg (SE).
- (81) Designated States (unless otherwise indicated, for every kind of national protection available): AE, AG, AL, AM, AO, AT, AU, AZ, BA, BB, BG, BH, BN, BR, BW, BY, BZ, CA, CH, CL, CN, CO, CR, CU, CZ, DE, DJ, DK, DM, DO, DZ, EC, EE, EG, ES, FI, GB, GD, GE, GH, GM, GT, HN, HR, HU, ID, IL, IN, IR, IS, JO, JP, KE, KG, KH, KN, KP, KR, KW, KZ, LA, LC, LK, LR, LS, LU, LY, MA, MD, ME, MG, MK, MN, MW, MX, MY, MZ, NA, NG, NI, NO, NZ, OM, PA, PE, PG, PH, PL, PT, QA, RO, RS, RU, RW, SA, SC, SD, SE, SG, SK, SL, SM, ST, SV, SY, TH, TJ, TM, TN, TR, TT, TZ, UA, UG, US, UZ, VC, VN, ZA, ZM, ZW.
- (84) Designated States (unless otherwise indicated, for every kind of regional protection available): ARIPO (BW, GH, GM, KE, LR, LS, MW, MZ, NA, RW, SD, SL, ST, SZ, TZ, UG, ZM, ZW), Eurasian (AM, AZ, BY, KG, KZ, RU, TJ,

(54) Title: A WORKING MACHINE

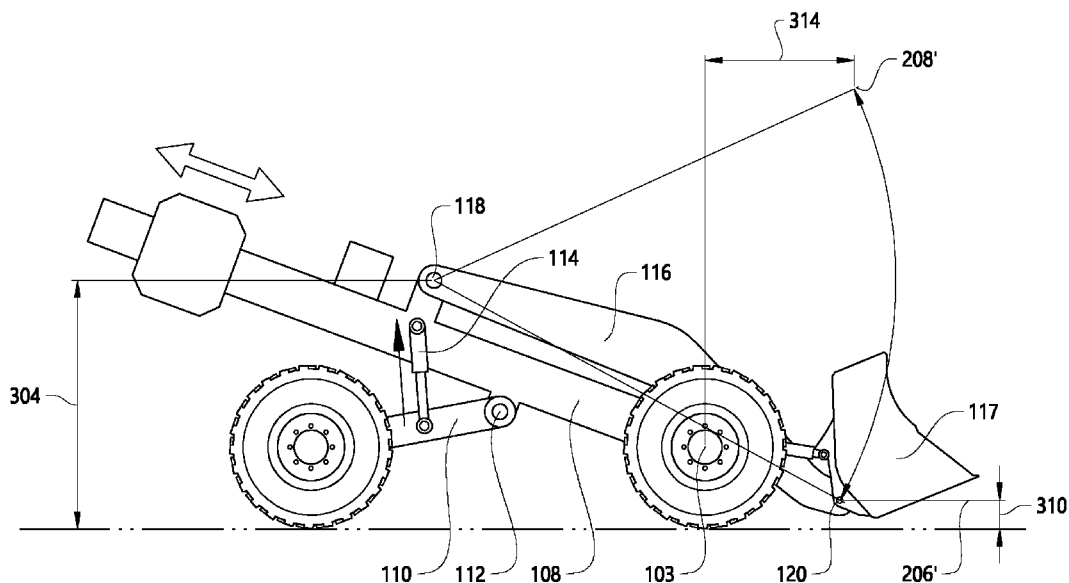

FIG. 3

(57) Abstract: The present invention relates to a working machine (100), comprising a pair of front wheels (102) having a front rotational axis (103), a pair of rear wheels (104) having a rear rotational axis (105), a frame structure (106) comprising a front frame portion (108) connected to the front rotational axis (103), a rear frame portion (110) connected to the rear rotational axis (105), and a pivot joint (112) pivotally connecting the front (108) and rear (110) frame portions to each other around a laterally extending pivot axis, an actuator arrangement (114) connected to the frame structure (106), the actuator arrangement being arranged to control a mutual motion between the front frame portion and the rear frame portion; and a lift arm (116) comprising an inner end portion (118) pivotally connected to the front frame portion (108) at a position between the front and rear wheels, and an outer end portion (120) connectable to an implement at a position in front of the pair of front wheels as seen in the longitudinal direction of the working machine.



TM), European (AL, AT, BE, BG, CH, CY, CZ, DE, DK, EE, ES, FI, FR, GB, GR, HR, HU, IE, IS, IT, LT, LU, LV, MC, MK, MT, NL, NO, PL, PT, RO, RS, SE, SI, SK, SM, TR), OAPI (BF, BJ, CF, CG, CI, CM, GA, GN, GQ, GW, KM, ML, MR, NE, SN, TD, TG).

Published:

— *with international search report (Art. 21(3))*

A WORKING MACHINE

TECHNICAL FIELD

The present invention relates to a working machine. The invention also relates to
5 method for operating such a working machine.

BACKGROUND

Within the field of working machines, the development is continuously increasing to
meet the various demands from the market. For example, the working machines are
10 operated with smart control functions for improving operations at the work site. In
particular, the working machines may communicate with each other for optimizing
operation at the work site.

As the working machines communicate with each other, either directly (V2V
15 communication) or indirectly via a control station, it is possible to be able to operate
the working machines autonomously, i.e. without the use of an operator occupying a
cabin in the working machine. In comparison to a conventional working machine, the
autonomously controlled working machine is thus not in need of a cabin
compartment as there is no operator physically positioned on the machine for
20 controlling the working machine. The cabin compartment is thus more or less
superfluous.

The removal of the cabin compartment will enable for a working machine which is
smaller in size and/or which may utilize the area of the normally arranged cabin
25 compartment for other purposes. Thus, in addition to be able to control the working
machine autonomously, there is a desire to be able to improve various operational
control functions of the working machine for improving the operation of the working
machine.

30 SUMMARY

It is thus an object of the present invention to provide a working machine which is
able to improve at least some of its working operations. This is achieved by a
working machine according to claim 1.

According to a first aspect, there is provided a working machine, comprising a pair of front wheels having a front rotational axis, a pair of rear wheels having a rear rotational axis, a frame structure comprising a front frame portion connected to the front rotational axis, a rear frame portion connected to the rear rotational axis, and a pivot joint pivotally connecting the front and rear frame portions to each other around a laterally extending pivot axis, an actuator arrangement connected to the frame structure, the actuator arrangement being arranged to control a mutual motion between the front frame portion and the rear frame portion; and a lift arm comprising an inner end portion pivotably connected to the front frame portion at a position between the front and rear wheels, and an outer end portion connectable to an implement at a position in front of the pair of front wheels as seen in the longitudinal direction of the working machine.

The wording "front and rear rotational axis" should be construed as relating to either a wheel axle, or to a pair of rotational axes. In the latter case, the working machine may be provided with wheel hub motors on e.g. the respective left and right front wheels. In such case, the left and right front wheels are not connected to each other by a conventional wheel axle. Thus, the front wheels have in such a case a geometric axis around which the wheels rotate. The same applies for the rear wheels. Also, the wording "front" and "rear" should be understood to relate relative measures as seen in the forward driving direction of the working machine. Other alternatives are also conceivable such as an electric motor connected to one or more of the wheel axles, etc.

Furthermore, the wordings "front frame portion" and "rear frame portion" should be construed such that at least a portion of the front frame portion is arranged in front of the rear frame portion as seen in relation to the forward driving direction of the working machine. Thus, and as will be described further below, the front frame portion may have a portion which is located rearwards of the rear frame portion.

Still further, the actuator arrangement may comprise any suitable actuator for controlling the mutual motion between the front and rear frame portions. The actuator arrangement may, for example, be of a hydraulic, pneumatic or electric type. For example, and as will be described below, the actuator arrangement may be a

hydraulic cylinder which is arranged between portions of the front and rear frame portions.

The actuator arrangement and the lift arm may preferably be controlled by means of receiving respective signals from a control unit. The control unit may thus transmit a control signal to the control functions of the actuator arrangement in order to achieve the mutual motion. Also, the control unit may also transmit a control signal to an actuator which is arranged to control the pivotal motion of the lift arm. Separate control units may also be provided for controlling the different functionalities, i.e. the mutual motion of the front and rear frame portions and the pivotal motion of the lift arm.

The control unit may include a microprocessor, microcontroller, programmable digital signal processor or another programmable device. The control unit may also, or instead, include an application specific integrated circuit, a programmable gate array or programmable array logic, a programmable logic device, or a digital signal processor. Where the control unit includes a programmable device such as the microprocessor, microcontroller or programmable digital signal processor mentioned above, the processor may further include computer executable code that controls operation of the programmable device.

The inventors of the present disclosure have realized that by providing a working machine in which the front frame portion is movable in relation to the rear frame portion, the movement pattern of the lift arm may be significantly improved. In particular, depending on the rotational position of the lift arm at the inner end portion, the front frame portion can be moved away from the rear frame portion, or be arranged closer to the rear frame portion. Thus, displacing the front frame portion away from the rear frame portion results in that the inner end portion of the lift arm will be raised. According to an example as will also be described further below, during a digging event, the front frame portion may be displaced from the rear frame portion such that the inner end portion of the lift arm is arranged at a second, elevated position. Hereby, the outer end portion of the lift arm can be further lowered for being able to dig deeper into the pile of soil. Thereafter, when raising the outer end portion, the front frame portion is moved in a direction towards the rear frame portion for lowering the inner end portion of the lift arm to a first, lower position.

Hereby, the movement of the outer end portion of the lift arm will be arranged at a longitudinally closer position relative to the front wheels in comparison to raising the outer end portion when the inner end portion is arranged at the second position. This will improve the stability during such lifting motion.

5

As will also be described further below, the working machine is preferably autonomous. Hereby, the working machine does preferably not contain a cabin compartment. The inner end portion of the lift arm is thus preferably positioned in an area which is normally occupied by such cabin compartment. An advantage is that
10 the outer end portion of the lift arm can be arranged longitudinally closer to the front wheels. Hence, the entire lift arm can be arranged rearwards in comparison to a working machine comprising a cabin compartment. The load distribution from the lift arm and the weight of material at the outer end portion is hereby improved as the inner end portion of the lift arm is arranged closer to the rear wheels in comparison to
15 a conventional working machine provided with a cabin compartment. Hence, a more equal load distribution for the front and rear wheels may be achieved.

According to an example embodiment, the actuator arrangement may be arranged to control the inner end portion of the lift arm between a first position and a second,
20 vertically higher position when moving the front and the rear frame portions relative to each other.

As described above, the inner end portion is in the second position raised in relation to the first position. As the front frame portion is connected to the front rotational axis,
25 the lift arm will move around the front rotational axis. Hereby, when lifting the rear end portion, the lift arm will rotate around the front rotational axis which will lower the front end portion of the lift arm.

Hence, according to an example embodiment, the outer end portion of the lift arm
30 may be controllable between a vertical upper end position and a vertical lower end position by a pivotal motion of the inner end portion of the lift arm, the vertical lower end position being provided at a lower vertical distance from ground level when the inner end portion assumes the second position compared to when the inner end portion assumes the first position.

35

An advantage is, as described above, that an implement connected to the outer end portion of the lift arm is able to approach e.g. a pile of soil closer to ground level, thus improving the digging functionalities.

5 It should be readily understood that the second position may not necessarily be located straight above the first position. For example, the second position can also be arranged in front of the first position as seen in the longitudinal direction of the working machine.

10 According to an example embodiment, the front rotational axis and rear rotational axis may move toward each other by a rotation of the pivot joint when moving the inner end portion of the lift arm between the first and second positions.

According to an example embodiment, the front frame portion may be pivotably
15 connected to the front rotational axis and the rear frame portion may be pivotably connected to the rear rotational axis. The pivotal connection enables for improved movement between the front and rear frame portions. Hence, when the inner end portion of the lift arm is raised from the first position to the second position, the front and rear wheels move towards each other whereby a front end of the front frame
20 portion rotates around the front rotational axis, and a rear end of the rear rotational axis rotates around the rear rotational axis.

According to an example embodiment, the actuator arrangement may be an actuator
25 cylinder arranged move at least portions of the front and rear frame portions away from each other when moving the inner end portion of the lift arm from the first position to the second position. The actuator cylinder is preferably hydraulically controlled, although pneumatics may function as well. The wording "away from each other" should be construed as being in at least a vertical direction of the working machine.

30

According to an example embodiment, at least a portion of the front frame portion may be arranged vertically above at least a portion of the rear frame portion. Hereby, the front frame portion extends from the front rotational axis and to a position rearward the pivotal connection between the front and rear frame portions.

35

According to an example embodiment, the actuator arrangement may be connected between the portion of the front frame portion and the portion of the rear frame portion. The actuator arrangement thus “pushes” the front frame portion in at least a vertical direction above the rear frame portion.

5

According to an example embodiment, the working machine may further comprise a counterweight arrangement connected to the front frame portion. A counterweight is beneficial as it will improve the stability of the working machine during its various operations.

10

According to an example embodiment, the front frame portion may extend from the front rotational axis and in a direction rearward of the front rotational axis, wherein the counterweight is movable along at least a portion of the extension of the front frame portion.

15

Hereby, the counterweight is operable to be control dependently on the current position of e.g. the lift arm or an operation mode of the working machine, which will be described further below in relation to the description of the second aspect.

20

According to an example embodiment, the working machine may be an autonomously operated working machine. The working machine is preferably an autonomously operated loader vehicle.

25

The autonomously controlled working machine may be controlled by the above described control unit. It may also be controlled remotely by an operator.

30

According to a second aspect, there is provided a method for controlling a working machine, the working machine comprising a frame structure comprising a front frame structure connected to a front rotational axis of the working machine, a rear frame structure connected to a rear rotational axis of the working machine, wherein the front and rear frame structures are connected to each other at pivot joint allowing a mutual rotation around a laterally extending pivot axis, the working machine further comprising a lift arm comprising an inner end portion pivotably connected to the front frame portion at a position between the front and rear rotational axes, and an outer end portion connected to an implement at a position in front of the front rotational

35

axis as seen in the longitudinal direction of the working machine, the method comprising the steps of determining that the working machine is entering a pile of material for loading of the implement; controlling the implement to be arranged in a vertically lower end position; moving the inner end portion of the lift arm from a first
5 position to a second, vertically higher position by controlling a rotation around the laterally extending pivot axis; determining that the implement has entered the pile of material; moving the inner end portion of the lift arm from the second position towards the first position; and moving the implement from the vertically lower end position towards a vertical upper end position.

10

As described above in relation to the first aspect, when positioning the inner end portion of the lift arm in the second position, the implement will be even further lowered. The advantage is thus that the implement can enter the pile of material at a position closer to the ground, whereby filling of material into the implement will be
15 improved.

The step of determining that the working machine enters the pile of material may be determined by e.g. a control function or control means. Such control means may e.g. be a camera, GPS, LIDAR, etc. Other alternatives are also conceivable, such as a
20 control function determining that the implement is empty and arranged at a relatively low position close to the ground. A load sensor may be used for determining that the implement is empty. A speed sensor may also be used, whereby it can be determined that the working machine enters the pile of material based on a detected speed or deceleration level of the working machine.

25

Moreover, the working machine may determine to have entered the pile of material by means of e.g. a load sensor determining that the implement is exposed to an increased load, or that an increased propulsive power is needed for operating the working machine forwards. Other alternatives are also conceivable such as e.g. a
30 camera or distance sensor keeping track of the distance between the implement and the pile of material.

According to an example embodiment, the method may further comprise the steps of determining if the working machine is leaving the pile of material; and moving the

inner end portion of the lift arm to the first position if the working machine is leaving the pile of material.

5 Hereby, the movement of the implement towards the vertical upper end position will be made longitudinally closer the front wheels in comparison to lifting the implement when the inner end portion of the lift arm in the second position.

10 According to an example embodiment, the method may further comprise the steps of determining if the working machine is approaching an unloading station; moving the inner end portion of the lift arm to the second position; and releasing the material at the unloading station when the working machine arrives at the unloading station.

15 Raising the inner end portion of the lift arm when the outer end portion is arranged a distance above ground will arrange the outer end portion at an increased longitudinal distance from the front wheels. Hereby, the outer end portion of the lift arm will increase its coverage for being able to properly reach the unloading station. The unloading station may e.g. be a loading platform of a truck, etc.

20 According to an example embodiment, the working machine may comprise a counterweight arrangement connected to the front frame portion, the counterweight arrangement being movable between an inner and an outer portion of the front frame portion, wherein the inner portion is located in front of the outer portion as seen in the longitudinal direction of the working machine.

25 According to an example embodiment, the method may further comprise the step of positioning the counterweight arrangement at the inner portion when moving the inner end portion of the lift arm to the first position and operating the working machine with an empty implement.

30 An advantage is that the front wheels will be exposed to an increased pressure which will improve the grip between the front wheels and the ground.

According to an example embodiment, the method may further comprise the step of positioning the counterweight arrangement at the outer portion before releasing the

material at the unloading station. Hereby, improved stability is achieved when unloading having the implement at a relatively high vertical position above ground.

Further effects and features of the second aspect are largely analogous to those
5 described above in relation to the description of the first aspect.

Further features of, and advantages with, the present invention will become apparent when studying the appended claims and the following description. The skilled person will realize that different features of the present invention may be combined to create
10 embodiments other than those described in the following, without departing from the scope of the present invention.

BRIEF DESCRIPTION OF THE DRAWINGS

The above, as well as additional objects, features and advantages of the present
15 invention, will be better understood through the following illustrative and non-limiting detailed description of exemplary embodiments of the present invention, wherein:

Fig. 1 is a perspective view schematically illustrating a working machine according to an example embodiment;
20

Fig. 2 is a side view of the working machine in Fig. 1 when arranging the front and rear frame portions close to each other; according to an example embodiment

Fig. 3 is a side view of the working machine Fig. 1 when the front and rear frame
25 portions are displaced from each other; according to an example embodiment, and

Fig. 4 is a flow chart illustrating a method for controlling the working machine according to an example embodiment.

30 DETAILED DESCRIPTION OF EXAMPLE EMBODIMENTS OF THE INVENTION

The present invention will now be described more fully hereinafter with reference to the accompanying drawings, in which exemplary embodiments of the invention are shown. The invention may, however, be embodied in many different forms and should not be construed as limited to the embodiments set forth herein; rather, these

embodiments are provided for thoroughness and completeness. Like reference character refer to like elements throughout the description.

With particular reference to Fig. 1, which is a perspective view schematically illustrating a working machine 100 according to an example embodiment. The working machine 100 comprises a pair of front wheels 102 and a pair of rear wheels 104. The front wheels 102 are connected to a front rotational axis 103 and the rear wheels 104 are connected to a rear rotational axis 105. The front and rear rotational axes are in Fig. 1 depicted as a respective front and rear wheel axle. However, the working machine may be operated by wheel hub motors, and in such a case no physical wheel axles may be present. The working machine can thus be operated by wheel hub motors or by other types of prime movers, such as an ICE, an electric machine, etc. Steering of the working machine may, for example, be controlled by so-called Ackermann steering, either on both of the front 102 and rear 104 wheels, or solely on the rear wheels 104.

The working machine 100 further comprises a frame structure 106 supporting various components, etc. In detail, the frame structure 106 comprises a front frame portion 108 and a rear frame portion 110. The front 108 and rear 110 frame portions are pivotally connected to each other at a pivot joint 112. Thus, the pivot joint 112 allows a mutual rotation between the front 108 and rear 110 frame portions. Moreover, the front frame portion 108 is pivotably connected to the front rotational axis 103 and the rear frame portion 110 is pivotably connected to the rear rotational axis 105. As can be seen in Fig. 1, the front frame portion 108 extends from the front rotational axis 103 and in a direction rearward of the working machine 100. In the example depicted in Fig. 1, the front frame portion 108 extends from the front rotational axis 103 to a rear end 109 located rearwards of the pivot joint 112. In the example of Fig. 1, the rear end 109 is located at a longitudinal position rearward of the rear rotational axis 105.

Moreover, the working machine 100 comprises a lift arm 116 connected to an implement 117 at an outer end portion 120 of the lift arm 116. The lift arm 116 is pivotably connected to the front frame portion 108 of the frame structure at an inner end portion 118 of the lift arm 116. In detail, the lift arm 116 is connected to the front frame portion 108 at a lift arm pivot joint 119. The lift arm pivot joint 119 is preferably

arranged at a longitudinal position between the front 103 and rear 105 rotational axes. The lift arm 116 is thus raised and lowered by a pivotal motion at the lift arm pivot joint 119. This motion is preferably achieved by using a lift cylinder (not shown). The lift motion of the lift arm is illustrated in further detail in Figs. 2 and 3, and also
5 described below. The implement 117, which in Fig. 1 is exemplified in the form of a bucket, can also be tilted in relation to the lift arm, preferably by using a tilt cylinder 202.

As is further depicted in Fig. 1, the working machine 100 comprises an actuator
10 arrangement 114. The actuator arrangement 114, in Fig. 1 exemplified as a hydraulic cylinder, is arranged to provide a mutual motion between the front frame portion 108 and the rear frame portion 110. The actuator arrangement 114 is, as depicted in Fig. 1, preferably connected between a portion 122 of the rear frame portion 110 and a portion 124 of the front frame 108. The portion 124 of the front frame 108 is thus
15 arranged above the rear frame portion 110. Hereby, when the actuator arrangement 114 is extended, the portion 124 of the front frame 108 is raised in relation to the rear frame structure 110, i.e. the front 108 and rear 110 frame portions move away from each other. When, on the other hand, the actuator arrangement 114 is retracted, the portion 124 of the front frame 108 is lowered in relation to the rear frame structure
20 110, i.e. the front 108 and rear 110 frame portions move closer to each other. As the lift arm pivot joint 119 is arranged on the front frame portion 108 at a location longitudinally rearward of the pivot joint 112, the inner end portion 118 of the lift arm 116 will be raised when extending the actuator arrangement 114.

25 Furthermore, the working machine 100 also comprises a control unit 126 which is connected to various parts of the working machine 100. The control unit 126 is particularly arranged to control the motion of the actuator arrangement 114. The control unit 126 may also be arranged to control lifting and lowering of the lift arm, tilting of the implement, as well as driving operation of the working machine 100. The
30 working machine 100 is thus preferably an autonomously operated working machine 100. The autonomously operated working machine may be controlled by operation of the control unit, or remotely controlled whereby the control unit receives control signals for driving the working machine in various directions.

Moreover, the working machine 100 comprises a counterweight 130 connected to the front frame portion 108 at a position rearward of the pivot joint 112. The counterweight 130 is movable along a portion of the front frame portion 108 in order to controllably compensate for different load conditions. Different examples of
5 operation of the counterweight will be given below.

In order to describe the functionality of the working machine in Fig. 1, reference is made to Figs. 2 – 4. With initial reference to Fig. 2, which is a side view of the working machine in Fig. 1 when arranging the front 108 and rear 110 frame portions
10 close to each other. In detail, the actuator arrangement 114 is arranged in a fully retracted position. Hereby, the inner end portion 118 of the lift arm 116 is arranged at a first, lower position 204 above ground level. As also depicted in Fig. 2, the outer end portion 120 of the lift arm 116 is controllable between a vertical lower end position 206 and vertical upper end position 208 by means of the pivotal motion at
15 the inner end portion 118. When the outer end portion 120 is arranged at the vertical lower end position 206, the outer end portion 120 is arranged at a vertical distance 210 from ground level 212, and when the outer end portion 120 is arranged at the vertical upper end position 208, the outer end portion 120 is arranged at a higher vertical distance 215 from the ground level 212. Furthermore, when the outer end
20 portion 120 is arranged at the vertical upper end position 208, the outer end portion 120 is arranged at a first longitudinal distance 214 from the front rotational axis 103.

Reference is now made to Fig. 3 which is a side view of the working machine Fig. 1 when the front and rear frame portions are displaced from each other. As can be
25 seen, the front 108 and rear 110 frame portions are moved in relation to each other in comparison to the relative position depicted in Fig. 2. In detail, the actuator arrangement 114 is extended in relation to the illustration in Fig. 2. Hereby, the front 108 and rear 110 frame portions rotate relative to each other around the pivot joint 112. The front 103 and rear 105 rotational axes are thus moved towards each other.
30 The inner end portion 118 of the lift arm 116 is hereby raised to a second, vertically higher position 304 above ground level. Thus, the second position 304 is higher above ground level compared to the first position 204. Moreover, the outer end portion 120 of the lift arm 116 is maintained in the lower end position 206.

When rotating the front 108 and rear 110 frame portions relative to each other, the front frame portion 108 also rotates around the front rotational axis 103. As the inner end portion 118 of the lift arm 116 is connected to the front frame portion 108 a distance behind the front rotational axis 103, the lift arm 116 will rotate around the front rotational axis 103 when raising the inner end portion to the second position 304. Hereby, the outer end portion 120 of the lift arm is arranged at a vertical lower end position 206' which is located closer to ground level in comparison to the position depicted in Fig. 2. In detail, the outer end portion 120 of the lift arm is located at a lower vertical distance 310 from ground level in comparison to the vertical distance 210 from ground level depicted in Fig. 2. When e.g. entering a pile of soil, the implement 117 is able to dig further into the pile.

When raising the lift arm 116 while keeping the inner end portion 118 of the lift arm 116 in the second, vertically higher position, the outer end portion 120 of the lift arm 116 will be arranged at a vertical upper end position 208' located at a second longitudinal distance 314 from the front rotational axis 103. The second longitudinal distance 314 is larger than the first longitudinal distance 214.

Based on the above description, it may thus be beneficial to arrange the inner end portion 118 of the lift arm 116 in the second, vertically higher position 304 when entering a material to be dug from the ground. It may thereafter be beneficial to lower the inner end portion 118 to the first position 204 depicted in Fig. 2, for providing the implement 117 closer to the front rotational axis 103 during lifting of the implement 117. Also, when moving the inner end portion 118 from the second position to the first position, the implement will be raised which is beneficial as the need of raising the implement using e.g. hydraulics is not needed.

Reference is therefore made to Fig. 4 is a flow chart illustrating a method for controlling the working machine according to an example embodiment. Firstly, after initiating operation, it is determined S1 that the working machine 100 is entering a pile of material for loading the implement. This can be determined in a number of different manners, such as by sensors or cameras, etc. It may also be determined by solely detecting that the working machine is moving with an empty implement 117. It can hereby be assumed that the working machine is on its way to a pile of material for loading. The implement 117 is controlled S2 to be arranged in a vertically lower

end position 206. This is achieved by rotation of the inner end portion 118 of the lift arm 116 around the lift arm pivot joint 119. Thereafter, before digging, the inner end portion 118 of the lift arm is moved S3 from the first position 204 depicted in Fig. 2 to the second position 304 depicted in Fig. 3. Hereby, and as described above, the
5 implement will be arranged at lower vertical distance 310 from ground level.

The digging operation can now be initiated and the control unit 126 can determine S4 that the implement 117 has entered the pile of material. This is preferably made by receiving a signal indicating that an increased torque for driving the working
10 machine forwards is necessary. The inner end portion 118 of the lift arm 116 is thereafter moved S5 to the first position 204 as is depicted in Fig. 2, whereby the implement 117 is moved S6 vertical upper end position 208. The inner end portion 118 is preferably moved to the first position 204 when it is determined that the working machine is leaving the pile of material, i.e. when the digging operation is
15 completed.

The working machine 100 is thereafter typically driven towards an unloading station for unloading the material in the implement. When arriving at the unloading station, the inner end portion 118 can preferably be arranged at the second position depicted
20 in Fig. 3. Hereby, the implement is arranged at the second longitudinal distance 314 from the front rotational axis 103 when arranged at the upper end position 208'. The implement 117 can hereby reach further away from the front wheels 102.

Preferably, when operating the working machine 100 with an empty implement, the
25 counterweight is positioned at an inner end portion of the front frame portion 108. When on the other releasing material at the unloading station, the counterweight should preferably be positioned at an outer end position of the front frame portion 108.

30 It is to be understood that the present invention is not limited to the embodiments described above and illustrated in the drawings; rather, the skilled person will recognize that many changes and modifications may be made within the scope of the appended claims.

CLAIMS

1. A working machine (100), comprising
 - a pair of front wheels (102) having a front rotational axis (103),
 - a pair of rear wheels (104) having a rear rotational axis (105),
 - 5 - a frame structure (106) comprising a front frame portion (108) connected to the front rotational axis (103), a rear frame portion (110) connected to the rear rotational axis (105), and a pivot joint (112) pivotally connecting the front (108) and rear (110) frame portions to each other around a laterally extending pivot axis,
 - an actuator arrangement (114) connected to the frame structure (106), the actuator
 - 10 arrangement being arranged to control a mutual motion between the front frame portion and the rear frame portion; and
 - a lift arm (116) comprising an inner end portion (118) pivotably connected to the front frame portion (108) at a position between the front and rear wheels, and an outer end portion (120) connectable to an implement at a position in front of the pair
 - 15 of front wheels as seen in the longitudinal direction of the working machine.

2. The working machine according to claim 1, wherein the actuator arrangement is arranged to control the inner end portion (118) of the lift arm between a first position (204) and a second, vertically higher position (304) when moving the front and the
- 20 rear frame portions relative to each other.

3. The working machine according to claim 2, wherein the outer end portion (120) of the lift arm is controllable between a vertical upper end position (208) and a vertical lower end position (206) by a pivotal motion of the inner end portion (118) of the lift
- 25 arm, the vertical lower end position (206) being provided at a lower vertical distance (310) from ground level (212) when the inner end portion (118) assumes the second position (304) compared to when the inner end portion (118) assumes the first position (204).

- 30 4. The working machine according to any one of claims 2 or 3, wherein the front rotational axis and rear rotational axis move toward each other by a rotation of the pivot joint when moving the inner end portion of the lift arm between the first and second positions.

5. The working machine according to any one of the preceding claims, wherein the front frame portion is pivotably connected to the front rotational axis and the rear frame portion is pivotably connected to the rear rotational axis.
- 5 6. The working machine according to claim 2, wherein the actuator arrangement is an actuator cylinder arranged move at least portions of the front and rear frame portions away from each other when moving the inner end portion of the lift arm from the first position to the second position.
- 10 7. The working machine according to any one of the preceding claims, wherein at least a portion of the front frame portion is arranged vertically above at least a portion of the rear frame portion.
8. The working machine according to claim 7, wherein the actuator arrangement is
15 connected between the portion of the front frame portion and the portion of the rear frame portion.
9. The working machine according to any one of the preceding claims, further
20 comprising a counterweight arrangement (130) connected to the front frame portion.
10. The working machine according to claim 9, wherein the front frame portion extends from the front rotational axis and in a direction rearwards of the front rotational axis, the counterweight being movable along at least a portion of the extension of the front frame portion.
- 25 11. The working machine according to any one of the preceding claims, wherein the working machine is an autonomously operated working machine.
12. A method for controlling a working machine, the working machine comprising a
30 frame structure comprising a front frame structure connected to a front rotational axis of the working machine, a rear frame structure connected to a rear rotational axis of the working machine, wherein the front and rear frame structures are connected to each other at pivot joint allowing a mutual rotation around a laterally extending pivot axis, the working machine further comprising a lift arm comprising an inner end
35 portion pivotably connected to the front frame portion at a position between the front

and rear rotational axes, and an outer end portion connected to an implement at a position in front of the front rotational axis as seen in the longitudinal direction of the working machine, the method comprising the steps of:

- 5 - determining (S1) that the working machine is entering a pile of material for loading of the implement;
- controlling (S2) the implement to be arranged in a vertically lower end position;
- moving (S3) the inner end portion of the lift arm from a first position to a second, vertically higher position by controlling a rotation around the laterally extending pivot axis;
- 10 - determining (S4) that the implement has entered the pile of material;
- moving (S5) the inner end portion of the lift arm from the second position towards the first position; and
- moving (S6) the implement from the vertically lower end position towards a vertical upper end position.

15

13. The method according to claim 12, further comprising the steps of:

- determining if the working machine is leaving the pile of material; and
- moving the inner end portion of the lift arm to the first position if the working machine is leaving the pile of material.

20

14. The method according to any one of claims 12 and 13, further comprising the steps of:

- determining if the working machine is approaching an unloading station;
- moving the inner end portion of the lift arm to the second position; and
- 25 - releasing the material at the unloading station when the working machine arrives at the unloading station.

15. The method according to any one of claims 12 – 14, wherein the working machine comprises a counterweight arrangement connected to the front frame portion, the counterweight arrangement being movable between an inner and an outer portion of the front frame portion, wherein the inner portion is located in front of the outer portion as seen in the longitudinal direction of the working machine.

16. The method according to claim 15, further comprising the step of:

- positioning the counterweight arrangement at the inner portion when moving the inner end portion of the lift arm to the first position and operating the working machine with an empty implement.

5 17. The method according to any one of claim 15 when dependent on claim 14, further comprising the step of:

- positioning the counterweight arrangement at the outer portion before releasing the material at the unloading station.

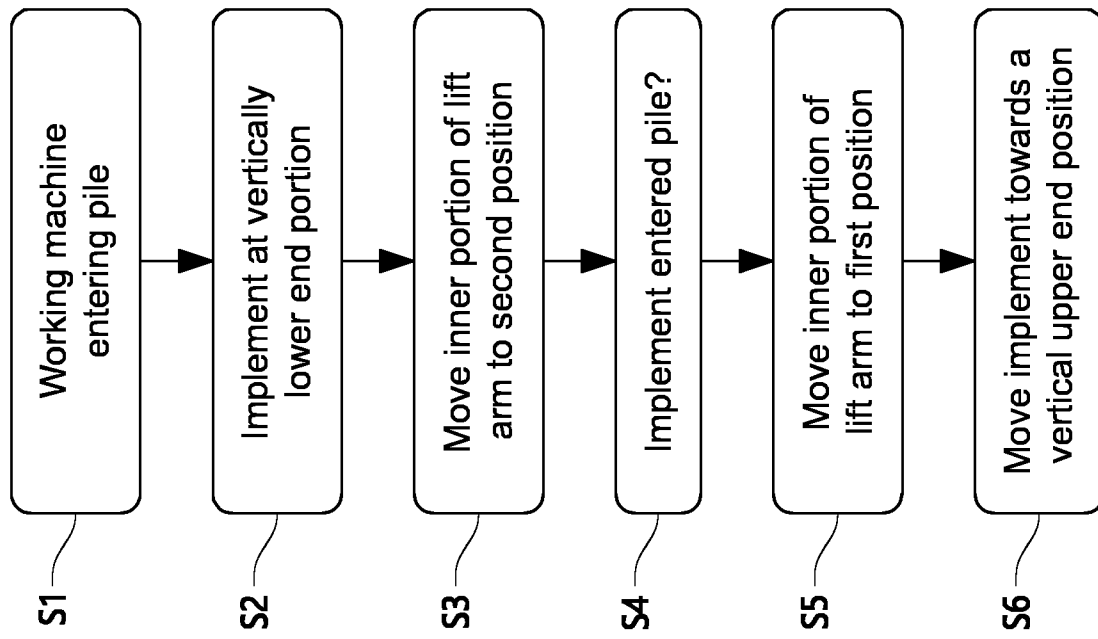

FIG. 4

INTERNATIONAL SEARCH REPORT

International application No
PCT/EP2018/065524

A. CLASSIFICATION OF SUBJECT MATTER
 INV. E02F9/08 B62D53/02
 ADD.
 According to International Patent Classification (IPC) or to both national classification and IPC

B. FIELDS SEARCHED
 Minimum documentation searched (classification system followed by classification symbols)
 E02F B62D B60N B60G
 Documentation searched other than minimum documentation to the extent that such documents are included in the fields searched

Electronic data base consulted during the international search (name of data base and, where practicable, search terms used)
 EPO-Internal, WPI Data

C. DOCUMENTS CONSIDERED TO BE RELEVANT

Category*	Citation of document, with indication, where appropriate, of the relevant passages	Relevant to claim No.
X A	EP 0 012 095 A1 (GIBERT PIERRE JEAN MARIE) 11 June 1980 (1980-06-11) the whole document	1,5,7,11 2-4,6, 8-10, 12-17
A	----- GB 1 233 622 A (POCLAIN) 26 May 1971 (1971-05-26) the whole document	1-17
A	----- DE 24 54 021 A1 (HEINE FRANZ DIPL ING) 26 May 1976 (1976-05-26) claim 1; figure 1 -----	1-17

Further documents are listed in the continuation of Box C.

See patent family annex.

* Special categories of cited documents :

- "A" document defining the general state of the art which is not considered to be of particular relevance
- "E" earlier application or patent but published on or after the international filing date
- "L" document which may throw doubts on priority claim(s) or which is cited to establish the publication date of another citation or other special reason (as specified)
- "O" document referring to an oral disclosure, use, exhibition or other means
- "P" document published prior to the international filing date but later than the priority date claimed

- "T" later document published after the international filing date or priority date and not in conflict with the application but cited to understand the principle or theory underlying the invention
- "X" document of particular relevance; the claimed invention cannot be considered novel or cannot be considered to involve an inventive step when the document is taken alone
- "Y" document of particular relevance; the claimed invention cannot be considered to involve an inventive step when the document is combined with one or more other such documents, such combination being obvious to a person skilled in the art
- "&" document member of the same patent family

Date of the actual completion of the international search 29 January 2019	Date of mailing of the international search report 12/02/2019
---	---

Name and mailing address of the ISA/ European Patent Office, P.B. 5818 Patentlaan 2 NL - 2280 HV Rijswijk Tel. (+31-70) 340-2040, Fax: (+31-70) 340-3016	Authorized officer Clarke, Alister
--	--

INTERNATIONAL SEARCH REPORT

Information on patent family members

International application No

PCT/EP2018/065524

Patent document cited in search report	Publication date	Patent family member(s)	Publication date
EP 0012095	A1	11-06-1980	DE 2962401 D1 06-05-1982
			EP 0012095 A1 11-06-1980
			FR 2442170 A1 20-06-1980

GB 1233622	A	26-05-1971	BE 770528 Q 01-12-1971
			DE 1907164 A1 23-10-1969
			ES 363596 A1 01-01-1971
			FR 1584249 A 19-12-1969
			GB 1233622 A 26-05-1971

DE 2454021	A1	26-05-1976	NONE
