



US00D749703S

(12) **United States Design Patent**
Otaka et al.

(10) **Patent No.:** **US D749,703 S**

(45) **Date of Patent:** **** Feb. 16, 2016**

(54) **HIGH PRESSURE FUEL INJECTION PIPE**

FOREIGN PATENT DOCUMENTS

(71) Applicant: **USUI Kokusai Sangyo Kaisha Limited,**
Shizuoka (JP)

JP 806537 3/1981
JP 1360807 6/2009

(Continued)

(72) Inventors: **Mitsumasa Otaka,** Shizuoka (JP);
Toshiyuki Omura, Shizuoka (JP);
Nobuo Kato, Shizuoka (JP)

OTHER PUBLICATIONS

Diesel Technical Society, Title: High Pressure Fuel Lines, Dec. 9,
2007, pp. 1-2.

(73) Assignee: **USUI KOKUSAI SASNGYO KAISHA**
LIMITED, Shizuoko (JP)

(Continued)

(**) Term: **14 Years**

Primary Examiner — Mark Goodwin

(21) Appl. No.: **29/495,958**

(74) *Attorney, Agent, or Firm* — Sutherland Asbill &
Brennan LLP

(22) Filed: **Jul. 8, 2014**

(30) **Foreign Application Priority Data**

Jan. 24, 2014 (JP) 2014-1265

(51) **LOC (10) Cl.** **23-01**

(52) **U.S. Cl.**
USPC **D23/259; D15/5**

(58) **Field of Classification Search**

USPC D15/5, 28; D8/382, 387; D24/129;
D23/259-269; D13/155; 138/109, 44,
138/177, 178; 123/468; 285/386, 197, 354,
285/332, 332.1-332.4, 58, 83; 72/370.11
CPC . F02M 2200/315; F02M 55/02; F02M 55/00;
F02M 55/025; F02M 55/005; F02M 63/00;
F16L 19/02; F16L 19/028; F16L 19/0225;
F16L 19/025; F16L 9/00; F16L 23/00; F16L
27/00; F16L 58/08; F16L 58/02; F02B 3/06;
F02B 3/00

See application file for complete search history.

(56) **References Cited**

U.S. PATENT DOCUMENTS

2,432,946 A 12/1947 Jean
D241,881 S 10/1976 Peterson et al.

(Continued)

(57) **CLAIM**

The ornamental design for a high pressure fuel injection pipe,
as shown and described.

DESCRIPTION

FIG. 1 is a front view of a high pressure fuel injection pipe
showing our new design;
FIG. 2 is a top view thereof;
FIG. 3 is a right side view thereof;
FIG. 4 is a left side view thereof;
FIG. 5 is an enlarged view along line 1-1 of FIG. 1;
FIG. 6 is a cross-sectional view along line 2-2 of FIG. 2;
FIG. 7 is an enlarged view along line 6-6 of FIG. 6;
FIG. 8 is an enlarged view of FIG. 4; and,
FIG. 9 is a cross-sectional view showing our high pressure
fuel injection pipe in use.

The broken line showings in FIGS. 1-4, 6, 8, and 9 are for the
purpose of illustrating portions of the high pressure fuel injection
pipe and form no part of the claimed design. The broken line
showing of a mating component in FIG. 9 is for the
purpose of illustrating the usage environment of the high
pressure fuel injection pipe and forms no part of the claimed
design.

1 Claim, 5 Drawing Sheets

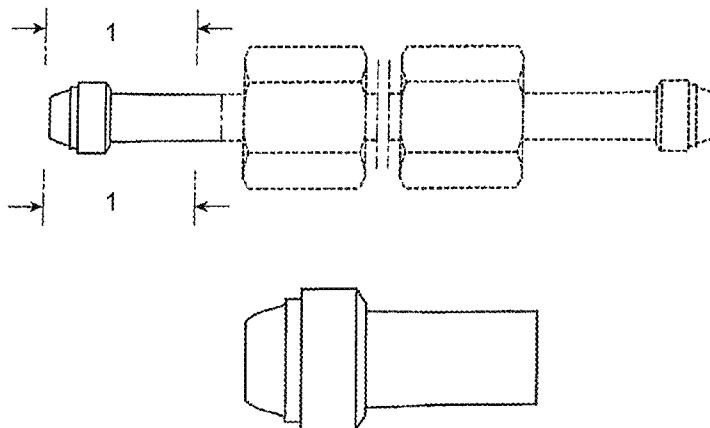

(56)

References Cited

U.S. PATENT DOCUMENTS

4,134,430 A 1/1979 Mukasa et al.
 4,266,577 A 5/1981 Usui
 4,665,876 A * 5/1987 Hashimoto F16L 19/025
 123/468
 5,109,888 A 5/1992 Usui
 5,402,829 A 4/1995 Takikawa et al.
 5,667,255 A * 9/1997 Kato F02M 55/005
 285/133.4
 D388,876 S 1/1998 Sampson
 5,853,203 A 12/1998 Crandall
 6,070,618 A 6/2000 Iwabuchi
 6,286,556 B1 * 9/2001 Kato F02M 55/02
 138/109
 6,415,768 B1 7/2002 Usui
 6,431,608 B1 * 8/2002 Kato F02M 55/002
 285/13
 6,536,806 B1 * 3/2003 Uematsu F16L 58/08
 285/55
 6,824,173 B2 * 11/2004 Usui F02M 55/005
 285/334.1
 6,840,283 B2 1/2005 Furugen et al.
 6,843,275 B2 1/2005 Kato
 D503,799 S 4/2005 Beck
 D503,978 S 4/2005 Beck
 6,902,210 B1 * 6/2005 Rowley F16L 47/04
 285/334.2
 6,935,377 B2 8/2005 Furugen
 7,213,576 B2 5/2007 Furugen
 D576,154 S 9/2008 Ledbetter et al.

D625,817 S 10/2010 Rinner
 D626,230 S 10/2010 Rinner
 D634,005 S 3/2011 Beck
 D635,664 S 4/2011 Beck
 D649,240 S 11/2011 Lewis et al.
 8,186,724 B2 * 5/2012 Kato F02M 55/005
 285/247
 D701,304 S 3/2014 Lair et al.
 D716,915 S * 11/2014 Seino D23/259
 D730,495 S * 5/2015 Umehara D23/262
 D731,626 S * 6/2015 Umehara D23/262
 2003/0230349 A1 12/2003 Furugen et al.
 2005/0005913 A1 1/2005 Usui et al.
 2005/0127665 A1 * 6/2005 Usui F02M 55/025
 285/197
 2005/0279327 A1 12/2005 Morita
 2006/0163873 A1 * 7/2006 Langhuber F02M 55/005
 285/386

FOREIGN PATENT DOCUMENTS

JP 1360808 6/2009
 JP 1361187 6/2009
 JP 1361188 6/2009
 KR 3001636020000 5/1995

OTHER PUBLICATIONS

ssimsol.com, Title: Fuel Injection Pipe, Feb. 28, 2011, Google.com, p. 1.

* cited by examiner

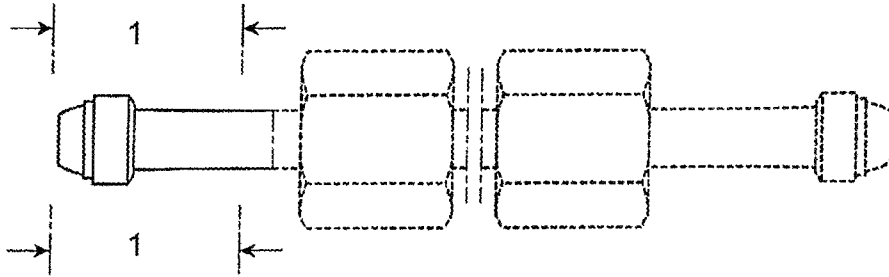

FIG. 1

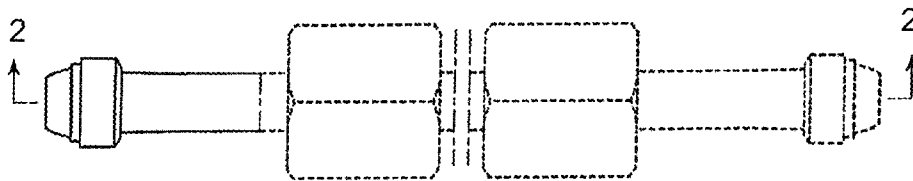

FIG. 2



FIG. 3



FIG. 4

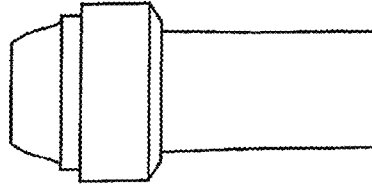

FIG. 5

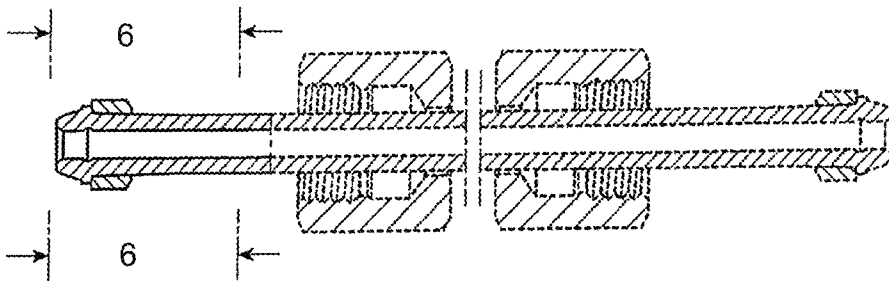

FIG. 6

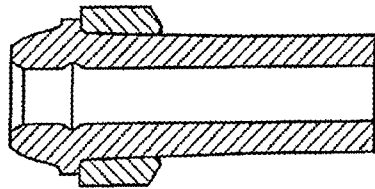

FIG. 7

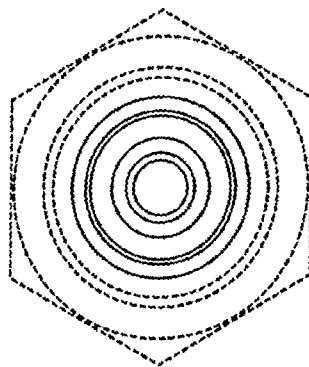

FIG. 8

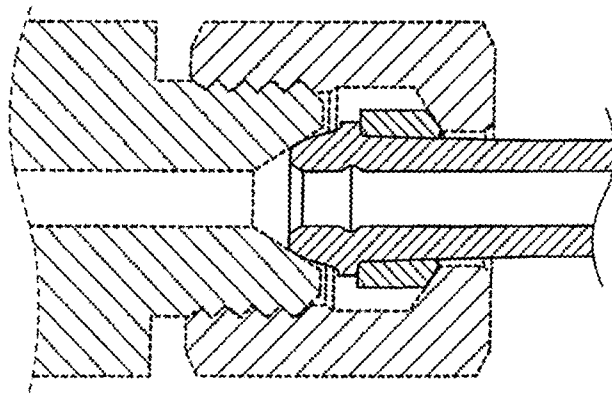

FIG. 9