

(No Model.)

2 Sheets—Sheet 1.

P. FRIEDERICH.
DEVICE FOR LOADING OR UNLOADING CATTLE.

No. 492,002.

Patented Feb. 21, 1893.

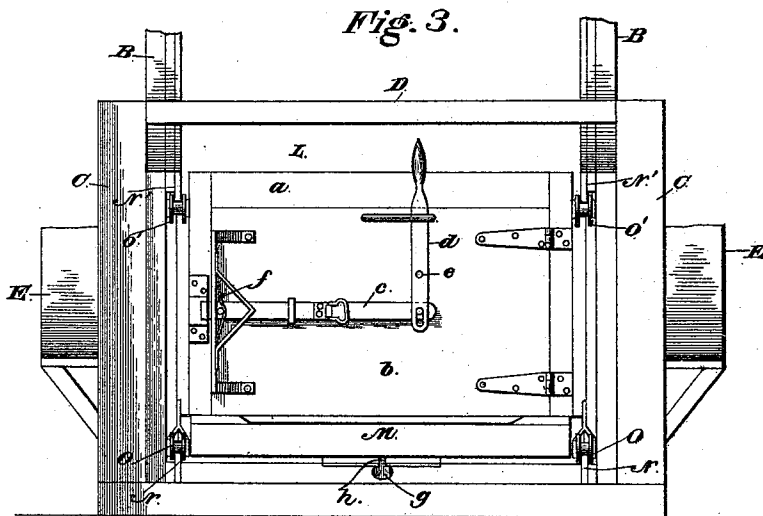
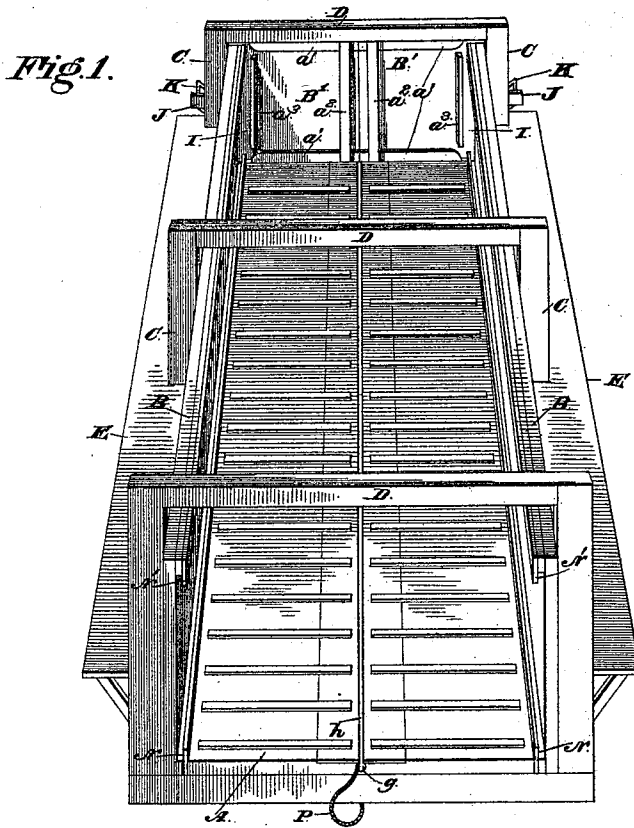

Witnesses

M. S. Sawyer
F. R. Harding

Inventor

Philippe Friederich

By his Attorneys,

C. Snow & Co.

P. FRIEDERICH.

DEVICE FOR LOADING OR UNLOADING CATTLE.

No. 492,002.

Patented Feb. 21, 1893.

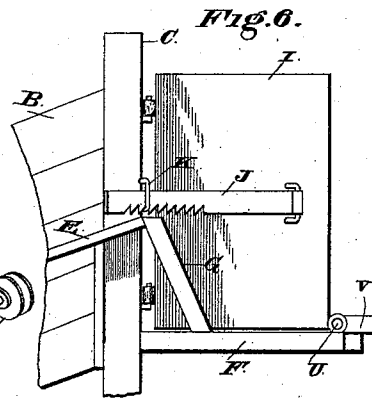
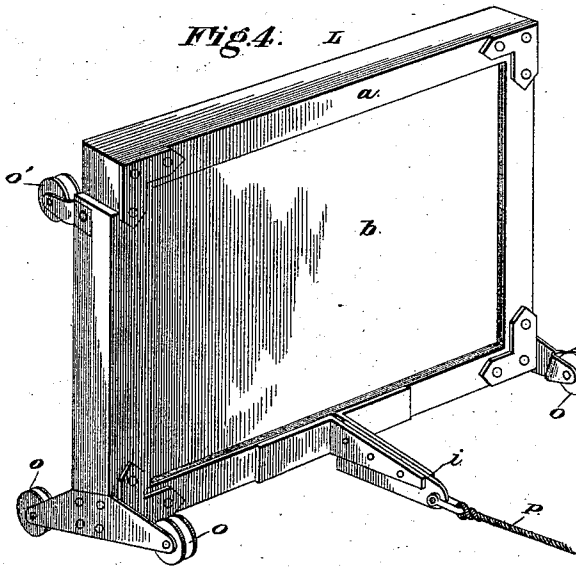
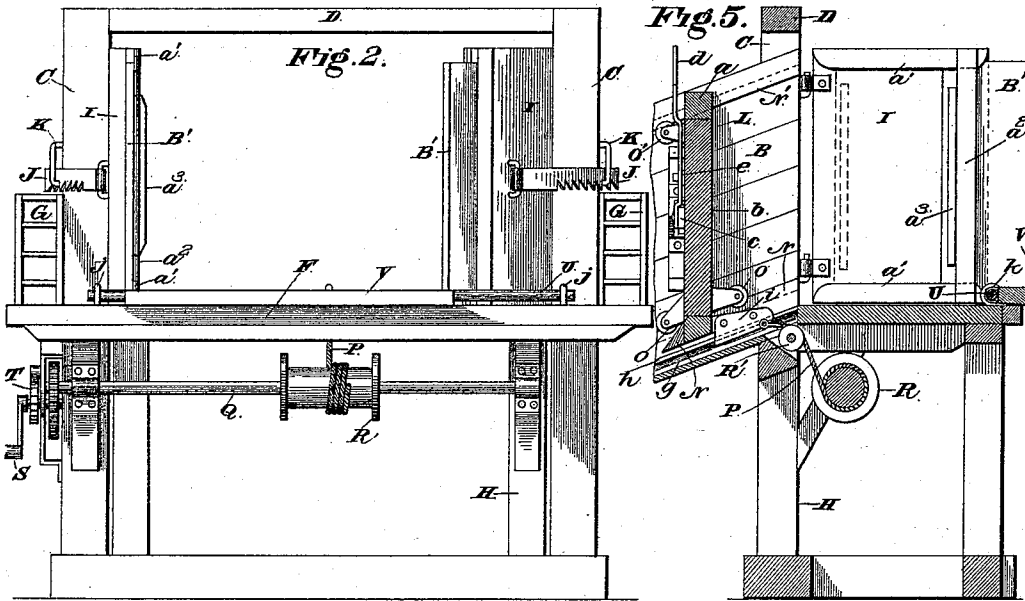

Witnesses

M. Fowler
F. R. Harding

Inventor

Philippe Friederich

By his Attorneys,

C. Snow & Co.

UNITED STATES PATENT OFFICE.

PHILIPPE FRIEDERICH, OF LANGLEY, KANSAS.

DEVICE FOR LOADING OR UNLOADING CATTLE.

SPECIFICATION forming part of Letters Patent No. 492,002, dated February 21, 1893.

Application filed June 17, 1892. Serial No. 437,062. (No model.)

To all whom it may concern:

Be it known that I, PHILIPPE FRIEDERICH, a citizen of the United States, residing at Langley, in the county of Ellsworth and State of Kansas, have invented a new and useful Device for Loading and Unloading Cattle, of which the following is a specification.

My invention relates to a new and improved device for loading and unloading stock, and in particular is designed to fulfill the requirements and necessities experienced in shipping cattle in stock-cars and unloading them from the same.

My invention has for its particular object to prevent the necessity of the presence and work of an attendant within the inclosed drive or gang-way, thus precluding any injury to him by the cattle; again, to provide a device for the aforesaid purpose wherein the cattle can be gradually forced and guided along in the desired direction by certain means under the control of the operator; furthermore to furnish auxiliary arrangements so that the gang-way can be laterally adjusted to be coincident with the doorway of the car; to arrange the doors of the drive-way so they can be set at any angle; and finally to render the device as a whole, strong, convenient, labor-saving, cheap, and of great commercial utility in its allotted function.

For attainment of these several objects my invention consists in certain details of construction, arrangement and combination of parts, all of which will be more fully described hereinafter, and the specific points of novelty in which will be pointed out in the appended claims.

Referring to the accompanying drawings forming a part of this specification:—Figure 1 is a perspective view of the interior of the drive-way. Fig. 2 is a rear elevation of Fig. 1. Fig. 3 is a front elevation of Figs. 1 and 2. Fig. 4 is a detail perspective view of one of the doors and its adjusting means. Fig. 5 is a detail view showing the longitudinally moving gate and its operating cord. Fig. 6 is a detail view with parts broken away and illustrating my improved adjustable gang-plank or crossing.

Like letters of reference indicate like parts in all the figures of the drawings.

Referring particularly to Figs. 1, 2, and 3, A

indicates an inclined gang-way made of strong planking and provided with a series of raised transverse strips spaced on each side of its central line, as shown, serving to insure the footing of the cattle going up or down the gang-way which is supported by cross-beams underneath, the latter being held in an inclined plane by uprights of a framework or foundation of any ordinary or approved construction such as that shown.

BB are the side walls of the drive-way, of requisite height to prevent escape of animals and bolted or otherwise secured to the vertical side-beams or uprights CC which strengthen and support the same and are tied and braced at their tops by cross-beams DD fastened there across.

Parallel and co-extensive with the incline of the gang-way A and on each side thereof outside of a side wall B, is a running plank E, fastened securely to the uprights CC and communicating at the front with the supplementary or front platform F by the stairway G; the platform F being horizontal as shown and upheld rigidly by the underneath base or framework H, of usual and obvious construction.

II designate respectively the doors at the upper end of the drive-way suitably hinged thereto and capable of adjustment by means of the toothed or serrated metallic bar J loosely secured to the door at one end and engaging the catch K on the upright C; the teeth of said bar J being so inclined as to permit them to slide idly over the catch when the door is being shut but will engage and hold in any set position in the opposite direction, thus enabling the doors to be used as rigid extensions of the side walls of the drive-way when loading cattle off the platform F into a stock-car. On the inside of each door I I and between the transverse braces a' a' is placed the extensible panel or extension B', designed to be slipped out in line with the plane of the door and limited by the vertical strip a^2 engaging a stop-projection a^3 on the panel B' to act as an extended guard or protection to the platform as the cattle pass there-
over.

L represents a longitudinally sliding or rolling wall or partition comprising the vertically placed rectangular frame, a , and the hinged

solid door, *b* arranged to open rearwardly and outwardly, and provided with a spring actuated latch-bar or catch-lever *c* loosely pivoted at its rear end to the vertical hand-lever, *d*, which in turn is pivoted at *e* to the door and when operated opens the door by withdrawing the latch-bar *c*; the spring *f* serving to normally press the latch-bar *c* in a forward direction. Thus it will be seen that the door, *b*, can be opened by the hand-lever, *c*, from the outside of the drive-way on either side of one of the running planks *E E*. An inclined or beveled strip *M* is secured to the sill across the bottom of the door sill for the apparent purpose of a bridge or means of entrance or exit for the incoming or outgoing cattle. This wall or partition *L* is designed to follow along in the rear of the cattle and thereby push and urge them forward up the gang-way into the car, and to this end, is made longitudinally movable on the lateral bottom and top guide-ways, *N N'* by the rollers, *O O'* affixed suitably on each side of the door, respectively, at the bottom and top to engage their respective guide-rails *NN'* which latter are held in proper position on the side of the walls (see Figs. 2 and 3) of the drive-way by any ordinary fastening device, such as shown. By this arrangement the partition *L* is free to be moved up and down the way, the operator at the end controlling said longitudinal movement by the rope *P* and the windlass or spool *R* mounted underneath the platform *F* upon the rotatable shaft *Q* having the crank-arm *S* for winding up the rope, and the pawl and ratchet device *T* shown on the end thereof to prevent the slip of the rope.

The bottom *A* of the drive-way is provided with a central longitudinal curved or hollowed-out recess merging into communication with the exterior through the narrow slot, *h*, and designed to receive the end of the plate, *z*, secured to the bottom of the partition *L* and depending through the slot, *h*, into the recess *g*, where it is attached to the operating rope *P* which extends up through said recess over the pulley *R'* to the windlass *R*. Accordingly it is clear that by operating the windlass the partition *L* can be pulled up the inclined way, the rollers *O O'* engaging rails *NN'* and the plate *i* following through the slot *h*.

On the front of the platform *F* is secured a transverse rod *U*, held in a slightly raised position by the fastening eye-bolts *j j*, and having the bridge or gang-way *V* made capable of lateral movement thereupon by the sliding loops or clips *k k*, so that the gang-way can be placed directly in front of the door of the car alongside, if the same should happen

not to be exactly co-incident with the drive-way.

The use and operation of the several devices composing my invention will be obvious. The cattle being driven in the guide-way, through the door of the partition *L*, the said door being closed, and the upper doors *I I* with their extensions *B'* being set in position as guards and extensions the operator can gradually force and urge the cattle up the incline by turning the windlass and bringing the rolling partition *L* upon its guiding rails against the rear animals, thus urging them on up until they are forced out upon the platform *F* and through the doorway of the car opposite; the gang-way *V* having been properly adjusted.

All the parts of my improvement are strong, durable, and interchangeable, and can be applied to existing forms of cattle chutes: moreover, this device is to be in portable form so that it can be transferred to places of use with ease and celerity.

Having described my invention, what I claim is—

1. In a cattle driveway, the combination with a gangway having opposite side walls and provided with a central longitudinally-disposed groove extending from end to end of the gangway, of a partition supported for movement upon the gangway a plate secured to the bottom of the partition and extending into the groove, a winding mechanism located under the gangway, and a rope connected to the plate and mounted for movement in the said groove, said rope being passed over one end of the gangway and connected with the winding-mechanism, substantially as specified.

2. In a cattle driveway, the combination with the gangway having opposite side walls provided with tracks, said gangway provided with a central longitudinally-disposed recess or slot extending throughout the length thereof, of a partition provided at its corners with wheels for loosely engaging the tracks, a winding mechanism located under the gangway, and a rope connected to the partition and mounted for movement in the slot said rope being passed over the end of the gang-way and connected with the winding mechanism, substantially as specified.

In testimony that I claim the foregoing as my own I have hereto affixed my signature in the presence of two witnesses.

PHILIPPE FRIEDERICH.

Witnesses:

THEODORE JURY,
JOSEPH BYRNE.