

(19) **DANMARK**

(10) **DK/EP 3592973 T3**



(12) **Oversættelse af  
europæisk patentskrift**

Patent- og  
Varemærkestyrelsen

- 
- (51) Int.Cl.: **F 03 D 13/10 (2016.01)** **B 66 C 1/10 (2006.01)** **B 66 C 13/06 (2006.01)**
- (45) Oversættelsen bekendtgjort den: **2023-08-28**
- (80) Dato for Den Europæiske Patentmyndigheds bekendtgørelse om meddelelse af patentet: **2023-07-26**
- (86) Europæisk ansøgning nr.: **17837862.6**
- (86) Europæisk indleveringsdag: **2017-12-08**
- (87) Den europæiske ansøgnings publiceringsdag: **2020-01-15**
- (86) International ansøgning nr.: **EP2017082061**
- (87) Internationalt publikationsnr.: **WO2018192675**
- (30) Prioritet: **2017-04-18 DE 102017206527**
- (84) Designerede stater: **AL AT BE BG CH CY CZ DE DK EE ES FI FR GB GR HR HU IE IS IT LI LT LU LV MC MK MT NL NO PL PT RO RS SE SI SK SM TR**
- (73) Patenthaver: **Siemens Gamesa Renewable Energy A/S, Borupvej 16, 7330 Brande, Danmark**
- (72) Opfinder: **Mastrup, Aage, Kroghedevej 1, 6971 Spjald, Danmark**  
**QUIST, Niclas Damgaard, Gl. Slotsvej 15, 5500 Middelfart, Danmark**  
**LARSEN, Hans Rico, Hjøllundvej 3, 7361 Ejstrupholm, Danmark**
- (74) Fuldmægtig i Danmark: **Novagraaf Brevets, Bâtiment O2, 2 rue Sarah Bernhardt CS90017, F-92665 Asnières-sur-Seine cedex, Frankrig**
- (54) Benævnelse: **FREM GANGSMÅDE TIL MONTERING AF KOMPONENTER TIL EN VINDMØLLE OG LØFTEARRANGEMENT**
- (56) Fremdragne publikationer:  
**CN-A- 105 604 790**  
**DE-A1-102013 219 279**  
**JP-A- 2015 101 413**  
**JP-A- 2016 210 607**  
**KR-A- 20150 102 518**  
**KR-A- 20160 006 561**



# DESCRIPTION

**[0001]** The invention relates to a method for installing components of a wind turbine, with a lifting device for lifting the respective component hanging at the lifting device via at least one cable.

**[0002]** Some prior art is disclosed in KR 2015 0102518 A, JP 2016 210607 A, JP 2015 101413 A, and DE 2009847.

**[0003]** Building a wind turbine involves the installation of several separate components which usually need to be lifted by means of a lifting device like a crane. For building the tower several separate tower segments are to be lifted and stacked above one another. After building the tower the nacelle with the gear box and other preinstalled parts of the drive train needs to be installed. Finally the generator and the hub are installed and respective rotor blades are fixed to the hub.

**[0004]** All components, especially the larger ones are lifted by means of the lifting device during installation or when being uninstalled due to maintenance or replacement.

**[0005]** A problem arises, when the respective component hanging at the lifting device via one or several cables starts to swing or vibrate or rotate due to external forces, usually wind.

**[0006]** These vibrations bear problems especially when the respective component is positioned to be fixed to another, already installed components. A usual technique is to attach cables or ropes at the component, which are hand held by several workers for stabilizing the component, while it is positioned by means of the lifting device and the interaction of the workers. This way of stabilizing or controlling the movement of wind turbine components during their installation is very effortful for the workers trying to control or stabilize a movement and can provide a control only to a certain extent. This unsatisfying when strong forces like strong winds impact on the component.

**[0007]** It is therefore an object of the invention to provide an improved method for installing components for a wind turbine with a better stabilization of the component against vibrations and rotations.

**[0008]** For solving the above-mentioned problem the invention proposes that at least one stabilization device is stabilizing the components against movements induced by external forces by means of a gyroscopic effect.

**[0009]** According to the invention a stabilization device is provided at the lifting arrangement in the region which can start to swing or vibrate or rotate due to external forces acting on the component hanging at the lifting device. This stabilization device is able to automatically stabilize the component against vibrations, rotations or any kind of movement due to a certain

extent by means of a gyroscopic effect. This stabilization device is activated when the lifting device starts to lift the component. As soon as the component starts to swing or move in a direction different to the moving direction effected by the lifting device the stabilization device starts to provide counterforces in reaction of the external forces acting on the component. These counterforces are created by means of a gyroscopic effect. The stabilization device is a gyroscopic stabilization or damping device.

**[0010]** By means of these counterforces created by the gyroscopic working principle of the gyroscopic stabilisation device the overall forces acting on the component are widely reduced, so that any kind of movement or vibration is widely reduced to a very small extent or is completely reduced.

**[0011]** This provides the advantage that during the lifting process the component does not move or swing in an uncontrolled way. Especially when the component is positioned to be attached to previously installed components no specific stabilization action needs to be performed by the workers as it is necessary in the prior art by means of the hand held ropes. As the stabilization is performed by the stabilization device the workers are solely responsible for the precise orientation of the component to the previously installed component, if this cannot be done solely by the lifting device. The stabilization device (gyroscope) can also be remote controlled by a worker or operator to precisely orientate and position the component. This could also be done automatically by means of an automatic control unit which controls the stabilization device to hold the component in a present direction or orientation.

**[0012]** The stabilization itself is provided by means of a rotating flywheel which is tilted by means of a tilting device around at least one axis with a perpendicular orientation to the axis of rotation of the flywheel. The stabilization device, which can also be called a control moment gyroscope, comprises the rotating flywheel which is enclosed in a rigid casing. The flywheel spins at speeds up several hundred kilometres per hour around its centre axis. A tilting device which tilts the casing around at least one axis perpendicular to the central rotation axis of the flywheel tilts the casing and the flywheel for changing the momentum created by the flywheel, which tilting action results in the counterforce. This control moment or control force, which can also be named as a gyroscopic resistance force, has a certain direction and extinguishes the external force acting on the component. This gyroscopic stabilization device is designed to produce high moments or reaction forces which can counter or extinguish the external forces to a high extent or preferably completely.

**[0013]** Furthermore, it is advantageous to provide a sensor device which provides measurement values regarding the force induced movements like vibrations or rotations with the stabilization device being controlled based on the measurement values. The sensor device can be part of or attached to the stabilization device in a region which is not moved by the tilting device, as the sensor device is used for measuring any kind of vibrations or swinging or rotating movement.

**[0014]** The stabilization device is attached to a bunch of cables connecting a fixation means of

the lifting device to a handling tool such that the stabilizing device is attached between the fixation means and the handling tool.

**[0015]** The component is for example a rotor blade, a nacelle, a hub, a tower section, a generator or a gear box, with this enumeration is not conclusive.

**[0016]** The invention furthermore relates to a lifting arrangement for lifting components during the installation of a wind turbine, comprising a lifting device and a component attached to the lifting device via at least one cable, wherein at least one stabilization device is provided for stabilizing the component against movements induced by external forces by means of a gyroscopic effect.

**[0017]** The stabilization device comprises a rotating flywheel and a tilting device for tilting the flywheel around at least one axis with a perpendicular orientation to the axis of rotation of the flywheel. It is certainly possible that the rotating flywheel, which is encased in a closed casing, can be tilted also around a second axis, which is also perpendicular to the axis of rotation of the flywheel, so that in total three axis being perpendicular to each other are provided. The stabilization device gyroscope can also be called a control moment gyroscope.

**[0018]** In a further embodiment of the invention a sensor device is provided for providing measurement values regarding the force induced movements like vibrations or rotations with the stabilization device being controlled based on the measurement values.

**[0019]** The stabilization device of the inventive lifting device is attached to a bunch of cables connecting a fixation means of the lifting device to a handling tool such that the stabilizing device is attached between the fixation means and the handling tool.

**[0020]** The component being lifted by means of the lifting device is a rotor blade, a nacelle, a hub, a tower section, a generator or a gear box.

**[0021]** The above and other aspects, features and other advantages of the present invention will be more clearly understood from the following details description and the accompanying drawings, which show schematically:

Fig. 1

a lifting arrangement,

Fig. 2

a part of a lifting arrangement with a stabilization device attached to a handling tool handling a rotor blade,

Fig. 3

the arrangement of Fig. 2 with the stabilization device being attached to a fixation tool, with a rotor blade being attached to the handling tool,

Fig. 4

an arrangement with the stabilization device being directly attached to a nacelle fixed to

a handling tool,

Fig. 5

the arrangement of Fig. 4 with the stabilization device being attached to a bunch of cables connecting the handling tool to a fixation means of the lifting device,

Fig. 6

the arrangement of Fig. 4 with the stabilization device being attached to the handling tool,

Fig. 7

an arrangement with the stabilization device being attached to a handling tool fixed to a tower section,

Fig. 8

an arrangement with the stabilization device being attached to a hub, and

Fig. 9

an arrangement with the fixation device being directly attached to a complete rotor.

**[0022]** Fig. 1 shows a non-claimed lifting arrangement 1 comprising a lifting device 2, here a crane 3. The lifting device 2 comprises at least one lifting cable 4, to which a fixation means 5, here a hook 6, is attached. The hook 6 is connected via further cables 7 to a fixation tool 8. This fixation tool is for example a fixation frame or a fixation yoke, to which via further cables 9 a handling tool 10 is attached. The handling tool 10, also for example a handling frame or handling yoke, is connected to a component 11, for example a nacelle 12 comprising a hub 13, which shall be installed to a tower installation 14 being built from several tower segments 15 stacked above one another. These tower segments 15 have also been lifted and installed by means of the lifting arrangement 1.

**[0023]** The lifting arrangement 1 further comprises a stabilization device 16, which is used for stabilizing the component 11 respectively the complete system comprising all items hanging at the hook 6 against movements like or vibrations or rotations due to external forces, especially strong wind forces acting on the component 11.

**[0024]** The stabilization device creates forces or moments which are able to counter or extinguish the external forces inducing the movement like vibrations or rotations, and thus the movement itself.

**[0025]** The stabilization device comprises a flywheel rotating at high speed around a central axis. A tilting device can tilt the casing in which the rotating flywheel is arranged around at least one axis, which axis is perpendicular to the axis of rotation of the flywheel. It is possible that the tilting device can tilt the casing also around a second axis, which is itself perpendicular to the first tilting axis and the rotation axis, thus three axes being perpendicular to each other are provided.

**[0026]** Due to the high speed rotation of the flywheel and the tilting movement reaction

moment or reaction forces are created which counteract the external forces acting on the component 11 respectively the moving system.

**[0027]** This stabilization enables a very stable, non-swinging and non-rotating lifting and positioning action of the component 11 relative to a previously installed component, to which the component 11 shall be attached.

**[0028]** Fig. 2 shows a first example of a part of a non-claimed lifting arrangement 1. It shows the component 11 in form of a rotor blade 17 being firmly attached to a handling tool 10. The handling tool 10 is attached via cables 9 to a fixation tool 8, which is attached by means of cables 7 to the hook 6.

**[0029]** The gyroscopic stabilization device 16, which can also be called a control moment gyroscope, is in this example attached to the handling tool 10. It is firmly secured to the handling tool 10, so that any gyroscopic reaction or resistance force resulting from the flywheel movement and the tilting action act directly on the handling tool 10 for stabilizing its movement and thus the complete movement of the whole swinging or rotating system.

**[0030]** Fig. 3 shows an arrangement according to Fig. 1, with the same setup. In this embodiment the gyroscope, i.e. the stabilization device 16, is attached to a bunch of cables 7, which are also part of the swinging system. A stabilization can also be performed when directing the gyroscopic resistance forces into the cable arrangement.

**[0031]** Fig. 4 shows a part of a non-claimed lifting arrangement 1, comprising the hook 6 with cables 7 connecting the hook 6 to a handling tool 10. Firmly attached to the handling tool 10 is the component 11, here the nacelle 12.

**[0032]** The gyroscopic stabilization device 16 is directly attached to the nacelle 12, here for example at an upper part of the nacelle 12. It is obvious that the stabilization device can be arranged also in other parts of the nacelle 12, as long as it is firmly attached to the nacelle 12, so that the reaction or resistance forces can directly act on the nacelle 12 for stabilizing any kind of movement.

**[0033]** Fig. 5 shows another embodiment of a partially shown lifting arrangement 1. The setup corresponds to the setup shown in Fig. 4. In this embodiment the gyroscopic stabilization means 16 is again attached to the bunch of cables 7 connecting the hook 6 to the handling tool 10. It is attached somewhere between the hook 6 and the handling tool 10. Its resistance or reaction forces act on the bunch of cables 7 and thus stabilize the whole swinging or rotating system.

**[0034]** Fig. 6 shows another embodiment of a lifting arrangement 1 shown only in part. The setup corresponds to a setup shown in Figs. 4 and 5. In this embodiment the gyroscopic device 16 is directly attached to the handling tool 10. It is obvious that the stabilization device 16, which is firmly attached to the handling tool 10 can be positioned at various locations at the

handling tool 10.

**[0035]** Fig. 7 shows a further embodiment of a non-claimed lifting arrangement 1, which is shown only in part. The figure shows the hook 6 and the cables 7 connecting the hook 6 to a handling tool 10. The handling tool 10 is attached to a tower segment 15, which shall be installed either on the bottom at a respective foundation or which shall be attached to a previously installed tower segment 15.

**[0036]** The gyroscopic stabilization device 16 is attached to the frame-like handling tool 10 for stabilizing the system.

**[0037]** It is to be noted, that it is also possible to attach the stabilization device 16 to the tower segment 15, if there are respective means at the tower segment 15 to which the stabilization device 16 can be firmly attached. Especially when the tower segment 15 is the lowest or bottom segment, which usually comprises a bottom, the stabilization device 16 can be directly attached to the bottom of this bottom segment 15.

**[0038]** Fig. 8 shows another embodiment with the component 11 hanging at the hook being a hub 13. The gyroscopic stabilization device 16 is mounted directly on the hub 13.

**[0039]** Finally Fig. 9 shows an embodiment of a lifting arrangement 1, which is again shown only in part. The component 11 which shall be lifted is a complete rotor 18 comprising three rotor blades 17 being attached to the hub 13. The hub 13 and thus the complete rotor 18 is attached to the lifting device 2 via a cable 7 connecting it, for example, directly to the hook 6.

**[0040]** The gyroscopic stabilization device 16 is directly attached to the hub 13 stabilizes any unwanted movement of the component 11 respectively the rotor 18.

**[0041]** While not shown, the stabilization device 16 comprises at least one sensor means which senses any kind of movement or vibration or rotation of the respective component or the swinging or rotating system, which vibration or rotation needs to be stabilized or counteracted. Based on the sensor measurement the stabilization device 16 is controlled by means of a respective controlling device, which especially controls the tilting action and thus the counter or resistance forces produced for countering or extinguishing the respective unwanted vibrations or rotations.

**[0042]** Although the present invention has been described in detail with reference to the preferred embodiment, the present invention is not limited by the disclosed examples from which the skilled person is able to derive other variations without departing from the scope of the invention as defined by the appended claims.

## **REFERENCES CITED IN THE DESCRIPTION**

Cited references

This list of references cited by the applicant is for the reader's convenience only. It does not form part of the European patent document. Even though great care has been taken in compiling the references, errors or omissions cannot be excluded and the EPO disclaims all liability in this regard.

**Patent documents cited in the description**

- [KR20150102518A \[0002\]](#)
- [JP2016210607A \[0002\]](#)
- [JP2015101413A \[0002\]](#)
- [DE2009847 \[0002\]](#)

## PATENTKRAV

1. Fremgangsmåde til montering af komponenter (11) til en vindmølle ved hjælp af en løfteindretning (2) til opløftning af den pågældende komponent (11), der via mindst ét kabel (4, 7, 9) hænger i løfteindretningen (2),

5 hvor mindst én stabiliseringsindretning (16) ved hjælp af en gyroskopvirkning stabiliserer komponenten (11) mod bevægelser, der fremkaldes af eksterne kræfter, hvor stabiliseringsindretningen (16) er fastgjort til et bundt kabler (7), der forbinder et fikseringsmiddel (5) af løfteindretningen (2) med et håndteringsværktøj (10), således at stabiliseringsindretningen (16) er fastgjort  
10 mellem fikseringsmidlet (5) og håndteringsværktøjet (10); hvor

stabiliseringen tilvejebringes ved hjælp af et roterende svinghjul, der ved hjælp af en vippeindretning er vippet omkring mindst én akse med en vinkelret orientering i forhold til svinghjulets rotationsakse.

2. Fremgangsmåde ifølge krav 1, **kendetegnet ved, at** en sensorindretning  
15 tilvejebringer måleværdier vedrørende de kraftfremkaldte bevægelser, idet stabiliseringsindretningen (16) styres på basis af måleværdierne.

3. Fremgangsmåde ifølge et hvilket som helst af de foregående krav,

**kendetegnet ved, at** komponenten (11) er et rotorblad (17), en nacelle (12), et nav (13), en tårnsektion (15), en generator eller en gearkasse.

20 4. Løftearrangement til opløftning af komponenter under installeringen af en vindmølle, hvilket arrangement omfatter en løfteindretning (2) og en komponent (11), der via mindst ét kabel (4, 7, 9) er fastgjort til løfteindretningen (2),

hvor mindst én stabiliseringsindretning (16) er beregnet til stabilisering af komponenten (11) mod bevægelser, der fremkaldes af eksterne kræfter, hvor  
25 stabiliseringsindretningen (16) er fastgjort til et bundt kabler (7), der forbinder et fikseringsmiddel (5) af løfteindretningen (2) med et håndteringsværktøj (10), således at stabiliseringsindretningen (16) er fastgjort mellem fikseringsmidlet (5) og håndteringsværktøjet (10);

hvor stabiliseringsindretningen (16) omfatter et roterende svinghjul og en vippeindretning til vipning af svinghjulet omkring mindst én akse med en vinkelret orientering i forhold til svinghjulets rotationsakse; og

hvor komponenten (11) er et rotorblad (17), en nacelle (12), et nav (13),  
5 en tårnsektion (15), en generator eller en gearkasse.

5. Løftearrangement ifølge krav 4, **kendetegnet ved, at** en sensorindretning er beregnet til tilvejebringelse af måleværdier vedrørende de kraftfremkaldte bevægelser, idet stabiliseringsindretningen (16) styres på basis af måleværdierne.

# DRAWINGS

FIG 1

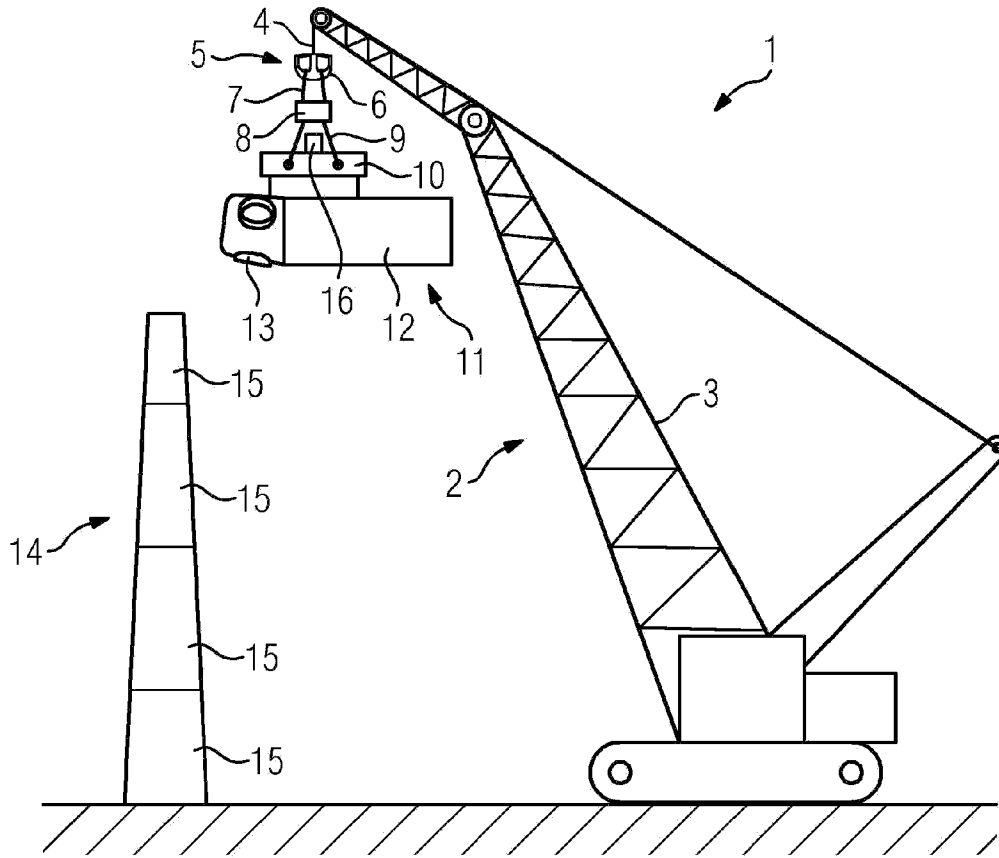

FIG 2

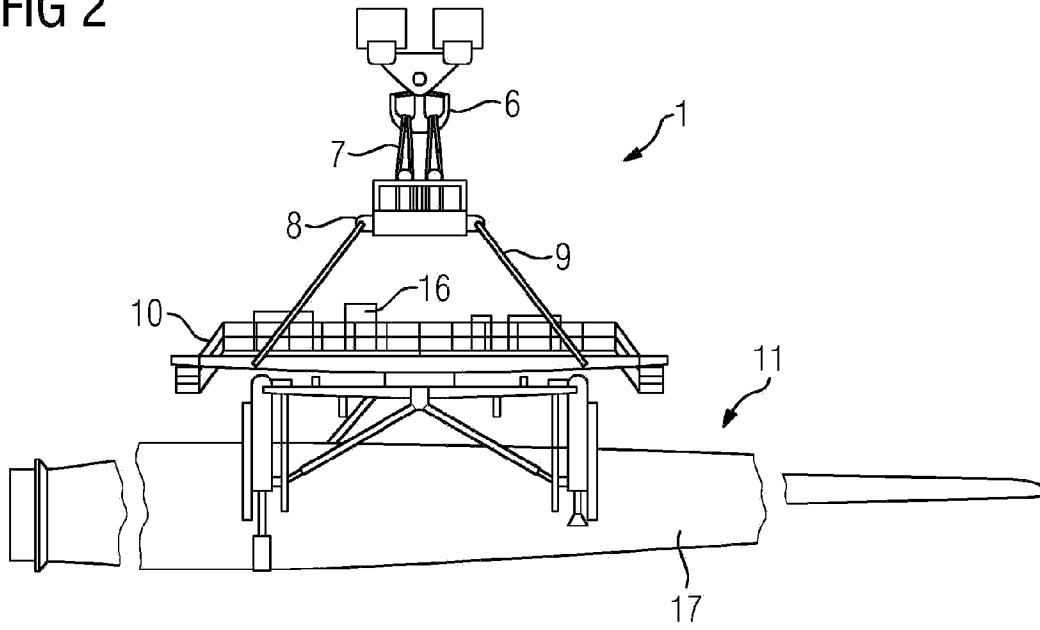

FIG 3

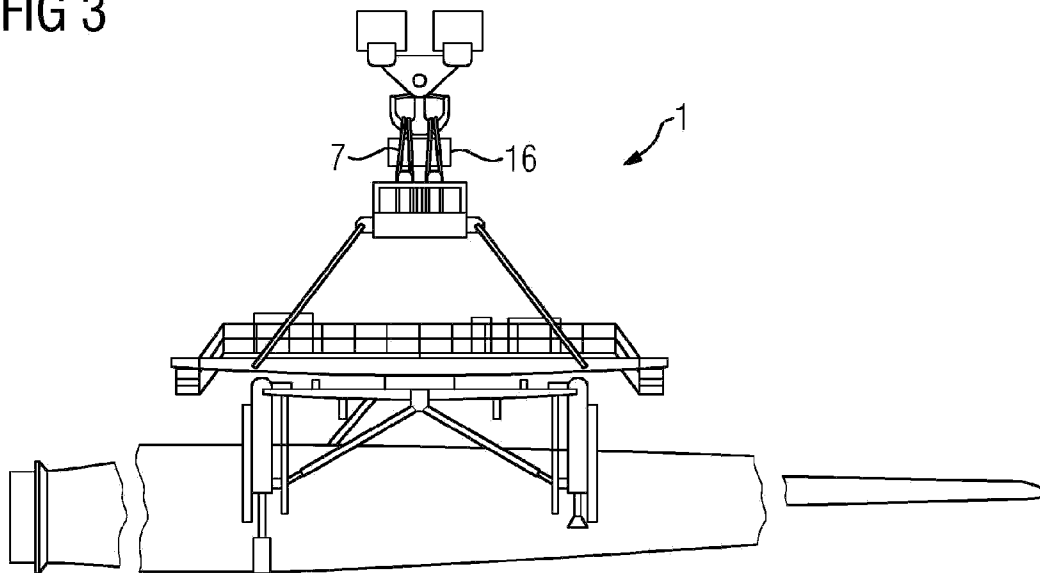

FIG 4

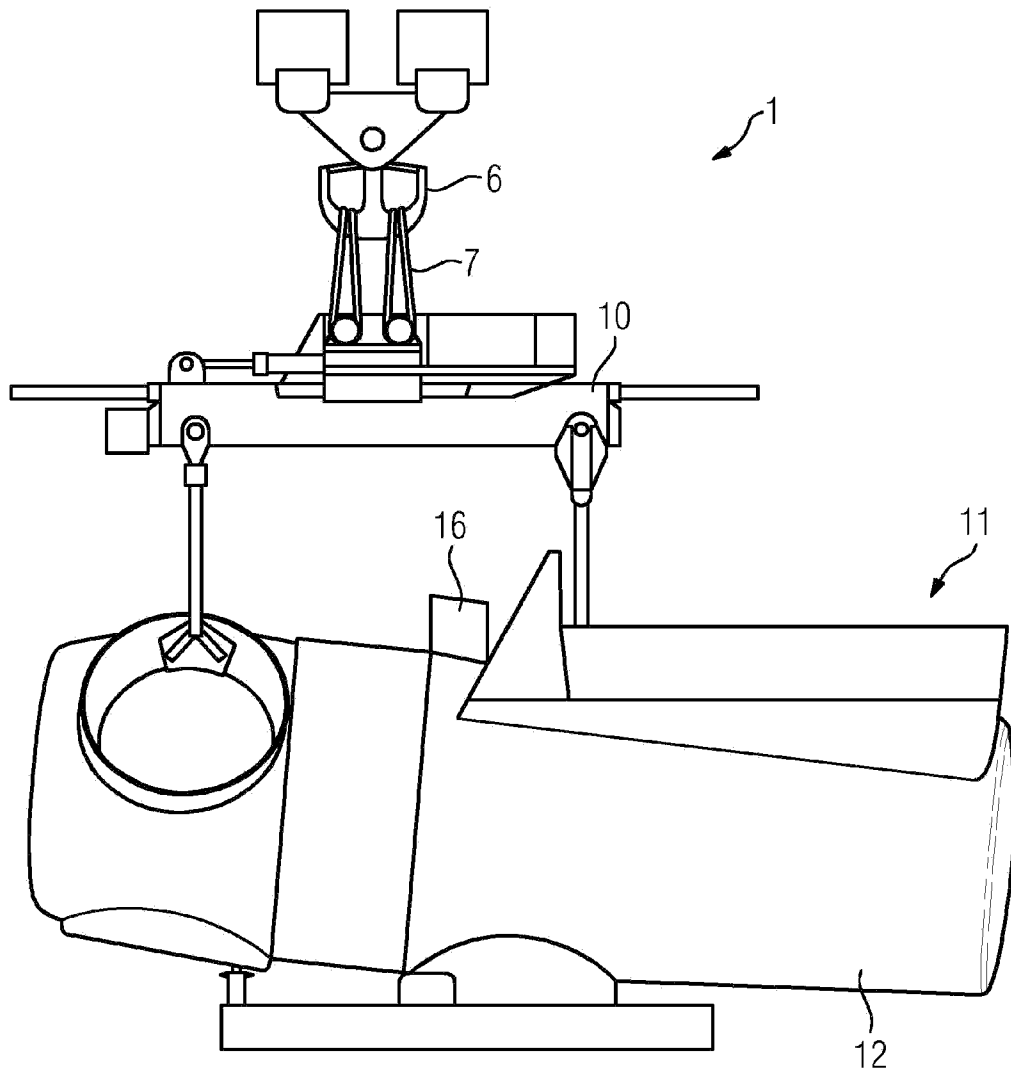

FIG 5

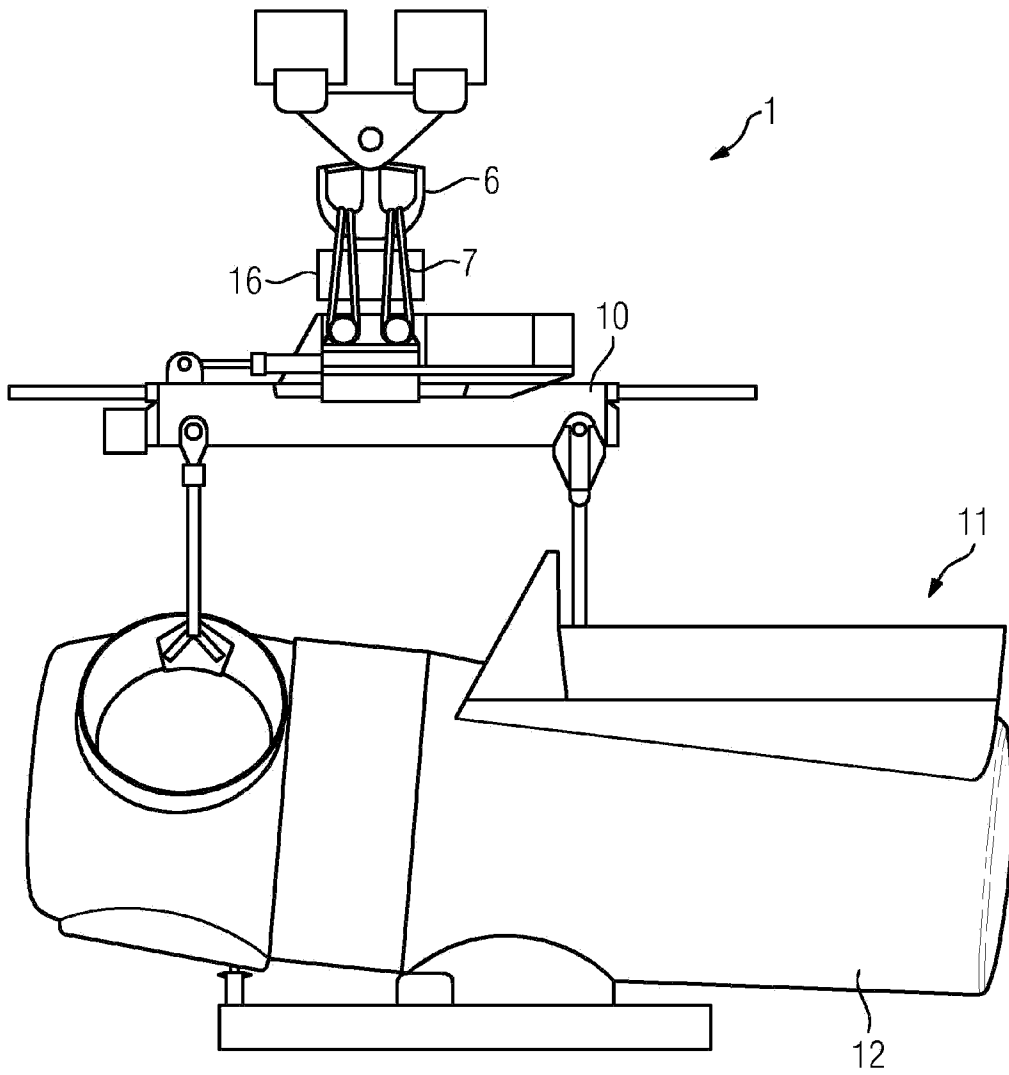

FIG 6

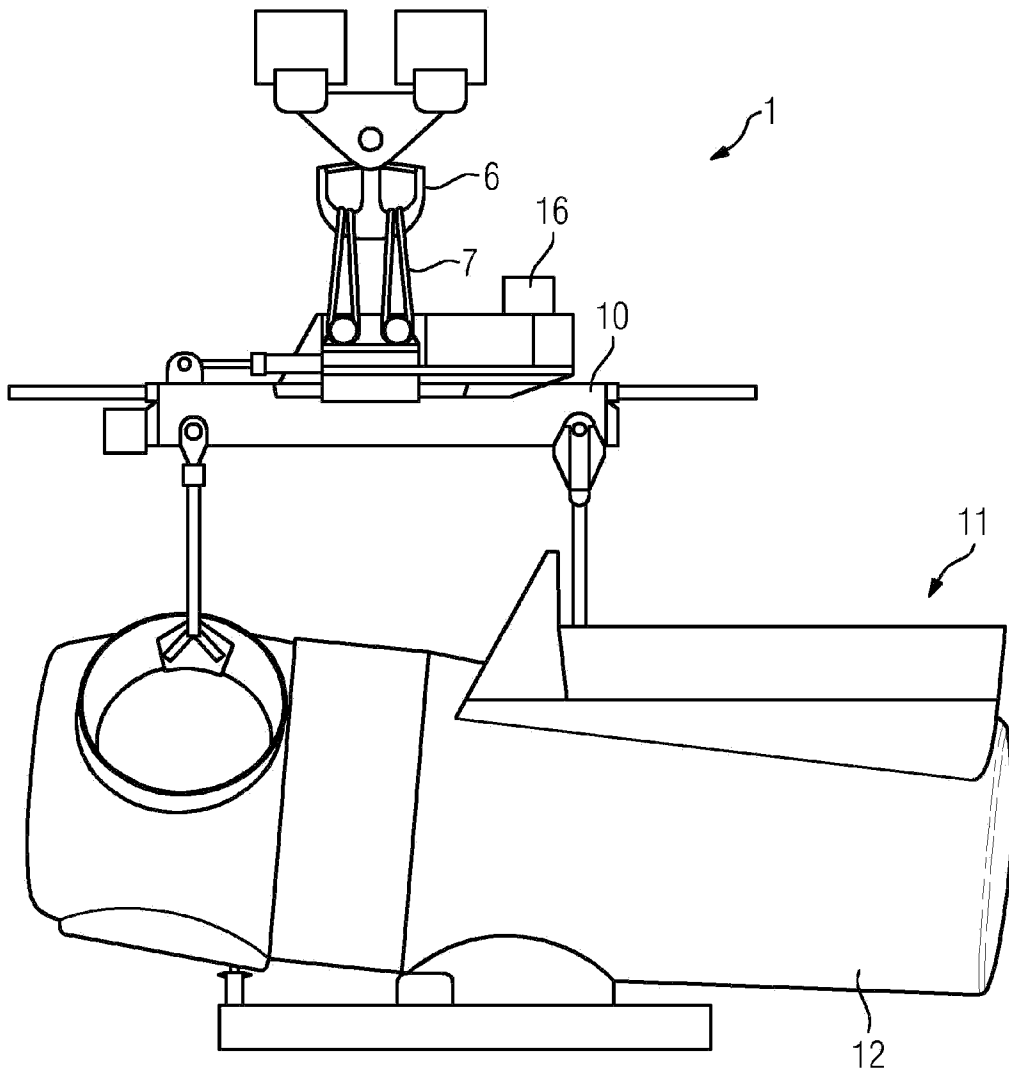

FIG 7

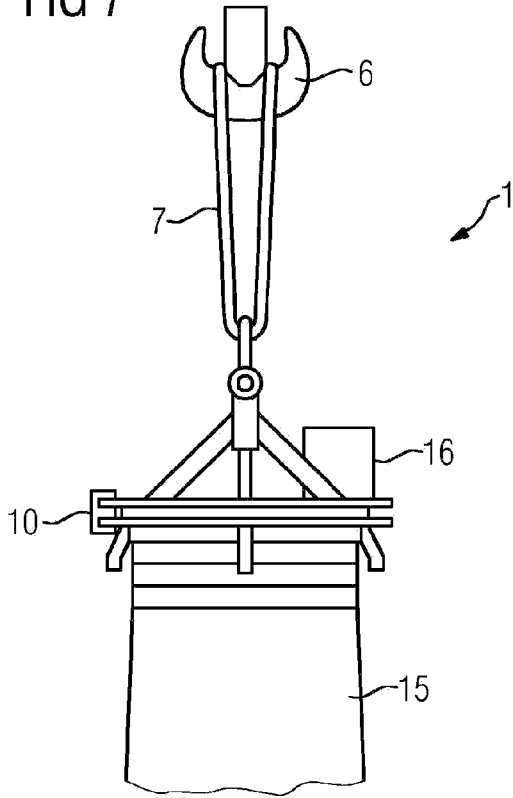

FIG 8

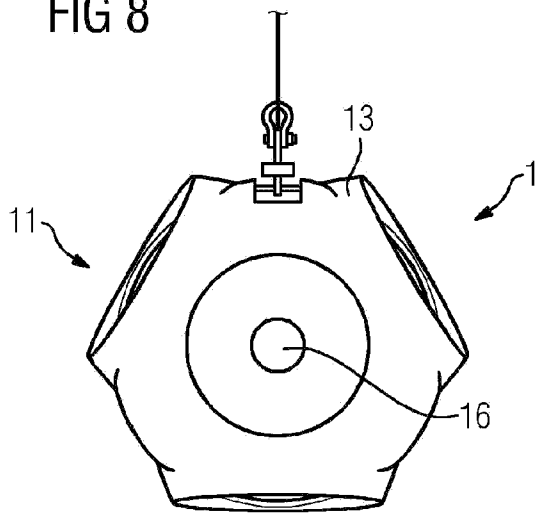

FIG 9

