

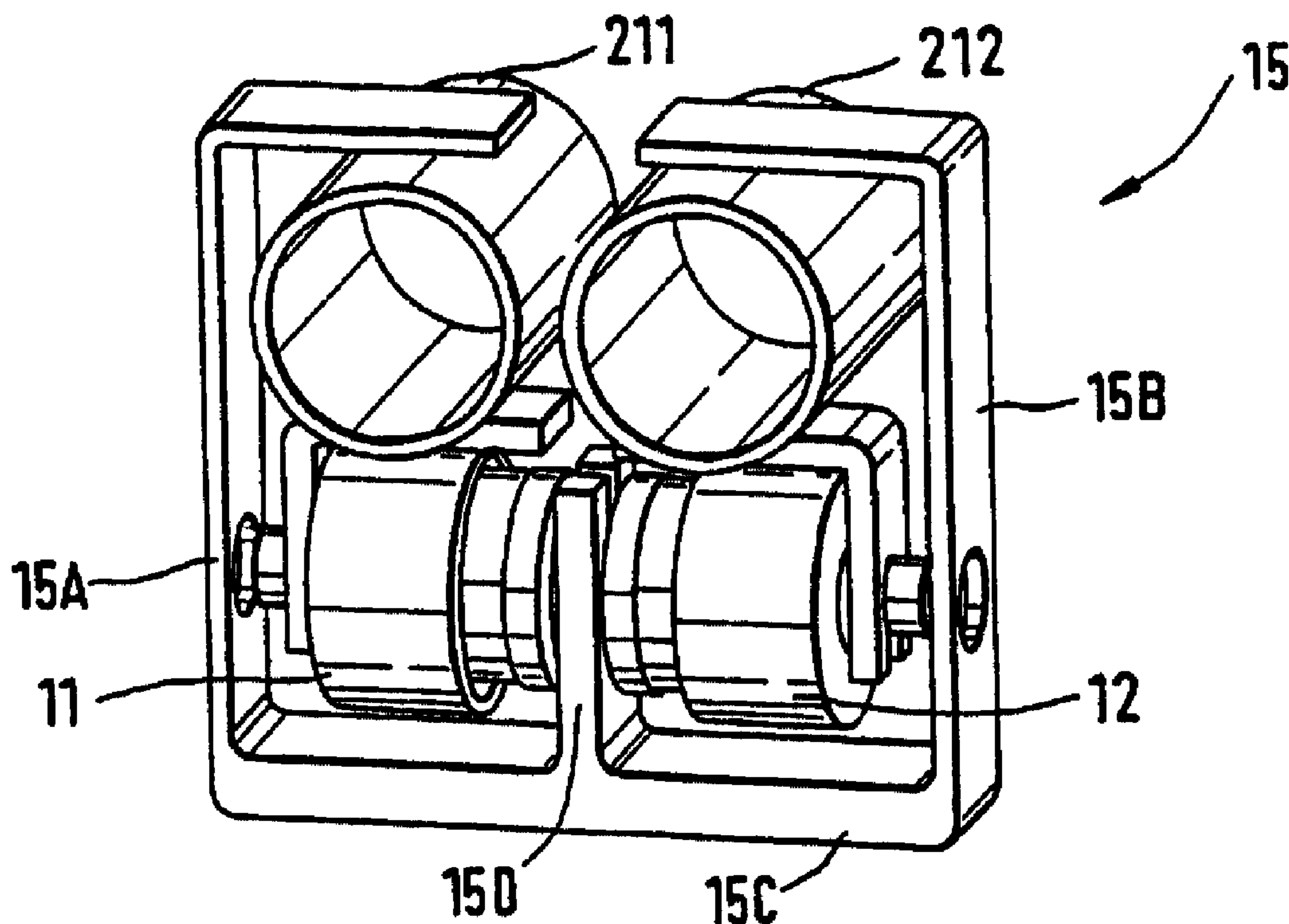

(86) Date de dépôt PCT/PCT Filing Date: 2002/04/24
 (87) Date publication PCT/PCT Publication Date: 2002/11/07
 (45) Date de délivrance/Issue Date: 2009/06/23
 (85) Entrée phase nationale/National Entry: 2003/10/24
 (86) N° demande PCT/PCT Application No.: EP 2002/004500
 (87) N° publication PCT/PCT Publication No.: 2002/088641
 (30) Priorité/Priority: 2001/04/26 (EP01110378.5)

(51) Cl.Int./Int.Cl. *G01F 1/84* (2006.01)
 (72) Inventeurs/Inventors:
 SCHUTZE, CHRISTIAN, CH;
 BITTO, ENNIO, CH
 (73) Propriétaire/Owner:
 ENDRESS + HAUSER FLOWTEC AG, CH
 (74) Agent: SMART & BIGGAR

(54) Titre : ENSEMBLE CIRCUIT MAGNETIQUE POUR UN TRANSDUCTEUR
 (54) Title: MAGNETIC CIRCUIT ARRANGEMENT FOR A TRANSDUCER



(57) Abrégé/Abstract:

The magnetic circuit arrangement, which is preferably used in a fluid-measuring transducer, comprises at least one coil which is traversed in operation by a current. It further comprises two armatures that are fixed to two flow tubes vibrating in phase opposition. The coil is float-mounted by means of a holder to a double flow tube configuration formed by the flow tubes. The armatures are shaped and aligned relative to each other in such a manner that magnetic fields produced by means of the magnetic circuit arrangement are essentially concentrated within the magnetic circuit arrangement, whereby the latter is also largely insensitive to extraneous magnetic fields. The magnetic circuit arrangement is marked by a long service life and, particularly if the transducer is used for fluids with high and/or varying temperatures, by constantly high accuracy in operation.

78639-10

ABSTRACT OF THE DISCLOSURE

Magnetic Circuit Arrangement for a Transducer

The magnetic circuit arrangement, which is preferably used in a fluid-measuring transducer, comprises at least one coil which is traversed in operation by a
5 current. It further comprises two armatures that are fixed to two flow tubes vibrating in phase opposition. The coil is float-mounted by means of a holder to a double flow tube configuration formed by the flow tubes. The armatures are shaped and aligned relative to each other in such a manner that magnetic fields produced by means of the magnetic circuit arrangement are essentially
10 concentrated within the magnetic circuit arrangement, whereby the latter is also largely insensitive to extraneous magnetic fields. The magnetic circuit arrangement is marked by a long service life and, particularly if the transducer is used for fluids with high and/or varying temperatures, by constantly high accuracy in operation.

September 08, 2003

Magnetic Circuit Arrangement for a Transducer

This invention relates to a magnetic circuit arrangement for use in a vibratory transducer and particularly in a Coriolis mass flow sensor.

5 To determine the mass flow rate a fluid flowing in a pipe and particularly of a liquid, use is frequently made of Coriolis mass flowmeters, which, as is well known, induce Coriolis forces in the fluid and derive therefrom a measurement signal representative of mass flow rate by means of a vibratory transducer and control and evaluation electronics connected thereto.

10

Such Coriolis mass flowmeters have been known and in industrial use for a long time. For example, U.S. Patents 4,756,198, 4,801,897, 5,048,350, 5,301,557, 5,349,872, 5,394,758, 5,796,011, and 6,138,517 as well as EP-A 803 713 disclose Coriolis mass flowmeters incorporating a transducer

15

which comprises:

- a double flow tube configuration communicating with the pipe and comprising

-- a first flow tube, which vibrates in operation, and

-- a second flow tube, which vibrates in operation,

20

--- the first and second flow tubes vibrating in phase opposition;

- a vibration exciter for driving the flow tubes; and

- vibration sensors for detecting inlet-side and outlet-side vibrations of the flow tubes and for producing at least one electric sensor signal influenced by the mass flow rate,

25

- the vibration exciter and/or the vibration sensors having at least one magnetic circuit arrangement for converting electric into mechanical energy and/or vice versa which comprises:

September 08, 2003

- at least one coil which is traversed at least temporarily by a current and penetrated at least temporarily by a magnetic field;
- a first armature, fixed to the first vibrating flow tube of the transducer;
- a second armature, fixed to the second vibrating flow tube of the transducer;
- 5 and
- a holder for the coil.

As is well known, bent or straight flow tubes of such transducers, if excited in the so-called useful mode into flexural vibrations according to a first natural
10 vibration mode shape, can cause Coriolis forces in the fluid passing therethrough. These, in turn, result in coplanar flexural vibrations being superimposed on the excited flexural vibrations of the useful mode in the so-called Coriolis mode, so that the vibrations detected by the vibration sensors at the inlet and outlet ends have a measurable phase difference, which is also
15 dependent on the mass flow rate of the fluid.

In operation, the flow tubes of the transducer are usually excited at an instantaneous resonance frequency of the first natural vibration mode, particularly with the vibration amplitude maintained constant. As this resonance
20 frequency is also dependent on the instantaneous density of the fluid in particular, commercially available Coriolis mass flowmeters can also be used to measure the density of moving fluids.

In magnetic circuit arrangements as disclosed in U.S. Patent 5,048,350, both
25 the armature and the associated coil are fixed directly to the double flow tube configuration, so that in operation, both, following the motions of the associated flow tubes, are practically permanently accelerated. The resulting inertial forces, which affect particularly the coil, may lie in ranges far above 10 G (= weight). Even inertial forces up to 30 G are nothing unusual. Because of these high
30 mechanical stresses, the coils in such magnetic circuit arrangements, and

September 08, 2003

particularly their windings, must be highly loadable to ensure a long life of the vibration exciters, particularly a high number of vibration cycles, with unchanged accuracy in operation.

5 In magnetic circuit arrangements as disclosed in U.S. Patents 4,756,198, 5,349,872, or 6,138,517, for example, such mechanical stress on coils is avoided by holding each of the latter in a holding structure that is at rest relative to the vibrating flow tubes, such as a support plate, a meter housing, or a support frame flexibly attached directly to the flow tubes, at a nearly constant
10 distance from a centroidal axis, here a vertical axis, of the double flow tube arrangement.

It turned out, however, that although the above-described mechanical stresses can thus be virtually completely eliminated, the accuracy of such a magnetic
15 circuit arrangement may be seriously affected by, particularly temperature-induced, shifts between the holding structure and the double flow tube configuration as occur, for example, in applications for fluids with widely varying temperatures. Because of the resulting different expansion of the holding structure and the double flow tube configuration, which are neutralizable only
20 limitedly, the rest positions of armature and coil change relative to each other.

While in the magnetic circuit arrangement according to U.S. Patent 6,138,517, mainly a very great temperature difference, and thus a very great expansion difference, may occur between holding structure and double flow tube
25 configuration, in the magnetic circuit arrangements described in U.S. Patent 5,349,872, whose magnetic fields, particularly in the areas of the armatures, are highly inhomogeneous, even slight disturbances may result in considerable inaccuracy. As a result, e.g., if the arrangement is used as a vibration sensor, the sensor signals may have a very poor signal-to-noise ratio
30 and/or exhibit very high harmonic distortion. Furthermore, the magnetic field of

78639-10

4

a magnetic circuit arrangement as disclosed in U.S. Patent 5,349,872 may act through a very large region, i.e., it may also penetrate adjacent components of the transducer and particularly other such magnetic circuit arrangements and/or the flow tubes with the fluid passing therethrough, thus inducing interference voltages, for example. Further disadvantages of such a magnetic circuit arrangement are discussed in detail in U.S. Patent 6,138,517, for example.

To ensure high accuracy in operation despite those temperature-induced interfering effects on the aforementioned magnetic circuit arrangements, the large amount of technical complexity required in such mass flowmeters to compensate for temperature-dependent interferences has to be increased even further.

It is therefore an object of some embodiments of the invention to provide a magnetic circuit arrangement, particularly an arrangement for use in a fluid-measuring vibratory transducer, which has a long service life and particularly a high number of vibration cycles, and which, particularly if the transducer is used for fluids with high and/or varying temperatures, has constantly high accuracy in operation. In addition, the magnetic circuit arrangement according to one embodiment of the invention is to be insensitive to extraneous magnetic fields.

To attain the object, one aspect of the invention provides a magnetic circuit arrangement for converting electric into mechanical energy and/or vice versa which comprises:

- at least a first coil, traversed in operation by a current;
- a first armature, fixed to a first vibrating flow tube of a transducer;
- a second armature, fixed to a second vibrating flow tube of the transducer;
- and
- a holder for the first coil, fixed to the first and second flow tubes,
- the two armatures being shaped and aligned relative to each other in such a way that magnetic fields produced by means of the magnetic circuit

78639-10

5

arrangement are essentially concentrated within the magnetic circuit arrangement, and

- the first coil and at least the first armature interacting via a first magnetic field.

5 In a first embodiment of the invention, the magnetic circuit arrangement comprises a second coil traversed in operation by a current, the second coil and the second armature interacting via a second magnetic field.

10 In a second embodiment of the invention, at least the first armature is shaped and aligned relative to the first coil in such a way that the first magnetic field spreads homogeneously at least at the side of the coil and essentially in alignment with a central axis of the coil.

15 In a third embodiment of the invention, each of the two armatures is cup-shaped.

20 In a fourth embodiment of the invention, the first coil is wound on a first core, and the first core and the first armature are shaped and aligned relative to each other in such a way that the magnetic flux passes through an air gap formed between the two.

In a fifth embodiment of the invention, each of the two cores is cup-shaped.

25 In a sixth embodiment of the invention, the holder comprises a support plate for holding the at least first coil, the support plate being float-mounted by means of a resilient first leg, fixed to the first flow tube, and a resilient second leg, fixed to the second flow tube, to a double flow tube configuration formed by the two flow tubes.

78639-10

6

In a seventh embodiment of the invention, the support plate, extending along the double flow tube configuration, is fixed to the first and second flow tubes at the inlet and outlet ends thereof.

- 5 In an eighth embodiment of the invention, the transducer is a Coriolis mass flow sensor.

In a ninth embodiment of the invention, the magnetic circuit arrangement serves as a vibration exciter for driving the flow tube.

10

In a tenth embodiment of the invention, the magnetic circuit arrangement serves as a vibration sensor for detecting vibrations of the flow tubes.

- 15 A fundamental idea of some embodiments of the invention is, on the one hand, to design at least one of the magnetic circuit arrangements commonly used in such transducers and particularly in Coriolis mass flow sensors or Coriolis mass flow/density sensors, i.e., the vibration exciter and/or the vibration sensors, in such a way that in operation, their coils remain in a rest position at least relative to a centroidal
- 20 axis of the double flow tube configuration, particularly to the vertical axis of the latter. On the other hand, some embodiments of the invention are aimed at providing a magnetic circuit arrangement that is largely insensitive to temperature influences and whose magnetic field can be prevented from acting on other components while the arrangement itself is effectively shielded from other magnetic fields.

78639-10

6a

One specific aspect of the invention provides a magnetic circuit arrangement for converting electrical energy into mechanical energy and/or vice versa, the arrangement being adapted for use with a first vibrating flow tube and a second vibrating flow tube of a transducer, the arrangement comprising: a first armature, fixed to the first vibrating flow tube of the transducer; a second armature, fixed to the second vibrating flow tube of the transducer; a first coil, traversed in operation by a current, said first coil and at least said first armature interacting via a first magnetic field; a second coil interacting with said second armature via a second magnetic field; and a holder for said first and second coils, said holder being fixed to said first and second flow tubes, wherein: said first and second coils are fixed to the holder and the second coil is aligned with the first coil.

There is also provided a magnetic circuit arrangement for converting electrical energy into mechanical energy and/or vice versa, said magnetic circuit arrangement comprising: a first armature, fixed to a first vibrating flow tube of a transducer; a second armature, fixed to a second vibrating flow tube of the transducer; at least a first coil, traversed in operation by a current, said first coil and at least said first armature interacting via a first magnetic field; and a holder for said first coil, said holder being fixed to said first and second flow tubes; wherein: each of said first and second armatures is cup-shaped.

Another aspect of the invention provides a magnetic circuit arrangement for converting electrical energy into mechanical energy and/or vice versa, said magnetic circuit arrangement comprising: a first armature, fixed to a first vibrating flow tube of a transducer; a

78639-10

6b

second armature, fixed to a second vibrating flow tube of the transducer; at least a first coil, traversed in operation by a current, said first coil and at least said first armature interacting via a first magnetic field; and a holder for said first coil, said holder being fixed to said first and second flow tubes; wherein the first and second flow tubes form a double flow tube configuration having an imaginary middle plane located between said first and said second flow tubes, said middle plane corresponds to a plane of symmetry of said double flow tube configuration; and wherein the first coil is fixed to said holder such that a central axis of the first coil is essentially perpendicular to said imaginary middle plane of said double flow tube.

In accordance with a still further aspect of the invention, there is provided a magnetic circuit arrangement for converting electrical energy into mechanical energy and/or vice versa, said magnetic circuit arrangement comprising: a first armature and a second armature, said first armature being fixed to a first vibrating flow tube of a transducer, said second armature being fixed to a second vibrating flow tube of said transducer; a first coil and a second coil, in operation each of said coils being traversed by a current, said first coil and said first armature interacting via a first magnetic field; said second coil and said second armature interacting via a second magnetic field; and a holder for said first and second coil, said holder being fixed to said first and second flow tubes.

Illustrative embodiments of the invention and further advantages will become more apparent by reference to the following description taken in conjunction with the accompanying drawings. Like reference characters have been used to designate like parts throughout the various figures; reference characters that

78639-10

7

were already used in preceding figures are not repeated in subsequent figures if this contributes to clarity. In the drawings:

- 5 Fig. 1 is a perspective view of a first variant of a magnetic circuit arrangement particularly suited for Coriolis-type transducers;
- Fig. 2 is a part-sectional front view of the magnetic circuit arrangement of Fig. 1;
- 10 Fig. 3 is a part-sectional front view of a second variant of a magnetic circuit arrangement particularly suited for Coriolis-type transducers;
- 15 Fig. 4 is a perspective view of the magnetic circuit arrangement of Fig. 1, used in a transducer with a double flow tube configuration; and
- Figs.5 and 6 are perspective views of further developments of the magnetic circuit arrangement according to an embodiment of the invention, used in a transducer.

20

Figs. 1 to 3 show embodiments of a magnetic circuit arrangement for converting electric into mechanical energy and/or, based on the law of electromagnetic induction, for converting mechanical into electric energy. The magnetic circuit arrangement is particularly suited for use in a Coriolis mass flowmeter or a
25 Coriolis mass flowmeter-densimeter. A corresponding embodiment of a vibratory transducer, which responds to the mass flow rate m of a fluid flowing in a pipe (not shown), is shown in Fig. 4. As is well known, such a mass flow sensor, if used as a physical-to-electrical transducer in a Coriolis mass
30 flowmeter, serves to produce and detect Coriolis forces in the fluid passing

September 08, 2003

therethrough and to convert these forces into useful input signals for subsequent evaluation electronics.

To conduct the fluid to be measured, the transducer comprises a double flow tube configuration 21 with a first flow tube 211 and a second flow tube 212, which is preferably identical in shape to flow tube 211. As is usual with such transducers, flow tubes 211, 212 may be curved singly, e.g., U-shaped, or in the form of a loop; if necessary, however, they may also be straight.

10 Preferably, as shown in Fig. 4, flow tubes 211, 212 are so aligned relative to each other that an imaginary middle plane between the two tubes, which are preferably parallel to each other, corresponds to a first plane of symmetry of double flow tube configuration 21. Furthermore, double flow tube configuration 21 is advantageously shaped so as to have a second plane of symmetry that intersects the middle plane E_1 , which also contains the above-mentioned vertical axis, particularly at right angles.

Each of the two flow tubes 211, 212 ends in an inlet manifold 213 and an outlet manifold 214. If the meter is installed in the fluid-conducting pipe, inlet manifold 213 and outlet manifold 214 are respectively connected with straight inlet-side and outlet-side sections of the pipe and are therefore preferably aligned with each other and with a longitudinal axis A_1 of double flow tube configuration 21 which joins the two, as is usual with such transducers. If the transducer is to be detachable from the pipe, a first flange 215 and a second flange 216 are preferably formed on inlet manifold 213 and outlet manifold 214, respectively; if necessary, however, inlet manifold 213 and outlet manifold 214 may also be connected with the pipe directly, e.g., by welding or brazing.

In operation, flow tubes 211, 212, as mentioned above, are excited in the useful mode into flexural vibrations, particularly at a natural resonance frequency of an

September 08, 2003

eigenmode, such that they vibrate in phase opposition, as is usual with such transducers. As is well known, the Coriolis forces thus induced in the fluid passing through flow tubes 211, 212 cause an additional elastic deformation of the tubes, also referred to as the Coriolis mode, which is superimposed on the
5 excited vibrations of the useful mode and is also dependent on the mass flow rate m to be measured.

If necessary, any mechanical stresses caused by the vibrating flow tubes 211, 212 in inlet manifold 213 and outlet manifold 214 can be minimized, for
10 example, by mechanically joining the tubes by means of at least a first node plate 217 at the inlet end and at least a second node plate 218 at the outlet end, as is usual with such transducers.

To drive flow tubes 211, 212, the transducer comprises at least one vibration
15 exciter 22. The latter serves to convert electric excitation energy E_{exc} , supplied from control electronics of, e.g., the above-mentioned mass flowmeter, into excitation forces F_{exc} , e.g., pulsating or harmonic excitation forces, which act on flow tubes 211, 212 symmetrically, i.e., simultaneously and uniformly, but in
20 opposite directions, thus producing the antiphase vibrations of flow tubes 211, 212. The excitation forces F_{exc} may be adjusted in amplitude, e.g., by means of a current- and/or voltage-regulator circuit, and in frequency, e.g., by means of a phase-locked loop, in the manner familiar to those skilled in the art, see also U.S. Patent 4,801,897.

25 To detect vibrations of flow tubes 211 and 212, the transducer comprises an inlet-side first vibration sensor 23 and an outlet-side second vibration sensor 24, which respond to motions of the tubes, particularly to their lateral deflections, and deliver corresponding first and second vibration signals S_{23} and
30 S_{24} , respectively.

September 08, 2003

In transducers of the kind described, the magnetic circuit arrangement according to the invention, if used as vibration exciter 22, may serve to produce the excitation forces F_{exc} driving the flow tubes 211, 212. Furthermore, the magnetic circuit arrangement, as mentioned above, may be used as vibration
5 sensor 23 or 24 for sensing the motions of flow tubes 211, 212 and for generating vibration signal S_{23} or S_{24} , respectively.

To interconvert mechanical and electric energy, the magnetic circuit arrangement comprises at least a first, preferably cylindrical, coil 13, which is
10 traversed in operation by a current and which is attached to double flow tube configuration 21 by means of a holder 15. Preferably, a second coil 14, particularly a coil aligned with coil 13, is fixed to holder 15.

Furthermore, the magnetic circuit arrangement comprises a first armature 11,
15 which is fixed to flow tube 211 and which in operation interacts with the current-carrying coil 13 via a first magnetic field B_1 , and a second armature 12, particularly an armature identical in shape to armature 11, which is fixed to flow tube 212 and can interact with coil 14 via a second magnetic field B_2 . Magnetic field B_1 may be, for example, an alternating field which is produced by means of
20 coil 13 and on which a steady field produced by means of armature 11 may be modulated; analogously, magnetic field B_2 may be produced by means of coil 14 and armature 12, for example.

The two armatures 11, 12 also serve to homogenize magnetic fields produced
25 by the magnetic circuit arrangement, particularly magnetic field B_1 and magnetic field B_2 , also outside coil 13, and to concentrate these fields within as narrow a space as possible which lies essentially within the magnetic circuit arrangement itself. Armatures 11, 12 also serve to shape and direct the
aforementioned magnetic fields in such a manner that they have as high a flux
30 density as possible, particularly a constant flux density, even in air. Therefore,

September 08, 2003

armatures 11, 12 are preferably made at least in part of ferromagnetic material, which, as is well known, has a very high permeability and thus concentrates magnetic fields.

5 In a preferred embodiment of the invention, armature 11 also serves to produce a permanent steady component of magnetic field B_1 ; analogously, a permanent steady component of magnetic field B_2 is preferably produced by means of armature 12. Particularly in that case, armatures 11, 12 are made at least in part of hard magnetic, i.e., premagnetizable, material, such as AlNiCo, NyFeB,
10 SmCo, or another rare-earth alloy. It is also possible to use far less expensive free-cutting steel or structural steel as the material for this embodiment of armatures 11, 12.

As shown in Figs. 1 to 3, armature 11 is rigidly fixed to flow tube 11 by means
15 of a mounted-on, flexurally stiff first angle piece 11A, and armature 12 is rigidly fixed to flow tube 212 by means of a mounted-on, flexurally stiff second angle piece 12A. Angle pieces 11A and 12A may be joined to flow tubes 211 and 212, respectively, by welding or brazing, for example.

20 As shown in Fig. 1, for example, coil 13, and also coil 14 if present, is fixed by means of holder 15 to both flow tubes 211, 212, such that an axis of symmetry of the magnetic circuit arrangement is virtually parallel to middle plane E_1 of double flow tube configuration 21. Preferably, holder 15 is fixed to flow tube 211 via a first leg 15A and to flow tube 212 via an essentially identically shaped
25 second leg 15B. Furthermore, the two, preferably resilient, legs 15A, 15B are, preferably rigidly, interconnected at the respective ends remote from double flow tube configuration 21 via a support plate 15C. Holder 15 may either be a single part, such as a bent stamping, or be of multipart construction. It may be made of the same materials as those used for flow tubes 211, 212, for
30 example.

September 08, 2003

If flow tubes 211, 212 vibrate in phase opposition in the manner described above, holder 15 will be deformed, particularly by lateral deflection of legs 15A, 15B attached to flow tubes 211, 212, but its symmetry axis will essentially
5 remain in its position relative to middle plane E_1 . Thus, coil 13, held by support plate 15C, e.g., via a ridge portion 15D formed on the latter, is float-mounted to double flow tube configuration 21 and kept at an essentially constant distance from middle plane E_1 .

10 To prevent the vibration mode shape of the vibrating flow tubes 211, 212 from being influenced by holder 15, the latter must be made pliable. To accomplish this, legs 15A, 15B, which also vibrate in operation, may be formed from suitably thin sheet-metal strip.

15 In another embodiment of the invention, support plate 15C, as shown schematically in Fig. 5 or 6, is shaped and attached to flow tubes 211, 212 in such a way as to extend essentially parallel to the flow tubes and virtually along the entire length of double flow tube configuration 21. In that case, support plate 15C is advantageously fastened directly to node plate 217 at the inlet end
20 and to node plate 218 at the outlet end. To the inventors' surprise it turned out that, if the, e.g., thermally induced, expansions of flow tubes 211, 212 are parallel to the middle plane E_1 , the holder 15 so fixed can follow these expansions to the point that any relative shift between holder 15 and double flow tube configuration 21 is negligibly small.

25

A particular advantage of this embodiment of the invention is that it eliminates the need to additionally fix holder 15 to double flow tube configuration 21 via legs 15A, 15B, cf. Fig. 6.

September 08, 2003

According to a first variant of the invention, the magnetic circuit arrangement is of the electrodynamic type, i.e., an arrangement in which an electric conductor formed into a loop, e.g., coil 13, is penetrated, particularly perpendicularly, by a magnetic field produced by at least one permanent magnet, and in which the
5 loop and the permanent magnet are moved relative to each other. To this end, coil 13 is preferably fixed to double flow tube configuration 21 by means of holder 15 in such a way that its central axis A_{13} is essentially perpendicular to middle plane E_1 .

10 To homogenize the magnetic field B_1 , B_2 and fix as high a flux density as possible, particularly outside armatures 11, 12, in a preferred embodiment of the first variant of the invention, each of the two armatures 11, 12, as shown schematically in Figs. 1 and 2, has the form of a cup whose bottom has a,
preferably hard magnetic, rod formed thereon which is coaxial with the wall of
15 the cup.

In another preferred embodiment of the first variant, armatures 11, 12, as is usual with such magnetic circuit arrangements, are preferably made at least in part, i.e., in the region of the above-mentioned wall of the cup, of soft magnetic
20 material, such as ferrite or Corovac.

According to a second variant of the invention, the magnetic circuit arrangement is of the electromagnetic type, i.e., an arrangement in which two ferromagnetic bodies movable relative to each other are so arranged relative to
25 each other that at least one variable air gap formed between the two is penetrated by a, preferably homogeneous, magnetic field of high flux density, cf. particularly EP-A 803 713.

In this second variant of the invention, the magnetic circuit arrangement further
30 comprises a ferromagnetic first core 13A for coil 13, the core being fixed to

September 08, 2003

holder 15. As shown in Fig. 3, core 13A, extending through at least part of coil 13, is located opposite to and spaced from armature 11. In this second variant of the invention, core 13A and armature 11 serve to form a variable first air gap, across which the magnetic field B_1 extends at least in part. Preferably, the
5 magnetic circuit arrangement further comprises a ferromagnetic second core 14A for coil 14, this second core being also fixed to holder 15 at a distance from armature 12. Thus, core 14A and armature 12 form a variable air gap, particularly an air gap penetrated by magnetic field B_2 .

10 To produce permanent steady components of the magnetic fields and attenuate eddy currents in the magnetic circuit arrangement, each of cores 13A is preferably made at least in part of hard magnetic, but poorly conducting material, such as of any one of the aforementioned rare-earth alloys AlNiCo, NyFeB, SmCo, etc.

15

To fix a reluctance for magnetic field B_1 that is as low as possible even outside core 13A, in a preferred embodiment of the second variant of the invention, a ferromagnetic first yoke 13B extending outside coil 13 is formed integrally with core 13A, as shown in Fig. 13; analogously, core 14A may have a
20 ferromagnetic second yoke 14B for magnetic field B_2 formed thereon, which is preferably identical in shape to yoke 13B. Advantageously, as is usual with such magnetic circuit arrangements, yoke 13B, 14B may be made of soft magnetic materials, such as ferrite or Corovac.

25 In a further preferred embodiment of the invention, core 13A and yoke 13B are shaped and aligned relative to each other in such a way that the free end faces of core 13A

and yoke 13B which are in contact with the air gap are essentially flat and
30 coplanar. Then, the free end face of armature 11 that is in contact with the air

78639-10

15

gap will preferably also be flat. In that case, this end face may also be parallel to the opposite free end faces of core 13A and yoke 13B, for example. If necessary, armature 11, core 13A, and yoke 13B may be constructed on the coil-and-plunger principle.

5

In a further preferred embodiment of the second variant of the invention, yoke 13B is designed as a coil can, particularly as a can coaxial with coil 13, cf. EP-A 803 713.

10 Further details and embodiments concerning the operation of a magnetic circuit arrangement according to the second variant of the invention or concerning the shape and arrangement of coil 13 and yoke 13B, and of coil 14 and yoke 14B if present, are disclosed, for example, in applicant's EP-A 803 713.

78639-10

16

CLAIMS:

1. A magnetic circuit arrangement for converting electrical energy into mechanical energy and/or vice versa, the arrangement being adapted for use with a first vibrating
5 flow tube and a second vibrating flow tube of a transducer, the arrangement comprising:

a first armature, fixed to the first vibrating flow tube of the transducer;

a second armature, fixed to the second vibrating
10 flow tube of the transducer;

a first coil, traversed in operation by a current, said first coil and at least said first armature interacting via a first magnetic field;

a second coil interacting with said second
15 armature via a second magnetic field;

and a holder for said first and second coils, said holder being fixed to said first and second flow tubes, wherein: said first and second coils are fixed to the holder and the second coil is aligned with the first coil.

20 2. A magnetic circuit arrangement as set forth in claim 1, wherein: each of said first and second armatures is cup-shaped.

3. A magnetic circuit arrangement as set forth in claim 1, wherein: said first flow tube and said second flow
25 tube forming a double flow tube configuration: said holder comprises a support plate for holding said at least first coil; said support plate is mounted to said double flow tube configuration by means of a resilient first leg, fixed to the first flow tube and by means of a resilient second leg,

78639-10

17

fixed to the second flow tube; and said first and said second legs vibrate in operation.

4. A magnetic circuit arrangement as set forth in claim 3, wherein: said support plate, extending along the double flow tube configuration, is fixed to the first and second flow tubes at the inlet and outlet ends thereof.

5. A magnetic circuit arrangement as set forth in claim 1, wherein: the transducer is a Coriolis mass flow sensor.

10 6. The use of the magnetic circuit arrangement as set forth in claim 1 as a vibration exciter for driving the flow tubes.

7. The use of the magnetic circuit arrangement as set forth in claim 1 as a vibration sensor for detecting vibrations of the flow tubes.

8. A magnetic circuit arrangement as set forth in claim 1, wherein: said first and second flow tubes form a double flow tube configuration having an imaginary middle plane located between said first and second flow tubes; said middle plane corresponding to a plane of symmetry of said double flow tube configuration; and said first coil is fixed to said holder such that a central axis of said first coil is essentially perpendicular to said imaginary middle plane of said double flow tube.

25 9. A magnetic circuit arrangement as set forth in claim 2, wherein: each of said cup-shaped first and second armatures having a rod formed on a cup-bottom of the respective structure.

78639-10

18

10. A magnetic circuit arrangement for converting electrical energy into mechanical energy and/or vice versa, said magnetic circuit arrangement comprising:

5 a first armature, fixed to a first vibrating flow tube of a transducer;

a second armature, fixed to a second vibrating flow tube of the transducer;

10 at least a first coil, traversed in operation by a current, said first coil and at least said first armature interacting via a first magnetic field; and

a holder for said first coil, said holder being fixed to said first and second flow tubes; wherein: each of said first and second armatures is cup-shaped.

11. A magnetic circuit arrangement as claimed in claim 10, wherein: each of said cup-shaped first and second armatures having a rod formed on a cup-bottom of the respective armature.

12. A magnetic circuit arrangement as claimed in claim 10, wherein: the first and second flow tubes form a double flow tube configuration having an imaginary middle plane located between said first and said second flow tubes; said middle plane corresponds to a plane of symmetry of said double flow tube configuration; and wherein the first coil is fixed to said holder that a central axis of the first coil is essentially perpendicular to said imaginary middle plane of said double flow tube.

13. A magnetic circuit arrangement as claimed in claim 10, wherein: the holder comprises a support plate for holding the at least first coil; said support plate being mounted to said double flow tube configuration by means of a

78639-10

19

resilient first leg, fixed to the first flow tube; and by means of a resilient second leg, fixed to the second flow tube, said first and said second legs vibrate in operation.

14. A magnetic circuit arrangement as claimed in claim 10, which comprises: a second coil traversed in operation by a current, said second coil and said second armature interacting via a second magnetic field, wherein: the second coil is aligned with said first coil.

15. A magnetic circuit arrangement for converting electrical energy into mechanical energy and/or vice versa, said magnetic circuit arrangement comprising:

a first armature, fixed to a first vibrating flow tube of a transducer;

a second armature, fixed to a second vibrating flow tube of the transducer;

at least a first coil, traversed in operation by a current, said first coil and at least said first armature interacting via a first magnetic field; and

a holder for said first coil, said holder being fixed to said first and second flow tubes;

wherein the first and second flow tubes form a double flow tube configuration having an imaginary middle plane located between said first and said second flow tubes, said middle plane corresponds to a plane of symmetry of said double flow tube configuration; and

wherein the first coil is fixed to said holder such that a central axis of the first coil is essentially perpendicular to said imaginary middle plane of said double flow tube.

78639-10

20

16. A magnetic circuit arrangement as claimed in claim 15, wherein: the holder comprises a support plate for holding the at least first coil; said support plate being mounted to said double flow tube configuration by means of a resilient first leg, fixed to the first flow tube; and by means of a resilient second leg, fixed to the second flow tube, said first and said second legs vibrate in operation.

17. A magnetic circuit arrangement as claimed in claim 15, which comprises: a second coil traversed in operation by a current, said second coil and said second armature interacting via a second magnetic field; wherein the second coil is aligned with said first coil.

18. A magnetic circuit arrangement for converting electrical energy into mechanical energy and/or vice versa, said magnetic circuit arrangement comprising:

a first armature and a second armature, said first armature being fixed to a first vibrating flow tube of a transducer, said second armature being fixed to a second vibrating flow tube of said transducer;

a first coil and a second coil, in operation each of said coils being traversed by a current, said first coil and said first armature interacting via a first magnetic field; said second coil and said second armature interacting via a second magnetic field; and

a holder for said first and second coil, said holder being fixed to said first and second flow tubes.

19. A magnetic circuit arrangement as claimed in claim 18, wherein: the first and second coils are fixed to the holder that the second coil is aligned with said first coil.

78639-10

21

20. A magnetic circuit arrangement as claimed in claim 18, wherein: the holder comprises a support plate for holding said first and said second coils; said support plate being mounted to said double flow tube configuration by means of a resilient first leg, fixed to the first flow tube; and by means of a resilient second leg, fixed to the second flow tube, said first and said second legs vibrate in operation.

SMART & BIGGAR
OTTAWA, CANADA

PATENT AGENTS

Fig.1

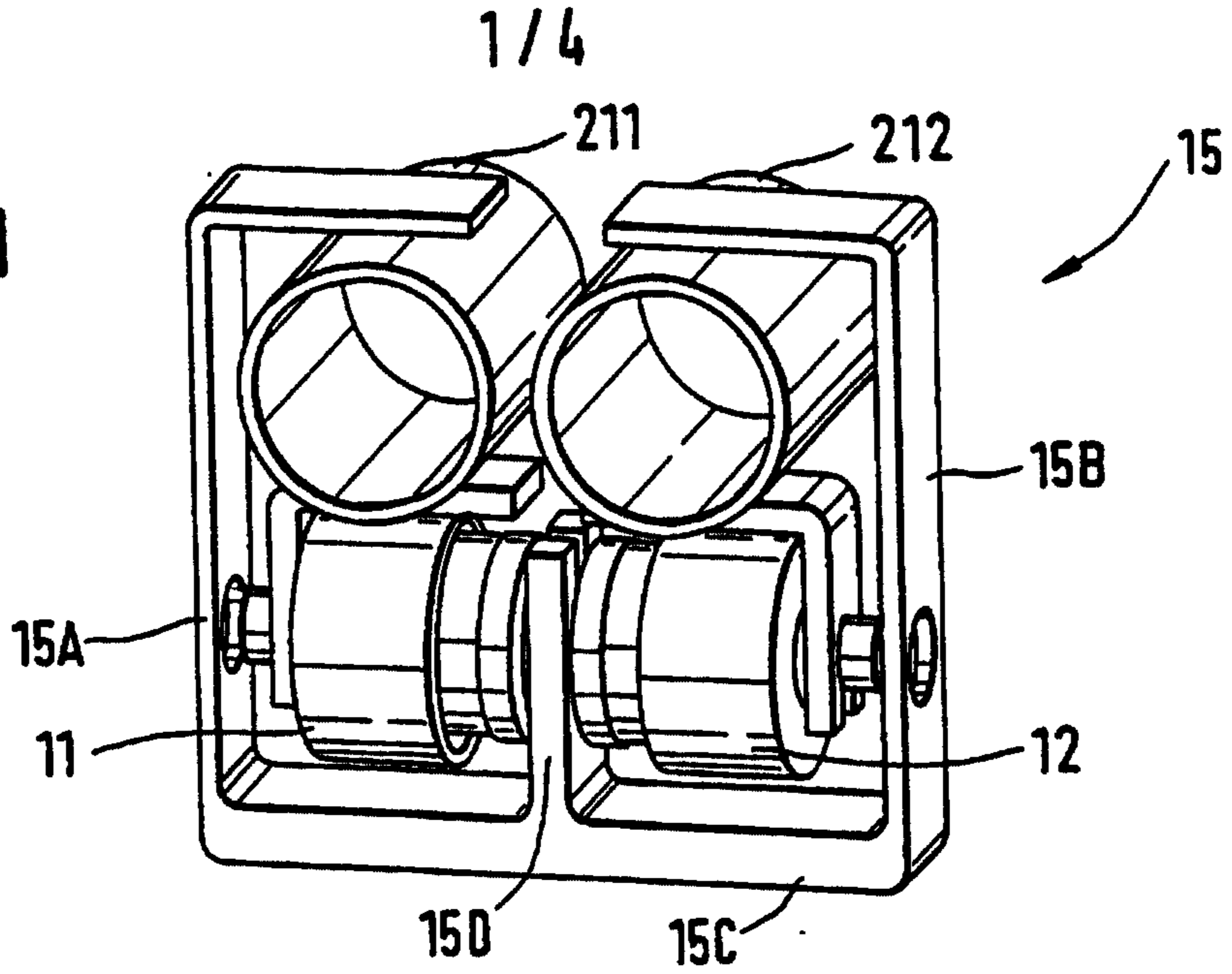

Fig.2

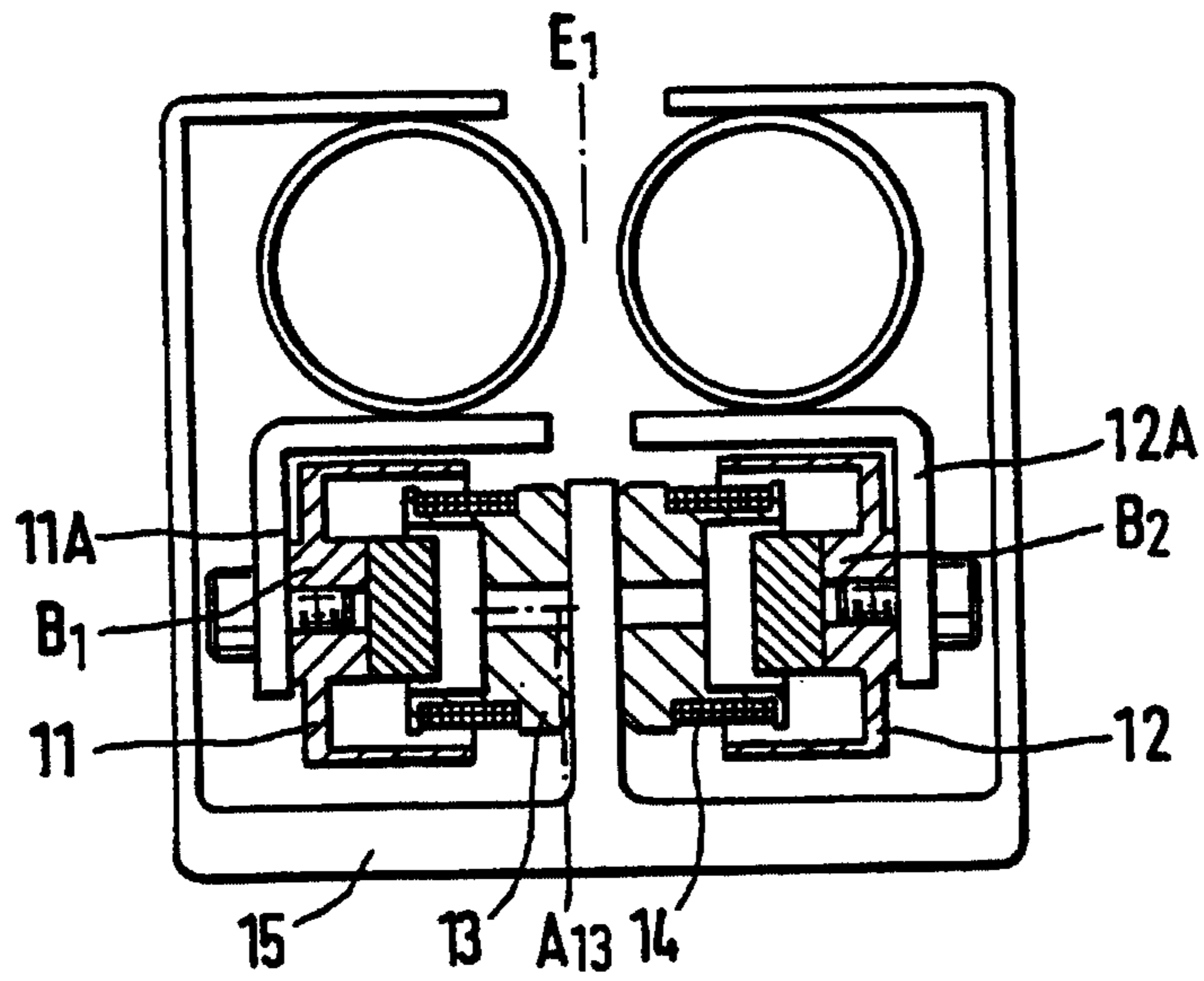
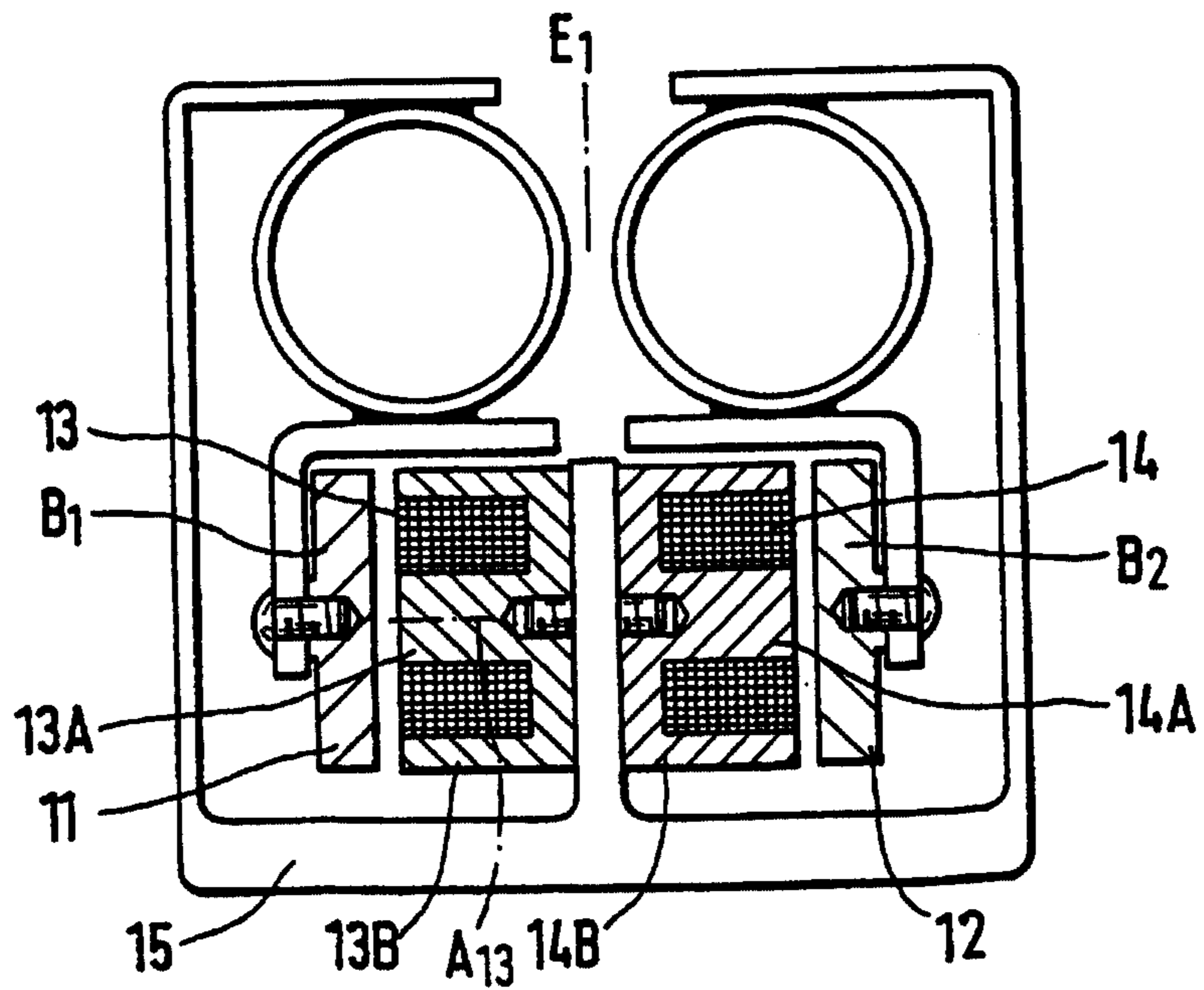
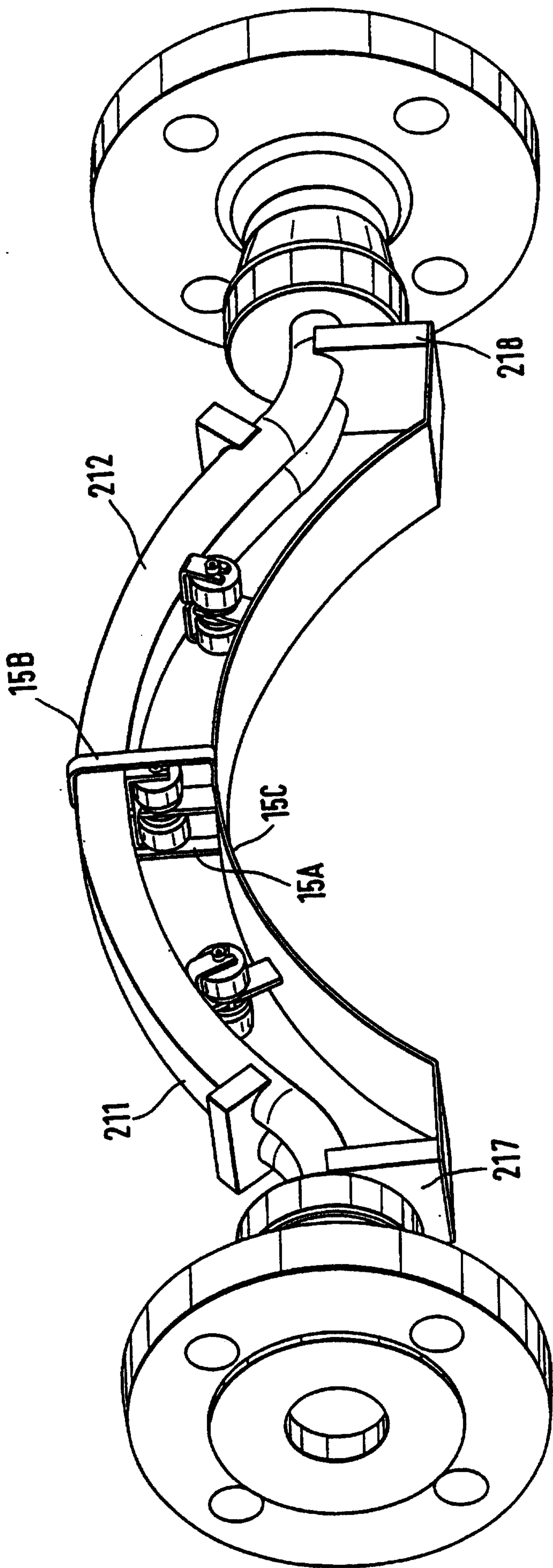

Fig.3



3 / 4

Fig. 5



4 / 4

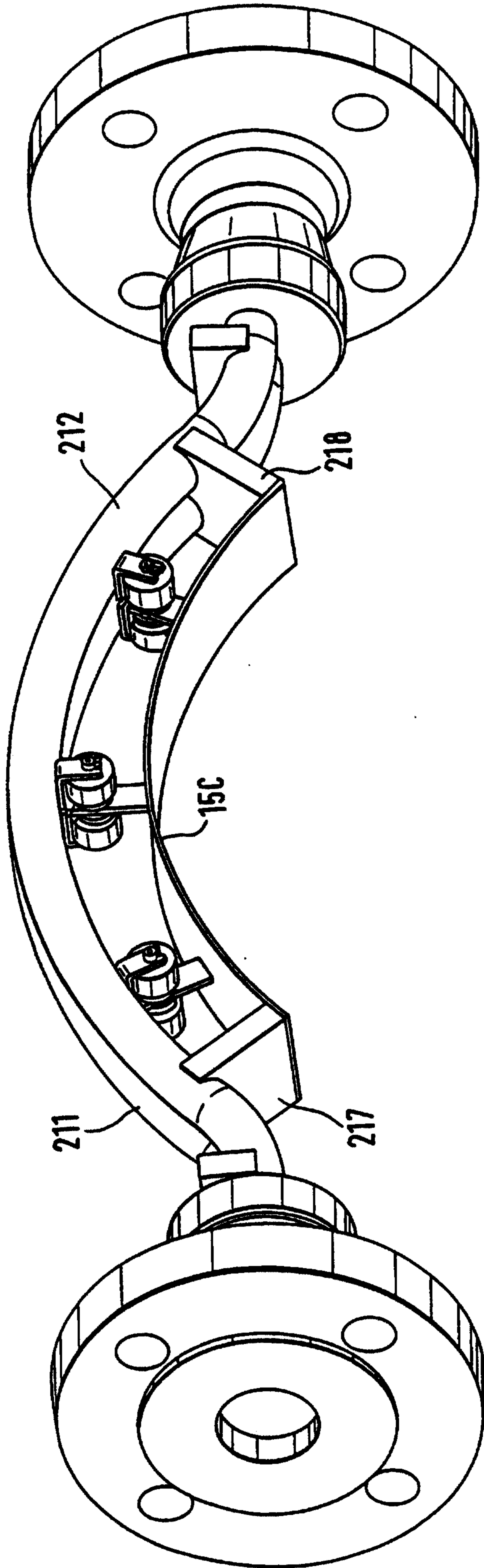

Fig. 6

