

J. F. AYERS.
WINDMILL.

APPLICATION FILED JUNE 1, 1906.

4 SHEETS—SHEET 1.

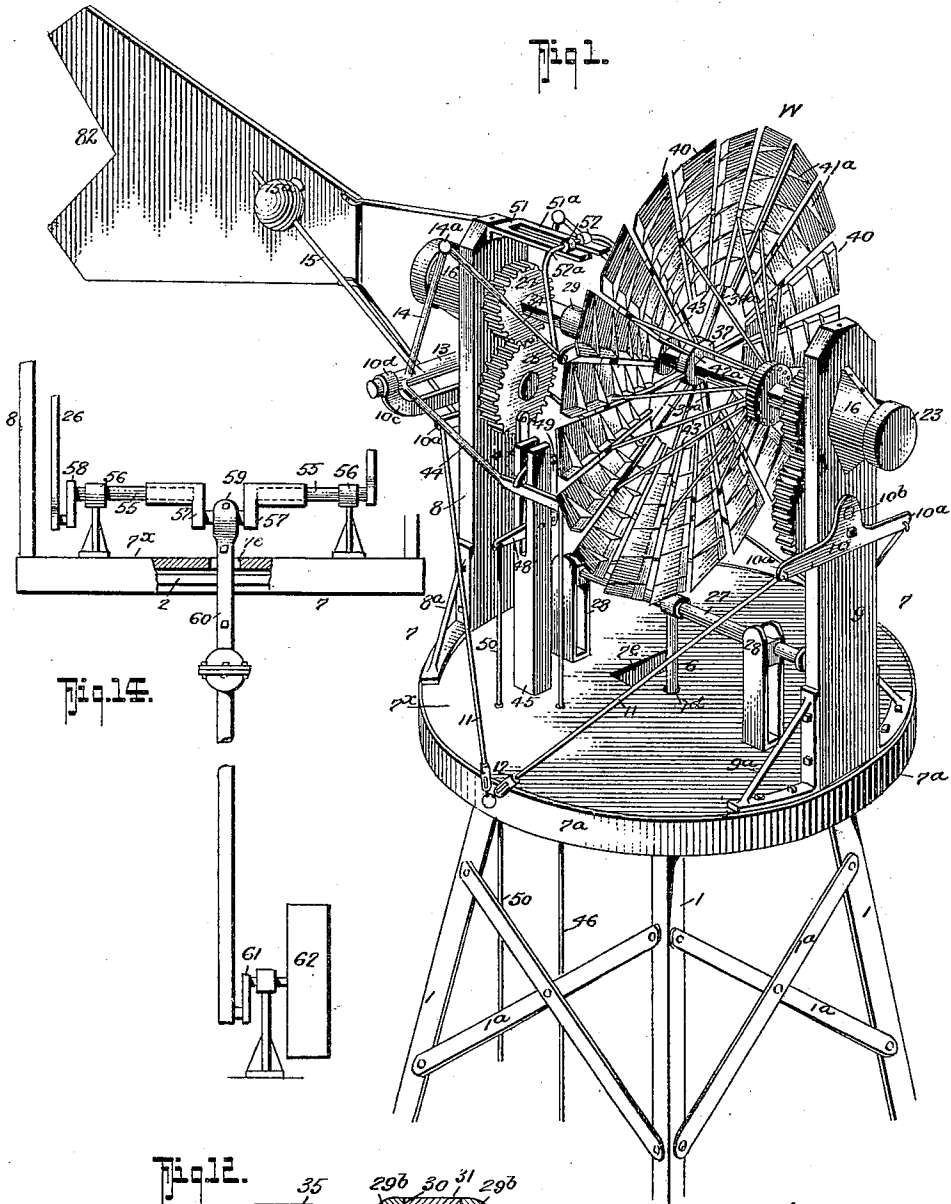

Fig. 1.

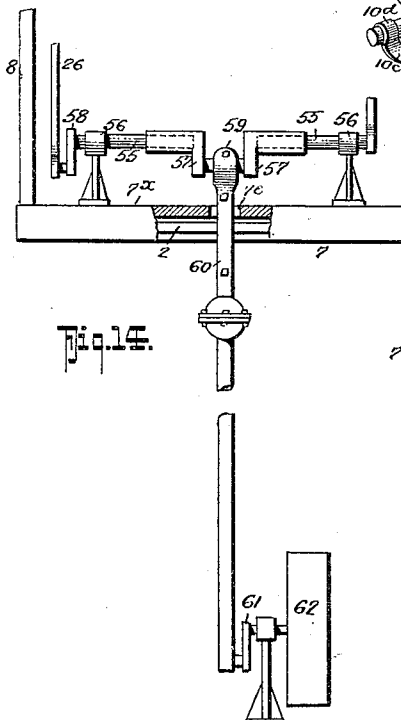

Fig. 14.

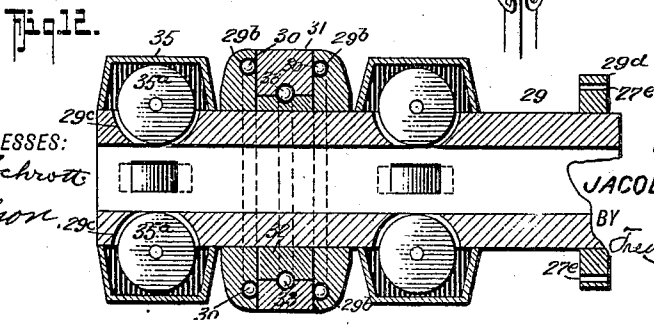

Fig. 12.

WITNESSES:
John T. Schwab
Ed. Gibson

INVENTOR
JACOB F. AYERS.
 BY *Fred & Victoria*
 ATTORNEYS

No. 838,837.

PATENTED DEC. 18, 1906.

J. F. AYERS.
WINDMILL.

APPLICATION FILED JUNE 1, 1906.

4 SHEETS—SHEET 2.

Fig. 2.

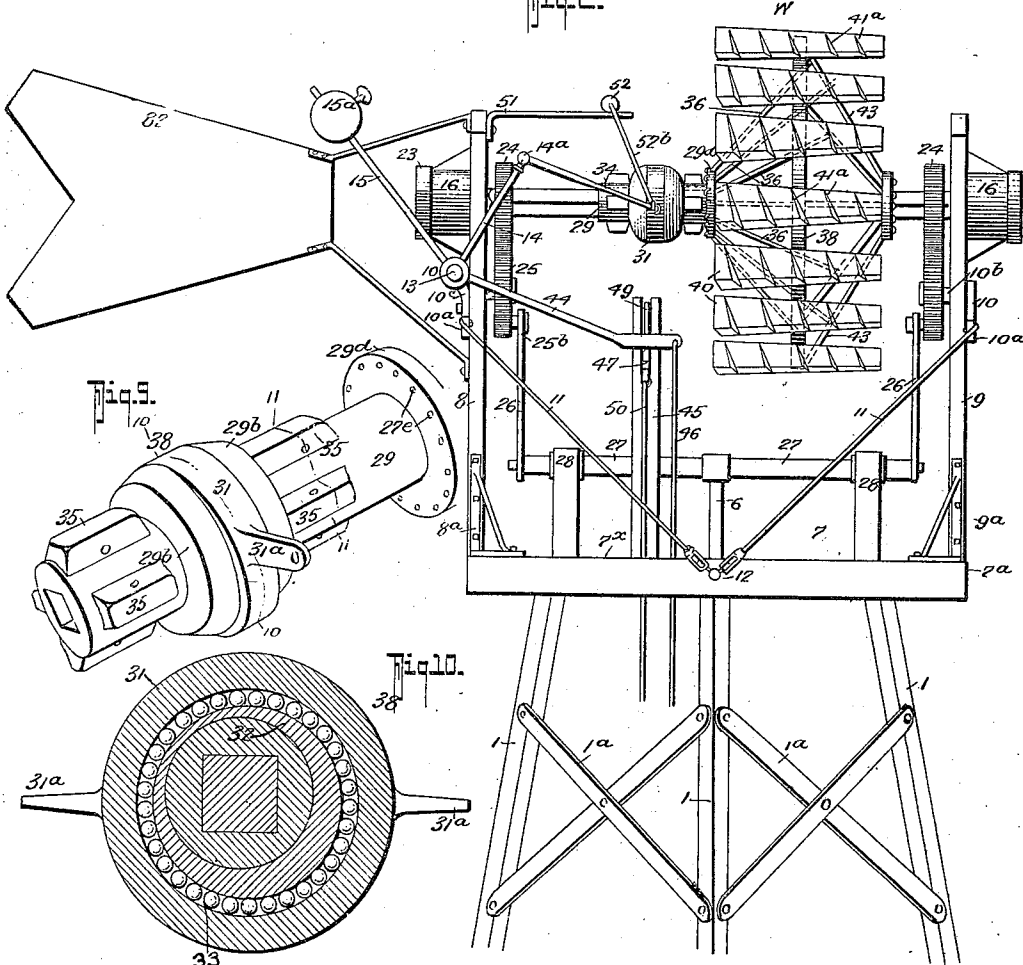

Fig. 3.

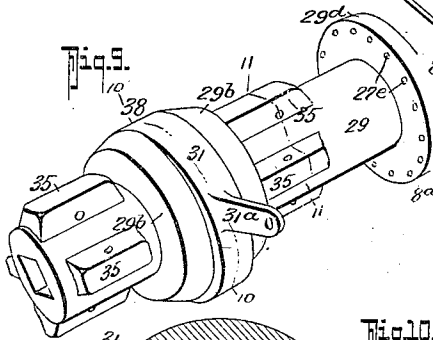

Fig. 10.

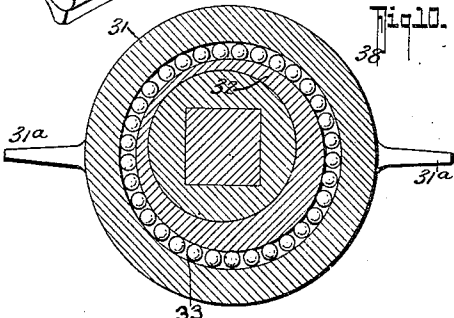

Fig. 11.

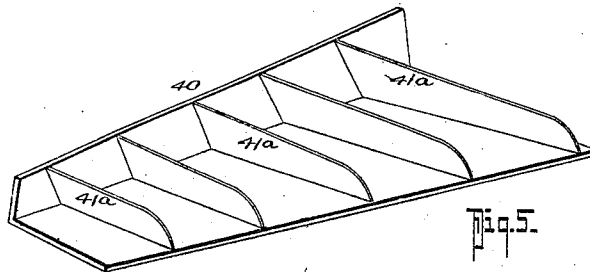
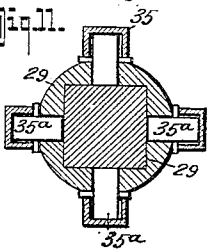

Fig. 5.

WITNESSES:
John T. Schwott,
F. L. Gibson.

INVENTOR
JACOB F. AYERS.
BY
Fred Goetters & Co.
ATTORNEYS.

No. 838,837.

PATENTED DEC. 18, 1906.

J. F. AYERS.
WINDMILL.

APPLICATION FILED JUNE 1, 1906.

4 SHEETS—SHEET 3.

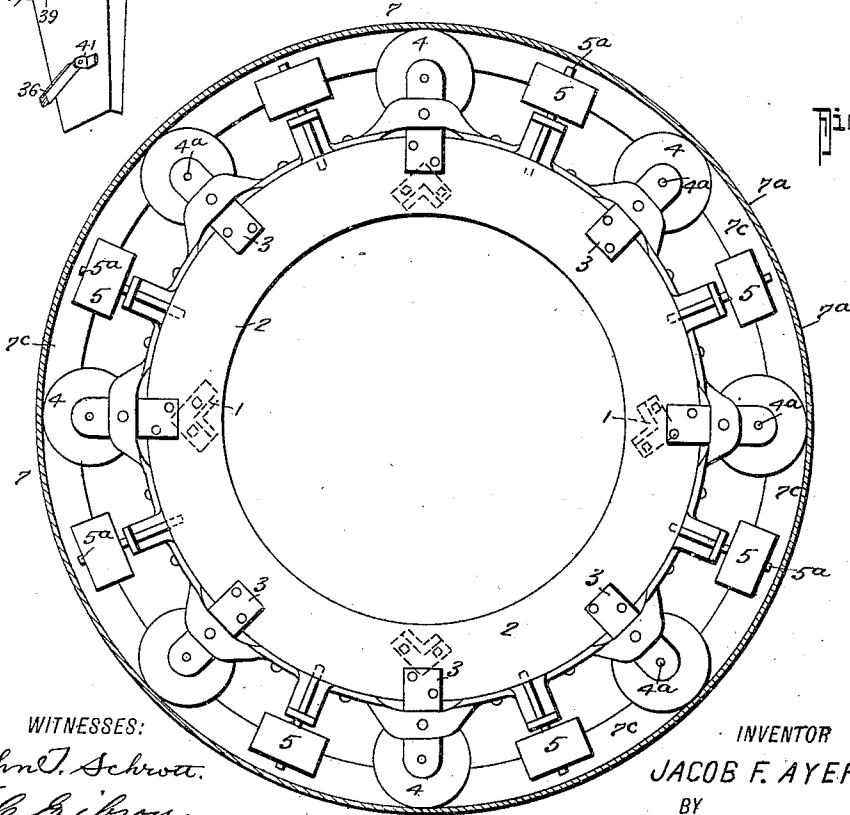
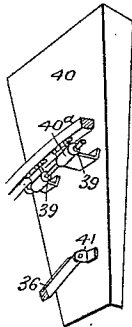
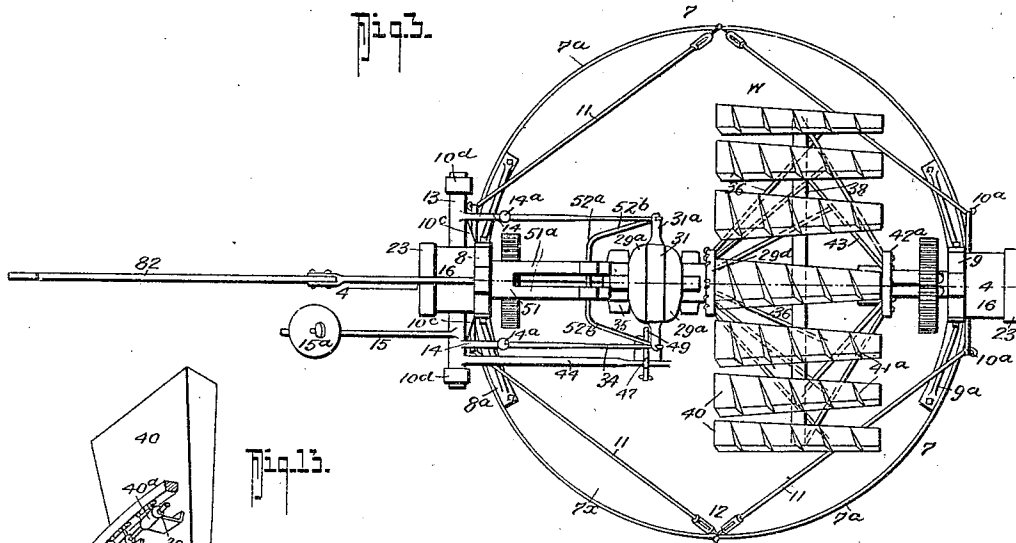

WITNESSES:
John T. Schwett.
F. C. Gibson.

INVENTOR
JACOB F. AYERS.
BY
Red L. Deterick & Co.
ATTORNEYS.

J. F. AYERS.
WINDMILL.

APPLICATION FILED JUNE 1, 1906.

4 SHEETS—SHEET 4.

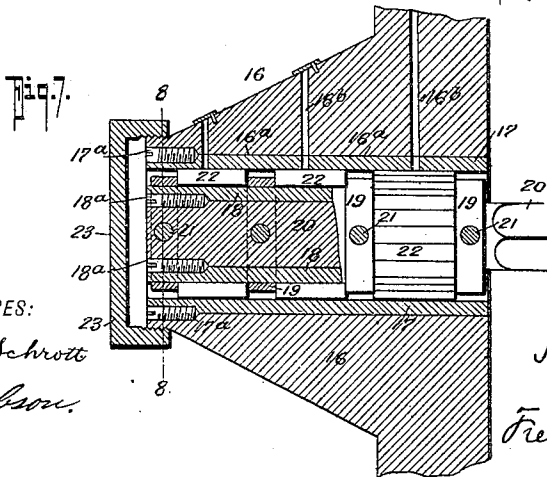
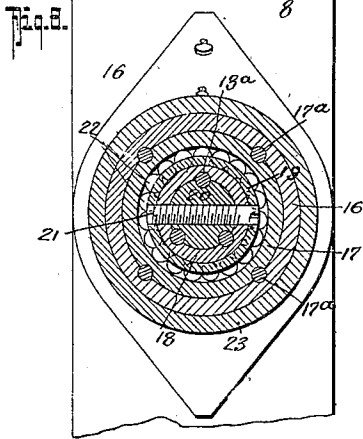
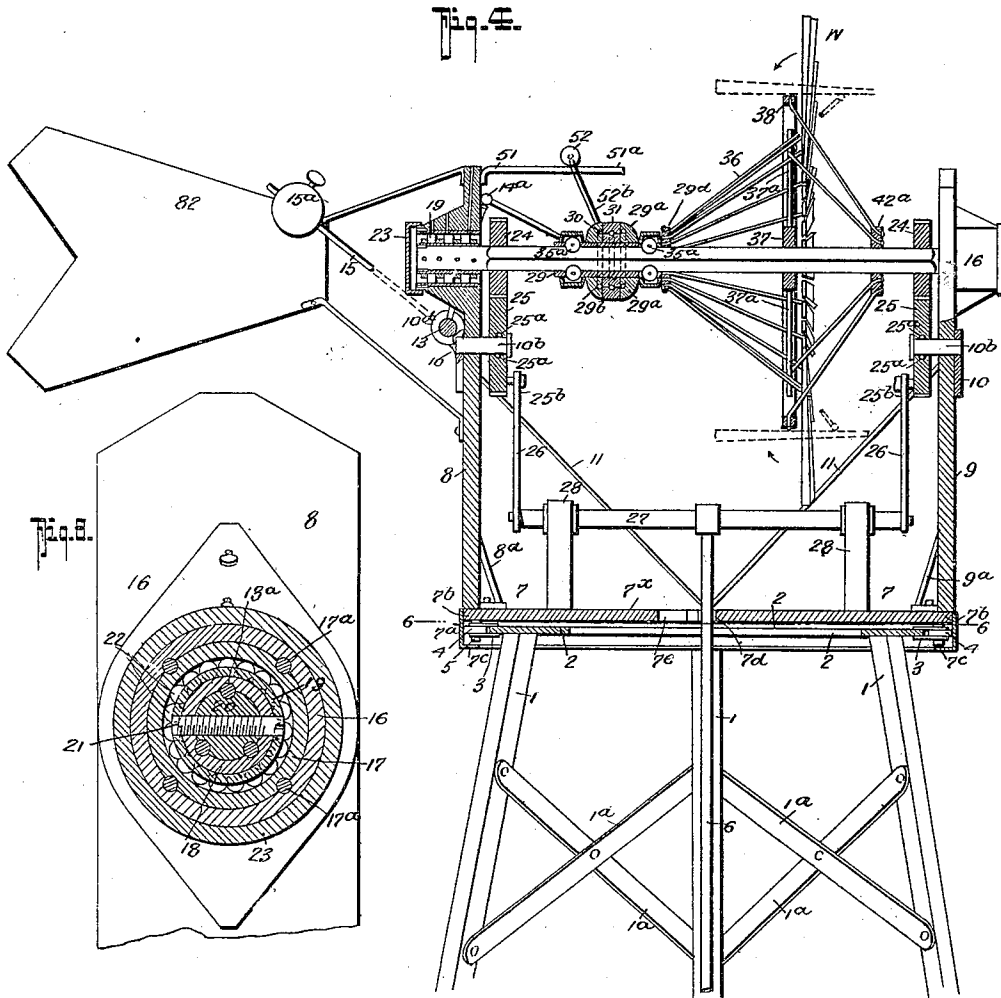

WITNESSES:

John T. Schrott
F. L. Gibson.

INVENTOR

JACOB F. AYERS.

BY

Frederick D. ...
ATTORNEYS

UNITED STATES PATENT OFFICE.

JACOB F. AYERS, OF KALKASKA, MICHIGAN.

WINDMILL.

No. 838,837.

Specification of Letters Patent.

Patented Dec. 18, 1906.

Application filed June 1, 1906. Serial No. 319,784.

To all whom it may concern:

Be it known that I, JACOB F. AYERS, residing at Kalkaska, in the county of Kalkaska and State of Michigan, have invented certain new and useful Improvements in Windmills, of which the following is a specification.

My invention relates to certain new and useful improvements in windmills, and it particularly seeks to provide a windmill in which means are provided for automatically feathering the vanes of the wind-wheel so that the windmill will be automatically controlled by the velocity of the wind.

My invention has for its object to provide a mill of this character of a very simple and effective construction which can be easily and cheaply manufactured and which will readily and effectively serve its intended purposes.

Generically, the invention includes an improved construction of turn-table, an improved construction of wind-wheel, and an improved mechanism for manually opening and closing the wind-wheel vanes, and means for mounting the wind-wheel vanes to be automatically closable by the wind-pressure as the same increases above the normal amount.

My invention also includes an improved bearing for the wind-wheel shaft and a power attachment capable of being mounted and operatively connected with the wind-wheel shaft.

With other objects in view than have heretofore been specified, the invention also includes certain novel construction, operation, and arrangement of parts, all of which will be first described in detail and then be specifically pointed out in the appended claims, reference being had to the accompanying drawings, in which—

Figure 1 is a perspective view of my invention as applied for use. Fig. 2 is a side elevation thereof. Fig. 3 is a top plan view thereof. Fig. 4 is a central vertical longitudinal section on the line 4 4 of Fig. 3. Fig. 5 is a detail perspective view of one of the wind-wheel vanes or blades. Fig. 6 is a horizontal section of the turn-table on the line 6 6 of Fig. 4. Fig. 7 is an enlarged longitudinal section of the bearing end of the wind-wheel shaft, together with its bearing in the supporting-standard. Fig. 8 is a cross-section on the line 8 8 of Fig. 7. Fig. 9 is a detail perspective of the shaft-sleeve detached from the wind-wheel shaft. Fig. 10 is a cross-section thereof on the line 10 10 of Fig. 9. Fig. 11 is

a similar view on the line 11 11 of Fig. 9. Fig. 12 is a vertical longitudinal section of the sleeve. Fig. 13 is an inverted perspective of one of the blades. Fig. 14 is a detail view of the power-mechanism attachment.

Referring now to the accompanying drawings, in which like characters of reference indicate like parts in the figures, 1 1 designate the tower-posts, which are suitably braced, as at 1^a, by cross-braces, as shown in Fig. 1 of the drawings. At the upper end of the tower I secure a platform 2, forming part of the turn-table of the mill. At suitable intervals along the periphery of the platform 2 are radially-disposed arms 3, provided with bearing portions to receive the spindles 4^a of the horizontally-held friction wheels or rollers 4, which bear against the peripheral rim 7^a of the upper or movable turn-table portion 7, hereinafter referred to. Disposed between the bearing brackets or arms 3 are friction-rollers 5, mounted on spindles 5^a, arranged in a plane at right angles to the direction of the spindle 4^a of the friction-rollers 4, so that the friction-rollers 5 will rotate at right angles to the friction-rollers 4 and will bear against the under side of the upper band portion 7^b of the movable turn-table member 7, before referred to, and to prevent the member 7 from jumping off the platform 2 I provide the rim 7^a with an inward-projecting flange 7^c, that is held under the friction-rollers 5, but out of normal engagement therewith. The bearing members 7, to which the spindles 5^a 4^a are respectively journaled, are suitably braced to the platform 2 in any approved manner. The platform 7 is provided with a central aperture 7^d to permit passage of the pump-rod 6 and an elongated slot 7^e to permit passage of the power mechanism hereinafter again referred to.

Extending upwardly from the turn-table member 7 at diametrically opposite points is a pair of vertically-disposed upright or column members 8 9, which are braced by the bracket members 8^a 9^a to the turn-table member 7, and each upright or support 8 and 9 is provided with a bearing-plate 10, securely bolted or otherwise secured to the supports 8 and 9, which bearing-plate has a pair of laterally-projecting wings 10^a, to which anchor-rods 11 11 are secured, and the anchor-rods are secured to the turntable member 7, as indicated by reference numeral 12, at diametrically-opposite points ninety degrees from the supports 8 and 9.

Each bearing-plate 10 has a spindle 10^b for a purpose presently explained. One of the plates 10 is also provided with a pair of upwardly-projecting arms 10^c, terminating in bearings 10^d to receive the oscillatable shaft 13, which carries a pair of levers 14, terminating in sockets 14^a for a purpose presently explained. An arm 15 is also secured to the shaft 13, and the arm 15 carries a counterbalanced weight 15^a for a purpose presently understood.

Each support 8 and 9 is formed with a projecting bearing-hub member 16, provided with an enlarged aperture 16^a, adapted to receive a bearing-sleeve 17, which is keyed to the hub 16 by screw-keys 17^a 17^a, as shown in Figs. 7 and 8, and the sleeves 17 cooperate with similar bearing-sleeves 18 on the mandrel or wind-wheel shaft 20, which sleeve 18 is keyed to the mandrel or shaft 20 by screw-keys 18^a, similarly to the keys 17^a for the sleeves 17. Arranged at suitable intervals on the sleeve 18 are collars 19, which are secured to the sleeves 18 and mandrel 20 by screw-bolts 21 passing therethrough. Between the collars 19 and the sleeves 17 and 18 I provide roller-bearings 22 to reduce the friction. Within the hub portion 16 are oil-channels 16^b, communicating with spaces between the collars 19 to oil the friction-rollers 22, and to prevent dust from entering the bearings I close the end of the hub 16 by a cap 23, as shown.

Adjacent each support 8 and 9 on the wind-wheel shaft 20 are driving-pinions 24, which mesh with the pinions 25, mounted on the stub-shafts 10^b and provided with anti-friction-bearings 25^a, as indicated, and each pinion 25 is provided with a crank 25^b, which is cooperatively connected with the pitmen 26, that connect with the transverse bar 27, mounted between the guide-posts 28 for movement in a vertical plane, and to which bar 27 the pump-rod 6 is secured.

Rigidly secured to the support 8 is a tail-vane 82, by means of which under control of the wind the turn-table member is revolved to bring the wind-wheel into operative relation to the wind.

Mounted on the wind-wheel shaft 20, which where it does not reside in the bearings of the posts 8 and 9 is square in cross-section, is a shifting sleeve 29, provided with hubs 29^a, spaced apart and having their adjacent faces formed with ball-races 29^b to receive the bearing-balls 30, which cooperate with the side faces of the yoke member 31, mounted on the eccentric disk 32, that is carried by the wind-wheel axle 20, and between the disk 32 and the yoke member 31 I provide ball-bearings 33, as shown. The eccentric disk 32 and the member 31, together with its connections with the arm 15 and weight 15^a, serve as a regulator for the windmill-blades, as they open and close simi-

larly to the action of a piston and dash-pot. The wheel 52 and track 51^a, together with the connecting-rods 52^b, serve to hold the disk 31 from rotating and to always keep the members 31^a horizontal. The yoke member 31 is provided with laterally-extending arms 31^a, which connect, through the connecting-rods 34, with the rods 14, hereinbefore referred to, the rods 34 having a ball to enter the socket 14^a of the rods 14 and form a ball-and-socket connection therewith. The hub 29 is of greater diameter than the greatest diameter of the shaft 20 and is provided with slotted portions 29^c, covered with a housing 35, in which is pivotally mounted friction-rollers 35^a, that ride on the shaft 20 and permit free movement of the sleeve 29 along the shaft. At one end the sleeve 29 is provided with a disk 29^d, that has radial apertures 27^e at suitable intervals apart, to which disk 29^d the wind-wheel-controlling rods 36 connect.

The wind-wheel W comprises a central disk or hub 37, secured to the shaft 20 in any approved manner, from which a series of radial arms 37^a project, and at their ends the arms 37^a are joined by a rim 38, to which at suitable intervals a U-shaped bearing-bolt 39 is secured, and upon the U-shaped bearing-arms 39 are the bearing members 40^a, secured to the back of the wind-wheel blades or vanes 40, so that the blades 40 will be capable of pivotal movement on the arms 39. Near the lower end the blades 40 are provided with bearing members 41, to which one end of the rods 36 is pivotally connected. Each blade 40 is of the form shown in detail in Figs. 5 and 13 and is provided on its front face with a plurality of baffle members 41^a, arranged to receive the wind which acts upon the same in conjunction with the body portion of the blades 40 and turns the wheel.

42^a designates a supplemental collar secured to the shaft 20, which is connected with the rim 38 of the wind-wheel W, which has stay-rods 43 to firmly hold the wind-wheel to the shaft 20.

44 designates a lever secured to the shaft 13, by means of which the shaft 13 is oscillated or rocked to cause the arms 14 to act upon the arms 34 and draw the sleeve 29 toward the post 8, and thus pull the blades in the wind-wheel 40 from a position in substantially a vertical plane to a horizontal position, as indicated in dotted lines in Fig. 4. Connected with the free end of the lever 44, which passes along the side of the post 45, secured to the upper platform 7^x, that forms a part of the turn-table member 7, is a rod or wire 46, that passes down through a suitable aperture in the platform 7^x and is under manual control.

Pivotally mounted on the support 45 is a latch member 47, that cooperates with the end of the lever 44 to hold it down when it is

not in its wheel-closing position, and the latch member 47 is automatically released through the medium of a lever 48, pivotally secured to the post 45 and connected with the latch 47 by a link 49. The lever 48 is controlled through a rod or wire 50, that passes through a suitable aperture in the turn-table platform 7^x and is manually operable.

51 designates a member secured to the post 8 at one end, which member 51 is provided with a trackway 51^a to receive a roller 52, whose spindle 52^a is connected with the arms 31^a of the yoke 31 on the sleeve 29 by stays 52^b, as indicated.

In operation the position of the various parts is that shown in Fig. 1. The wind acting upon the wind-wheel turns the shaft 20, and through the medium of the gears 24 and 25 and the pitmen 26, as well as the bar 27, the motion of the shaft 20 is converted into a reciprocating motion that is transmitted to the pump-rod 6. As the velocity of the wind increases above the maximum the wind-wheel blades will turn upon their pivots toward the position shown in full lines in Fig. 2, (their closed or inoperative position,) and thus the speed of the mill will be automatically controlled by the velocity of the wind and will always remain practically a constant. The action of the wind and the weight of the various parts of the wind-wheel is counterbalanced to a predetermined degree by the weight 15^a. The weight 15^a and its operative connections with the wind-wheel shaft, including the cam-disk 32, &c., form a governing mechanism for controlling or damping the action of the windmill-blades in opening and closing. Of course the movement of the arm 15 will be slight, as only a slight damping effect is desirable, and while it is true that the effect of the vibrations on the clutch movement would alternate a retarding effect with an accelerating effect, yet the accelerating effect which is had as the weight 15^a drops has a tendency to pull the carriage 29 from right to left in Fig. 4, and hence exert a force tending to open the blades of the windmill farther. This accelerating force while only slightly greater than the force exerted on the carriage 29 when the weight is moved upwardly thus becomes itself a retarding action in holding the blades open against the wind-pressure. In other words, the oscillation of the weight 15^a due to the action of the cam on the carriage 29 has a tendency as the weight 15^a drops slightly during the oscillation to pull the carriage 29 toward the weight, and hence exert a tension on the rods 36, which in operation tends to hold the windmill open. The weight as it is pulled up by the cam action will exert little or no effect toward moving the carriage 29 in an opposite direction, since the movement which would tend to move the carriage from left to right in Fig. 4 is taken up by the vertical move-

ment of the eccentric or cam disk. The member 51 serves to prevent the yoke 31 from rotating with the sleeve 29, which sleeve 29 rotates with the shaft 20.

In lieu of the bar 27 or in conjunction therewith, if desired, I may provide a rotatable shaft 55, mounted in bearings 56 and provided with an intermediate crank 57 and with end cranks 58, as shown in Fig. 14. The end cranks 58 connect with the pitmen 26, while the middle crank 57 connects, through the medium of the bearing-clamp 59, with the rod 60 as a ball-and-socket connection with the power-rod 60, which may be connected at its other end with the crank 61 on a band-wheel 62, from which power can be taken off.

From the foregoing description, taken in connection with the accompanying drawings, it is thought the complete construction, operation, and numerous advantages of my invention will be readily understood by those skilled in the art to which the invention appertains, and by reason of the turn-table being made of large diameter the strains on the working parts thereof, as well as on the tower, will be reduced to a minimum, and by making the wheel W with automatic controlling means operable by the wind-pressure the speed of the mill can be maintained practically constant, and the danger of having the parts blown away when used in districts susceptible of severe wind-storms is reduced to the minimum.

What I claim is—

1. The combination with a supporting-tower, of a turn-table mounted thereon, supporting-posts carried by said turn-table and having bearings, a wind-wheel shaft mounted in said bearings, a wind-wheel mounted on said shaft, said wind-wheel comprising a hub and a rim portion, and blades pivotally connected with said rim portion, and movable from a plane substantially parallel with the hub and rim portion of the wheel into planes at substantially right angles thereto, a shifting sleeve mounted on said shaft and coöperatively connected with said wheel-blades, a rock-shaft mounted in bearings on one of said supports, levers connecting said rock-shaft with said sleeve, an operating-lever connected with said rock-shaft and a weighted lever also connected with said rock-shaft, means connected to said operating-lever and projecting downwardly through the turn-table for manually controlling the operating-lever, latch devices mounted on the turn-table for holding the operating-lever in one position, manually-controlled means for releasing said latch, a pump-rod, means for transmitting the motion of the wind-wheel shaft to the pump-rod, a member provided with a trackway and secured to one of said posts, a bearing-roller operable in said trackway and coöperatively connected with

said shifting sleeve on the wheel-shaft, substantially as shown and described.

2. The combination with a wind-wheel shaft and a wind-wheel mounted thereon, comprising a hub and a rim portion, a supplemental hub mounted on the wind-wheel shaft and stay-rods connecting the supplemental hub with the rim of the wind-wheel, bracket members secured to the wind-wheel rim, blades pivotally mounted on said bracket members for movement on an axis transverse to the longitudinal axis of the blades, of a shiftable sleeve mounted on the wind-wheel shaft and coöperatively connected with the wind-wheel blades, said sleeve having apertures, roller-bearings projecting through said apertures and engaging said shaft, said sleeve having annular portions, a yoke member mounted between said annular portions on said sleeve, ball-bearings for said yoke member and means coöperatively connected with said yoke member for manually shifting the sleeve substantially as shown and described.

3. The combination with a wind-wheel shaft and a wind-wheel mounted thereon, comprising a hub and a rim portion, a supplemental hub mounted on the wind-wheel shaft and stay-rods connecting the supplemental hub with the rim of the wind-wheel, bracket members secured to the wind-wheel rim, blades pivotally mounted on said bracket members for movement on an axis transverse to the longitudinal axis of the blades, of a shiftable sleeve mounted on the wind-wheel shaft and coöperatively connected with the wind-wheel blades, said sleeve having apertures, roller-bearings projecting through the apertures and engaging said shaft, said sleeve having annular portions, a yoke member mounted between said annular portions on said sleeve, ball-bearings for said yoke member, means coöperatively connected with said yoke member for manually shifting the sleeve, said last-named means comprising a rock-shaft, arms projecting from said rock-shaft, connections between said arms and said yoke member, a lever connected with said rock-shaft, and a rod or wire connected with said lever and adapted to be grasped by the operator.

4. The combination with a wind-wheel shaft and a wind-wheel mounted thereon, comprising a hub and a rim portion, a supplemental hub mounted on the wind-wheel shaft and stay-rods connecting the supplemental hub with the rim of the wind-wheel, bracket members secured to the wind-wheel rim, blades pivotally mounted on said bracket members for movement on an axis transverse to the longitudinal axis of the blades, of a shiftable sleeve mounted on the wind-wheel shaft and coöperatively connected with the wind-wheel blades, said sleeve having apertures, roller-bearings pro-

jecting through said apertures and engaging said shaft, said sleeve having annular portions, a yoke member mounted between said annular portions on said sleeve, ball-bearings for said yoke member, means coöperatively connected with said yoke member for manually shifting the sleeve, said last-named means comprising a rock-shaft, arms projecting from said rock-shaft, connections between said arms and said yoke member, a lever connected with said rock-shaft, a rod or wire connected with said lever and adapted to be grasped by the operator, and means for locking said last-named lever, in one position, substantially as shown and described.

5. The combination with a wind-wheel shaft and a wind-wheel mounted thereon, comprising a hub and a rim portion, a supplemental hub mounted on the wind-wheel shaft and stay-rods connecting the supplemental hub with the rim of the wind-wheel, bracket members secured to the wind-wheel rim, blades pivotally mounted on said bracket members for movement on an axis transverse to the longitudinal axis of the blades, of a shiftable sleeve mounted on the wind-wheel shaft and coöperatively connected with the wind-wheel blades, said sleeve having apertures, roller-bearings projecting through said apertures and engaging said shaft, said sleeve having annular portions, a yoke member mounted between said annular portions on said sleeve, ball-bearings for said yoke member, means coöperatively connected with said yoke member for manually shifting the sleeve, said last-named means comprising a rock-shaft, arms projecting from said rock-shaft, connections between said arms and said yoke member, a lever connected with said rock-shaft, a rod or wire connected with said lever and adapted to be grasped by the operator, and means for locking said last-named lever, and manually-controlled means for releasing said locking means, substantially as shown and described.

6. The combination with a wind-wheel shaft and a wind-wheel mounted thereon, comprising a hub and a rim portion, a supplemental hub mounted on the wind-wheel shaft and stay-rods connecting the supplemental hub with the rim of the wind-wheel, bracket members secured to the wind-wheel rim, blades pivotally mounted on said bracket members for movement on an axis transverse to the longitudinal axis of the blades, of a shiftable sleeve mounted on the wind-wheel shaft and coöperatively connected with the wind-wheel blades, said sleeve having apertures, roller-bearings projecting through said apertures and engaging said shaft, said sleeve having annular portions, a yoke member mounted between said annular portions on said sleeve, ball-bearings for said yoke member, means coöperatively connected with said yoke member for manually

shifting the sleeve and counterbalancing means for normally holding the sleeve in one position on the shaft, substantially as shown and described.

5 7. The combination with a wind-wheel shaft and a wind-wheel mounted thereon comprising a hub and a rim portion, a supplemental hub mounted on the wind-wheel shaft and stay-rods connecting said supplemental hub with the rim of the wind-wheel
10 bracket members secured to the wind-wheel rim, blades pivotally mounted on said bracket members for movement on an axis transverse to the longitudinal axis of the
15 blades, of a shiftable sleeve mounted on the wind-wheel shaft and coöperatively connected with the wind-wheel blades, said sleeve having apertures, roller-bearings projecting through said apertures and engaging said
20 shaft, said sleeve having annular portions, a yoke member mounted between said annular portions on said sleeve, ball-bearings for said yoke member, means coöperatively connected with said yoke member for manually
25 shifting the sleeve, said last-named means comprising a rock-shaft, arms projecting from said rock-shaft, connections between said arms and said yoke member, a lever connected with said rock-shaft, and a rod or wire
30 connected with said lever and adapted to be grasped by the operator and counterbalancing means for normally holding the sleeve in one position on the shaft, substantially as shown and described.

35 8. The combination with a wind-wheel shaft and a wind-wheel mounted thereon comprising a hub and a rim portion, a supplemental hub mounted on the wind-wheel shaft and stay-rods connecting the supplemental hub with the rim of the wind-wheel
40 bracket members secured to the wind-wheel rim, blades pivotally mounted on said bracket members for movement on an axis transverse to the longitudinal axis of the blades, of a shiftable sleeve mounted on the wind-wheel shaft and coöperatively connected with the wind-wheel blades, said sleeve having apertures, roller-bearings projecting through said apertures and engaging said
50 shaft, said sleeve having annular portions, a yoke member mounted between said annular portions on said sleeve, ball-bearings for said yoke member, means coöperatively connected with said yoke member for manually
55 shifting the sleeve, said last-named means comprising a rock-shaft, arms projecting from said rock-shaft, connections between said arms and said yoke member, a lever connected with said rock-shaft, a rod or wire connected with said lever and adapted to be grasped by the operator, counterbalancing means for normally holding the sleeve in one position on the shaft, said counterbalancing means comprising a rod secured to said rock-
65 shaft and a weight adjustably held on said

rock-shaft, substantially as shown and described.

9. The combination with a wind-wheel shaft and a wind-wheel mounted thereon comprising a hub and a rim portion, a supplemental hub mounted on the wind-wheel shaft, and stay-rods connecting the supplemental hub with the rim of the wind-wheel, bracket members secured to the wind-wheel rim, blades pivotally mounted on said
70 bracket members for movement on an axis transverse to the longitudinal axis of the blades, of a shiftable sleeve mounted on the wind-wheel shaft and coöperatively connected with the wind-wheel blades, said
75 sleeve having apertures, roller-bearings projecting through said apertures and engaging said shaft, said sleeve having annular portions, a yoke member mounted between said annular portions on said sleeve, ball-bearings for said yoke member, means coöperatively connected with said yoke member for manually shifting the sleeve, a pump-rod, means coöperatively connecting the pump-rod with the wind-wheel shaft whereby the
80 movement of the wind-wheel shaft is transmitted to the pump-rod substantially as shown and described.

10. The combination with a wind-wheel shaft and a wind-wheel mounted thereon
95 comprising a hub and a rim portion, a supplemental hub mounted on the wind-wheel shaft and stay-rods connecting the supplemental hub with the rim of the wind-wheel, bracket members secured to the wind-wheel
100 rim, blades pivotally mounted on said bracket members for movement on an axis transverse to the longitudinal axis of the blades, of a shiftable sleeve mounted on the wind-wheel shaft and coöperatively connected with the wind-wheel blades, said
105 sleeve having apertures, roller-bearings projecting through said apertures and engaging said shaft, said sleeve having annular portions, a yoke member mounted between said annular portions on said sleeve, ball-bearings for said yoke member, means coöperatively connected with said yoke member for manually shifting the sleeve, said last-named
110 means comprising a rock-shaft, arms projecting from said rock-shaft, connections between said arms and said yoke member, a lever connected with said rock-shaft, a rod or wire connected with said lever and adapted to be grasped by the operator, counterbalancing means for normally holding the sleeve in one position on the shaft, a pump-rod, means coöperatively connecting the pump-rod with the wind-wheel shaft whereby the
115 movement of the wind-wheel shaft is transmitted to the pump-rod, substantially as shown and described.

11. The combination with a wind-wheel shaft and a wind-wheel mounted thereon comprising a hub and a rim portion, a sup-
130

plemental hub mounted on the wind-wheel shaft and stay-rods connecting the supplemental hub with the rim of the wind-wheel, bracket members secured to the wind-wheel rim, blades pivotally mounted on said bracket members for movement on an axis transverse to the longitudinal axis of the blades, of a shiftable sleeve mounted on the wind-wheel shaft and cooperatively connected with the wind-wheel blades, said sleeve having apertures, roller-bearings projecting through said apertures and engaging said shaft, said sleeve having annular portions, a yoke member mounted between said annular portions on said sleeve, ball-bearings for said yoke member, means cooperatively connected with said yoke member for manually shifting the sleeve, said last-named means comprising a rock-shaft, arms projecting from said rock-shaft, connections between said arms and said yoke member, a lever connected with said rock-shaft, a rod or wire connected with said lever and adapted to be grasped by the operator, counterbalancing means for normally holding the sleeve in one position on the shaft, said counterbalancing means comprising a rod secured to said rock-shaft and a weight adjustably held on said rock-shaft, a pump-rod, means cooperatively connecting the pump-rod with the wind-wheel shaft whereby the movement of the wind-wheel shaft is transmitted to the pump-rod, substantially as shown and described.

12. In a windmill, the combination with a tower, a turn-table mounted thereon, upright supports secured to said turn-table and having bearing portions, a wind-wheel shaft mounted in said bearing portions, said bearing portions and said wind-wheel shaft having cooperating antifriction-bearings, antifriction-bearings for said turn-table, a tail-vane secured to one of said upright supports, a rock-shaft carried by one of said upright supports, a shaft-sleeve on said wind-wheel shaft, roller-bearings for said shifting sleeve, a yoke member cooperating with said shifting sleeve, connections between said rock-shaft and said yoke member for transmitting the motion of the rock-shaft to the sleeve, counterbalancing means cooperatively connected with the rock-shaft, an operating-lever connected with the rock-shaft, means for operating said operating-lever from below the turn-table, a wind-wheel mounted on said wind-wheel shaft, said wind-wheel comprising hub and rim portions and pivotally-mounted vanes, means cooperatively connecting said vanes with said sleeve, pinions mounted on said upright supports, antifriction-bearings for said pinions, pinions carried by said wind-wheel shaft for meshing with said first-mentioned pinions, said first-mentioned pinions having cranks, pitmen connected with said cranks, a power-rod, means cooperatively

connecting said pitmen with said power-rod, substantially as shown and described.

13. In a windmill, the combination with a tower, a turn-table, mounted thereon, upright supports secured to said turn-table and having bearing portions, a wind-wheel shaft mounted in said bearing portions, said bearing portions and said wind-wheel shaft having cooperating antifriction-bearings, antifriction-bearings for said turn-table, a tail-vane secured to one of said upright supports, a rock-shaft carried by one of said upright supports, a shifting sleeve on said wind-wheel shaft, roller-bearings for said shifting sleeve, a yoke member cooperating with said shifting sleeve, connections between said rock-shaft and said yoke member for transmitting the motion of the rock-shaft to the sleeve, counterbalancing means cooperatively connected with the rock-shaft, an operating-lever connected with the rock-shaft, means for operating said operating-lever from below the turn-table, a wind-wheel mounted on said wind-wheel shaft, said wind-wheel comprising hub and rim portions and pivotally-mounted vanes, means cooperatively connecting said vanes with said sleeve, pinions mounted on said upright supports, antifriction-bearings for said pinions, pinions carried by said wind-wheel shaft for meshing with said first-mentioned pinions, said first-mentioned pinions having cranks, pitmen connected with said cranks, a power-rod, means cooperatively connecting said pitmen with said power-rod a pivot member connected with one of said upright supports, a guide-roller carried by said yoke member for cooperating with said pivot member, substantially as shown and described.

14. In a windmill, the combination with a tower, a turn-table mounted thereon, upright supports secured to said turn-table and having bearing portions, a wind-wheel shaft mounted in said bearing portions, said bearing portions and said wind-wheel shaft having cooperating antifriction-bearings, antifriction-bearings for said turn-table, a tail-vane secured to one of said upright supports, a rock-shaft carried by one of said upright supports, a shifting sleeve on said wind-wheel shaft, roller-bearings for said shifting sleeve, a yoke member cooperating with said shifting sleeve, connections between said rock-shaft and said yoke member for transmitting the motion of the rock-shaft to the sleeve, counterbalancing means cooperatively connected with the rock-shaft, an operating-lever connected with the rock-shaft, means for operating said operating-lever from below the turn-table, a wind-wheel mounted on said wind-wheel shaft, said wind-wheel comprising hub and rim portions and pivotally-mounted vanes, means cooperatively connecting said vanes with said sleeve, pinions mounted on said upright supports, an-

friction-bearings for said pinions, pinions carried by said wind-wheel shaft for meshing with said first-mentioned pinions, said first-mentioned pinions having cranks, pitmen
5 connected with said cranks, a power-rod, means coöperatively connecting said pitmen with said power-rod, a pivot member connected with one of said upright supports, a guide-roller carried by said yoke member for
coöperating with said pivot member, and 10 means for locking the operating-lever of the rock-shaft at times, and manually-controlled means for releasing said locking means, substantially as shown and described.

JACOB F. AYERS.

Witnesses:

Mrs. L. E. DAVIS,
ALICE BLODGETT.