

(19) World Intellectual Property Organization
International Bureau



(43) International Publication Date
10 December 2009 (10.12.2009)

(10) International Publication Number
WO 2009/147657 A2

- (51) International Patent Classification:
F21V 1/06 (2006.01) F21V 1/26 (2006.01)
F21V 17/06 (2006.01)
- (21) International Application Number:
PCT/IL2009/000518
- (22) International Filing Date:
26 May 2009 (26.05.2009)
- (25) Filing Language: English
- (26) Publication Language: English
- (30) Priority Data:
191857 1 June 2008 (01.06.2008) IL
- (71) Applicant and
(72) Inventor: NIDAN, Sammy [IL/IL]; Pob. 4119, Hayasim
22 St., Kadima 60920 (IL).
- (81) Designated States (unless otherwise indicated, for every
kind of national protection available): AE, AG, AL, AM,
AO, AT, AU, AZ, BA, BB, BG, BH, BR, BW, BY, BZ,
CA, CH, CN, CO, CR, CU, CZ, DE, DK, DM, DO, DZ,

EC, EE, EG, ES, FI, GB, GD, GE, GH, GM, GT, HN,
HR, HU, ID, IL, IN, IS, JP, KE, KG, KM, KN, KP, KR,
KZ, LA, LC, LK, LR, LS, LT, LU, LY, MA, MD, ME,
MG, MK, MN, MW, MX, MY, MZ, NA, NG, NI, NO,
NZ, OM, PG, PH, PL, PT, RO, RS, RU, SC, SD, SE, SG,
SK, SL, SM, ST, SV, SY, TJ, TM, TN, TR, TT, TZ, UA,
UG, US, UZ, VC, VN, ZA, ZM, ZW.

(84) Designated States (unless otherwise indicated, for every
kind of regional protection available): ARIPO (BW, GH,
GM, KE, LS, MW, MZ, NA, SD, SL, SZ, TZ, UG, ZM,
ZW), Eurasian (AM, AZ, BY, KG, KZ, MD, RU, TJ,
TM), European (AT, BE, BG, CH, CY, CZ, DE, DK, EE,
ES, FI, FR, GB, GR, HR, HU, IE, IS, IT, LT, LU, LV,
MC, MK, MT, NL, NO, PL, PT, RO, SE, SI, SK, TR),
OAPI (BF, BJ, CF, CG, CI, CM, GA, GN, GQ, GW, ML,
MR, NE, SN, TD, TG).

Published:

— without international search report and to be republished
upon receipt of that report (Rule 48.2(g))

(54) Title: LAMPSHADE

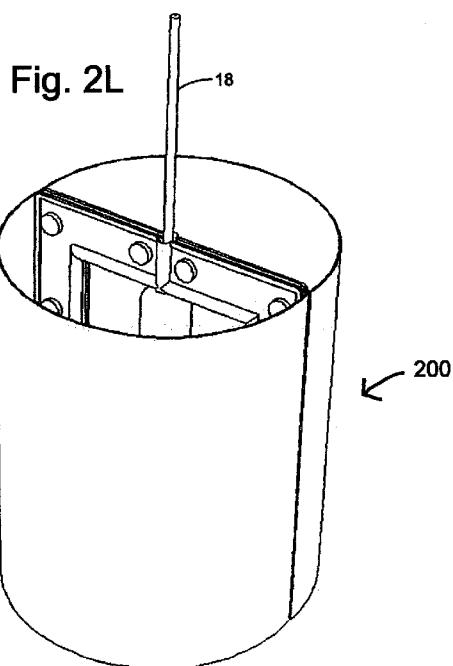

(57) Abstract: Foldable lampshade or lamp base adaptable for inexpensive mass production and configured for easy assembly without having to remove the lamp socket. The frame part comprises a pair of connected or separate complementary sections, substantially shaped as a mirror image of each other. The sheet-like part is a sheet or foil, optionally having concave and/or convex relief shapes and/or notched curves as ornaments, or folding aids, or mechanical connections elements or other structures such as cutouts. Embodiments, the at least one sheet-like part comprises a plurality of connected or separate sheets, such as a pair of parts. The sheet-like part, or parts thereof, is adapted for forming a circular or partly-circular contour, or other shape, on the frame and/or around the lamp. In some embodiments of the invention, the lampshade and lamp base are assembled (constructed) by folding the parts and connecting them by fasteners that are integrally formed with or attached to the parts that comprise the lampshade or lamp base (either on the flexible sheet parts and/or the frame part). Preferably, without limiting, the lampshade and lamp base may be assembled and disassembled without removing the lamp socket or bulb and without any tools by a person with no particular skill. For example, the assembly is carried out by interlocking elements shaped like snap fasteners or by hook and loop fasteners. In some embodiments, the fasteners are integral with the lampshade or lamp base, while in other embodiments the fasteners are attached to the lampshade or lamp base. In some embodiments of the invention, the frame part and/or sheet-like part are made of, or comprise, polymeric materials, by vacuum forming or cold forming. Optionally or alternatively, other fabrication methods are used, such as injection or molding. In an opened (unassembled) position, the lampshade and lamp base parts are substantially flat, requiring negligible storage space.

WO 2009/147657 A2

LAMPSHADE

FIELD OF THE INVENTION

The present invention relates to lampshades. Some embodiments of the
5 invention relate to foldable lampshades.

BACKGROUND OF THE INVENTION

Conventional lampshades, such as used for ceiling lamps, typically
comprise a metallic structure of rods or wires, a ring mounted around the lamp
10 wire and a shade, such as a cloth or paper, disposed on the metallic structure.
Such lampshades require the removal of the lamp bulb and the bulb socket in
order to allow the wire to enter through the ring.

Some designs enable installing a lampshade without removing the bulb or
socket. For example, US patent 2,435,759 relates to a structure with a ring having
15 a slit so that the lamp wire can enter the ring via the slit. Another example is US
patent 1,309,263 that relates to a single piece foldable sheet which is wrapped
above and around the lamp to form a truncated cone shape.

The disclosures of the cited art are fully incorporated herein by reference.

20 SUMMARY OF THE INVENTION

According to a general aspect of the invention, there is provided a foldable
lampshade or lamp base adaptable for inexpensive mass production and
configured for easy assembly without having to remove the lamp socket or bulb.

According to an aspect of the invention there is provided a foldable
25 lampshade comprising a stiffened frame made of at least one thin-walled part,
and at least one flexible sheet-like part mounted on the frame.

According to another aspect of the invention there is provided a foldable
lamp base comprising a stiffened frame made of at least one thin-walled part, and
at least one flexible sheet-like part mounted on the frame.

30 The thin-walled part is a part substantially having a thickness considerably
smaller than any extent vertical to the thickness. For example, a thin sheet

formed with relief structures and/or bends that provide stiffness to the frame. The stiffened frame may still be resilient and/or flexible to some extent to allow temporary bending under some force.

In some embodiments of the invention, the frame part comprises a pair of
5 connected or separate complementary sections, substantially shaped as a mirror image of each other.

In some embodiments of the invention, the sheet-like part is a sheet or foil, optionally having concave and/or convex relief shapes and/or notched curves as ornaments, or folding aids, or mechanical connections elements or other
10 structures such as cutouts. In some embodiments, the at least one sheet-like part comprises a plurality of connected or separate sheets, such as a pair of parts.

The sheet-like part, or parts thereof, is adapted for forming a circular or partly-circular contour, or other shape, on the frame and/or around the lamp.

In some embodiments of the invention, the lampshade and lamp base are
15 assembled (constructed) by folding the parts and connecting them by fasteners that are integrally formed with or attached to the parts that comprise the lampshade or lamp base (either on the flexible sheet parts and/or the frame part). Preferably, without limiting, the lampshade and lamp base may be assembled and disassembled without removing the lamp socket or bulb and without any tools by
20 a person with no particular skill. For example, the assembly is carried out by interlocking elements shaped like snap fasteners or by hook and loop fasteners. In some embodiments, the fasteners are integral with the lampshade or lamp base, while in other embodiments the fasteners are attached to the lampshade or lamp base.

25 In some embodiments of the invention, the frame part and/or sheet-like part are made of, or comprise, polymeric materials, optionally with additives. Optionally or alternatively, the frame part comprises metal or other materials.

In some embodiments of the invention, the frame part and/or sheet-like part are formed from a sheet or foil, such as plastic sheet, by vacuum forming or
30 cold forming. Optionally or alternatively, other fabrication methods are used, such as injection or molding.

In an opened (unassembled) position, the lampshade and lamp base parts are substantially flat, requiring negligible storage space.

In the specification and claims, unless otherwise specified, the term 'fastener' denotes any element, structure or material capable or configured to connect at least two parts. In this respect a fastener may comprise an element, structure or material capable or configured to connect to a corresponding element, structure or material. For example, projection-recess, projection-hole, hooks-loops, slit-slit, magnet-magnet, magnet-ferromagnetic material, or, for example, an adhesive or glue.

According to an aspect of some embodiments of the present invention there is provide a foldable lampshade, comprising:

(a) a stiffened frame made of at least one thin-walled part defining a space therein in which a lamp bulb can be disposed and defining a hollow for mounting on a lamp component; and

(b) at least one flexible sheet-like part mounted on the frame for shading the lamp bulb.

In some embodiments, the frame is stiffened by structures comprised in the thin-walled part.

In some embodiments of the invention, the structures comprise at least one of relief structures or bends.

In some embodiments of the invention, the frame is resilient.

In some embodiments of the invention, the frame comprises two sections foldable along a folding groove therebetween.

In some embodiments of the invention, the frame sections comprise relief structures that that fit, at least partly, a hanging lamp electrical wire or a standing lamp pole.

In some embodiments of the invention, the frame sections complement each other to form at least one hollow to fit on at least one component of the lamp.

In some embodiments of the invention, the frame comprises at least one fastener configured to attach at least the sections thereof.

In some embodiments of the invention, the at least one fastener is an integral part of the frame.

In some embodiments of the invention, at least one fastener is attached to the frame.

5 In some embodiments of the invention, the at least one flexible sheet-like part comprises a plurality of sheet-like parts.

In some embodiments of the invention, the at least one flexible sheet-like part connects by at least one edge thereof to the frame as an integral part.

10 In some embodiments of the invention, the at least one flexible sheet-like part connects by at least one edge region thereof to the frame by at least one fastener.

In some embodiments of the invention, at least two parts of the flexible sheet-like parts connect to each other by at least one fastener.

15 In some embodiments of the invention, the lampshade is assembled by folding parts thereof.

In some embodiments of the invention, the lampshade is disassembled by unfolding parts thereof.

In some embodiments of the invention, at least one of the frame or flexible sheets comprises a polymeric material.

20 In some embodiments of the invention, at least one of the frame or flexible sheets are adaptable for fabrication from a sheet or foil.

In some embodiments of the invention, the lampshade parts are configured to open separately into a substantially flat form.

25 In some embodiments of the invention, the lampshade parts are configured for construction without tools.

In some embodiments of the invention, the lampshade is configured for mounting on a lamp wire or pole while maintaining the lamp socket connected to an electrical wire.

30 In some embodiments of the invention, the lampshade is configured for mounting on a lamp wire or pole while maintaining the light bulb within the lamp socket.

In some embodiments of the invention, the lampshade is configured for construction as a lamp stand in which a lamp socket is mounted on the frame.

According to another aspect of some embodiments of the present invention there is provide a foldable lamp stand, comprising:

5 (a) a stiffened frame made of at least one thin-walled part defining a space therein which a lamp bulb can be disposed and defining a hollow for mounting on a lamp component; and

(b) at least one flexible sheet-like part mounted on the frame for shading the lamp bulb.

10

BRIEF DESCRIPTION OF THE DRAWINGS

The invention may be understood upon reading of the following detailed description of non-limiting an exemplary embodiments thereof, with reference to the following drawings.

15

Identical or duplicate or equivalent or similar structures, elements, or parts that appear in more than one drawing are generally labeled with the same reference numeral. Dimensions of components and features shown in the figures are chosen for convenience or clarity of presentation and are not necessarily shown to scale or true perspective. For clarity, some structures are not shown or shown only partially, or without perspective, and duplicate or equivalent or similar parts may not be repeatedly labeled.

20

Fig. 1A shows a lampshade comprising a single part in an open position, according to an exemplary embodiment of the invention;

25

Figs. 1B to 1G show the sequential stages of constructing the lampshade of **Fig. 1A** on a lamp;

Fig. 1H shows a partially cut view of the lampshade of **Fig. 1A** constructed on a lamp;

Fig. 2A shows an open position of a frame part of a 3-part lampshade, according to an exemplary embodiment of the invention;

30

Fig. 2B shows an open position of two flexible sheet parts of a 3-part lampshade, according to an exemplary embodiment of the invention;

Figs. 2C to 2H show the sequential stages of constructing on a lamp the 3-part lampshade, comprising the parts of **Figs. 2A to 2B**, according to an exemplary embodiment of the invention;

Fig. 3A shows a partially folded position of a frame part of a 3-part lampshade, similar to that of **Fig. 2A**, according to an exemplary embodiment of the invention;

Figs. 3B to 3D show sequential stages of constructing a 3-part lampshade, comprising parts similar to those of **Figs 2A to 2B**, according to an exemplary embodiment of the invention;

Figs. 4A to 4C show a 3-part lampshade, similar to the lampshade respective to **Figs. 2C to 2L** disposed on a standing lamp (rather than a hanging lamp), according to an exemplary embodiment of the invention;

Fig. 5A shows an open position of two pairs of flexible sheet parts of a lampshade, according to an exemplary embodiment of the invention;

Figs. 5B to 5C show the sequential stages of constructing a lampshade, comprising the parts of **Fig. 5A** and a frame similar to that of **Fig. 2A**, according to an exemplary embodiment of the invention;

Figs. 6A to 6D show sequential stages of constructing a lampshade, comprising four flexible sheet parts and a frame similar to that of **Fig. 2A**, according to an exemplary embodiment of the invention;

Fig. 7A shows a partial stage of constructing a lamp stand, similar to constructing a lampshade such as of **Figs. 2C to 2H**, according to an exemplary embodiment of the invention; and

Figs. 7B to 7C show two variants of a lamp base, according to an exemplary embodiment of the invention.

DESCRIPTION OF EMBODIMENTS OF THE INVENTION

The following description relates to some non-limiting examples of embodiments of the invention.

The non-limiting section headings used herein are intended for convenience only and are not necessarily limiting the scope of the invention.

Sample embodiment 1

Fig. 1A shows a lampshade **100** comprising a single thin walled part in an open position. Lampshade **100**, excluding connectors **13** and **14** (discussed below), is made of two substantially mirror-image complementary parts, **Side A** and **Side B**. Each side comprises two parts, divided by a folding groove **15b**, as follows:

(i) a frame part **12a** and **12b** having relief structures **16a**, **16b**, **11a**, and **11b** that provide stiffness to the part, some of which are formed in the shape corresponding to a lamp socket and passage for a wire (e.g. **11a** and **11b**) to fit accordingly on a lamp, and (ii) a flexible sheet part **10a** and **10b** for providing the shade from a light bulb.

Lampshade **100** has folding grooves **15a**, **15b**, **15d** and **15e** and a cut **15c** for folding part **100** into a lampshade around and over a lamp wire and socket and optionally around a lamp bulb, where projections **13** and recesses **14** in strips **9a** and **9b** are used to lock the folds.

With reference to **Figs. 1B-1H**, lampshade **100** is constructed by attaching the respective relief structures such as **11a** and **11b** of one (first) side (**Side A** or **Side B**) on a lamp wire (or wires) and on a lamp socket and folding the opposite (second) side to face the first side and locking projections **13** into recesses **14**. Next, strips **9a** and **9b** of each side are folded vertically to the surface of flexible sheet **10a** and **10b**, respectively, and sheets **10a** and **10b** (which are separated by cut **15c**) are curved around the lamp socket (and optional bulb) and attach to frame part **12a** and **12b** by projections **13** and recesses **14** on strips **9a** and **9b**. It should be noted that projections **13** form on their opposite side recesses for other projections so that, for example, projections **13** on strip **9b** insert into recesses **14** which is the opposite side on projections **13** of frame part **12b**.

Fig. 1B shows lampshade **100** with relief structure **11a** (**Side A**) of frame part **12a** attached to electrical a wire (or wires) **18** connected to a lamp socket **17** with a bulb **19**, where lampshade part **100** is partially folded about groove **15a**.

Fig. 1C and 1D show lampshade **100** in folding stages until **Side A** and **Side B** of frame part **12a** and **12b** face and attaches to each other while holding on wire **18** and lamp socket **17**.

Fig. 1E and 1F show lampshade **100** in subsequent folding stages where strips **9a** and **9b** are folded vertically to each **Side A** and **Side B**, respectively, and flexible sheet part **10a** and **10b** are curved around lamp socket **17** so that projections **13** on strips **9a** and **9b** face recesses **14** on frame part **12a** and **12b** for connection.

Fig. 1G and 1H (the latter is a partially cut out view) show lampshade **100** in a final construction stage where the structure of lampshade **100** is fixed by interlocking projections **13** and recesses **14** in strips **9a** and **9b** and frame part **12a** and **12b**.

Optionally, the construction can start equivalently with **Side B**. Optionally or alternatively, the construction may progress alternating between **Side A** and **Side B**.

Sample embodiment 2

In an alternative embodiment to lampshade **100** the connected flexible sheet parts **10a** and **10b** are replaced by separate parts that are subsequently connected to the frame part as described with respect to **Figs. 2A to 2L** below.

Fig. 2A shows an open position of a thin walled frame part **210** of a 3-part lampshade comprising the frame part and two flexible sheet parts **220** (the latter illustrated in **Fig. 2B** and discussed below). Frame part **210** is divided by folding groove **24** into two complementary parts **21a** and **21b** having relief and bended structures that provide stiffness to frame part **210**. The structures comprise supports **22a** and **22b**, projections **23b** and recesses **23a**, which fit into each other, respectively, and relief structures **25a** and **25b**, which form a hollow for an electric wire (or wires) to fit in the structures when frame part **210** is mounted on the lamp as described below.

Fig. 2B shows an open position of the two flexible sheet parts **220** of the 3-part lampshade. Parts **220** comprise sheets **26a** and **26b**, with two folding

grooves **29a** and **29b** on each sheet, outlining two strips **27a** and **27b** having holes **28a** and **28b** on each part, respectively.

The 3-part lampshade **200** (see, for example, **Fig. 2I**) is constructed by connecting parts **220** on part **210**. The connection is carried out by pressing holes **28a** and **28b**, on each side of parts **220**, on projections **23b** on each side of section **21b** of part **210**, and curving parts **220** about part **210**, consequently folding section **21a** of part **210** along folding groove **24**. Next, lampshade **200** is mounted on a lamp electrical wire (or wires) above the lamp socket so that the wire is disposed between relief structures **25a** and **25b**, and lampshade **200** is fastened by interlocking projections **23b** into recesses **23a** (via holes **28a** and **28b**). Alternatively, parts **210** and **220** are folded and fastened to form the lampshade, and part **210**, being resilient, is spread about structures **25a** and **25b** to insert the lamp socket and electrical wire, and optionally the bulb as well.

A method of constructing lampshade **200** is illustrated in sequential stages in **Figs. 2C-2H**.

Fig. 2C shows part **210** folded partially along folding groove **24** and **Fig. 2D** shows how parts **220** are disposed for connecting on frame part **210**. **Figs. 2E** and **2F** show how parts **220** are connected, one after the other, on projections **23B** of part **210** through holes **28a** and **28b** of part **220**.

Fig. 2G shows how sheet-like parts **220** are curved for connection on frame part **210**, and **Fig. 2H** shows how part **210** is disposed on the lamp wire inside a hollow formed by structures **25a** and **25b** with one of parts **220** connected on both ends thereof on part **210**.

Another method of mounting lampshade **200** on the lamp wire is described below with reference to **Figs. 2I-2L**. In this method, lampshade **200** is constructed as described above and illustrated in **Figs. 2C** to **2H**, however, without disposing it on the lamp wire and without yet attaching sections **21a** and **21b** of frame part **210** by projections **23b** and recesses **23a**, as shown in **Fig. 2I**.

Fig. 2J shows how lampshade **200** is disposed about the lamp, and **Fig. 2K** how the lamp (including the bulb) is inserted in lampshade **200**, taking into

account the resilience of frame part **210** so that frame part **210** can bend to let the bulb and socket thereof to slide in.

Fig. 2L shows the final disposition of lampshade **200** on the lamp, constructed according to either method as described above. It should be noted that variations of constructing lampshade **200** are possible as one skilled in the art can appreciate, noting the configuration of parts **210** and **220**.

It should be noted that frame part **210** does not have relief structures to form a hollow for the lamp socket as frame part **12a** and **12b** of part **100** do. This variant embodiment, while not lacking in functioning and ease of assembling as a lampshade variant embodiment described with respect to **Figs. 1A** to **1H**, tends to be more compact and to require less space in the open position of the parts thereof, and tends to be easier and/or cheaper to manufacture.

Sample embodiment 3

A variation of the embodiment described with respect to **Figs. 2A** to **2L** is described below, the main difference being that flexible sheets **220** of **Figs. 2B** to **2L** are shaped like a trapezoid to form a truncated cone. For brevity and clarity the construction is described briefly with respect to the corresponding figures.

Fig. 3A shows a partially folded position of a frame part **310** of a 3-part lampshade **300**, similar to that respective to frame part **210** of **Fig. 2A**.

Figs. 3B to **3D** show sequential stages of constructing lampshade **300**, comprising frame **310** and flexible sheets **320** parts similar to those of **Figs. 2A** and **2B**.

Sample embodiment 4

While the preceding descriptions related to mounting a lampshade on a hanging lamp (e.g. from a ceiling), the lampshade such as **100**, **200** or **300** may be mounted on a standing lamp, the main differences being: (a) the lampshade is flipped upside down (relative to mounting on a hanging lamp) to engage the lamp stand pole rather than the lamp wire, and (b) optionally the relief structures (e.g. structures **25a** and **25b** of **Fig. 2A**) of the frame are wider and/or the hollows thereof are deeper to adapt to the standing lamp pole, though not necessarily fitting the whole width or diameter since the frame is resilient as discussed

above. Since the construction of the lampshade is essentially the same as for a hanging lamp, the construction of the lampshade on a standing lamp is exemplified briefly with respect to Figs. 4A to 4C below.

Figs. 4A to 4C show a 3-part lampshade 400, similar or identical to lampshade 200, comprising a frame 410 similar or identical to 210 and flexible sheets 420 similar or identical to 220. Fig. 4B shows a standing lamp 430 comprising a base and a pole and lampshade 400 (upside down relative, for example, to lampshade 200) which is mounted on the lamp pole similarly to the way lampshade 200 is mounted on the hanging lamp wire.

10 Sample embodiment 5

While in the embodiments illustrated in the preceding discussions the flexible sheets (e.g. 210 of Fig. 2B) comprised a pair of sheets, some embodiments of the invention may comprise only one sheet (e.g. a lampshade for a sconce or the like) while other embodiments comprise a larger number of sheets, optionally with different shapes, to form a lampshade of a more elaborate shape.

The constructions of the lampshade with a larger number of flexible sheets are the essentially the same as in the preceding discussions, as for example, exemplified in Figs 2A to 2H. For brevity and clarity, the construction is described briefly with respect to the corresponding Figs. 5A to 5B, where the frame is the same or equivalent to the frames illustrated in the preceding descriptions (e.g. frame 210 of Fig. 2A).

Fig. 5A shows an open position of two pairs of flexible sheet parts 520a and 520b of a lampshade 500, and Figs. 5B to 5C show the sequential stages of constructing lampshade 500, comprising parts 420a, 520b and a frame 510. Each pair of parts 520a and 520b is constructed on frame 510 as or similarly to how parts 220 are constructed on frame 210.

Sample embodiment 6

The exemplary sheet parts of the preceding embodiments (e.g. part 210 of Fig. 2A or part 510 of Fig. 5A) may further be modified and varied. For example, the sheets may have an elaborate shape, optionally with shaped partial

cuts configured to fold into or out of the sheet surface to provide ornaments to the lampshade. Additionally, a plurality of sheets (e.g. two in a lampshade comprising two pairs) may be connected to the frame on one side by fasteners as described above, and to each other on the other side by partial slits (as fasteners) as discussed briefly below with respect to **Figs. 6A to 6D**.

Figs. 6A to 6D show sequential stages of constructing a lampshade **600**, comprising a pair of flexible sheet parts **620a**, a pair of flexible sheet parts **620b**, and a frame **610** similar or identical to frame **210**.

Sheet parts **620a** and **620b** have slits **61a** and **61b**, respectively, with opposite directions, respectively, that allow connecting the parts to each other by inserting one part's slit into the other one's (as used, for example, in building paper or cardboard boxes out of flat parts). The other side of parts **620a** and **620b** (not connected by the slits to each other) are connected to frame **610** by projections and recesses through holes as discussed above.

A dotted region in **Fig. 6B** indicates how parts **620a** and **620b** are connected with slits **61a** and **61b**.

It should be noted that, as an additional variation, parts **620a** and **620b** have ornamental shapes and ornamental partial and full cutouts **62**.

Sample embodiment 7

The assembled lampshades typically have a substantial vertical strength (as when mounted on a hanging lamp or standing lamp), similar to a hollow column, and optionally strengthened by the stiffened frame.

As such, the lampshade, or a variant thereof, may be used as stand for a lamp, as described briefly with respect to **Figs. 7A to 7C**, below.

Fig. 7A shows a partial stage of constructing a lamp stand, similar to constructing a lampshade, such as lampshade **200**, with a frame **710** and sheet-like parts **720** with a lamp **730** having a holder **71**. Frame **710** is attached to holder **71** in a similar manner as frame **210** is attached to a lamp wire or pole, while the wire **72** of lamp **730** exits the base through an opening in one of sheet-like parts **720** (or any other manner that may be decided).

Figs. 7B shows a variant of a lamp base **740** where lamp wire **72** exits a sheet-like part through an opening **73**.

Figs. 7C shows a variant of a lamp base **750** where lamp wire **72** exits a sheet-like part through an opening **74**, which may look somewhat more decorative than opening **73** of lamp base **740**.

General discussion

The embodiments discussed above are a few examples how a frame and flexible sheets can be used. Combinations and variations of the parts discussed and use thereof may be appreciated by one skilled in the art.

The shape of the stiffened frame can vary in different embodiments, including also different relief and bending structures. The flexible sheet parts may have ornamental prints or applications on their surfaces, either on the external or internal surfaces. Other elements may be used as well, such as optical elements applied on or in the parts to give special lighting effects, optionally in addition to the light shading.

The lampshade parts are typically, but without limiting made of one or more polymeric materials or a mixture and/or combination of polymeric and non-polymeric materials. Typically, but without limitation, the parts are fabricated from a sheet, optionally, but not limited to, from thin transparent or semi-transparent or translucent sheets or foils.

Preferably, but without limiting, the parts are manufactured by an inexpensive mass production process such as cold forming or stamping that form the outline of the parts as well as the relief structures and/or cut out and/or applications and/or other elements such as optical elements. Optionally other fabrication techniques are used, comprising, for example, molding or injection.

The frame part may be opaque since it does not necessarily have a shading or light effect role. The frame part is stiffened by relief structures or other elements formed or built on or into the frame part, but yet the frame part is resilient (e.g. semi-rigid) and/or flexible to facilitate construction of the lampshade or inserting the lamp recess or bulb or electrical wire as described

above. Optionally, the frame may be fabricated from thin metal sheet such as by cold forming or stamping.

As may be appreciated by the preceding discussions, the construction of the lampshade from the parts thereof is easy and involves just the insertions of projections to recess, or interleaving slits or connections with fasteners. 5
Optionally, the connection elements may comprises members such as hook and loop connectors, buttons and holes or other easy fast fasteners in common use or that may be manufactured. The fasteners may be located on the flexible sheet part and/or the frame, and may comprise matching pairs of fasteners such as
10 where one part of a pair is on the frame and the other on the flexible sheets, such as holes and projections as described above. The flexible sheets may connect between each other by slits, as shown above, or by any fastener. It should be noted that typically, without limiting, no tools or particular skill is required to construct the lampshade.

15 In the specification and claims, unless otherwise specified, the term 'fastener' denotes also an element of a fastener in a fastener pair.

General

The terms 'vertical', 'perpendicular', 'parallel', 'opposite', 'straight', 'planar', 'rectangular', 'square', 'circular', 'round', 'elliptical', 'oval', 'cylindrical', 'sphere' and
20 other angular and geometrical shapes and relationships and inflections thereof imply also imprecise yet functional and/or practical respective relationships.

The terms 'about', 'close', 'approximate' and inflections thereof denote, unless otherwise specified or implied in the context, a sufficient functional and/or practical respective relation or measure or amount or quantity or degree
25 according to the context in which the terms or their inflections appear.

The terms 'substantial', 'considerable', 'significant' and inflections thereof denote, unless otherwise specified or implied in the context, a measure or extent or amount or degree which is large or effective or important relative to the rest of the referenced subject matter.

30 The terms 'negligible', 'slight' and 'insignificant' and inflections thereof denote, unless otherwise specified or implied in the context, a sufficiently small

functional and/or practical respective relation or measure or amount or quantity or degree according to the context in which the terms or their inflections appear.

The term 'similar', in addition to the ordinary meaning, relates to structures or methods of procedures that a difference in the position or order or sequence of the elements thereof yields an equivalent functionality or effect.

The terms "comprises", "comprising", "includes", "including", "having" and their inflections and conjugates denote "including but not limited to".

The present invention has been described using descriptions of embodiments thereof that are provided by way of example and are not intended to limit the scope of the invention. The described embodiments comprise various features, not all of which are necessarily required in all embodiments of the invention. Some embodiments of the invention utilize only some of the features or possible combinations of the features. Alternatively and additionally, portions of the invention described/depicted as a single unit may reside in two or more separate physical entities which act in concert to perform the described/depicted function. Alternatively and additionally, portions of the invention described/depicted as two or more separate physical entities may be integrated into a single physical entity to perform the described/depicted function. Variations of embodiments of the present invention that are described and embodiments of the present invention comprising different combinations of features noted in the described embodiments can be combined in all possible combinations including, but not limited to use of features described in the context of one embodiment in the context of any other embodiment.

In the specifications and claims, unless otherwise specified, when a range of values is recited, it is merely for convenience or brevity and includes all the possible sub-ranges as well as individual numerical values within that range. Any numeric value, unless otherwise specified, includes also practical close values enabling an embodiment or a method, and integral values do not exclude fractional values. A sub-range values and practical close values should be considered as specifically disclosed valued.

CLAIMS

1. A foldable lampshade, comprising:

(a) a stiffened frame made of at least one thin-walled part defining a space therein in which a lamp bulb can be disposed and defining a hollow for mounting
5 on a lamp component; and

(b) at least one flexible sheet-like part mounted on the frame for shading the lamp bulb.

2. A lampshade according to claim 1, wherein the frame is stiffened by structures comprised in the thin-walled part.

10 **3.** A lampshade according to any one of the preceding claims, wherein the structures comprise at least one of relief structures or bends.

4. A lampshade according to any one of the preceding claims, wherein the frame is resilient.

15 **5.** A lampshade according to any one of the preceding claims, wherein the frame comprises two sections foldable along a folding groove therebetween.

6. A lampshade according to any one of the preceding claims, wherein the frame sections comprise relief structures that that fit, at least partly, a hanging lamp electrical wire or a standing lamp pole.

20 **7.** A lampshade according to any one of the preceding claims, wherein the frame sections complement each other to form at least one hollow to fit on at least one component of the lamp.

8. A lampshade according to any one of the preceding claims, wherein the frame comprises at least one fastener configured to attach at least the sections thereof.

25 **9.** A lampshade according to any one of the preceding claims, wherein the at least one fastener is an integral part of the frame.

10. A lampshade according to any one of the preceding claims, wherein at least one fastener is attached to the frame.

11. A lampshade according to any one of the preceding claims, wherein the at least one flexible sheet-like part comprises a plurality of sheet-like parts.

12. A lampshade according to any one of the preceding claims, wherein the at least one flexible sheet-like part connects by at least one edge thereof to the frame as an integral part.
13. A lampshade according to any one of the preceding claims, wherein the at least one flexible sheet-like part connects by at least one edge region thereof to the frame by at least one fastener.
14. A lampshade according to any one of the preceding claims, wherein at least two parts of the flexible sheet-like parts connect to each other by at least one fastener.
15. A lampshade according to any one of the preceding claims, wherein the lampshade is assembled by folding parts thereof.
16. A lampshade according to any one of the preceding claims, wherein the lampshade is disassembled by unfolding parts thereof.
17. A lampshade according to any one of the preceding claims, wherein at least one of the frame or flexible sheets comprises a polymeric material.
18. A lampshade according to any one of the preceding claims, wherein at least one of the frame or flexible sheets are adaptable for fabrication from a sheet or foil.
19. A lampshade according to any one of the preceding claims, wherein the lampshade parts are configured to open separately into a substantially flat form.
20. A lampshade according to any one of the preceding claims, wherein the lampshade parts are configured for construction without tools.
21. A lampshade according to any one of the preceding claims, wherein the lampshade is configured for mounting on a lamp wire or pole while maintaining the lamp socket connected to an electrical wire.
22. A lampshade according to any one of the preceding claims, wherein the lampshade is configured for mounting on a lamp wire or pole while maintaining the light bulb within the lamp socket.
23. A lampshade according to any one of the preceding claims, wherein the lampshade is configured for construction as a lamp stand in which a lamp socket is mounted on the frame.

24. A foldable lamp stand, comprising:

(a) a stiffened frame made of at least one thin-walled part defining a space therein which a lamp bulb can be disposed and defining a hollow for mounting on a lamp component; and

5 (b) at least one flexible sheet-like part mounted on the frame for shading the lamp bulb.

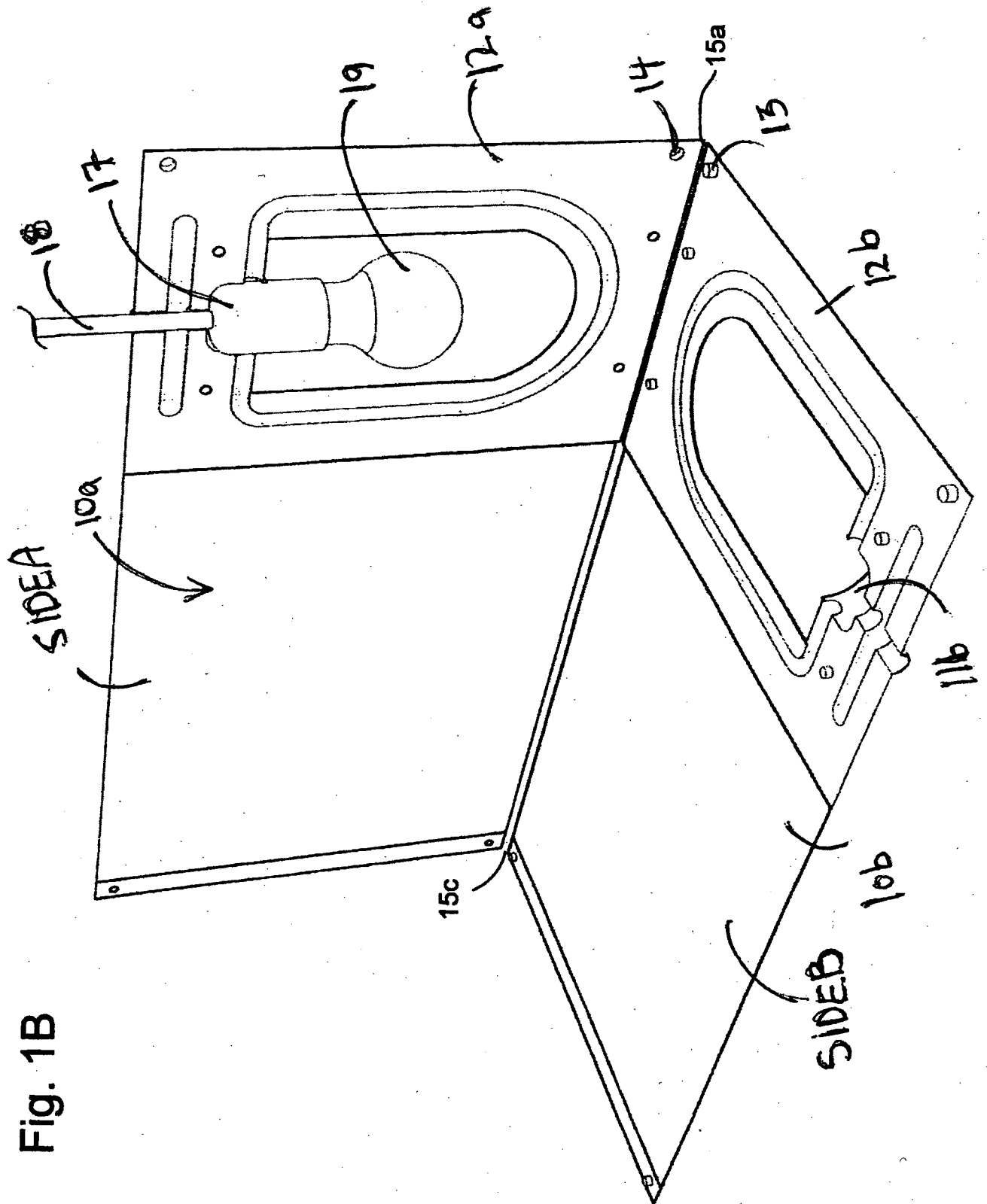
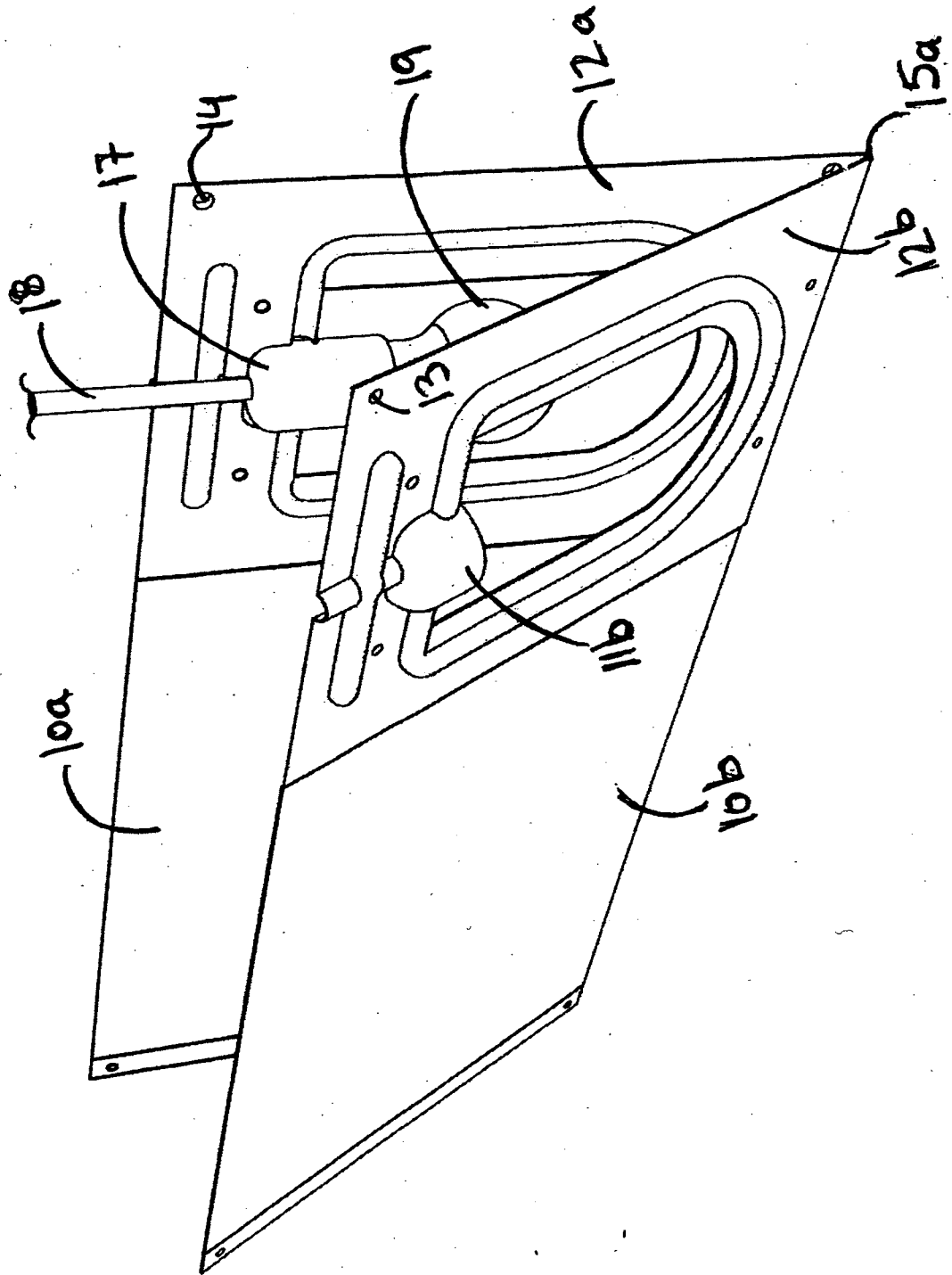

Fig. 1B

Fig. 1C



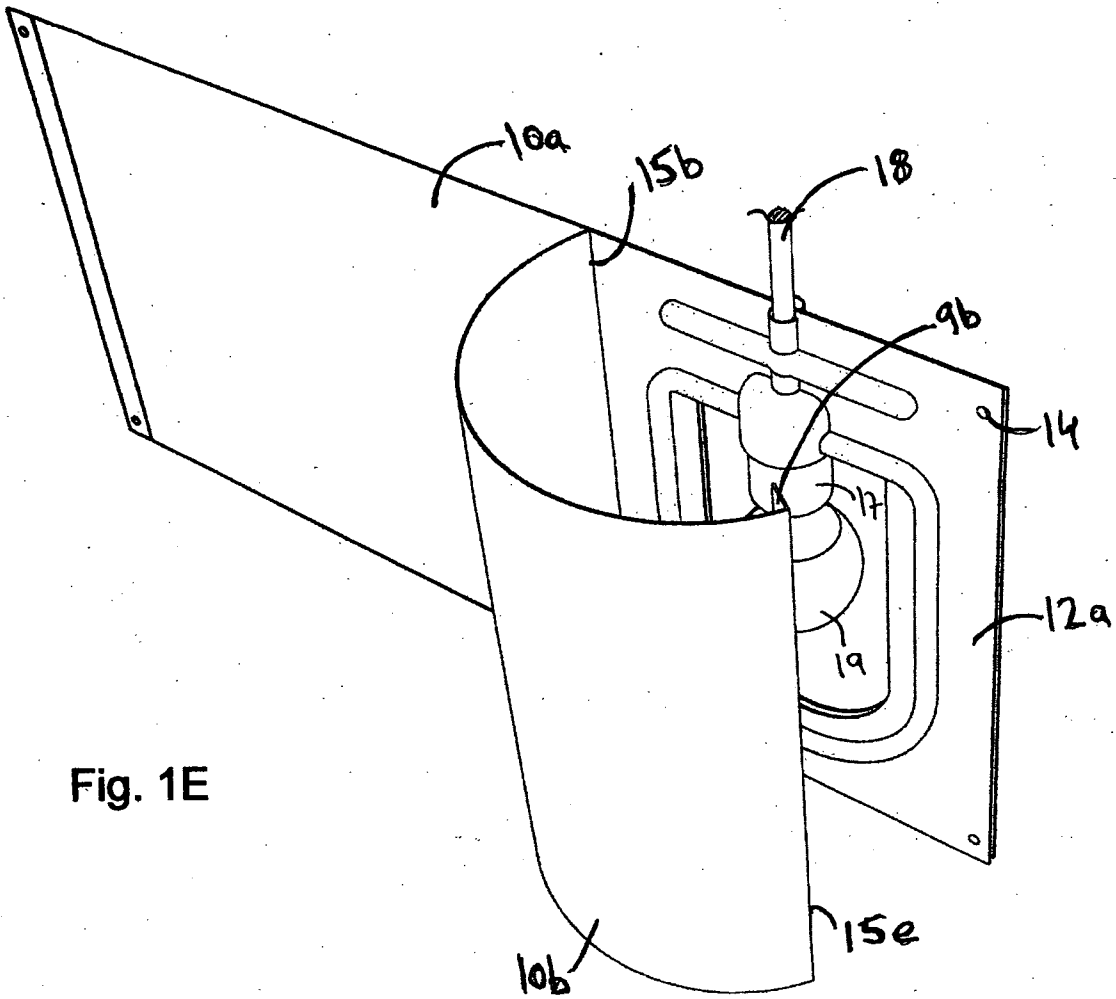

Fig. 1E

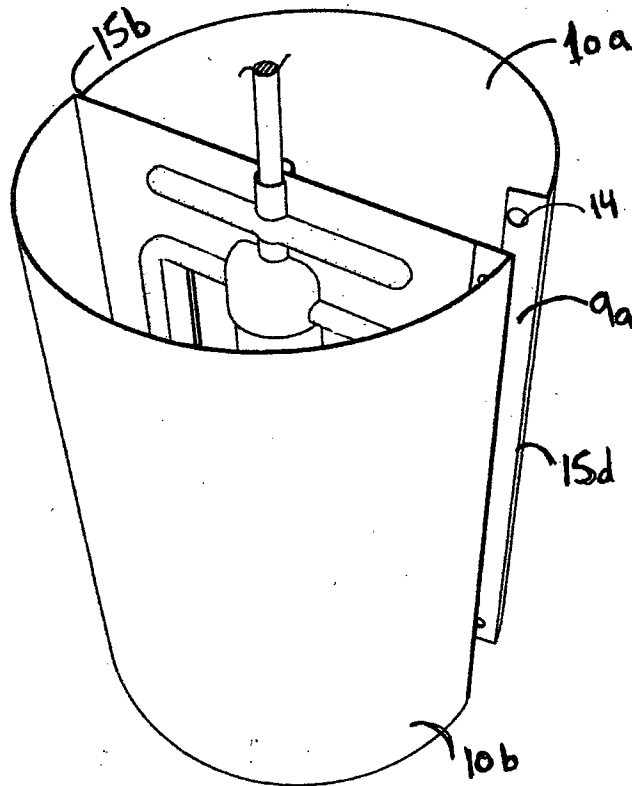

Fig. 1F

Fig. 1G

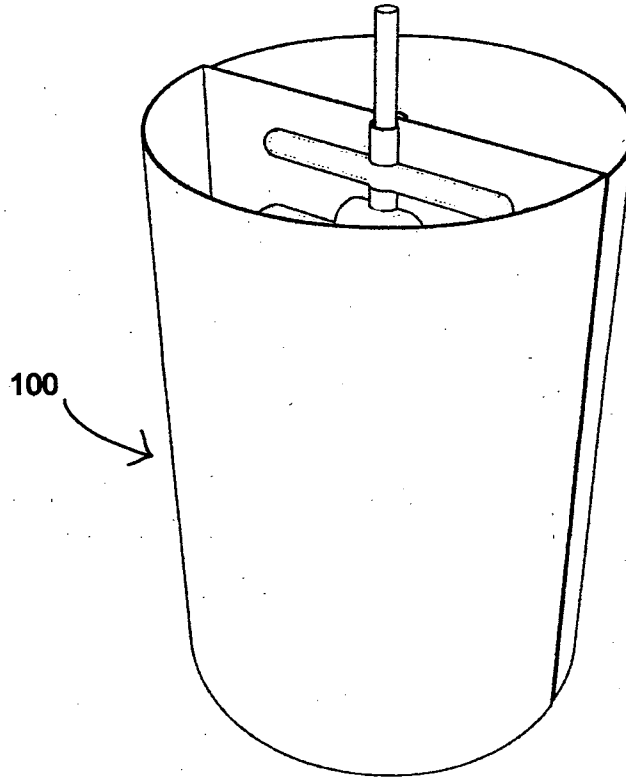
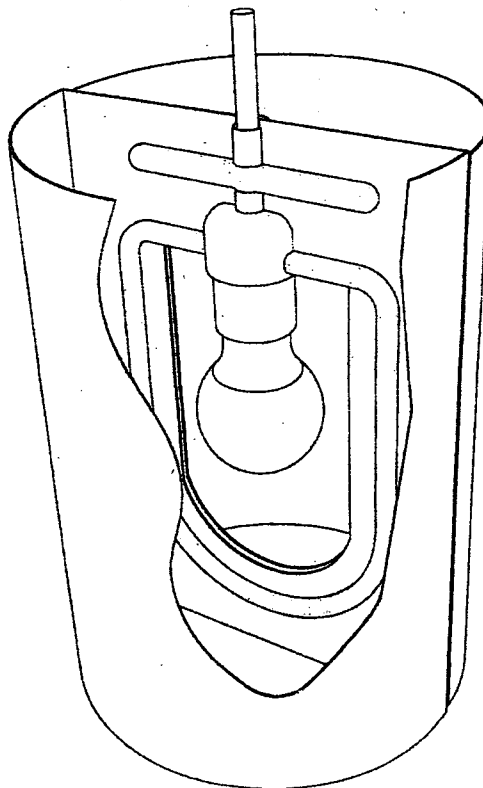

Fig. 1H



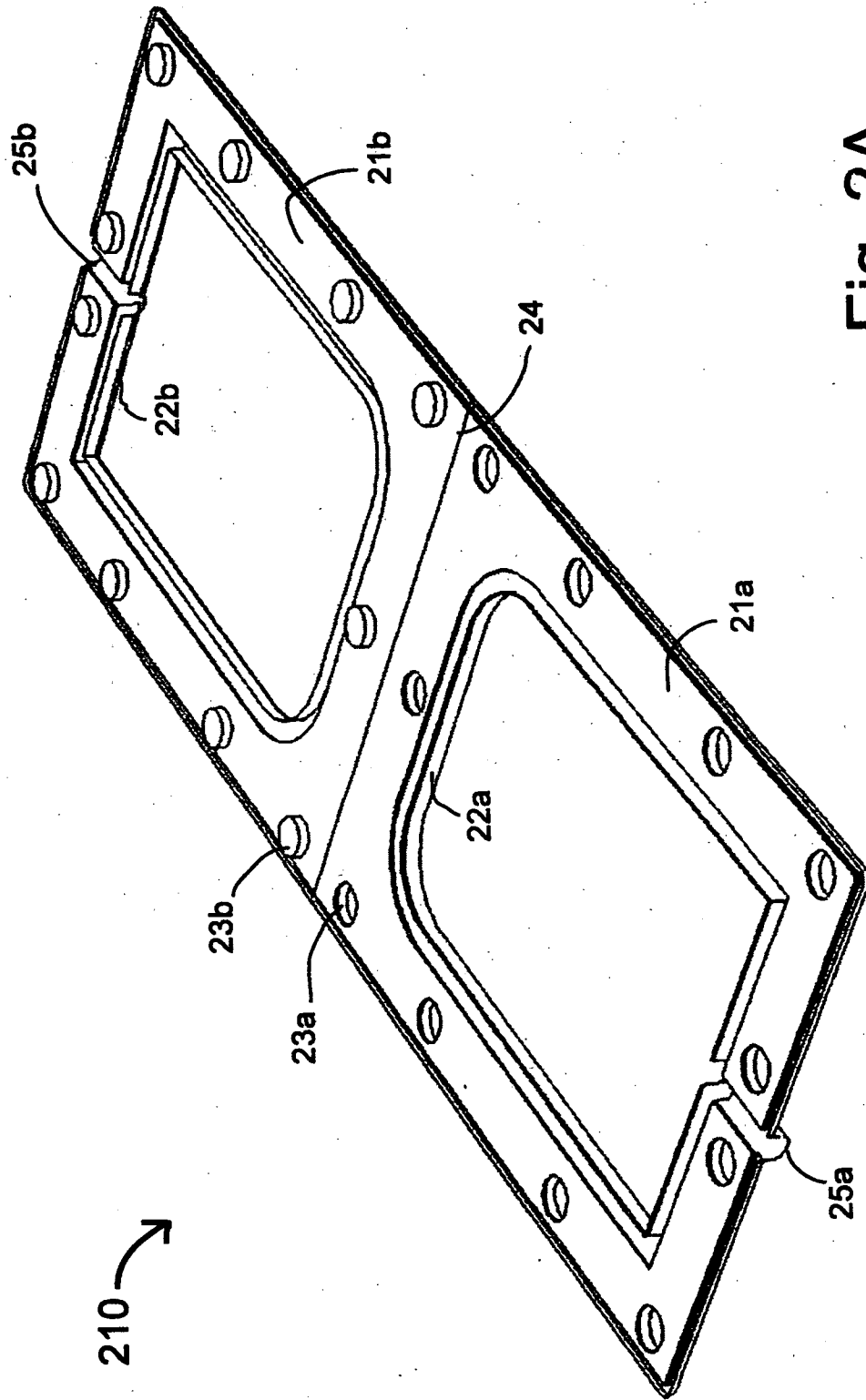

Fig. 2A

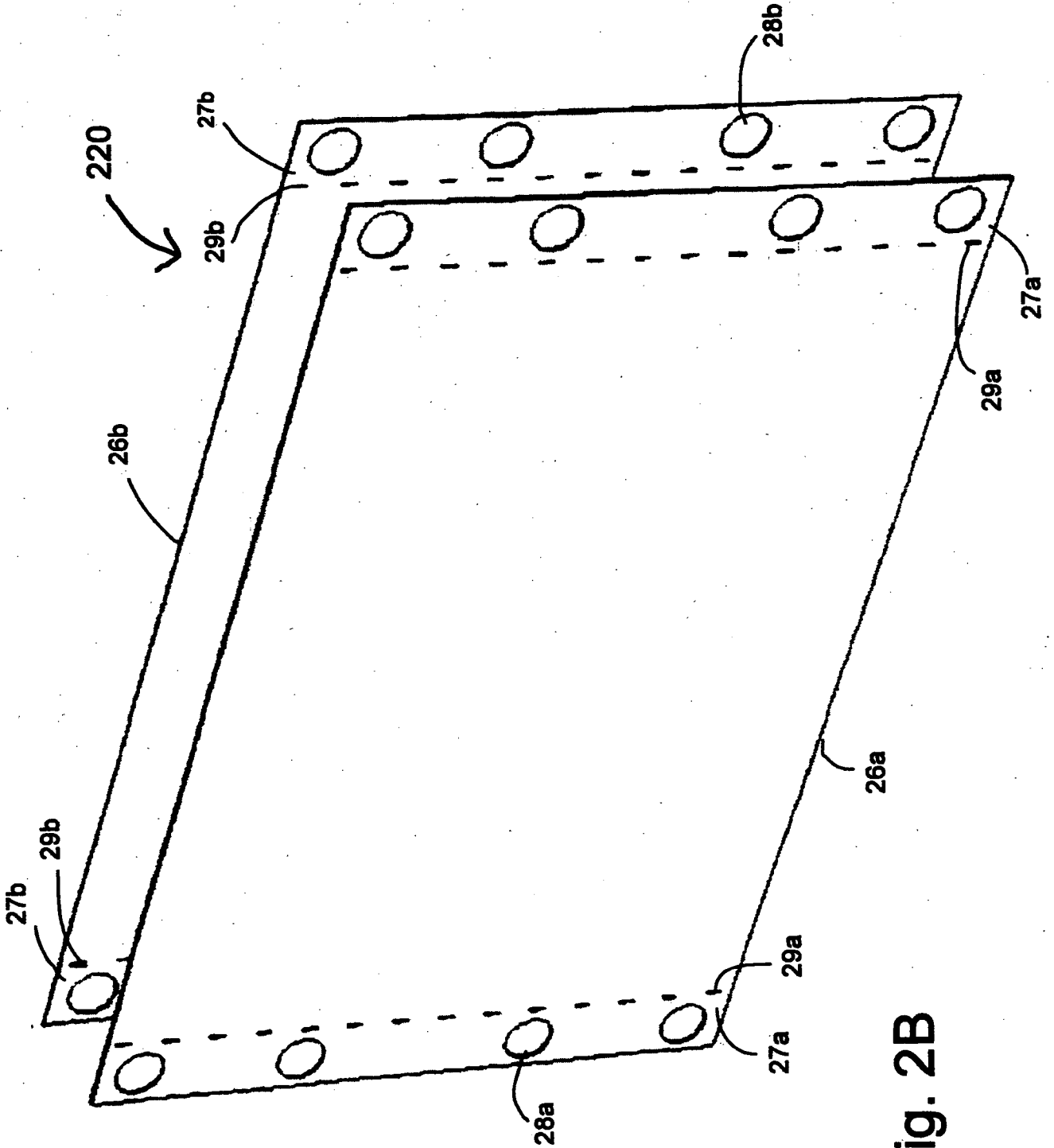

Fig. 2B

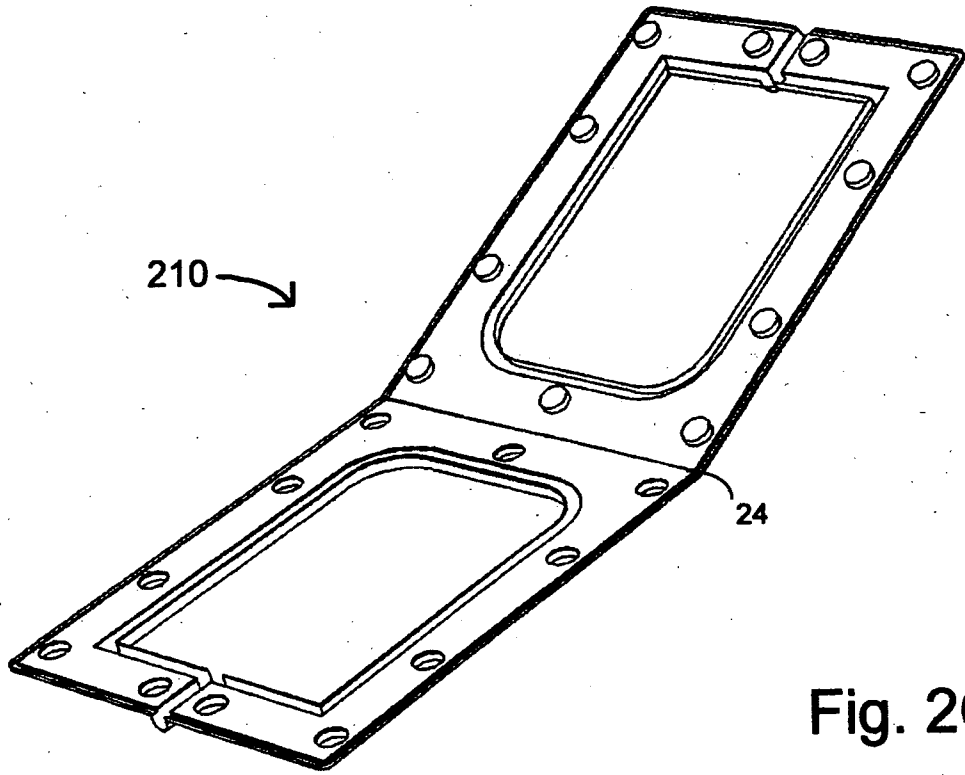

Fig. 2C

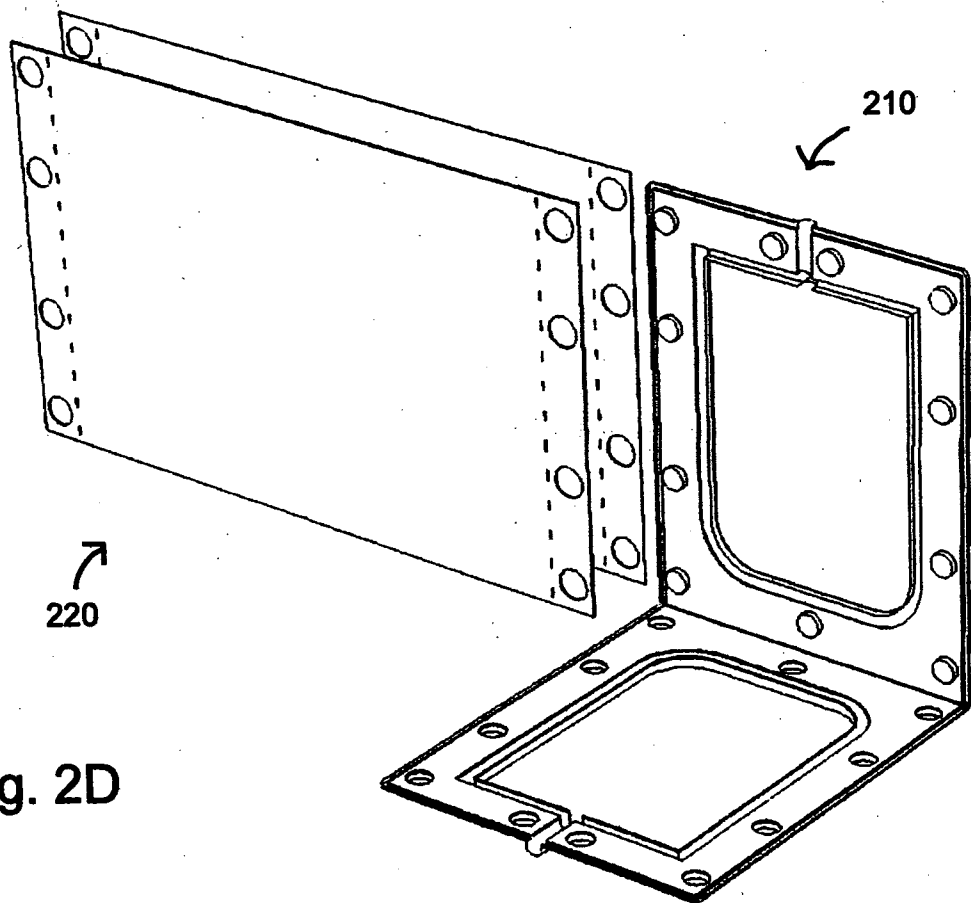

Fig. 2D

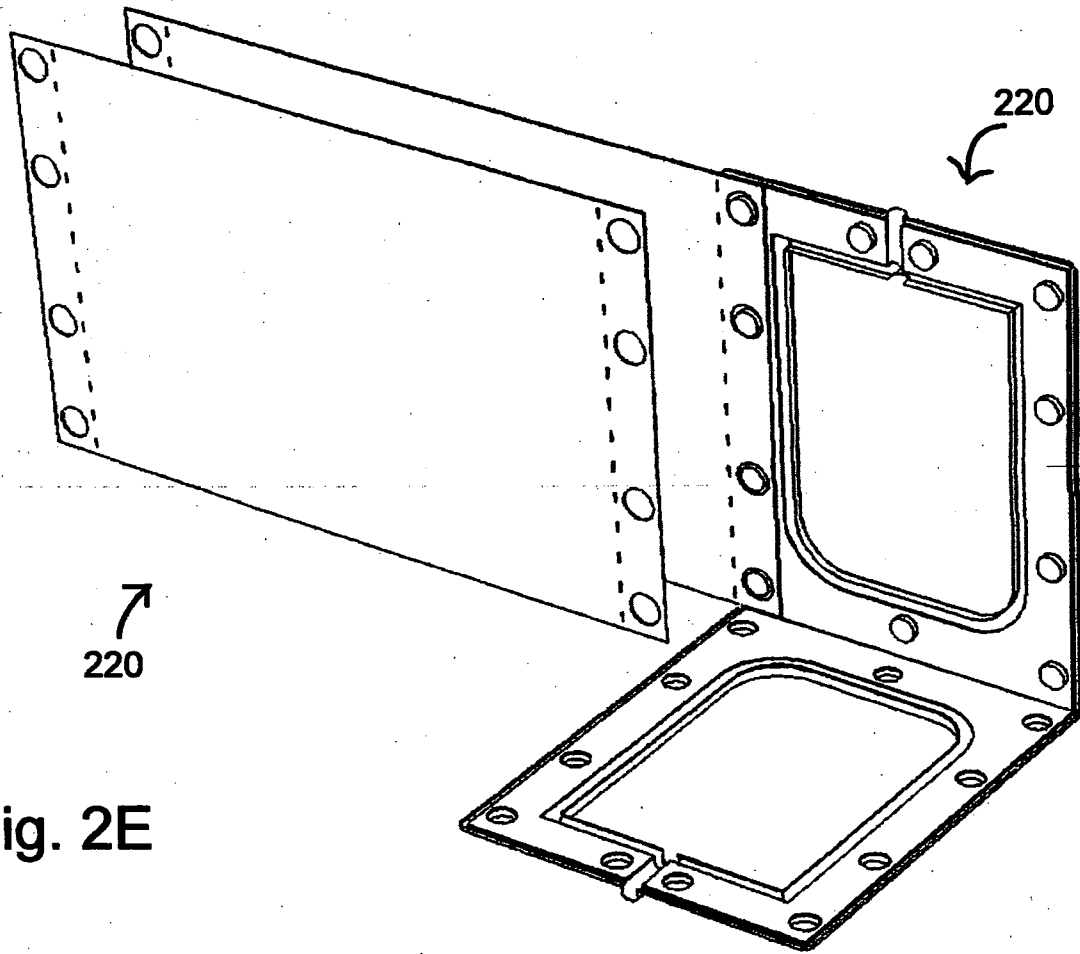

Fig. 2E

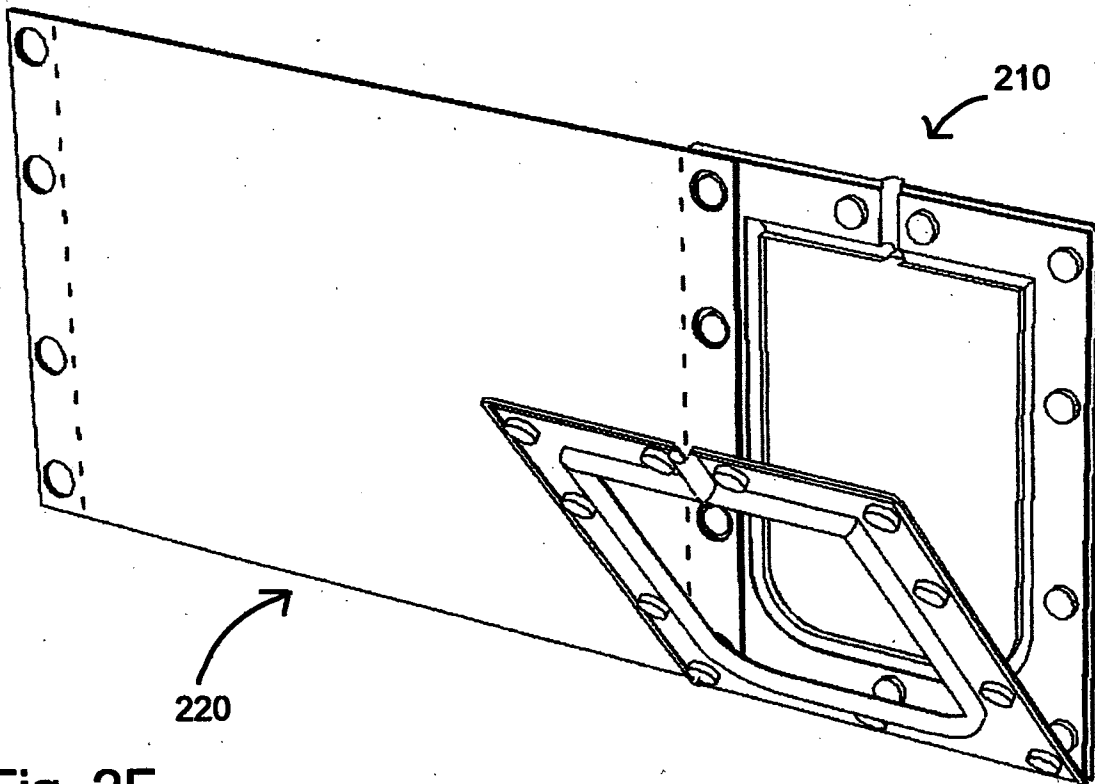
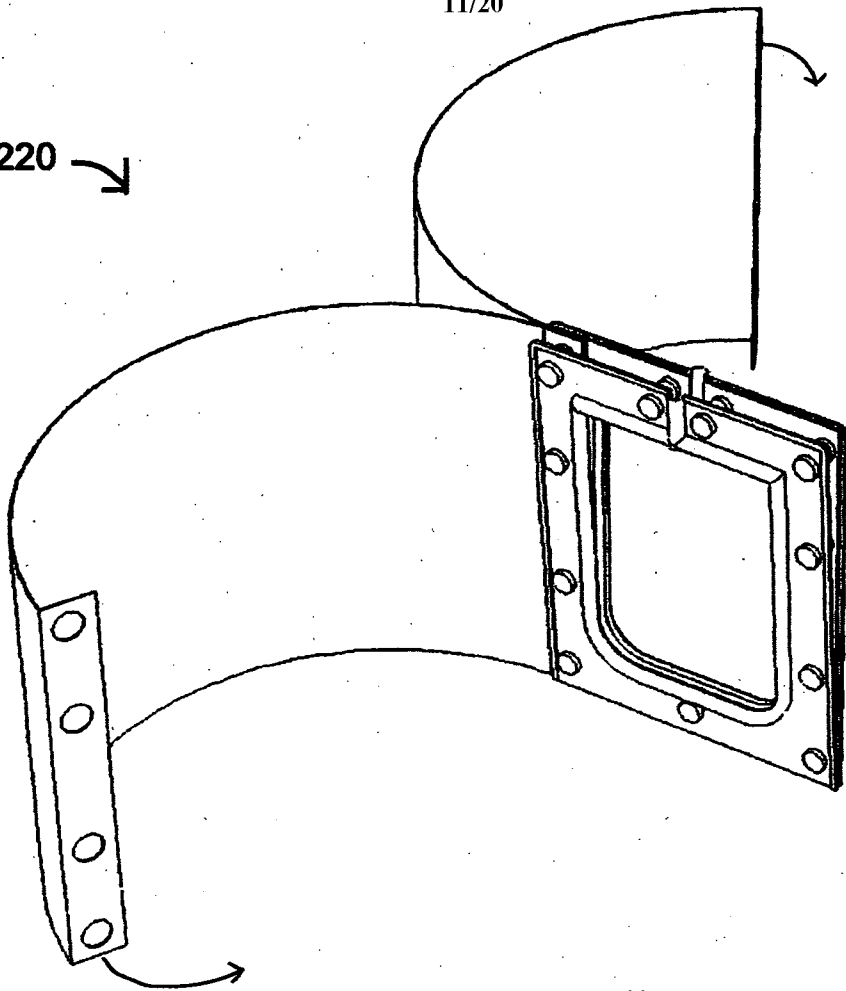

Fig. 2F

11/20

220



210

Fig. 2G

Fig. 2H

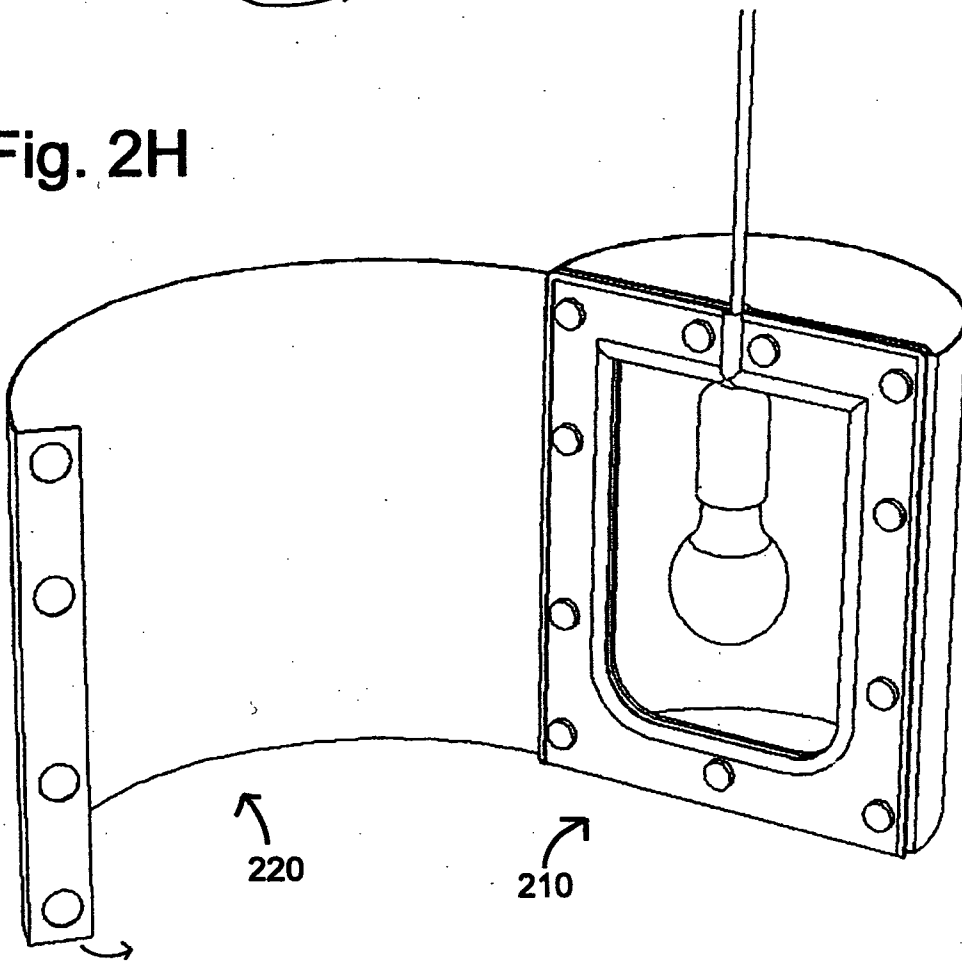

220

210

Fig. 2J

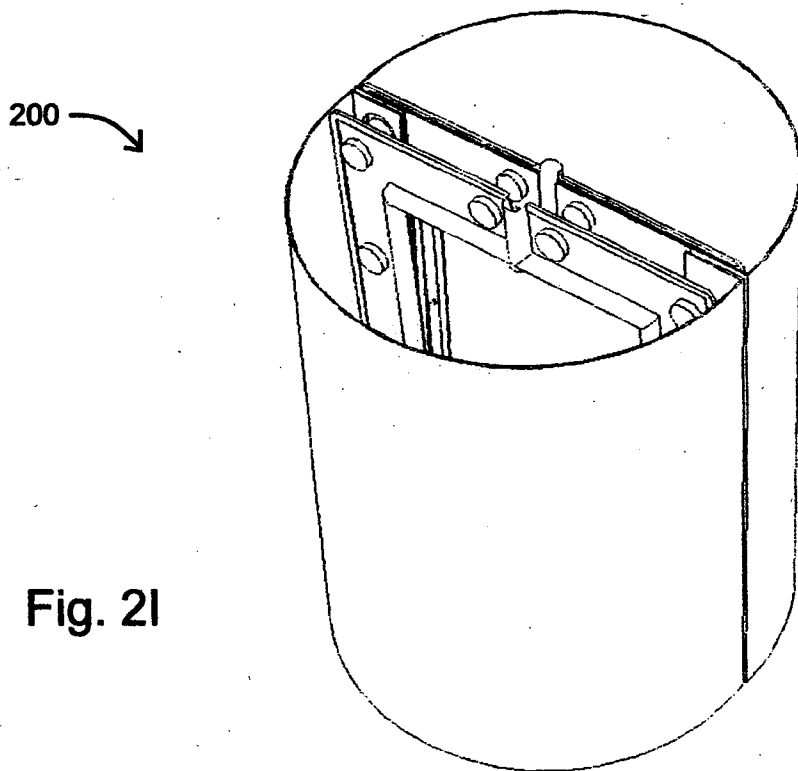
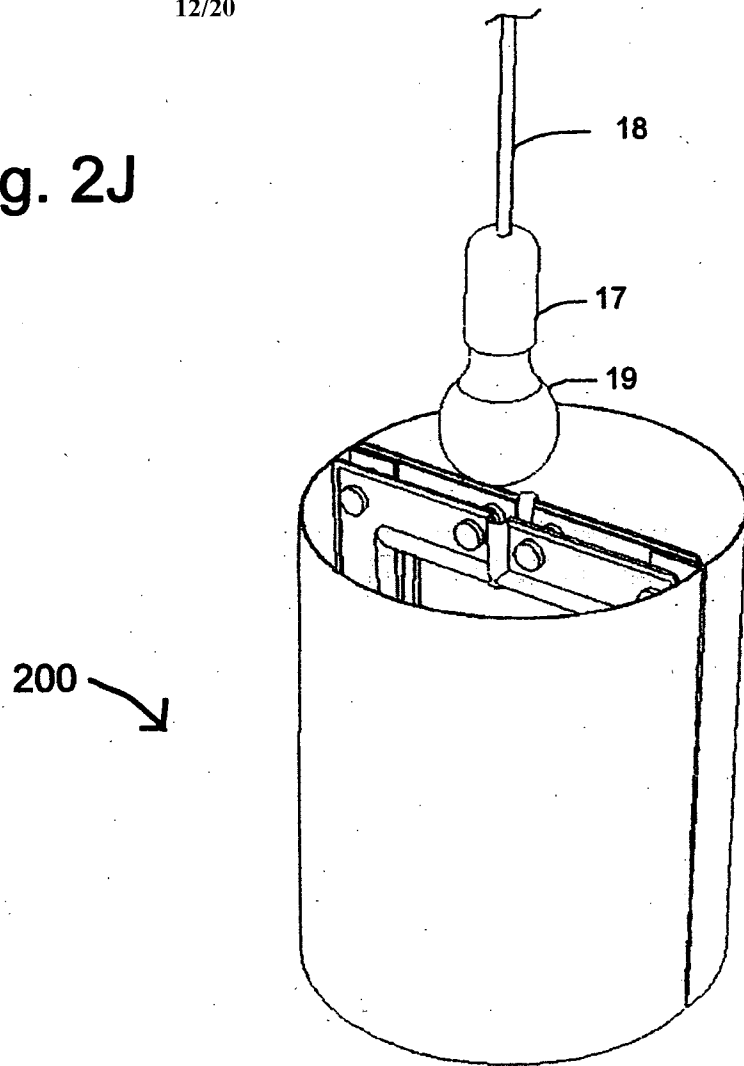

Fig. 2I

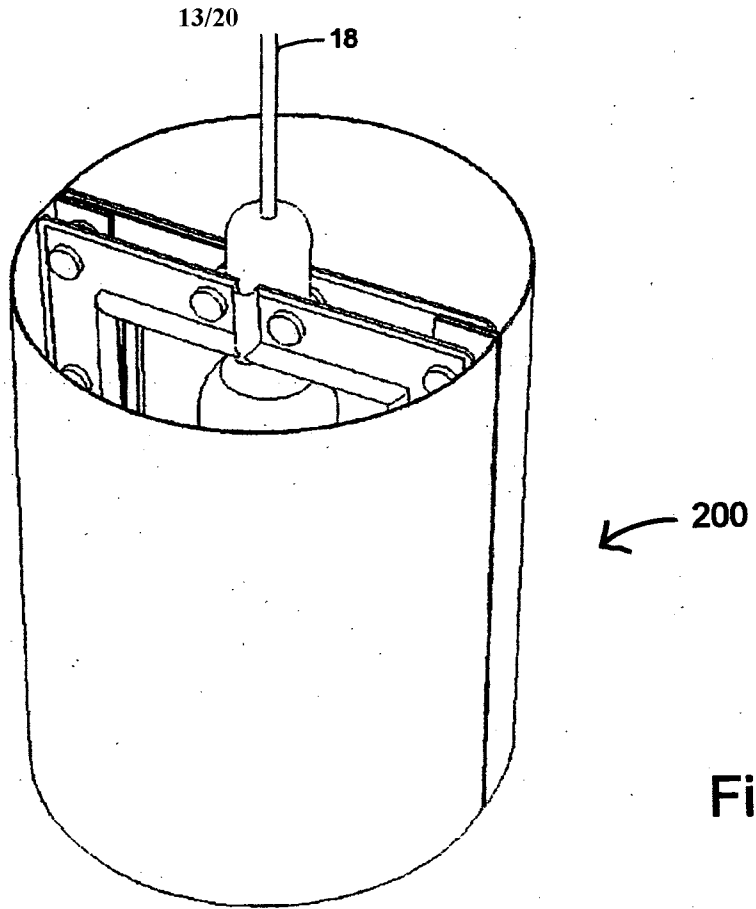

Fig. 2K

Fig. 2L

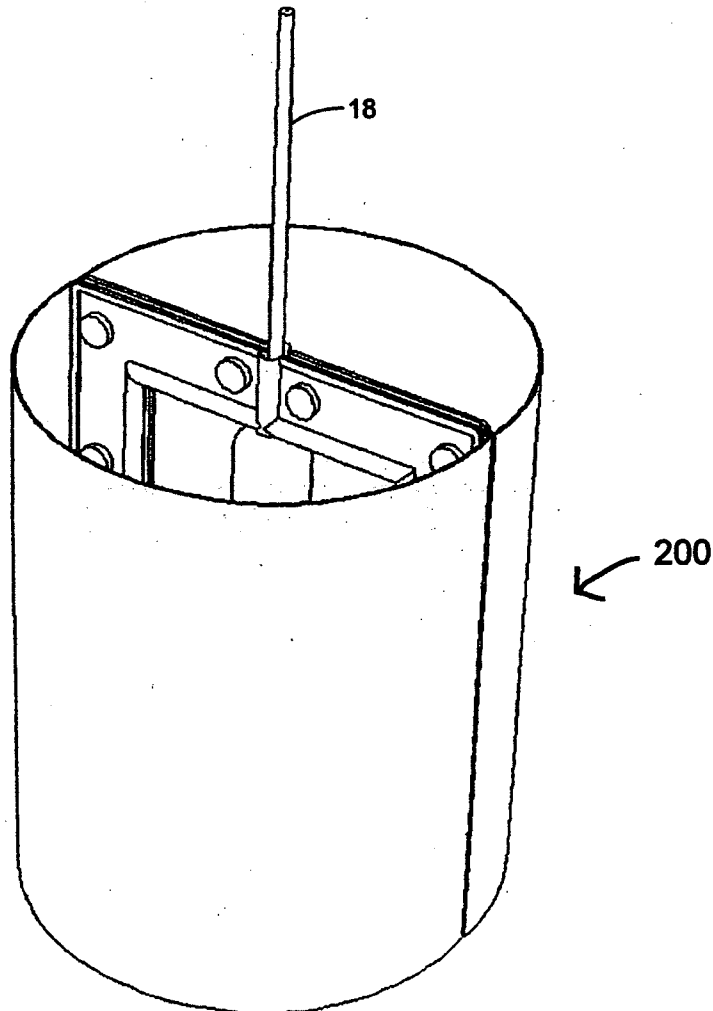

Fig. 3A

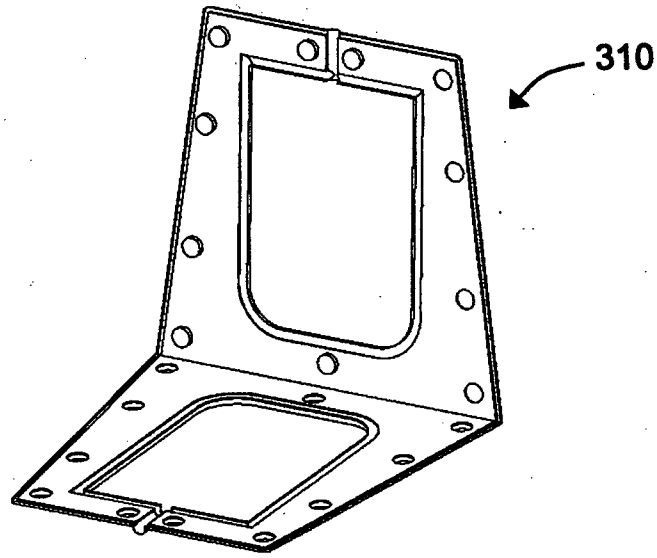

Fig. 3B

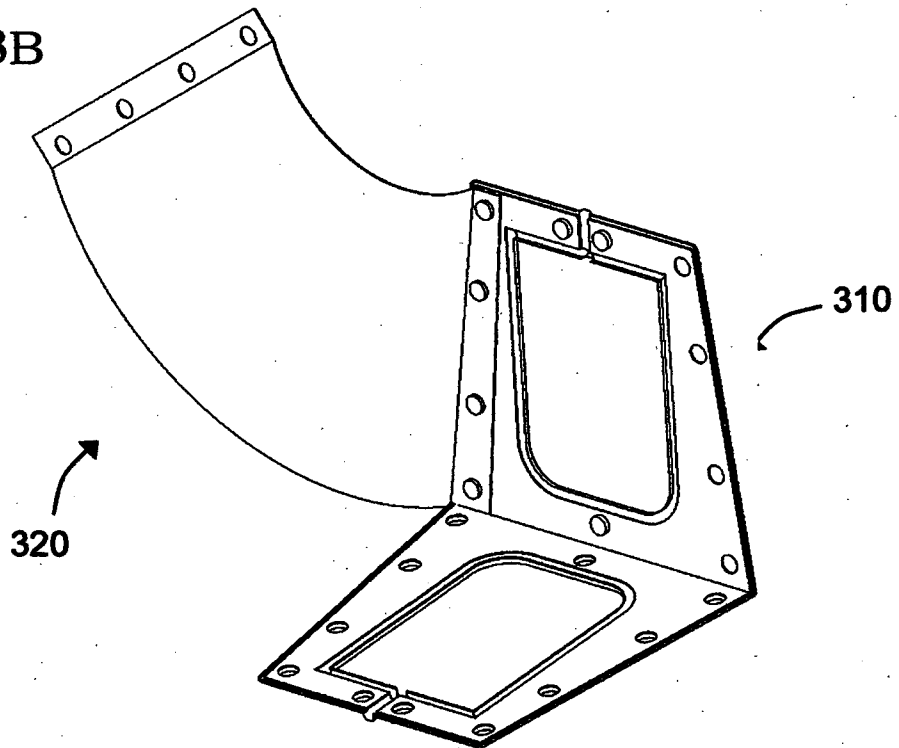

Fig. 3C

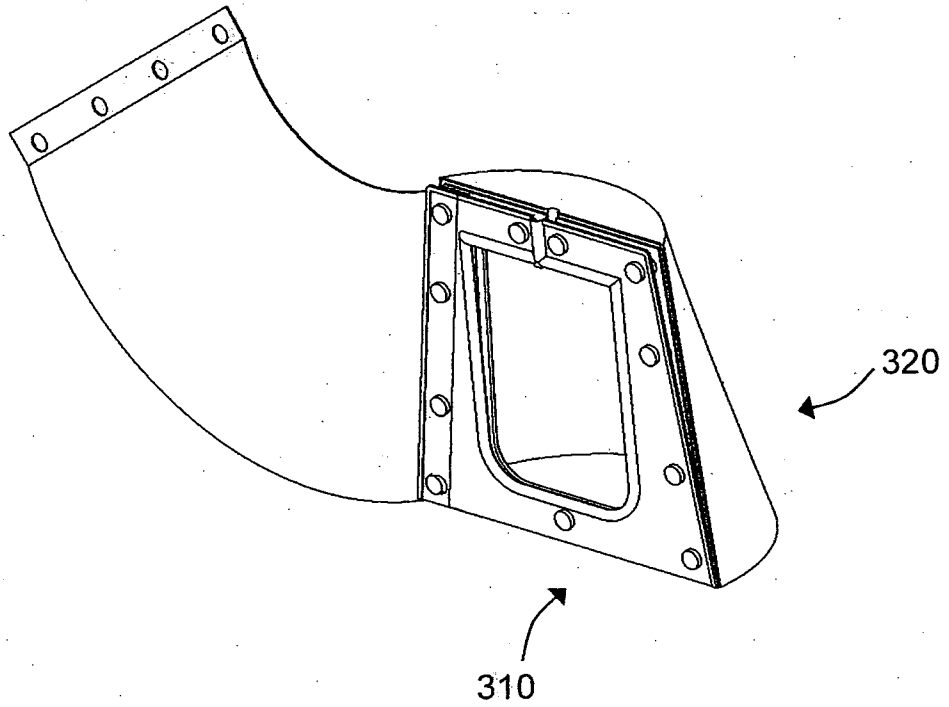

Fig. 3D

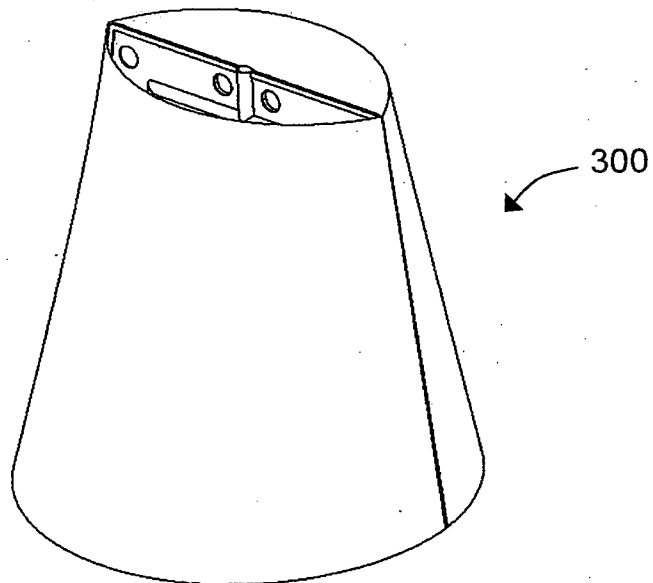

Fig. 4A

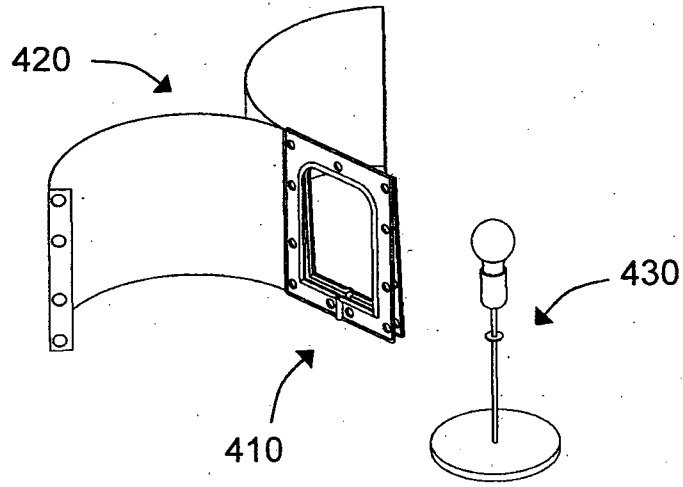

Fig. 4B

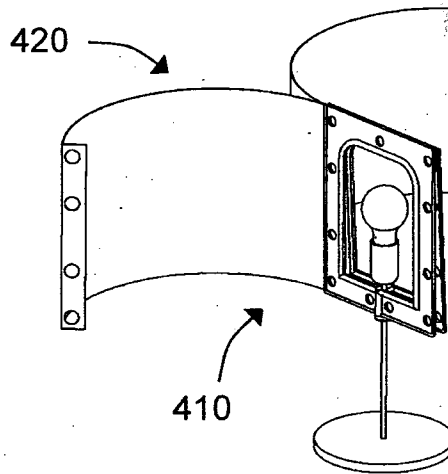

Fig. 4C

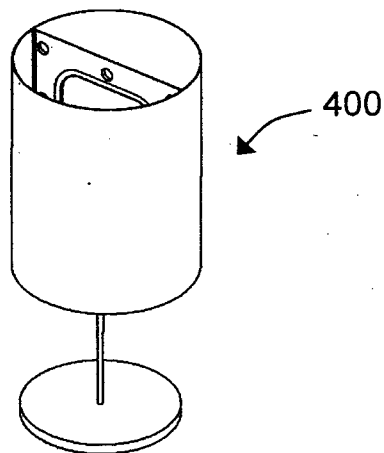

Fig. 5A

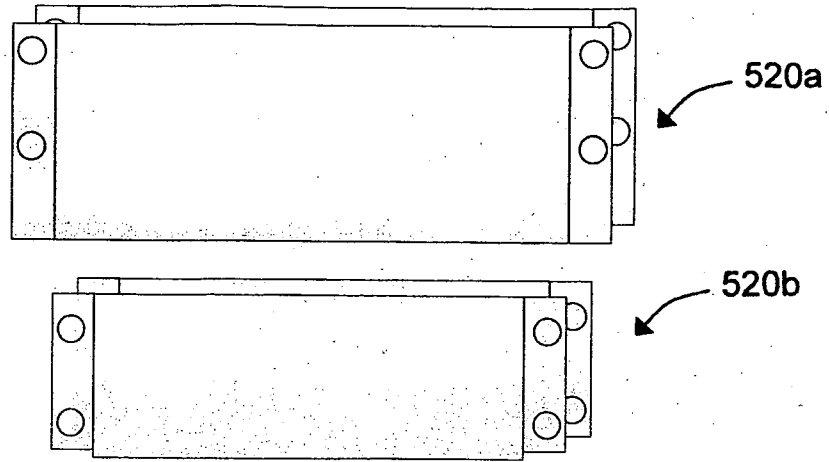

Fig. 5B

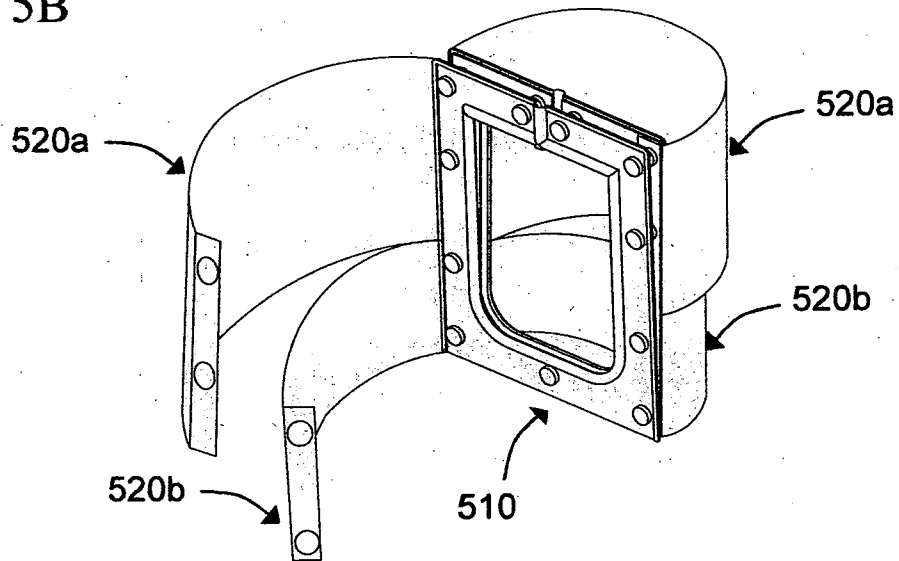

Fig. 5C

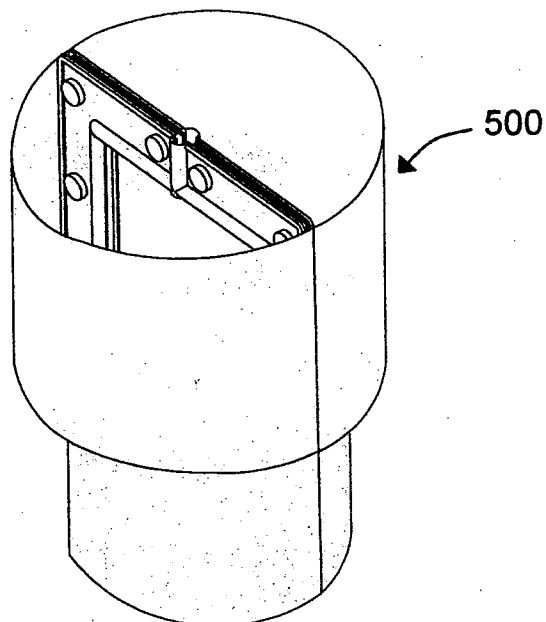

Fig. 6A

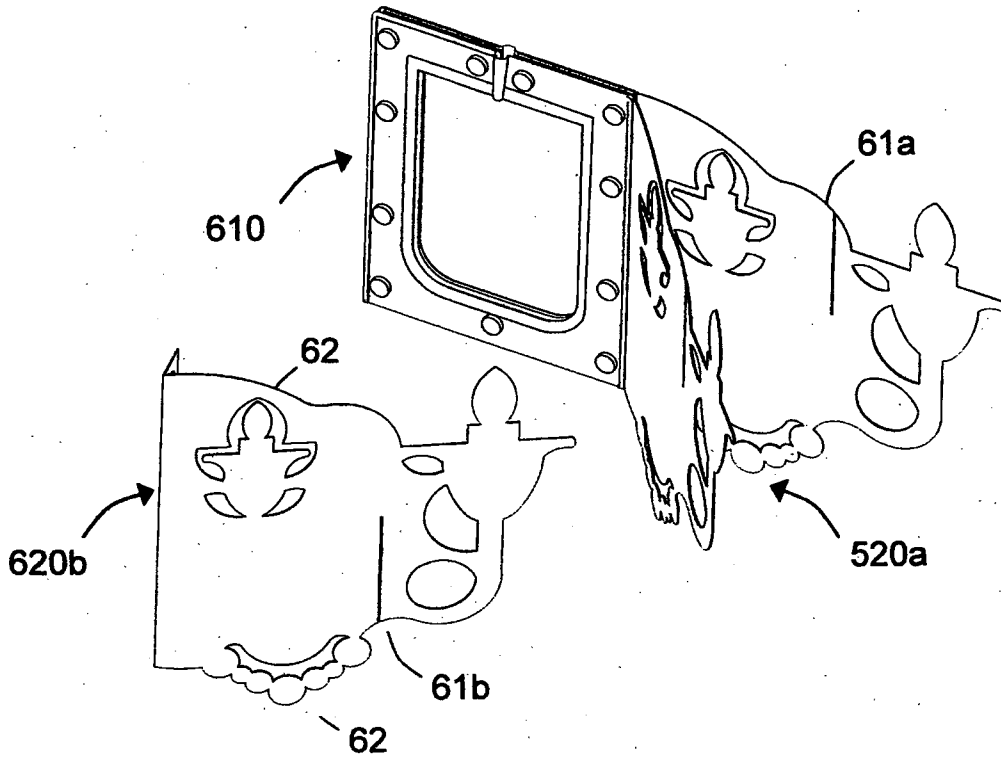

Fig. 6B

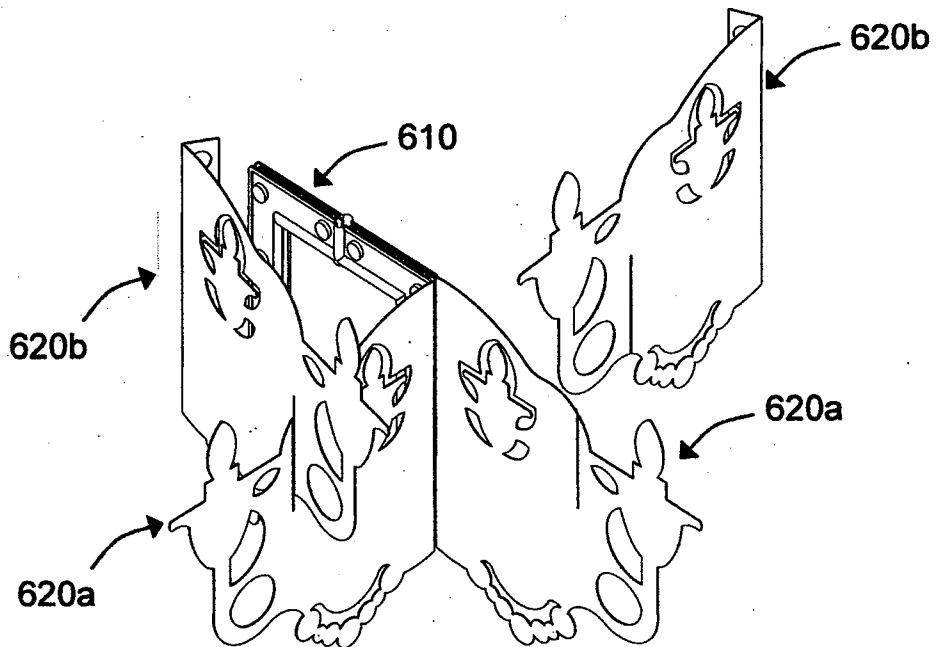

Fig. 6C

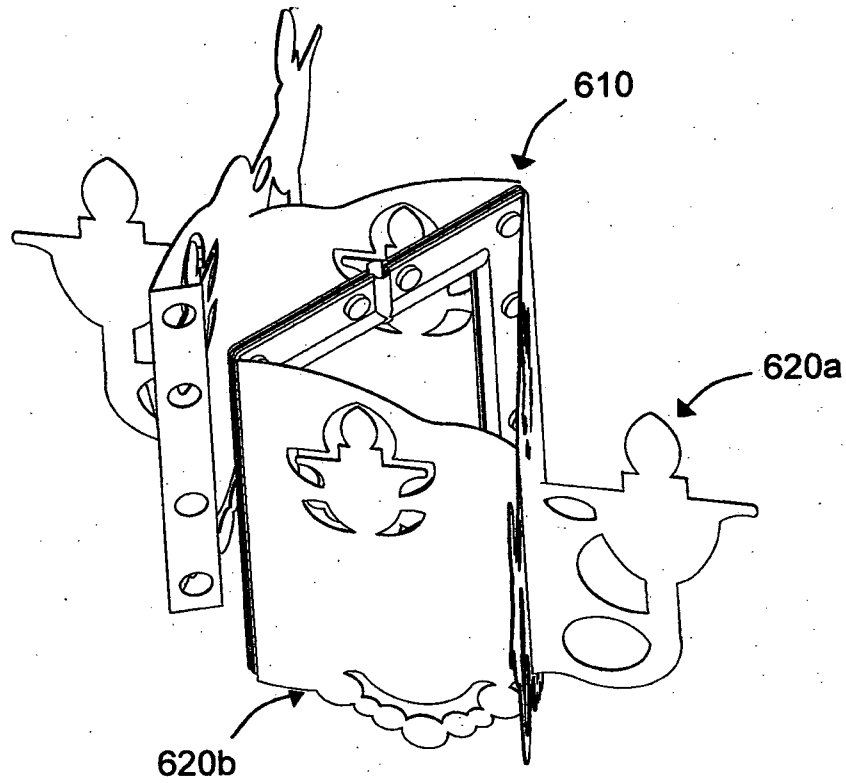

Fig. 6D

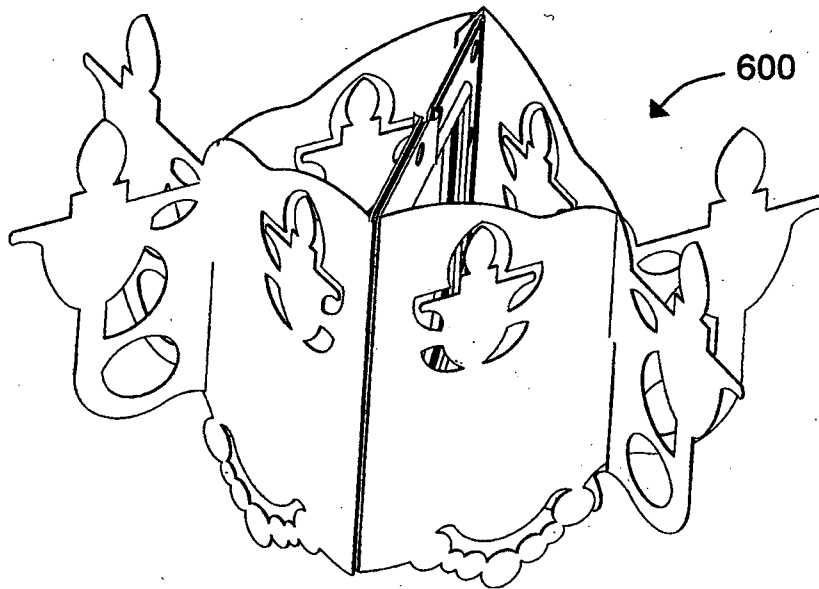

Fig. 7A

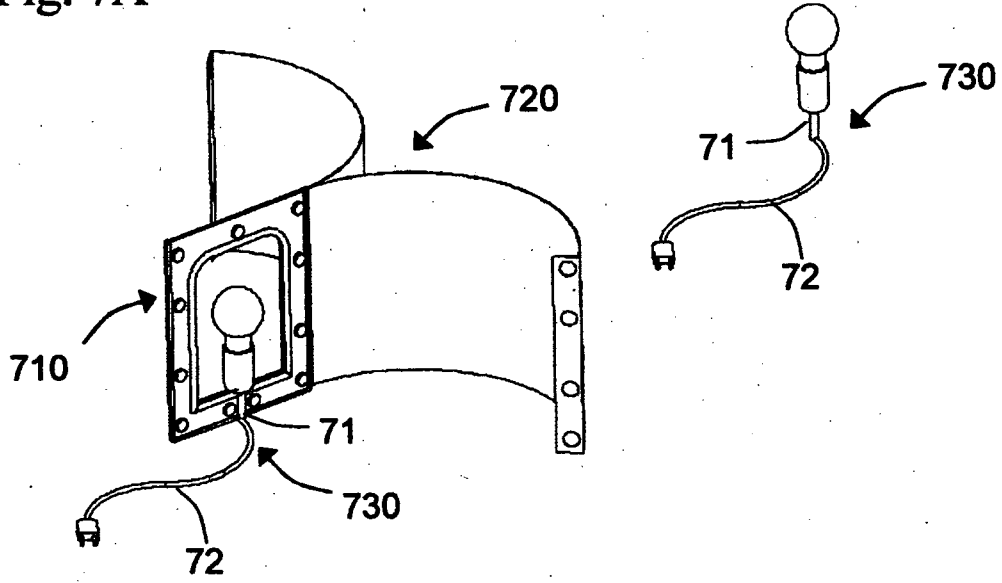

Fig. 7B

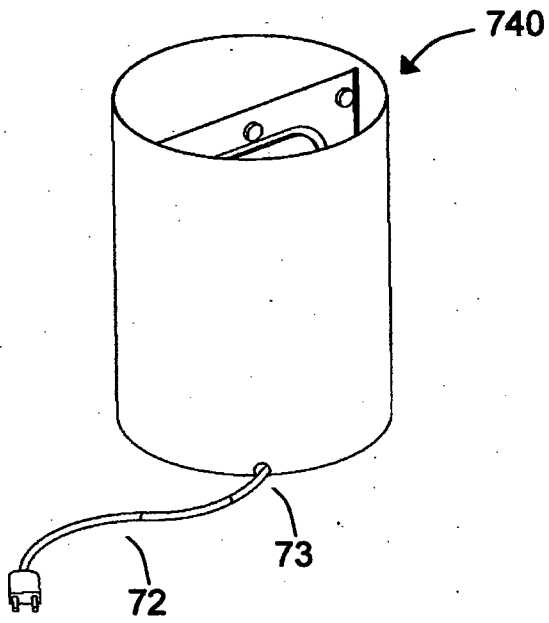

Fig. 7C

