

June 19, 1951

H. HAHN

2,557,280

COMBINATION MUFF AND SHOPPING BAG

Filed Oct. 12, 1948

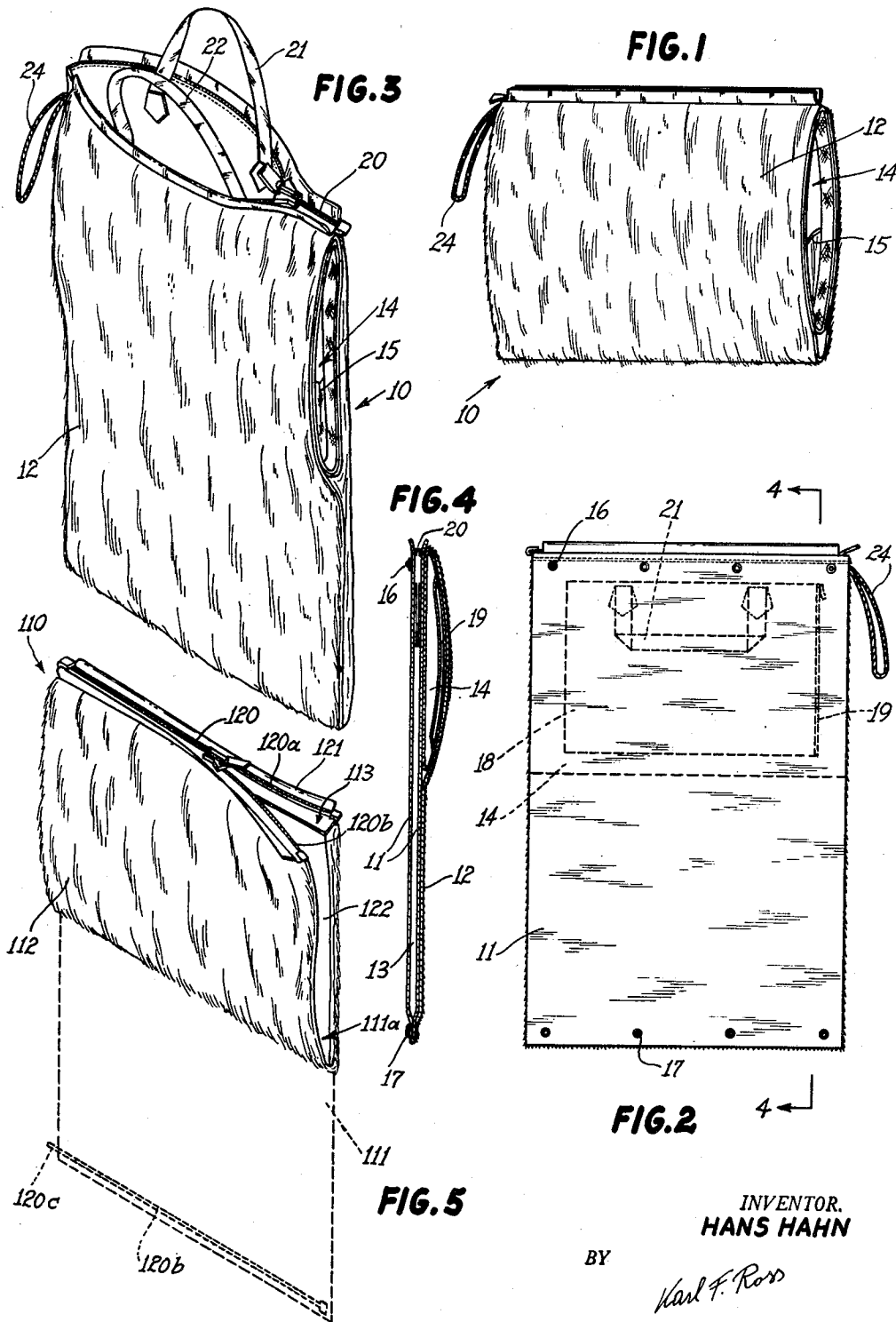

INVENTOR.
HANS HAHN
BY
Karl F. Ross
AGENT

UNITED STATES PATENT OFFICE

2,557,280

COMBINATION MUFF AND SHOPPING BAG

Hans Hahn, New York, N. Y., assignor of one-half
to Hans Meinhardt, New York, N. Y.

Application October 12, 1948, Serial No. 54,137

2 Claims. (Cl. 2-66)

1

The present invention relates to a new article of manufacture representing a combination muff and shopping bag.

An object of my invention is to provide an article of apparel having the dual function of serving as a protection for the hands of the user in cold weather and as a receptacle for all kinds of merchandise.

Another object of the invention is to provide a muff incorporating a handbag of conventional size which is quickly and conveniently convertible into a shopping bag of at least double the size and capacity of the handbag.

A further object of this invention is to provide, as a new article of manufacture, a muff bag having a first compartment extending substantially through the entire bag and a second compartment extending through not more than half of said bag, whereby, upon trimming of the bag with fur or other suitable material, a muff of conventional appearance but convertible into a shopping bag will be formed.

The above and other objects of the invention will become apparent from the following description, reference being had to the accompanying drawing in which:

Fig. 1 is a front view of the new article of manufacture according to the invention, used as a muff;

Fig. 2 is a rear view of the article shown in Fig. 1, in unfolded condition and ready to be used as a shopping bag;

Fig. 3 is a perspective front view of the article in unfolded condition;

Fig. 4 is a section taken on the line 4-4 of Fig. 2; and

Fig. 5 is a perspective front view of a modified article according to the invention, shown in folded and partly closed condition.

The new article of manufacture, indicated generally at 10, comprises, essentially, a muff bag 11 (Fig. 4) lined on one side with a suitable material 12, preferably fur. The bag 11 is provided with a first compartment 13, extending substantially throughout the entire length thereof, and a second, considerably smaller compartment 14. The latter compartment, as will be readily understood, is adapted to receive the hands and arms of the user when the article serves as a muff, having been folded in half as shown in Fig. 1. Compartment 14 is open at the sides and may be provided with conventional windshields 15, designed to close up the lower part of each side opening while just permitting passage of the arm of the user. To hold the

2

article in its folded condition, the back of the bag 11 is provided (in the embodiment illustrated in Figs. 1 through 4) with a row of male snap fasteners 16 and a row of cooperating female fasteners 17.

A third compartment 18, accessible through a zipper 19, may be provided in one of the walls of the muff compartment 14.

The compartment 13 may be closed at the top by a zipper 20, as best seen in Fig. 3. It will be understood that the upper half of this compartment will also be usable when the article is worn as a muff, this half having a volume comparable with that of a handbag; compartment 13 also contains a pair of handles or straps 21, 22 which rest folded within the compartment, as shown in dotted lines in Fig. 2, except when the article is used as a shopping bag. In the latter event the handles 21, 22 will be pulled out in the manner shown in Fig. 3, thereby permitting the bag to be filled with merchandise to be carried in open condition without danger of spilling its contents.

A loop 24 serves for the convenient carrying of the article in its folded or in its unfolded but empty condition.

In the modification of Fig. 5, the article 110 is generally similar to that shown in the preceding figures but the snap fasteners 16, 17 have been dispensed with, a zipper 120 serving both as a closure means for the compartment 113 and as a means for keeping the article in its folded condition (shown in full lines in Fig. 5). Zipper 120 is of the open type, having one half 120a secured to the upper edge of the front wall 121 of the muff bag 111 and having another half 120b secured to the lower edge of the rear wall 122 of the bag, assuming the same to be in the unfolded condition shown in dotted lines in Fig. 5. The two halves are readily separable, as shown, zipper half 120b being provided with a tag 120c to facilitate reassembly. It will also be seen that wall 122 is somewhat shorter than wall 121, in order to terminate below zipper 120.

It will be understood that the muff bag 111 may be provided with a compartment (not visible in Fig. 5) similar to compartment 14, Figs. 1-4; on the other hand it will also be possible to use the compartment 111a, formed by folding the bag 111, as the muff compartment.

While the invention has been described with reference to certain embodiments, the same have been given merely by way of illustration and not as a limitation upon the scope of the invention. More particularly, it is to be understood that the material of the front piece 12, Figs. 1-4, or 112,

Fig. 5, need not be fur but may comprise any suitable and ornamental or heat-insulating fabric or other material, and that the various fastener devices shown may be replaced by other, equivalent devices of different construction.

What I claim as novel, and desire to secure by Letters Patent, is:

1. As a new article of manufacture, a muff bag horizontally foldable in the center and provided with a first compartment extending substantially through the full length thereof and with a second compartment extending through not more than one half thereof, said first compartment being open at the top, said second compartment being open at the sides, said muff bag being further provided with fastening means for keeping the bag in folded condition, said muff bag when in said folded condition forming a third compartment substantially coextensive with said second compartment.

2. A muff bag horizontally foldable in the center and provided with a first compartment extending substantially through the full length

thereof and with a second compartment extending through not more than one half thereof, said first compartment being open at the top, said second compartment being open at the sides, said muff bag being further provided at the top and at the bottom with fastening means for keeping the bag in folded condition, said muff bag when in folded condition forming a third compartment open at the sides and substantially coextensive with said second compartment.

HANS HAHN.

REFERENCES CITED

The following references are of record in the file of this patent:

UNITED STATES PATENTS

Number	Name	Date
1,672,322	Keiser et al.	June 5, 1928
1,817,750	Lipschutz	Aug. 4, 1931
2,086,326	Goldberg	July 6, 1937
2,412,007	Plapler	Dec. 3, 1946