

W. N. JACKSON.
Thrashing Machine.

No. 111,848.

Patented Feb. 14, 1871.

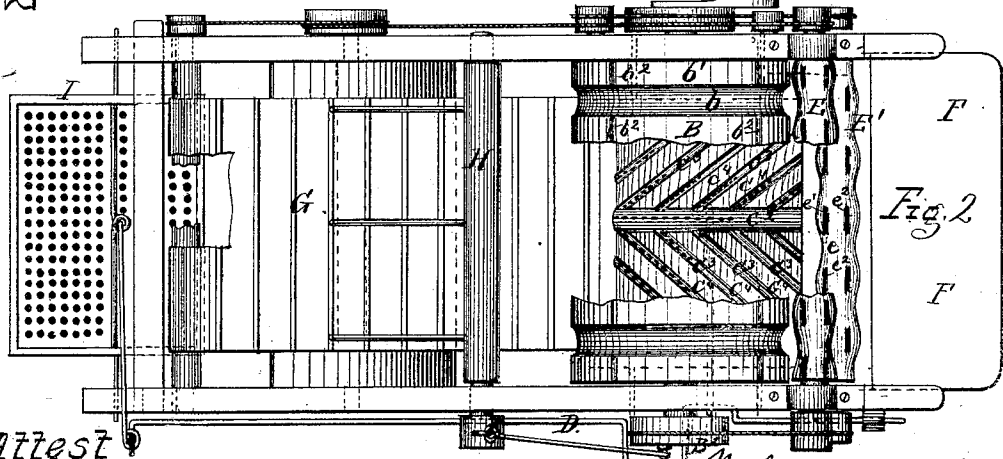
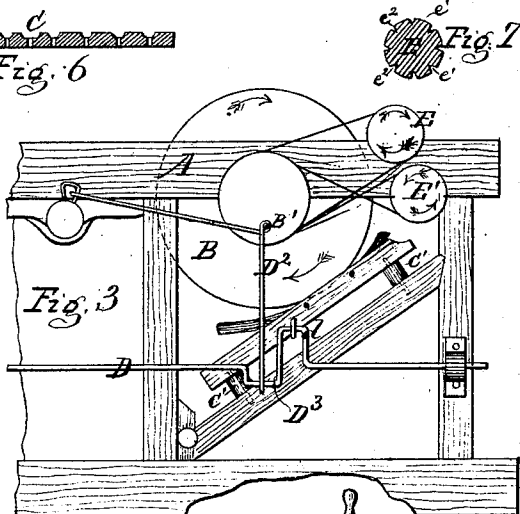
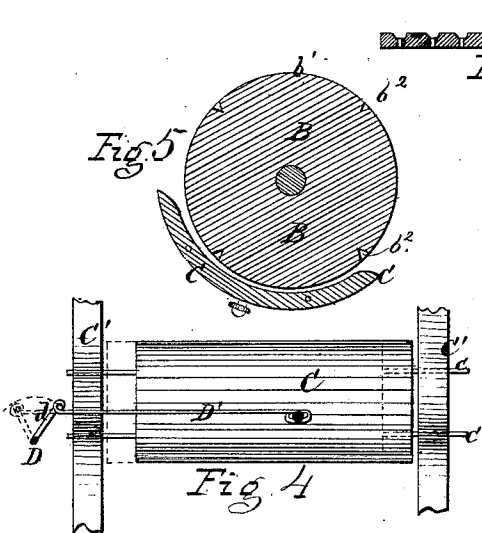
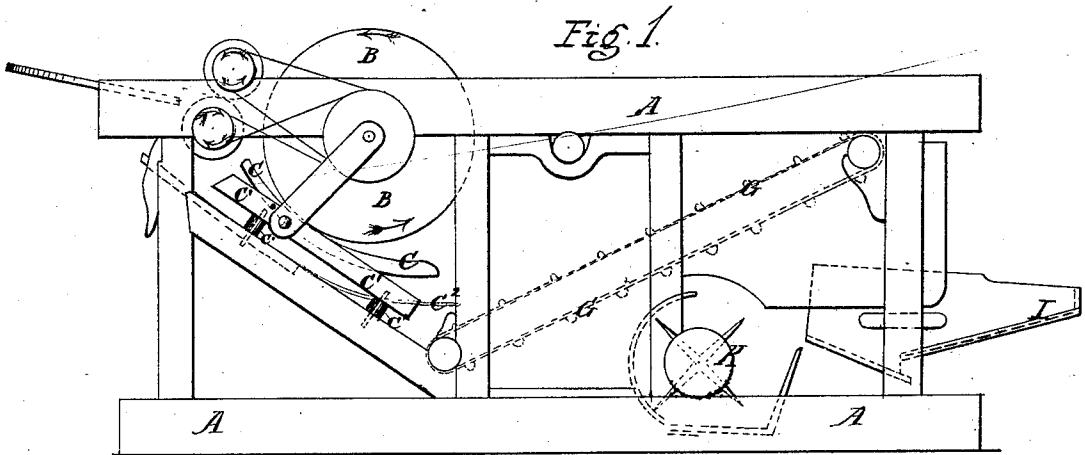

Attest
C. Blawie
A. Ruppert

W. N. Jackson
Inventor
D. P. Holloway & Co
1871

United States Patent Office.

WILLIAM N. JACKSON, OF MUNCIE, ASSIGNOR TO HIMSELF AND BENJAMIN F. JACKSON, OF ANDERSON, INDIANA.

Letters Patent No. 111,848, dated February 14, 1871.

IMPROVEMENT IN THRASHING-MACHINES.

The Schedule referred to in these Letters Patent and making part of the same.

To all whom it may concern:

Be it known that I, WILLIAM N. JACKSON, of Muncie, in the county of Delaware and State of Indiana, have invented certain Improvements in Thrashing-Machines; and I do hereby declare that the following is a full, clear, and exact description thereof, reference being had to the annexed drawing making part this specification, in which—

Figure 1 is a side elevation of a thrashing-machine embodying my improvements.

Figure 2 is a plan view, with part of the thrashing-cylinder and upper feed-roller broken away to show the construction of the vibrating concave.

Figure 3 is a side elevation of a detached portion of the machine, showing the side opposite to that illustrated in fig. 1.

Figure 4 is a front view of the vibrating concave.

Figure 5 is a vertical transverse section of the thrashing-cylinder and concave.

Figure 6 is a vertical section of the concave.

Figure 7 is a transverse section of one of the feed-rollers.

The same letters are used in all the figures in the designation of identical parts.

This invention relates to a thrashing-machine more especially designed for thrashing flax, but applicable also for thrashing other seed and grain.

My improvement consists—

First, in the construction and arrangement of the concave, which is formed upon its upper surface with one wide central groove and a number of diagonal grooves and ribs upon each side of the central groove, the diagonal grooves and ribs on one side running at an angle to those on the other side, and has a reciprocating motion lengthwise of the axis of the thrashing-cylinder, to obtain a rubbing action upon the material passing between them.

Secondly, in the construction of the thrashing-cylinder and the feed-rollers.

To enable those skilled in the art to make and use my invention, I will proceed to describe its construction and operation.

The various operative parts of the machine are mounted upon a substantial frame, A, at one end of which the thrashing-cylinder B is arranged in suitable journal-boxes.

The cylinder may be made of any suitable material, and balanced in the usual way to insure a uniform movement thereof.

The surface of the cylinder is formed with alternate grooves *b* and elevations *b'*, running around it at right angles to its axis; and notches *b''* are cut in the elevations *b'* lengthwise, at certain intervals, to feed the material forward as it is being thrashed between the concave and the cylinder.

The concave C is somewhat shorter than the cylinder,

and has at each end two guide-rods, *c*, by which it is supported in bearings in the inclined bars C¹, which, in turn, are seated upon springs *c'*, attached to the frame-work in the manner shown.

The springs bearing against the under side of the supporting-bars C¹ of the concave exert a constant upward pressure upon the latter, and thus aid materially in the thrashing of the flax, while they, at the same time, will yield sufficiently to permit any hard substances to pass between the cylinder and concave without damage to any part of the machine.

In the upper surface of the concave a central groove, *c''*, of considerable width comparatively, is formed, and on each side of this central groove is a number of diagonal grooves, *c'''*, and ribs *c''''*.

The diagonal grooves and ribs on one side of the central groove run at an angle to those on the other side, and the two sets converge toward the lower or discharging side of the concave, to direct the seed which enters the diagonal grooves downward into the central groove, from which it falls upon the incline C², and finally upon the carrier-apron.

The lower portion of the concave in the diagonal grooves and central groove is perforated, so that the seed can fall through upon the incline C² below it, and avoid any choking at the discharging side of the concave.

Upon reference to fig. 4 it will be seen that the space between the bars C¹ is longer than the concave, to permit of a reciprocating movement of the latter in the direction of the length of the cylinder. By thus giving the corrugated concave a reciprocating motion under the corrugated revolving cylinder, a rubbing action upon the material passing between them is obtained, whereby the seed is thrashed out more thoroughly than can possibly be done by a machine in which a stationary concave is employed. The reciprocating motion may be imparted to the concave in any preferred manner.

As illustrated in the drawing, it receives this motion from a rock-shaft, D, arranged upon the side of the frame, and provided with a crank at *d*, which is connected by a rod, D¹, to the under side of the concave.

The rock-shaft is oscillated by a crank, B¹, on the cylinder-shaft, through the medium of a connecting-rod, D², and crank or arm D³ on the rock-shaft, in the manner shown.

E and E¹ represent the feed-rollers, resting in bearings on the frame in front of the thrashing-cylinder.

One of these rollers should be arranged to have a bodily vertical motion, to accommodate itself to the amount of flax or grain passing through the pair. They may be operated from the driving-pulley of the cylinder, as shown,

The surface of each roller is formed with alternate

annular grooves e and elevations e' , and the rollers are so arranged with reference to each other that the elevations of one mesh into the grooves of the other, as indicated in fig. 2.

To enable the rollers to take a better hold of the straw in feeding it, series of notches e'' are cut in the elevations e' lengthwise of the rollers, and the notches in one roller should be made to come opposite the blank spaces in the other at the "bite" of the rollers.

The flax, grain, &c., is fed between the rollers from table F, and after the seed has been thrashed out between the cylinder and vibrating concave, the straw and seed are delivered upon the inclined carrier-apron G, constructed with the ordinary cross-slats.

Above the carrier-apron a whipper, H, is arranged, composed of a horizontal shaft, with several curved flexible teeth or arms.

The shaft is oscillated by the crank of the cylinder-shaft through a pitman, causing the arms to whip the straw passing under it and cause the seed to fall upon the apron.

The straw is discharged from the rear end of the machine, while the seed and chaff, &c., fall from the apron, to be cleaned and separated by the vibrating screen I and fan K in the usual manner.

These parts form no part of my present invention, and may, therefore, be sufficiently understood, as they are in common use, by reference to the drawing.

What I claim as my invention, and desire to secure by Letters Patent, is—

1. The concave C, constructed with a central groove, e'' , and a set of parallel diagonal grooves, e' , and ribs e' on each side of the central groove, such sets converging toward the discharging side of the concave, substantially as set forth.

2. In combination with the thrashing-cylinder of a thrashing-machine, a concave having a reciprocating motion parallel to the axis of the cylinder, substantially as set forth.

3. The combination of the vibrating concave C, constructed as described, and the cylinder B, having alternate annular grooves b and elevations b' , and longitudinal serrations b'' , substantially as set forth.

4. The combination of the feed-rollers E and E' and thrashing-cylinder B, when severally constructed, with the alternate annular grooves b and e and elevations b' and e' , and longitudinal serrations b'' and e'' , as shown and described.

In testimony whereof I have signed my name to this specification in the presence of two subscribing witnesses.

W. N. JACKSON.

Witnesses:

D. P. HOLLOWAY,
B. EDW. J. ELLS.