

B. A. BROOKS.

RIBBON FEED MECHANISM FOR TYPE WRITERS.

(Application filed May 19, 1900.)

(No Model.)

4 Sheets—Sheet 1.

Fig. 1.

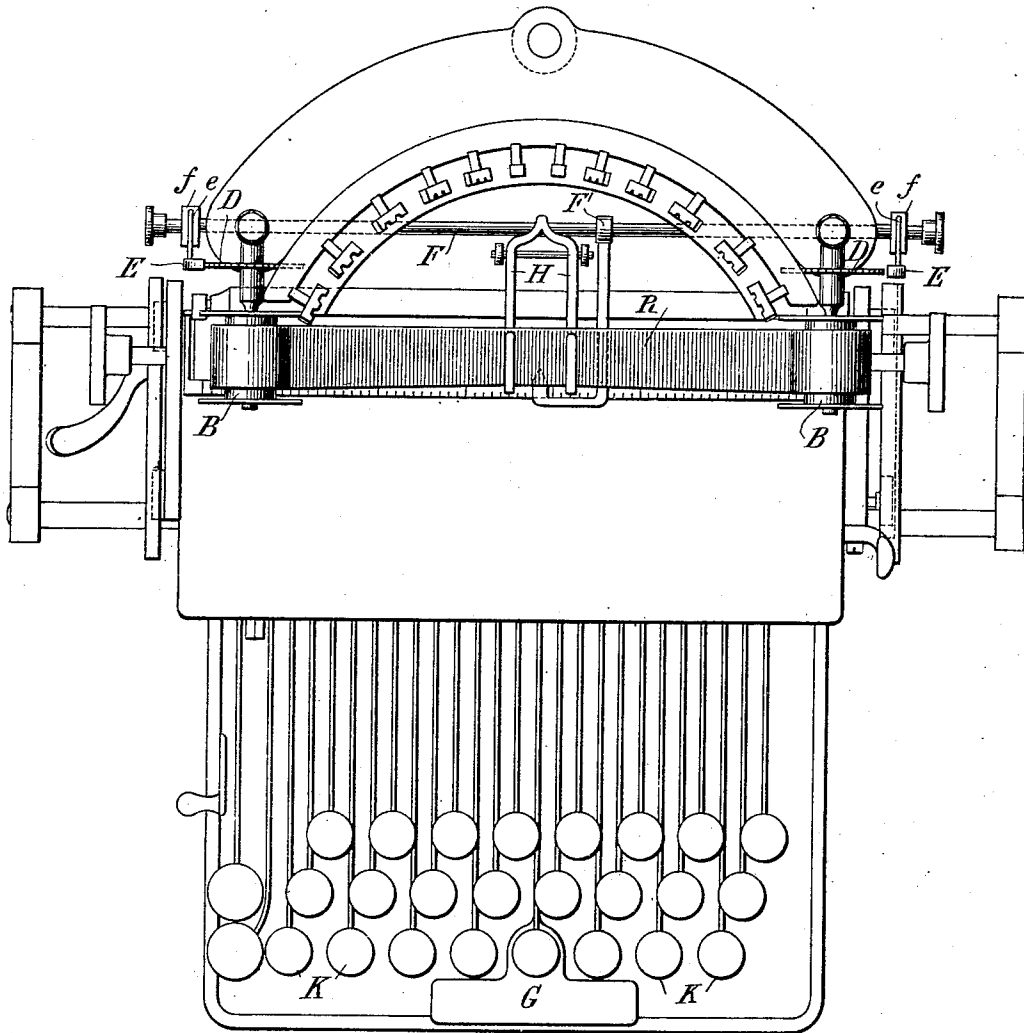

WITNESSES:

L. E. Ashley
H. L. Reynolds

INVENTOR:

B. A. Brooks
 By his Attorneys
Jeffers & Puel

B. A. BROOKS.
RIBBON FEED MECHANISM FOR TYPE WRITERS.

(Application filed May 19, 1900.)

(No Model.)

4 Sheets—Sheet 2

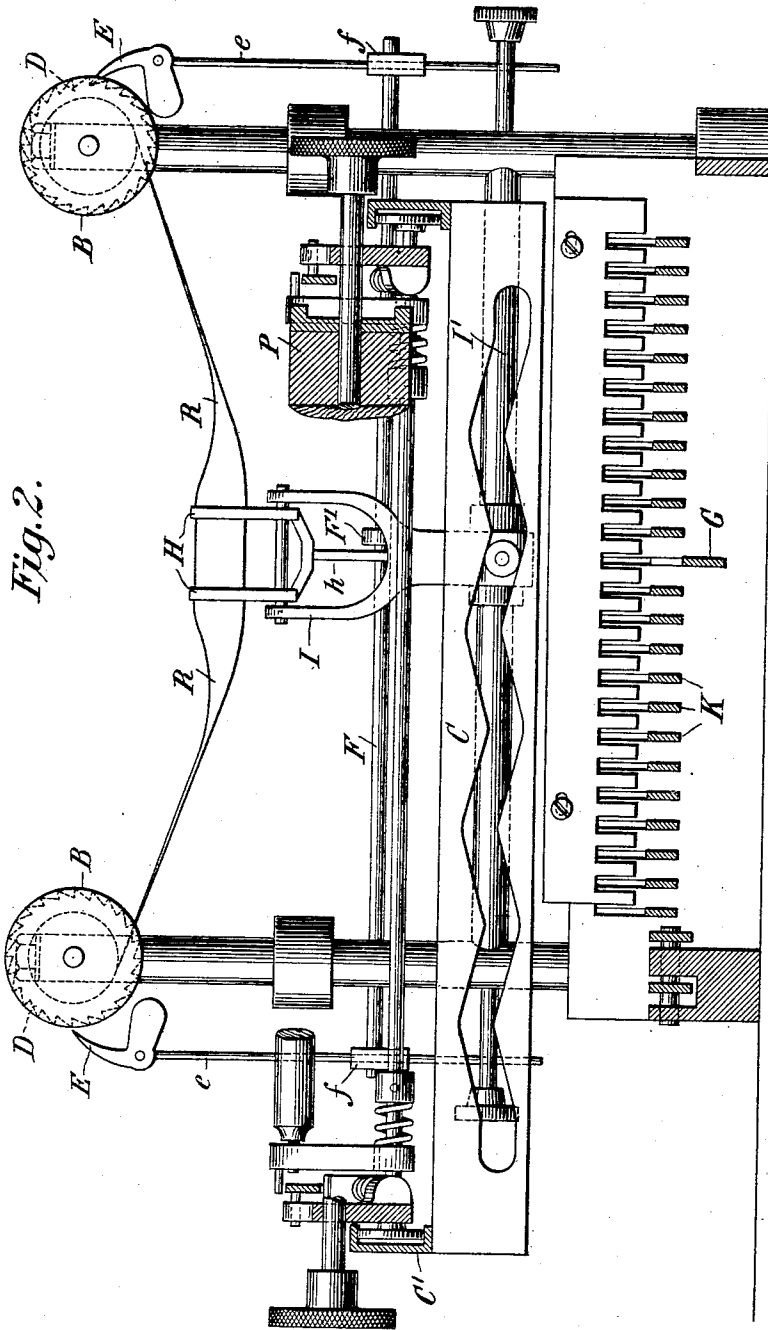

Fig. 2.

WITNESSES:
C. E. Ashley
H. L. Reynolds

INVENTOR:
Byron A. Brooks.
 By his Attorney
Arthur P. Hill

B. A. BROOKS.

RIBBON FEED MECHANISM FOR TYPE WRITERS.

(Application filed May 19, 1900.)

(No Model.)

4 Sheets—Sheet 2.

Fig. 4.

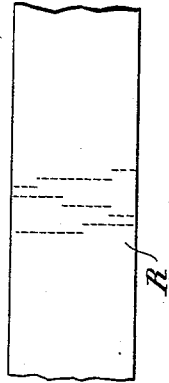
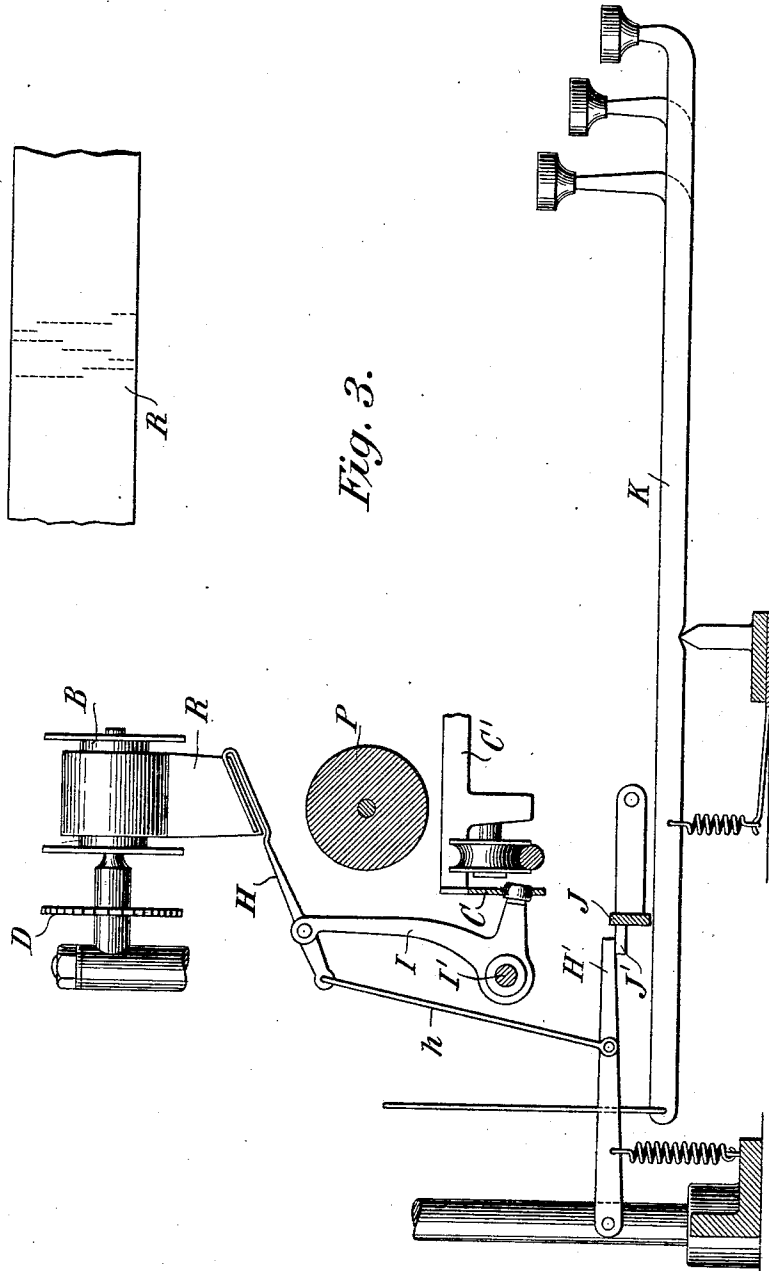

Fig. 3.



WITNESSES:

C. E. Ashley
H. L. Reynolds

INVENTOR:

Byron A. Brooks.
By his Attorney
Clifford & Pull

No. 677,III.

Patented June 25, 1901.

B. A. BROOKS.

RIBBON FEED MECHANISM FOR TYPE WRITERS.

(Application filed May 19, 1900.)

(No Model.)

4 Sheets—Sheet 4.

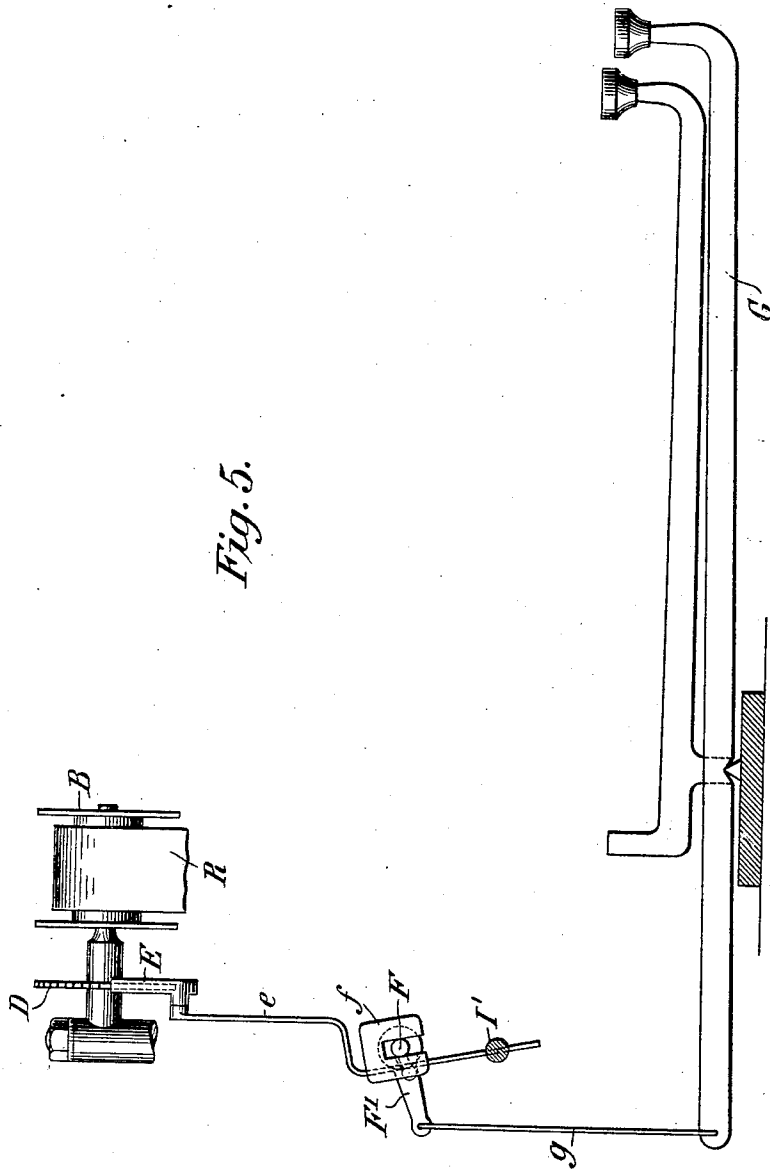

WITNESSES:

C. E. Ashley
H. L. Reynolds

INVENTOR:

Byron A. Brooks
By his Attorneys
Gifford & Hill

UNITED STATES PATENT OFFICE.

BYRON A. BROOKS, OF BROOKLYN, NEW YORK, ASSIGNOR TO UNION TYPE-WRITER COMPANY, OF NEW JERSEY.

RIBBON-FEED MECHANISM FOR TYPE-WRITERS.

SPECIFICATION forming part of Letters Patent No. 677,111, dated June 25, 1901.

Original application filed April 26, 1894, Serial No. 509,086. Divided and this application filed May 19, 1900. Serial No. 17,185. (No model.)

To all whom it may concern:

Be it known that I, BYRON A. BROOKS, a citizen of the United States, and a resident of New York city, (borough of Brooklyn,) in the county of Kings and State of New York, have invented a new and Improved Ribbon-Feed Mechanism for Type-Writers, of which the following is a full, clear, and exact description.

10 My invention consists of novel means for operating the ribbon of type-writers, and comprises certain novel parts and combinations of parts, which will be hereinafter described, and particularly pointed out in the
15 claims.

Reference is to be had to the accompanying drawings, forming a part of this specification, in which similar characters of reference indicate corresponding parts in all the figures.

20 Figure 1 is a plan view of a portion of a type-writer, showing my device applied thereto. Fig. 2 is a sectional elevation of a type-writer with my device attached. Fig. 3 is a sectional side elevation of parts of the type-
25 writer, illustrating my device. Fig. 4 shows in diagrammatic form the manner of using the surface of the ribbon in printing the letters, and Fig. 5 is a sectional side elevation showing the ribbon-feeding device.

30 The following is a description of the construction shown in the accompanying drawings, the same illustrating the form which is at present preferred by me, although it is possible to change the construction of many
35 of these parts without essentially altering the invention.

This application is a division of application Serial No. 509,086, filed by me on the 26th day of April, 1894.

40 The inking-ribbon R herein shown is wound upon two spools B, located as in the ordinary type-writer, and said spools are provided with turning mechanisms, by which the ribbon is gradually shifted from one to the other by
45 the operation of the machine. This ribbon is interposed between the types and the platen and vibrates toward and from the platen at each printing impulse. This is accomplished by means of a fork H, which is

pivoted to a rocking lever I, said lever being 50 fulcrumed upon a rod I'. One end of the ribbon-fork is connected by means of a link h with an arm or lever H', which is engaged by a projection J', extending from a bar J, which extends across the machine and just
55 above the key-levers K, so that by the operation of any one of the key-levers the bar J is elevated, thus forcing upward the link h, and thus throwing the ribbon downward, or toward the platen P. The ribbon is also given
60 a motion transversely of the platen by vibrating the bell-crank lever I, to which the fork H is pivoted. This is herein shown as accomplished by means of a cam which engages
65 the lower or horizontal arm of the bell-crank lever, so as to give it a vibrating movement while the carriage is traveling across the machine. This cam is herein shown as consisting of a plate C, which is secured to the carriage C' and is provided with a zigzag slot, so
70 that the lever I is given a series of reciprocations during the printing of a line. Various other forms of cams may be substituted for that shown—as, for instance, the lower portion of the bar may be cut away and the lever
75 be held to the upper surface of the slot by a spring. The action of the type upon the ribbon is diagrammatically illustrated in Fig. 4, in which the dotted lines show the impressions made upon the ribbon in producing the
80 letters forming the various words. Each line of dots represents the letters of a word, the ribbon being shifted longitudinally or by the operation of the drums B between each word-through the action of the space-key. The
85 manner in which this is accomplished is shown in Fig. 5. The drums B have each a ratchet-wheel D attached thereto in any convenient manner and operated upon by a pawl E. This pawl is carried upon a rod or link e,
90 which is connected with a collar f, mounted upon a rod F, which extends transversely of the machine. The rod F has an arm F' secured thereto and connected by means of a link g with one end of the space-lever G, so
95 that whenever the space-key is operated the rod or rock-shaft F is vibrated, so as to operate the pawl E and turn the ratchet-wheel D

through the space of one tooth. The collar *f* is secured to the rock-shaft F by means of a slot in the shaft and a pin in the collar, so that the collar may be moved upon the shaft.

5 In the foregoing specification I have shown a form of construction which is at present preferred by me; but I do not, however, wish to be limited to this construction only, as it is possible to change the form of many of the
10 parts by the substitution of substantial equivalents without exceeding the scope of the claims. In the claims the omission of an element or the omission of a reference to the detail features of the elements mentioned is intended to be a formal declaration of the fact
15 that the omitted elements or features are not essential to the inventions therein severally covered.

Having thus fully described my invention,
20 I claim as new and desire to secure by Letters Patent—

1. In a type-writing machine, the combination of a ribbon-holder, a platen-carriage, a
25 plurality of cam-surfaces attached to said carriage for causing said ribbon-holder to move transversely both ways during the operation of printing and suitable connecting mechanism between said cam and said ribbon-holder.

2. In a type-writing machine the combination of a ribbon-holder, a platen-carriage, a
30 plurality of cam-surfaces attached to said carriage for causing said ribbon-holder to move transversely both ways during the operation of printing, suitable connecting mechanism between said cam and said ribbon-
35 holder, a plurality of ribbon-spools and means for causing said spools to feed the ribbon longitudinally.

3. In a type-writing machine the combination of a plurality of ribbon-spools, pawl-and-
40 ratchet mechanism for rotating said spools, a vibrating ribbon-holder, a ribbon operating-bar connected with the type-keys and with said ribbon-holder, a space-key and connections between the space-key and the pawl-and-
45 ratchet mechanism independent of the type-keys whereby the ribbon is fed forward when the space-key is operated but not when the type-keys are operated.

4. In a type-writing machine, a ribbon-
50 holder means for vibrating said holder to and from the platen during the operation of printing to expose the print and means for vibrating said holder transversely to the line being
55 printed.

5. In a type-writing machine, the combination of a vibrating ribbon-holder, means for vibrating said holder to expose the print, means for reciprocating said holder trans-
60 versely during the operation of printing and means for feeding the ribbon longitudinally.

6. In a type-writing machine the combination of a platen, an inking-ribbon, means for vibrating said ribbon to and from the print-
65 ing-point to expose the print and means for feeding the ribbon transversely to the line of print during the operation of printing.

7. In a type-writing machine, the combination of a platen, a ribbon, a universal bar operated by the key-levers and a ribbon-oper-
70 ating bar by which the ribbon is vibrated to and from the printing-point at each impression of the types.

8. In a type-writing machine, the combination of a platen, a vibrating ribbon-holder, a
75 bell-crank lever by which said holder is vibrated and a cam whereby said lever is operated and the ribbon is reciprocated transversely to the line of print, during the forward movement of the carriage in the oper-
80 ation of printing.

9. In a type-writing machine, the combination of a platen, type-bars set in the arc of a circle to strike at a common printing-point in
85 view of the operator, a scale or pressure bar capable of being moved to or from the surface of the platen, a vibrating ribbon-holder and means for vibrating said holder to and from the printing-point by the operation of
90 the key-levers.

10. In a type-writing machine, the combination with means for moving an inking-ribbon
widthwise of means for moving the ribbon lengthwise connected to and operated by the
95 space-key of a carriage spacing mechanism whereby during the writing of a word the ribbon is moved widthwise and during the spacing between words the ribbon is moved length-
wise.

11. In a type-writing machine, the combination of an inking-ribbon, a longitudinally-
100 traveling paper-carriage, means attached to said carriage whereby the ribbon is moved back and forth transversely to the line of print during the forward movement of the car-
105 riage in the operation of printing and means for feeding the ribbon longitudinally.

12. In a type-writing machine the combination of ribbon-spools mounted on shafts fixed
110 to the frame of the machine, a ribbon-holder intermediate between said spools through which said ribbon passes and means actuated by the movement of the platen-carriage for
115 automatically moving said ribbon at the point of impression at an angle transversely to the line of print to present a new surface to the
type.

13. In a visible-writing machine, the combination with a ribbon normally removed from
120 and disclosing the printing-point, of means for automatically moving the ribbon crosswise over said printing-point, whereby the ribbon is used transversely of its length.

14. In a visible-writing machine, the combination with a ribbon normally removed from
125 and disclosing the printing-point, of means for automatically moving the ribbon crosswise over said printing-point during the operation of the character-keys one after another.

15. In a visible-writing machine, the combination with a ribbon normally removed from
130 and disclosing the printing-point, of means for automatically moving the ribbon crosswise over said printing-point, whereby the ribbon

is used transversely of its length, and means for moving said ribbon in a lengthwise direction.

5 16. In a visible-writing machine, the combination with a ribbon which normally stands away from and exposes the printing-point, of means for moving the ribbon so as to cover and uncover the printing-point at each action of the character-keys and means for causing the

ribbon to have a reciprocatory step-by-step 10 widthwise movement relatively to the printing-point, so that different transverse portions thereof cover the printing-point when the type impressions are made.

BYRON A. BROOKS.

Witnesses:

H. L. REYNOLDS,
CHARLES J. RATHJEN.