



US010287513B2

(12) **United States Patent**  
**MacDonald**

(10) **Patent No.:** **US 10,287,513 B2**  
(45) **Date of Patent:** **May 14, 2019**

(54) **METHOD AND APPARATUS FOR RECOVERING SYNTHETIC OILS FROM COMPOSITE OIL STREAMS**

21/20 (2013.01); C10G 21/24 (2013.01); C10G 45/04 (2013.01); C10G 53/06 (2013.01); C10G 53/08 (2013.01); C10G 67/04 (2013.01); C10G 67/14 (2013.01); C11B 3/006 (2013.01); C10G 2300/1007 (2013.01);  
(Continued)

(71) Applicant: **PNG Gold Corporation**, Vancouver (CA)

(58) **Field of Classification Search**  
None  
See application file for complete search history.

(72) Inventor: **Martin R. MacDonald**, Plano, TX (US)

(73) Assignee: **Gen III Oil Corporation**, Vancouver (CA)

(56) **References Cited**

(\*) Notice: Subject to any disclaimer, the term of this patent is extended or adjusted under 35 U.S.C. 154(b) by 0 days.

U.S. PATENT DOCUMENTS

2,541,338 A \* 2/1951 Clarke ..... C10G 73/06 208/24  
3,173,859 A 3/1965 Chambers  
(Continued)

(21) Appl. No.: **15/416,069**

FOREIGN PATENT DOCUMENTS

(22) Filed: **Jan. 26, 2017**

WO 2006/096396 9/2006

(65) **Prior Publication Data**

US 2017/0130143 A1 May 11, 2017

OTHER PUBLICATIONS

**Related U.S. Application Data**

U.S. Appl. No. 15/428,195 Office Action dated Apr. 5, 2018.  
(Continued)

(63) Continuation of application No. 14/201,095, filed on Mar. 7, 2014, which is a continuation of application No. 14/169,113, filed on Jan. 30, 2014.  
(Continued)

*Primary Examiner* — Tam M Nguyen  
(74) *Attorney, Agent, or Firm* — MBM Intellectual Property Law LLP

(51) **Int. Cl.**  
C10G 53/04 (2006.01)  
C07C 5/02 (2006.01)  
(Continued)

(57) **ABSTRACT**

A method for recovering synthetic oils from a feed stream, the method comprising separating at least a portion of the non-synthetic oil constituents from a commingled stream to produce a partially purified synthetic oil stream and one or more contaminant streams. Extracting at least a portion of the synthetic oil from the partially purified synthetic oil stream to produce a synthetic oil stream and a second contaminant stream.

(52) **U.S. Cl.**  
CPC ..... C10G 53/04 (2013.01); C07C 5/02 (2013.01); C07C 7/005 (2013.01); C10G 7/00 (2013.01); C10G 7/003 (2013.01); C10G 7/006 (2013.01); C10G 21/006 (2013.01); C10G 21/02 (2013.01); C10G 21/16 (2013.01); C10G 21/18 (2013.01); C10G

**17 Claims, 3 Drawing Sheets**

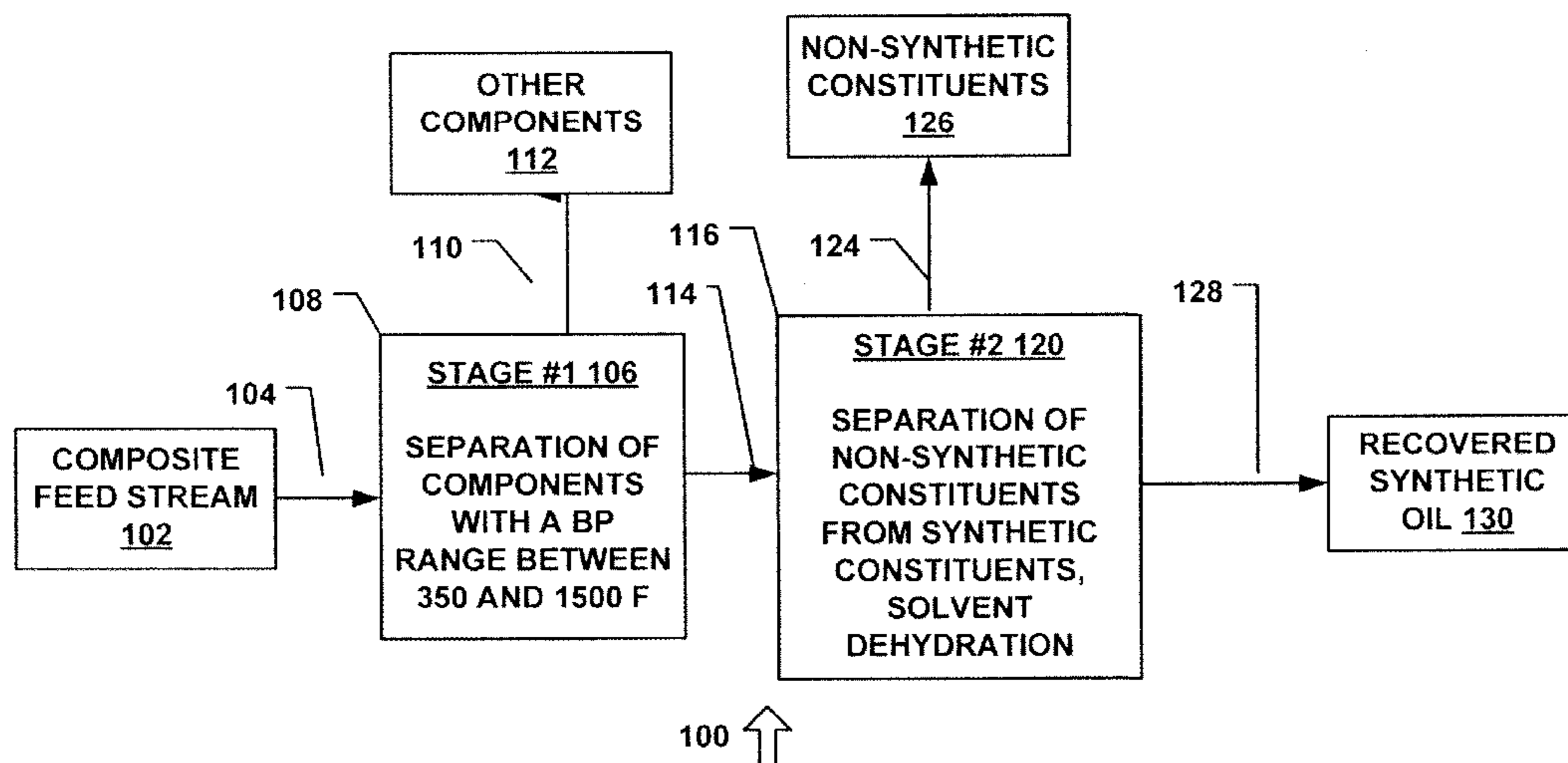

<b>Related U.S. Application Data</b>					
(60)	Provisional application No. 61/744,027, filed on Mar. 7, 2013, provisional application No. 61/774,037, filed on Mar. 7, 2013.			5,707,510 A	1/1998 Berry
				5,759,385 A	6/1998 Aussillous et al.
				5,795,462 A	8/1998 Shurtleff
				5,814,207 A	9/1998 Kenton
				5,871,618 A	2/1999 Lee et al.
				5,885,444 A	3/1999 Wansborough et al.
				5,904,838 A	5/1999 Kalnes et al.
(51)	<b>Int. Cl.</b>			5,980,698 A	11/1999 Abrosimov et al.
	<i>C07C 7/00</i> (2006.01)			6,007,701 A	12/1999 Sherman et al.
	<i>C10G 21/16</i> (2006.01)			6,106,699 A	8/2000 MacDonald et al.
	<i>C10G 21/18</i> (2006.01)			6,117,309 A *	9/2000 Daspit ..... C10M 175/005 208/184
	<i>C10G 21/20</i> (2006.01)			RE36,922 E	10/2000 Sparks et al.
	<i>C10G 21/24</i> (2006.01)			6,132,596 A	10/2000 Yu
	<i>C10G 45/04</i> (2006.01)			6,174,431 B1	1/2001 Williams et al.
	<i>C10G 67/04</i> (2006.01)			6,179,999 B1	1/2001 Sherman et al.
	<i>C10G 67/14</i> (2006.01)			6,238,551 B1	5/2001 Sherman et al.
	<i>C10G 21/02</i> (2006.01)			6,292,737 B1	9/2001 Higashimata et al.
	<i>C10G 7/00</i> (2006.01)			6,319,394 B2	11/2001 Sherman et al.
	<i>C10G 21/00</i> (2006.01)			6,320,090 B1	11/2001 Sherman et al.
	<i>C10G 53/06</i> (2006.01)			6,372,122 B1	4/2002 Gorman
	<i>C10G 53/08</i> (2006.01)			6,398,948 B1	6/2002 Sherman et al.
	<i>C11B 3/00</i> (2006.01)			6,402,937 B1	6/2002 Shaffer, Jr. et al.
(52)	<b>U.S. Cl.</b>			6,440,298 B1	8/2002 Shurtleff
	CPC ..... <i>C10G 2300/44</i> (2013.01); <i>C10G 2400/22</i> (2013.01); <i>C10G 2400/30</i> (2013.01)			6,512,147 B2	1/2003 Inaba et al.
				6,592,748 B2	7/2003 Cody et al.
				RE38,366 E	12/2003 Kenton
				6,712,954 B1	3/2004 Pohler et al.
				6,713,438 B1 *	3/2004 Baillargeon ..... C10M 111/04 508/463
(56)	<b>References Cited</b>			6,805,062 B2	10/2004 Shurtleff
	<b>U.S. PATENT DOCUMENTS</b>			6,806,237 B2	10/2004 O'Rear ..... 508/110
	3,625,881 A	12/1971	Chambers	6,929,737 B2	8/2005 Sherman et al.
	3,923,644 A	12/1975	Hindman	7,226,533 B2	6/2007 Aramburu
	4,021,333 A	5/1977	Habiby et al.	7,261,808 B2	8/2007 Grandvallet et al.
	4,033,859 A	7/1977	Davidson et al.	7,267,760 B2	9/2007 Sherman et al.
	4,071,438 A	1/1978	O'Blasny	8,366,912 B1 *	2/2013 MacDonald ..... C10G 71/00 208/184
	4,101,414 A	7/1978	Kim et al.	2001/0001198 A1	5/2001 Sherman et al.
	4,151,072 A	4/1979	Nowack et al.	2001/0022281 A1	9/2001 Sherman et al.
	4,169,044 A	9/1979	Crowley	2001/0025807 A1	10/2001 Sherman et al. .... 208/181
	4,233,140 A	11/1980	Antonelli et al.	2002/0036158 A1	3/2002 Austin
	4,302,325 A	11/1981	Fletcher et al.	2004/0011704 A1	1/2004 Shurtleff
	4,342,645 A	8/1982	Fletcher et al.	2005/0006282 A1	1/2005 Grandvallet et al.
	4,360,420 A	11/1982	Fletcher et al.	2008/0000808 A1	1/2008 Sherman et al.
	4,399,025 A	8/1983	Fletcher et al.	2011/0278151 A1	11/2011 MacDonald ..... 203/12
	4,431,524 A	2/1984	Norman	2011/0287988 A1	11/2011 Fisher et al. .... 508/110
	4,432,856 A	2/1984	Norman	2014/0257008 A1	9/2014 MacDonald ..... 585/802
	4,512,878 A	4/1985	Reid et al.		
	4,894,140 A	1/1990	Schon		
	4,941,967 A	7/1990	Mannetje et al.		
	5,028,313 A	7/1991	Kalnes et al.		
	5,045,179 A	9/1991	Langhoff et al.		
	5,049,258 A	9/1991	Keim et al.		
	5,102,531 A	4/1992	Kalnes et al.		
	5,143,597 A	9/1992	Sparks et al.		
	5,242,579 A	9/1993	Mead et al.		
	5,244,565 A	9/1993	Lankton et al.		
	5,302,282 A	4/1994	Kalnes et al.		
	5,306,419 A	4/1994	Harrison et al.		
	5,362,381 A	11/1994	Brown et al.		
	5,382,328 A	1/1995	Drespa et al.		
	5,384,037 A	1/1995	Kalnes		
	5,447,625 A	9/1995	Harrison et al.		
	5,632,867 A	5/1997	Davis et al.		

**OTHER PUBLICATIONS**

Canadian Patent Office; Office Action; Canadian Application No. 2,845,176; dated May 14, 2014, 2 pages.  
 Canadian Patent Office; International Search Report and Written Opinion; PCT Application No. PCT/IB2014/000462, dated Jul. 16, 2014, 13 pages.  
 "Standard Guide for Characterizing Hydrocarbon Lubricant Base Oils", The American Society for Testing and Materials, ASTM D6074-08, Nov. 2008.  
 "Engine Oil Licensing and Certification Systems Specification", American Petroleum Institute, API 1509, 14th Edition, Dec. 1996.

\* cited by examiner

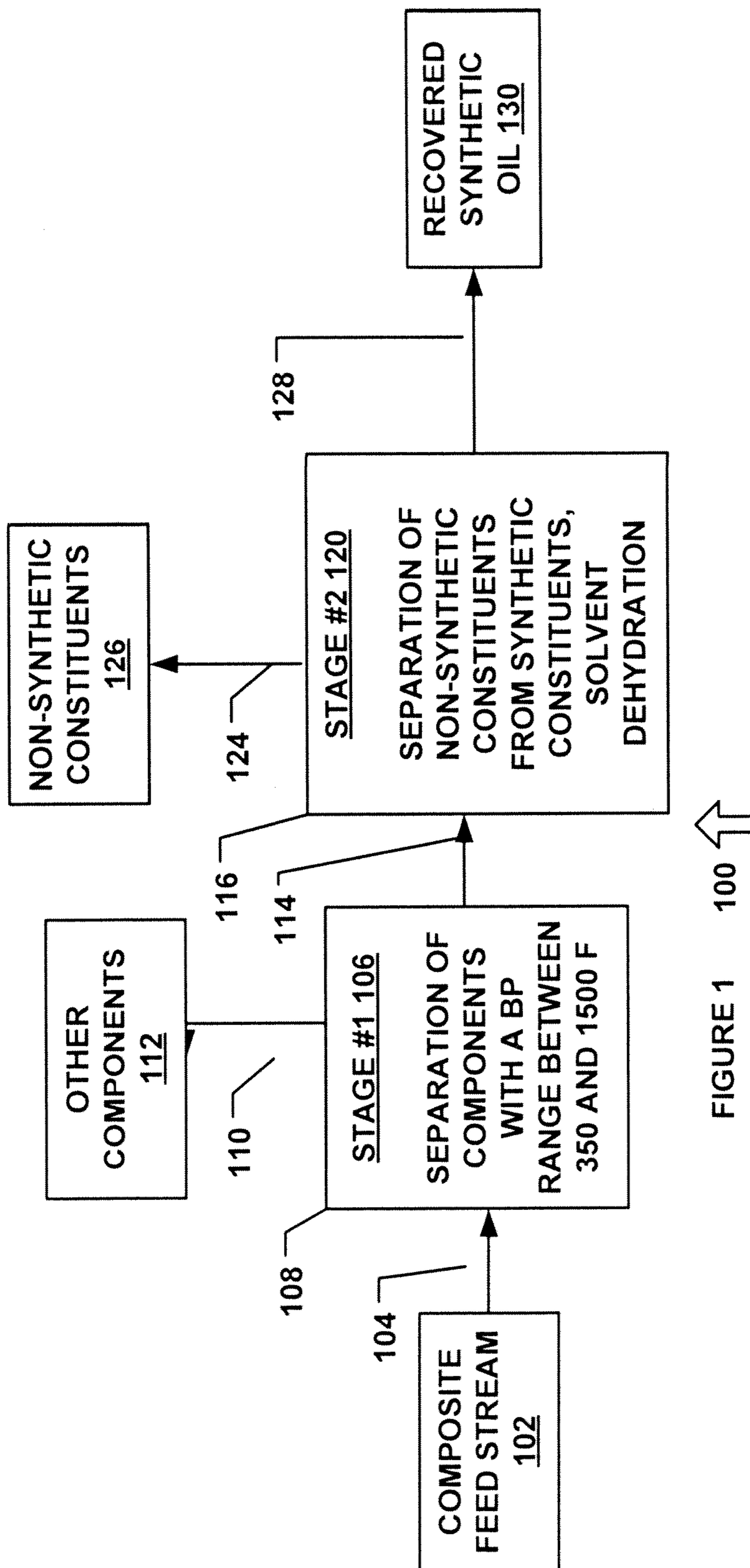

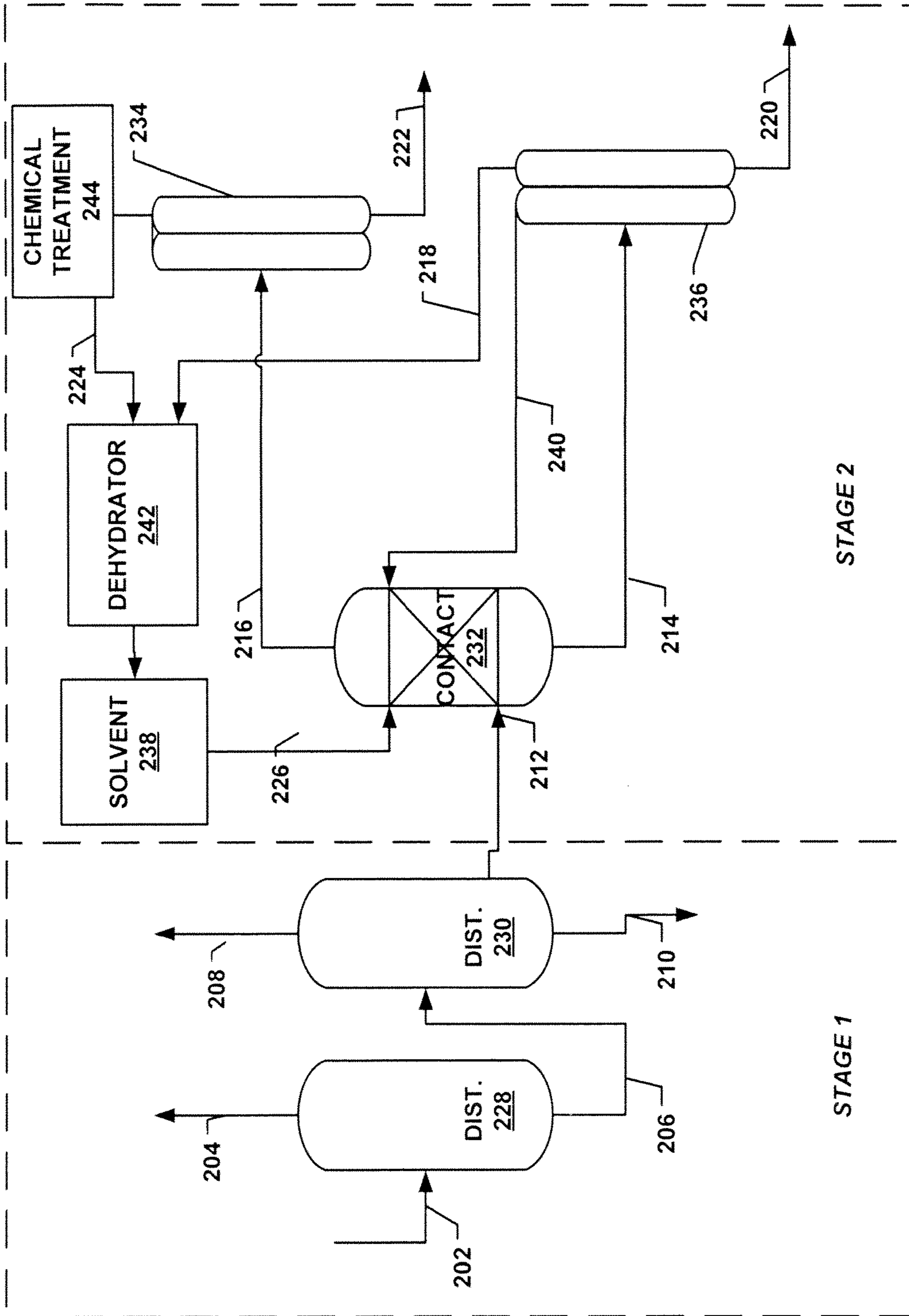
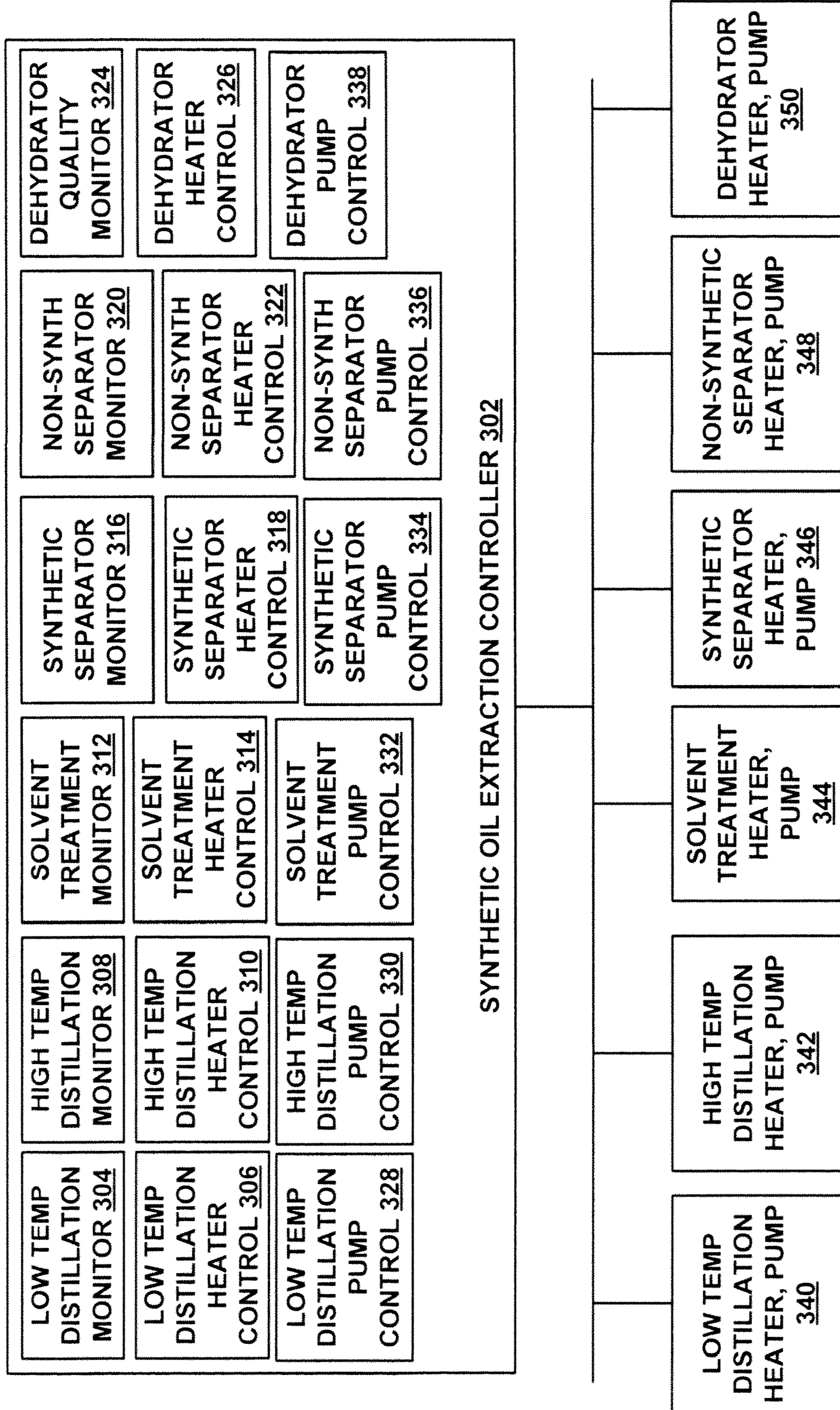

FIGURE 2 200

FIGURE 3  
300 ↙



1

## METHOD AND APPARATUS FOR RECOVERING SYNTHETIC OILS FROM COMPOSITE OIL STREAMS

### RELATED APPLICATIONS

The present application claims priority to U.S. Provisional Patent Application No. 61/774,027, filed Mar. 7, 2013 and U.S. Provisional Patent Application No. 61/774,037, filed Mar. 7, 2013, and is related to U.S. Pat. No. 8,366,912, issued Feb. 5, 2013, which are hereby incorporated by reference for all purposes as if set forth herein in their entirety.

### TECHNICAL FIELD

The present disclosure relates to the recovery of synthetic oils, and more specifically to the recovery of synthetic oils from blended, composite or contaminated streams.

### BACKGROUND OF THE INVENTION

Large volumes of synthetic oils are produced world-wide, but are typically discarded after use.

### SUMMARY OF THE INVENTION

A method for recovering synthetic oils from a feed stream is provided. The method includes separating at least a portion of the non-synthetic oil constituents from a commingled stream to produce a partially purified synthetic oil stream and one or more contaminant streams. At least a portion of the synthetic oil is separated from the partially purified synthetic oil stream to produce a synthetic oil stream and a second contaminant stream.

Other systems, methods, features, and advantages of the present disclosure will be or become apparent to one with skill in the art upon examination of the following drawings and detailed description. It is intended that all such additional systems, methods, features, and advantages be included within this description, be within the scope of the present disclosure, and be protected by the accompanying claims.

### BRIEF DESCRIPTION OF THE SEVERAL VIEWS OF THE DRAWINGS

Aspects of the disclosure can be better understood with reference to the following drawings. The components in the drawings are not necessarily to scale, emphasis instead being placed upon clearly illustrating the principles of the present disclosure. Moreover, in the drawings, like reference numerals designate corresponding parts throughout the several views, and in which:

FIG. 1 is a diagram of a system for recovering synthetic oil from a waste oil stream, in accordance with an exemplary embodiment of the present disclosure;

FIG. 2 is a diagram of system for separating synthetic oil from a waste oil stream in accordance with an exemplary embodiment of the present disclosure; and

FIG. 3 is a diagram of a controller for controlling a synthetic oil extraction process from waste oil in accordance with an exemplary embodiment of the present disclosure.

### DETAILED DESCRIPTION OF THE INVENTION

In the description that follows, like parts are marked throughout the specification and drawings with the same

2

reference numerals. The drawing figures might not be to scale and certain components can be shown in generalized or schematic form and identified by commercial designations in the interest of clarity and conciseness.

5 Synthetic oils such as polyalphaolefins have unique thermal, electrical, lubricating, and chemical stability properties that make them suitable for a number of diverse uses, such as: a heat transfer medium in chillers, heaters, transformers, and engines; a seal material in vacuum equipment and pumps; a lubricant in turbines, combustion engines, chains, and mechanical equipment; a constituent in greases and metalworking fluids; and a component of cosmetics, food stuffs and medical supplies. There are several different means of producing such synthetic oils. The type of synthetic oil is generally defined by the process or the chemical precursors used to manufacture the synthetic oil. For example, polyalphaolefins can be synthesized by the oligomerization of 1-decene or other alphaolefin monomers, which are combined to form longer chain molecules. Ester-based synthetic oils can be made from ester precursors. Other synthetic oils can be manufactured using gas to liquid technologies whereby methane molecules are combined to form longer chain molecules. Additionally, some synthetic oil molecules can be manufactured by chemical reformation of petroleum streams, such as isomerization processes. The synthetic oil produced by each of these processes is consistent in chemical structure and physical properties.

Synthetic oils, through blending, usage and/or handling, can become contaminated with oxidation and degradation products, water, fuels, solvents, chemicals, petroleum products, fine particulates and the like. Service can also result in changes in the molecular structure of some of the synthetic oil molecules, thereby changing the original nature and performance of these molecules. These contaminants or changed molecules may reduce the desired performance of the synthetic stream as a whole, potentially rendering the composite stream unsuitable for its intended use. Contaminated synthetic oil is typically removed from pipelines, equipment or storage and considered waste.

40 The present disclosure concerns the recovery of composite oil streams, contaminated oil streams, blended oil streams, waste industrial fluid streams or other oil sources that contain synthetic oil. With advancements in technology, the amount of synthetic oils produced and used in the United States and around the world has increased to the point where such use has become significant. Currently, the vast majority of the composite, contaminated, blended or waste synthetic oil is combined with industrial fuels and burned as a combustion fuel. This practice not only contributes significant pollutants to the environment, but also wastes the energy and resources that were used to generate these valuable synthetic streams from their precursors. Accordingly, the present disclosure recognizes the need to recover and reuse these synthetic streams. The disclosed synthetic oil recovery process recovers a high percentage of the available synthetic molecules in the contaminated, composite, blended or waste oil stream in an environmentally friendly, economically viable and commercially sound manner.

60 FIG. 1 is a diagram of a system 100 for recovering synthetic oil from a waste oil stream, in accordance with an exemplary embodiment of the present disclosure. A composite stream 102 consisting of at least a portion of synthetic oil line in addition to non-synthetic oil is charged to a contaminant separation zone 108, where contaminants with a molecular weight of less than 200 or greater than 15,000 or a boiling point less than around 500° F. and greater than

around 1200° F., line **110**, is separated from the components that have a molecular weight between around 200 to around 15,000 or a boiling point between around 500° F. and 1200° F., line **14**. The materials recovered through line **110** can be low molecular weight materials such as light hydrocarbons, water, glycols, and the like, typically having a boiling range generally below about 500° F. and high molecular weight materials and non-volatiles including particulates, polymers, heavy petroleum product, salts, and the like, typically having a boiling point greater than about 1200° F. A portion of the synthetic oil constituents are recovered through a line **114**. This stream typically consists of molecules with a molecular weight of around 200 to around 15,000 typically having a boiling point between about 500 to about 1200° F. In a further separation zone **116**, a portion of the synthetic oil is separated and recovered through a line **128**. Line **128** is primarily synthetic oil typically consisting of one or more of polyalphaolefins, esters and other types of synthetic oil molecules. A second stream line **124**, which is oil that is low in synthetic oil molecules, is also produced. This is a relatively generalized showing of the process of the present disclosure.

In the first stage, zone **106**, some of the physical contaminants are separated from the synthetic oil. Typically, such contaminants include water, light hydrocarbons, solvents, solids, polymers, high molecular weight hydrocarbons, chemicals, salts, non-volatiles, and the like. Several processes or combination of processes can be used to effect this separation including various forms of extraction, distillation, filtration, centrifugation, absorption and adsorption, and the like, as known to those skilled in the art. Typically, the separation will take place based upon differences in the physical or chemical properties of the synthetic oil fraction and the various contaminating materials. In the second stage, the partially purified synthetic oil stream, line **114**, is then fed to zone **116** of the process where the remaining contaminants are removed from the synthetic oil. One or more of the following processes can be used to effect separation of the synthetic oil stream **128** from the non-synthetic oil components. These processes include one or more of various forms of solvent extraction, supercritical extraction, ultrafiltration, absorption, adsorption, molecular sieves, and the like, as known to those skilled in the art. Dehydration of the solvent used in solvent extraction is performed to reduce absorbed water to a much smaller percentage of solvent than would normally be used, such as to less than 0.1 percent as compared to 1 to 2 percent. This increased dehydration improves the quality of the synthetic oil stream **128**, even though the overall process efficiency may be lower than processes that utilize solvent with more dissolved water. The synthetic oil stream can be sold as a product to be used wherever synthetic oils are typically used or may be further treated to separate the synthetic oil into two or more synthetic oil fractions differing in one or more of molecular weight, morphology, chemical composition or physical properties.

FIG. **2** is a diagram of system **200** for separating synthetic oil from waste oil stream in accordance with exemplary embodiment of the present disclosure. In Stage **1**, a distillation system **228** is shown for separating materials that have a boiling point less than 500° C., line **204**, from the composite stream, line **202**, thereby producing a partially purified synthetic and non-synthetic oil stream. The distillation system **228** consists of one or more vessels which may be operated under vacuum or at pressure and can be single or multiple staged as known to those skilled in the art. Stream **204** generally consists of one or more contaminants

that have a low boiling point, such as water, light hydrocarbons, glycols, solvents, and other volatile materials such as might be found to have been combined with the synthetic molecules. The low boiling point contaminants also contain breakdown products from the synthetic oil. In certain rigorous applications, it is possible for the synthetic molecules to split into two or more smaller molecules. One or more of these may be volatile below 50° F. and would end up in stream **204**. In the instances where the synthetic oil has not split or contaminated with volatile materials, the flow of stream **204** can be minimal or zero.

The composite stream line **206** consists of the material that generally has a boiling point greater than 500° F. This stream discharges from the bottom of distillation system **228** and is optionally heated and charged into a second distillation system **230**. The second distillation system **230** consists of one or more distillation devices such as columns, evaporators, or the like, known to those skilled in the art for fractionating streams based on boil point. The distillation devices can be operated under vacuum and/or at pressure and can be single or multiple staged as known to those skilled in the art. In distillation system **230**, at least a portion of the molecules having a boiling point between 500° F. and 1,200° F. are separated from the balance the composite stream. The compounds having a boiling point less than 500° F. pass from the distillation devices whereon they are condensed and collected. The compounds with a boiling point generally greater than 1200° F. are separated from the compounds with a boiling point between 500° F. and 1200° F. by distillation or in other suitable manners and exit the second distillation system through line **210**. The compounds that have a boiling point generally between 500° F. and 1200° F., or partially purified synthetic oil, exit the second distillation system through line **212** and are passed to the second stage of the process.

The second stage of the process consists of solvent extraction and recovery. The stream in line **212** is generally passed through a cooler to a solvent treating vessel **232**. This solvent treating vessel is shown with a top and a bottom. A contact section is shown schematically in the center portion of the vessel. A solvent storage vessel is shown at **238** and supplies solvent to an upper portion of vessel **232** near its top via a line **226**. The solvent moves downwardly, counter-current to the partially purified synthetic oil stream via a line **212**, which is introduced near the bottom of contact section. Upon contact, the solvent does not react with the synthetic molecules, however, it does react with the non-synthetic molecules cleaving to them and causing them to be extracted from the synthetic molecules.

The synthetic oil molecules are recovered with a portion of the solvent from the top of vessel **232** and passed via a line **216** to first solvent separation vessels **234**, which each have a top and a bottom, where the solvent is separated from the synthetic oil molecules and the synthetic oil is passed via a line **222** to product storage. The use of multiple vessels increases the efficiency of the synthetic oil separation process. Contact vessel **232** can have multiple injection points in the vessel associated columns, to control the solvent concentration in the vessel or associated columns. Line **222** thus contains purified synthetic oil stream which can be used in a number of applications wherein synthetic oils are used. Contact vessel **232** can be operated at a temperature range that is close to the stability limit at which the solvent and oil become completely miscible. In one exemplary embodiment, the temperature range can be controlled to that there are points within contact vessel **232** where the temperature stability limit is exceeded, and the solvent and oil become

completely miscible, but where the temperature at other points is below the stability limit.

The solvent is recovered through a line **224**, and is typically treated to remove water, low boiling point contaminants, and the like through dehydrator **242** and returned to solvent storage **238**. The amount of water removed from the solvent is not limited, as is common in known processes, where the water content is used to improve the quality of non-synthetic oil. However, with the increasing use of synthetic oil, waste oil typically contains a greater amount of synthetic oil that is of greater value than the non-synthetic oil. As such, even though removal of as much water from the solvent as possible results in a decrease in the efficiency of the process (due to increasing energy and processing requirements for the dehydration process), and also results in less efficient processing of non-synthetic oil, the use of solvent with small amounts of dissolved water results in an improved quality of synthetic oil extraction.

The solvent recovery process can result in the buildup of organic acids as the solvent is reused. These organic acids can corrode the parts or system **200**, and can be removed with chemical treatment system **244**, which can process the solvent with caustic materials to neutralize the organic acids.

A bottom stream **214** is recovered from vessel **232** and passed to a second solvent separation vessels **236**, each of which have a top and a bottom. In vessels **236**, the solvent is stripped from the extracted primarily non-synthetic contaminant and passed via a line **218** back to solvent storage **238**. The non-synthetic contaminants recovered from the bottom of vessel **236** are passed via a line **220** storage. In addition, a line **240** from one or more of the first of the second solvent separation vessels **236** is provided back to vessel **232**. This line is relatively rich in solvent, even though it contains some extracted non-synthetic oil compounds and other compounds, and can be provided to vessel **232** to improve the overall process efficiency by reducing the amount of solvent that is processed through dehydrator **242**.

In the embodiment described in Stage **1** above, two distillation systems are used to separate a portion of the contaminants from the synthetic oil fraction. In accordance with the present disclosure, it may be desirable to use as few as one or as many as five distillation systems, each consisting of one or more vessels to effect this separation.

In the embodiment described above, prior to the first vessel of Stage **1**, an optional treatment vessel can be used to chemically treat the composite stream prior to entry into distillation system **224** to facilitate treatment. This chemical treatment can be an alkali or base material such as sodium carbonate, sodium bicarbonate, sodium hydroxide, potassium hydroxide, or an acid such as sulfuric acid, or other chemicals known to reduce the amount of the composite stream components that cause to enhance separation and processing, to increase equipment availability and to enhance the quality of the synthetic oil or other products.

In Stage **1** of the embodiment described above, vessels are used to separate various constituents from the synthetic oil fraction. These vessels can include simple evaporators, thin or wiped film evaporators, columns, packed columns, vessels, tanks, pipes or any suitable vessel or system that effects single or multi-stages of separation. These vessels may be operated under vacuum or pressure.

In the practice of the present invention, it may be desirable in some instances for the boiling point of stream **212** to be between about 650 and 1200° F. The boiling point range of the material recovered through line **212** can be modified if desired to produce a synthetic oil product having a slightly higher initial boiling point or the like. Additionally, if

desired, a distillation column can be used to fractionate the synthetic oil stream **222** into different fractions.

In some instances, it may be preferable to create more than one partially purified synthetic oil stream from distillation column **230**, differing in terms of distillation profile. In this instance, one or more storage vessels can be used between Stage **1** and Stage **2** and the material passed to Stage **2** on a blocked out basis. Thus Stage **2** would be used to purify each of the streams individually. While one first partially purified synthetic oil stream is being processed through Stage **2**, the other stream(s) are accumulated in intermediate storage tanks. When the first stream tank is close to being emptied, Stage **2** can then be used to process the content of a second intermediate storage tank containing a second partially purified synthetic oil stream.

In the embodiment described above, Stage **2** is used separate the similar molecular weight contaminants from the synthetic oil molecules. In certain instances, it may also be possible to further upgrade the contaminant stream through further processing such as filtration, chemical treatment, or extraction using a different solvent, hydrogenation or other suitable processes.

In the embodiment shown above, the solvent recovered from the synthetic oil stream **216** and the contaminant stream **214** are consolidated in a solvent storage vessel **238**. Either prior to vessel **234** or post vessel **238**, the solvent can be treated to remove any contaminants such as water or similar boiling point materials that may have contaminated the solvent. Such treatments include distillation, extraction, absorption, adsorption, osmosis, chemical treatment or other suitable treatments.

In Stage **1** of the embodiment shown above, distillation system **228** typically consists of one or more distillation vessels, which are operated under vacuum ranging from full vacuum to 500 mmHg and preferably between 2 and 30 mmHg and at a temperature generally between about 500 and about 750° F.

In the second stage of the embodiment shown above, the extraction process used in vessel **232** can include solvent extraction, with materials such as ethanol, diacetone-alcohol, ethylene-glycol-mono(low alkyl) ether, di-ethylene-glycol, diethylene-glycolmono(low alkyl) ether, o-chlorophenol furfural, acetone, formic acid, 4-butyrolactone, low-alkyl-ester of low mono- and dicarbonic acids, dimethylformamide, 2-pyrrolidone and N-(low alkyl)2-pyrrolidone, N-methyl-2-pyrrolidone, epi-chlorohydrin, dioxane, morpholine, low-alkyl and amino(low-alkyl)morpholine, benzonitrile and di-(low-alkyl)sulfoxide and phosphonate, or other suitable separation processes.

N-methyl-2-pyrrolidone can also be used as a solvent for the process of the present disclosure. In this embodiment, extraction is undertaken at a temperature between about 100° F. and about 250° F. and preferably between about 130° F. and about 190° F. Typically, both the solvent and partially purified synthetic oil are fed into the extraction column within this temperature range, although not necessarily at the same temperature. The solvent dosage (percent of solvent relative to feed) fed to the extraction column is typically between 50% and 1000% by volume and preferably between 100% and 400%. Typically, extraction is undertaken in a packed or trayed column whereby the solvent is fed into the top of the column and partially purified synthetic oil is fed into the bottom. The packed column can contain structured packing, random packing or other suitable packing. Water may be injected into the solvent or extraction column as desired to control solvent selectivity. Similarly, temperature gradients or regional heating or cooling can be used at

various points along or across the extraction column to affect performance and selectivity. Recycles of both raffinate and extract at similar or different temperatures can also be employed. In some instances, it may be beneficial to remove a side stream from the extraction column, raffinate or extract streams cool, and separate a portion of the solvent from the oil and return the oil to the column. The solvent may be recovered from the raffinate stream in line and the extract stream in line using distillation. The distillation can be undertaken atmospherically or by using vacuum. Flash separators or multi-stage columns can be used or combinations thereof can be used in order to separate the solvent from the synthetic oil or the extracted contaminants.

In the exemplary embodiment described above, additional processing may be undertaken on the distillate stream from vessel 228 such as further separating the constituents of this stream (water, glycols, solvents, light hydrocarbons), thereby creating separate products which may be used or further upgraded to higher quality products. In the disclosed embodiment, only one distillate cut taken from vessel 228.

It may also be suitable in some instances to use a phase transfer catalyst or the like to enhance the operation of the second stage of the process whereby the efficiency, selectivity, and other attributes of the process are enhanced, thereby providing for better separation of the high quality base oil molecules from the lower quality molecules.

By the process of the present disclosure, the synthetic oil stream is separated from a composite stream wherein the synthetic oil is contaminated with other non-synthetic oil materials. The combination of these steps results in a process that is able to recover synthetic oils which heretofore have not been recovered. The recovered synthetic oil is available for reuse in many of its originally intended fields of service. Hence the present disclosure has the benefits of recovering a valuable product stream and reducing demand for the synthesis of virgin streams from their precursors.

FIG. 3 is a diagram of a controller 300 for controlling a synthetic oil extraction process from waste oil in accordance with an exemplary embodiment of the present disclosure. Controller 300 can be implemented in hardware or a suitable combination of hardware and software, and can include one or more software systems operating on a processor.

As used herein, "hardware" can include a combination of discrete components, an integrated circuit, an application-specific integrated circuit, a field programmable gate array, or other suitable hardware. As used herein, "software" can include one or more objects, agents, threads, lines of code, subroutines, separate software applications, two or more lines of code or other suitable software structures operating in two or more software applications, on one or more processors where a processor includes a microcomputer or other suitable controller, memory devices, input-output devices, displays, data input devices such as keyboards or mice, peripherals such as printers and speakers, associated drivers, control cards, power sources, network devices, docking station devices, or other suitable devices operating under control of software systems in conjunction with the processor or other devices), or other suitable software structures. In one exemplary embodiment, software can include one or more lines of code or other suitable software structures operating in a general purpose software application, such as an operating system, and one or more lines of code or other suitable software structures operating in a specific purpose software application. As used herein, the term "couple" and its cognate terms, such as "couples" and "coupled," can include a physical connection (such as a copper conductor), a virtual connection (such as through

randomly assigned memory locations of a data memory device), a logical connection (such as through logical gates of a semiconducting device), other suitable connections, or a suitable combination of such connections.

System 300 includes synthetic oil extraction controller 302, which includes low temperature distillation monitor 304, high temperature distillation monitor 308, solvent treatment monitor 312, synthetic separator monitor 316, non-synthetic separator monitor 320, dehydrator quality monitor 324, low temperature distillation heater controller 306, high temperature distillation heater controller 310, solvent treatment heater controller 314, synthetic separator heater controller 318, non-synthetic separator heater controller 322, dehydrator heater controller 326, low temperature distillation pump controller 328, high temperature distillation pump controller 330, solvent treatment pump controller 332, synthetic separator pump controller 334, non-synthetic separator pump controller 336 and dehydrator pump controller 338, each of which can be implemented as one or more objects having associated graphical and functional characteristics. Consolidation these monitors and controls in a single location, display panel or set of display panels allows process variables to be readily monitored and coordinated, unlike separate systems in different locations that have to be monitored and adjusted over time. Such separate systems can have process variations that are not observed by a single operator, which can result in lower quality, lower efficiency or other problems. These problems are more pronounced and significant when processing waste oil with high amounts of synthetic oil compounds, because the quality of the waste oil and the composite compounds of the waste oil can be highly variable, which can make it difficult to adjust process variables over time.

Low temperature distillation monitor 304 generates one or more low temperature distillation metrics, such as temperature, pump speed, pressure, flow rate or other suitable metrics. In one exemplary embodiment, low temperature distillation monitor 304 can include one or more user-selectable controls that allow a user to display or hide a metric, to increase the size of a display for a metric, to add an audible alarm for a metric, or other suitable functions.

High temperature distillation monitor 308 generates one or more high temperature distillation metrics, such as temperature, pump speed, pressure, flow rate or other suitable metrics. In one exemplary embodiment, high temperature distillation monitor 308 can include one or more user-selectable controls that allow a user to display or hide a metric, to increase the size of a display for a metric, to add an audible alarm for a metric, or other suitable functions.

Solvent treatment monitor 312 generates one or more solvent metrics, such as pump speed, pressure, flow rate or other suitable metrics. In one exemplary embodiment, solvent treatment monitor 312 can include one or more user-selectable controls that allow a user to display or hide a metric, to increase the size of a display for a metric, to add an audible alarm for a metric, or other suitable functions.

Synthetic separator monitor 316 generates one or more synthetic separator metrics, such as temperature, pump speed, pressure, flow rate or other suitable metrics. In one exemplary embodiment, synthetic separator monitor 316 can include one or more user-selectable controls that allow a user to display or hide a metric, to increase the size of a display for a metric, to add an audible alarm for a metric, or other suitable functions.

Non-synthetic separator monitor 320 generates one or more non-synthetic separator metrics, such as temperature, pump speed, pressure, flow rate or other suitable metrics. In

one exemplary embodiment, non-synthetic separator monitor **320** can include one or more user-selectable controls that allow a user to display or hide a metric, to increase the size of a display for a metric, to add an audible alarm for a metric, or other suitable functions.

Dehydrator quality monitor **324** generates one or more evaporator quality metrics, such as temperature, pump speed, pressure, flow rate or other suitable metrics. In one exemplary embodiment, dehydrator quality monitor **324** can include one or more user-selectable controls that allow a user to display or hide a metric, to increase the size of a display for a metric, to add an audible alarm for a metric, or other suitable functions.

Low temperature distillation heater controller **306** generates one or more user-selectable controls for low temperature distillation heater and pump **340**, such as an increase temperature control, a decrease temperature control or other suitable controls. In one exemplary embodiment, low temperature distillation heater controller **306** can interface with low temperature distillation monitor **304** to perform a suitable function in response to an alarm or setting, such as to increase a temperature in response to a low temperature alarm or setting, to decrease a temperature in response to a high temperature alarm or setting, or to perform suitable functions.

High temperature distillation heater controller **310** generates one or more user-selectable controls for high temperature distillation heater and pump **342**, such as an increase temperature control, a decrease temperature control or other suitable controls. In one exemplary embodiment, high temperature distillation heater controller **310** can interface with high temperature distillation monitor **308** to perform a suitable function in response to an alarm or setting, such as to increase a temperature in response to a low temperature alarm or setting, to decrease a temperature in response to a high temperature alarm or setting, or to perform other suitable functions.

Solvent treatment heater controller **314** generates one or more user-selectable controls for solvent treatment valve and pump **344**, such as an increase temperature control, a decrease temperature control or other suitable controls. In one exemplary embodiment, solvent treatment heater controller **314** can interface with solvent treatment monitor **312** to perform a suitable function in response to an alarm or setting, such as to increase a temperature in response to a low temperature alarm or setting, to decrease temperature response to a high temperature alarm or setting, or to perform other suitable functions.

Synthetic separator heater controller **318** generates one or more user-selectable controls for synthetic separator heater and pump **346**, such as an increase temperature control, a decrease temperature control or other suitable controls. In one exemplary embodiment, synthetic separator heater controller **318** can interface with synthetic separator monitor **316** to perform a suitable function in response to an alarm or setting, such as to increase a temperature in response to a low temperature alarm or setting, decrease a temperature in response to a high temperature alarm or setting, or to perform other suitable functions.

Non-synthetic separator heater controller **322** generates one or more user-selectable controls for non-synthetic separator heater and pump **348**, such as an increase temperature control, a decrease temperature control or other suitable controls. In one exemplary embodiment, non-synthetic separator heater controller **322** can interface with non-synthetic separator monitor **320** to perform a suitable function in response to an alarm or setting, such as to increase a

temperature in response to a low temperature alarm or setting, to decrease a temperature in response to a high temperature alarm or setting, or to perform other suitable functions.

Dehydrator heater controller **326** generates one or more user-selectable controls for dehydrator heater and pump **350**, such as an increase temperature control, a decrease temperature control or other suitable controls. In one exemplary embodiment, dehydrator heater controller **326** can interface with dehydrator quality monitor **324** to perform a suitable function in response to an alarm or setting, such as to increase a temperature in response to a low temperature alarm or setting, to decrease a temperature in response to a high temperature alarm or setting, or to perform other suitable functions.

Low temperature distillation pump controller **328** generates one or more user-selectable controls for low temperature distillation heater and pump **340**, such as an increase pump speed control, a decrease pump speed control or other suitable controls. In one exemplary embodiment, low temperature distillation pump controller **328** can interface with low temperature distillation monitor **304** to perform a suitable function in response to an alarm or setting, such as to increase a pump speed and change associated valve settings in response to a low pressure alarm or setting, to decrease a pump speed and change associated valve settings in response to a high pressure alarm or setting, or to perform other suitable functions.

High temperature distillation pump controller **330** generates one or more user-selectable controls for high temperature distillation heater and pump **342**, such as an increase pump speed control, a decrease pump speed control or other suitable controls. In one exemplary embodiment, high temperature distillation pump controller **330** can interface with high temperature distillation monitor **308** to perform a suitable function in response to an alarm or setting, such as to increase a pump speed and change associated valve settings in response to a low pressure alarm or setting, to decrease a pump speed and change associated valve settings in response to a high pressure alarm or setting, or to perform other suitable functions.

Solvent treatment pump controller **332** generates one or more user-selectable controls for solvent treatment heater and pump **344**, such as an increase pump speed control, a decrease pump speed control or other suitable controls. In one exemplary embodiment, solvent treatment pump controller **332** can interface with solvent treatment monitor **312** to perform a suitable function in response to an alarm or setting, such as to increase a pump speed and change associated valve settings in response to a low pressure alarm or setting, to decrease a pump speed and change associated valve settings in response to a high pressure alarm or setting, or to perform other suitable functions.

Synthetic separator pump controller **334** generates one or more user-selectable controls for synthetic separator heater and pump **346**, such as an increase pump speed control, a decrease pump speed control or other suitable controls. In one exemplary embodiment, synthetic separator pump controller **334** can interface with synthetic separator monitor **316** to perform a suitable function in response to an alarm or setting, such as to increase a pump speed and change associated valve settings in response to a low pressure alarm or setting, to decrease a pump speed and change associated valve settings in response to a high pressure alarm or setting, or to perform other suitable functions.

Non-synthetic separator pump controller **336** generates one or more user-selectable controls for non-synthetic separator

## 11

rator heater and pump **348**, such as an increase pump speed control, a decrease pump speed control or other suitable controls. In one exemplary embodiment, non-synthetic separator pump controller **336** can interface with non-synthetic separator monitor **320** to perform a suitable function in response to an alarm or setting, such as to increase a pump speed and change associated valve settings in response to a low pressure alarm or setting, to decrease a pump speed and change associated valve settings in response to a high pressure alarm or setting, or to perform other suitable functions.

Dehydrator pump controller **338** generates one or more user-selectable controls r dehydrator heater and pump **350**, such as an increase pump speed control, a decrease pump speed control or other suitable controls. In one exemplary embodiment, dehydrator pump controller **338** can interface with dehydrator quality monitor **324** to perform a suitable function in response to an alarm or setting, such as to increase a pump speed and change associated valve settings in response to a low pressure alarm or setting, to decrease a pump speed and change associated valve settings in response to a high pressure alarm or setting, or to perform other suitable functions.

Low temperature distillation heater and pump **340** can include one or more heaters, pumps, valves, chillers, compressors and other associated components of a low temperature distillation apparatus such as distillation **228**. Although exemplary systems for heater and pump control are described herein, additional systems for individual or group control of valves, chillers, compressors or other components can also or alternatively be provided.

High temperature distillation heater and pump **342** can include one or more heaters, pumps, valves, chillers, compressors and other associated components of a high temperature distillation apparatus such as distillation **230**. Although exemplary systems for heater and pump control are described herein, additional systems for individual or group control of valves, chillers, compressors or other components can also or alternatively be provided.

Solvent treatment heater and pump **344** can include one or more heaters, pumps, valves, chillers, compressors and other associated components of a solvent treatment apparatus such as **232**. Although exemplary systems for heater and pump control are described herein, additional systems for individual or group control of valves, chillers, compressors or other components can also or alternatively be provided.

Synthetic separator heater and pump **346** can include one or more heaters, pumps, valves, chillers, compressors and other associated components of a synthetic separator apparatus such as separator **234**. Although exemplary systems for heater and pump control are described herein, additional systems for individual or group control of valves, chillers, compressors or other components can also or alternatively be provided.

Non-synthetic separator heater and pump **348** can include one or more heaters, pumps, valves, chillers, compressors and other associated components of a non-synthetic separator apparatus such as separator **236**. Although exemplary systems for heater and pump control are described herein, additional systems for individual or group control of valves, chillers, compressors or other components can also or alternatively be provided.

Dehydrator heater and pump **350** can include one or more heaters, pumps, valves, chillers, compressors and other associated components of a dehydrator apparatus such as dehydrator **242**. Although exemplary systems for heater and pump control are described herein, additional systems for

## 12

individual or group control of valves, chillers, compressors or other components can also or alternatively be provided.

It should be emphasized that the above-described embodiments are merely examples of possible implementations. Many variations and modifications may be made to the above-described embodiments without departing from the principles of the present disclosure. All such modifications and variations are intended to be included herein within the scope of this disclosure and protected by the following claims.

What is claimed is:

**1.** A method for recovering synthetic oils from a feed stream, the method comprising:

separating at least a portion of the non-synthetic oil constituents from a commingled stream producing a partially purified synthetic oil stream and one or more contaminant streams; and

separating at least a portion of the synthetic oil from the partially purified synthetic oil stream by solvent extraction with solvent having less than 0.1 percent absorbed water to produce a synthetic oil stream and a second contaminant stream.

**2.** The method according to claim **1**, wherein the partially purified synthetic oil stream has a molecular weight between 200 and 15,000.

**3.** The method of claim **1**, wherein the partially purified synthetic oil stream has a boiling point in the same range as the synthetic oil stream that is being recovered.

**4.** The method according to claim **1**, whereby the partially purified synthetic oil stream is separated from the contaminant stream by at least one of distillation, vacuum distillation, evaporation, filtration, ultrafiltration, solvent extraction, extraction, centrifugation, absorption, and adsorption.

**5.** The method of claim **1**, wherein the partially purified synthetic oil stream is separated from the comingled stream by distillation.

**6.** The method of claim **1**, wherein the non-synthetic oil constituents are at least partially separated from the comingled stream by a combination of one or more of atmospheric and vacuum distillation.

**7.** The method of claim **3**, wherein the synthetic oil stream has a boiling point between about 500 to about 1200° F.

**8.** The method of claim **1**, wherein the synthetic oil stream is separated from the partially purified synthetic oil stream by solvent extraction with solvent recovery and dehydration processing.

**9.** The method of claim **1**, wherein the solvent used to perform the solvent extraction is one or more of ethanol, diacetone-alcohol, ethylene-glycol-mono(low alkyl) ether, di-ethylene-glycol, diethylene-glycolmono(low alkyl) ether, o-chlorophenol furfural, acetone, formic acid, 4-butyrolactone, low-alkyl-ester of low mono- and dicarbonic acids, dimethylformamide, 2-pyrrolidone and N-(low alkyl)2-pyrrolidone, N-methyl-2-pyrrolidone, epi-chlorohydrin, dioxane, morpholine, low-alkyl- and amino(low-alkyl)morpholine, benzonitrile and di-(low-alkyl) sulfoxide and phosphonate.

**10.** The method of claim **9**, wherein the solvent is N-methyl-2-pyrrolidone.

**11.** The method of claim **1**, wherein the synthetic oil stream consists of oils that were made through one or more of chemical synthesis, gas to liquid technologies, hydrosomerization or chemical modification of petroleum compounds.

**12.** The method according to claim **1**, wherein the synthetic oils consist primarily of hydrogen and carbon having a molecular weight between 200 and 15,000.

**13**

**13.** The method according to claim 1, wherein the synthetic oil stream consists of one or more of polyalphaolefins, esters, diesters, polyolesters, alkylated naphthalenes, alkylated benzenes, neopoly esters, and paraffins.

**14.** The method according to claim 1, wherein the second contaminant stream consists of one or more of compounds considered to be polars, aromatics, unsaturates or olefins.

**15.** The method of claim 1, further comprising a plurality of monitors and controls configured to allow an operator to continuously monitor operating pressures and temperatures to adjust one or more heater controls and one or more pump controls in response to variations in waste oil components of the feed stream.

**16.** A method for recovering synthetic oils from a feed stream, the method comprising:

- a) separating at least a portion of the non-synthetic oil constituents from a commingled stream producing a partially purified synthetic oil stream and one or more contaminant streams;

**14**

b) separating at least a portion of the synthetic oil from the partially purified synthetic oil stream by solvent extraction with solvent having less than 0.1 percent absorbed water to produce a synthetic oil stream and a second contaminant stream;

c) separating a first solvent stream from the synthetic oil stream and/or separating a second solvent stream from the second contaminant stream;

d) subjecting the first separated solvent stream and/or a portion of the second separated solvent stream to dehydration processing to reduce amount of absorbed water to less than 0.1%; and

e) recycling at least a portion of the dehydrated solvent stream to the solvent extraction in step b).

**17.** The method of claim 1, further comprising recycling a portion of the separated second solvent stream without dehydration to the solvent extraction in step b).

\* \* \* \* \*