

(19) World Intellectual Property Organization  
International Bureau



(43) International Publication Date  
31 March 2005 (31.03.2005)

PCT

(10) International Publication Number  
WO 2005/029131 A2

(51) International Patent Classification<sup>7</sup>: G01V

CO, CR, CU, CZ, DE, DK, DM, DZ, EC, EE, EG, ES, FI, GB, GD, GE, GH, GM, HR, HU, ID, IL, IN, IS, JP, KE, KG, KP, KR, KZ, LC, LK, LR, LS, LT, LU, LV, MA, MD, MG, MK, MN, MW, MX, MZ, NA, NI, NO, NZ, OM, PG, PH, PL, PT, RO, RU, SC, SD, SE, SG, SK, SL, SY, TJ, TM, TN, TR, TT, TZ, UA, UG, US, UZ, VC, VN, YU, ZA, ZM, ZW.

(21) International Application Number:  
PCT/US2004/030721

(22) International Filing Date:  
17 September 2004 (17.09.2004)

(25) Filing Language: English

(26) Publication Language: English

(30) Priority Data:  
10/664,566 17 September 2003 (17.09.2003) US

(84) Designated States (unless otherwise indicated, for every kind of regional protection available): ARIPO (BW, GH, GM, KE, LS, MW, MZ, NA, SD, SL, SZ, TZ, UG, ZM, ZW), Eurasian (AM, AZ, BY, KG, KZ, MD, RU, TJ, TM), European (AT, BE, BG, CH, CY, CZ, DE, DK, EE, ES, FI, FR, GB, GR, HU, IE, IT, LU, MC, NL, PL, PT, RO, SE, SI, SK, TR), OAPI (BF, BJ, CF, CG, CI, CM, GA, GN, GQ, GW, ML, MR, NE, SN, TD, TG).

(71) Applicant (for all designated States except US): IN-PUT/OUTPUT, INC. [US/US]; 12300 Parc Crest Drive, Stafford, TX 77477 (US).

Declarations under Rule 4.17:

— as to applicant's entitlement to apply for and be granted a patent (Rule 4.17(ii)) for the following designations AE, AG, AL, AM, AT, AU, AZ, BA, BB, BG, BR, BW, BY, BZ, CA, CH, CN, CO, CR, CU, CZ, DE, DK, DM, DZ, EC, EE, EG, ES, FI, GB, GD, GE, GH, GM, HR, HU, ID, IL, IN, IS, JP, KE, KG, KP, KR, KZ, LC, LK, LR, LS, LT, LU, LV, MA, MD, MG, MK, MN, MW, MX, MZ, NA, NI, NO, NZ, OM, PG, PH, PL, PT, RO, RU, SC, SD, SE, SG, SK, SL, SY, TJ, TM, TN, TR, TT, TZ, UA, UG, UZ, VC, VN, YU, ZA, ZM, ZW, ARIPO patent (BW, GH, GM, KE, LS, MW, MZ, NA, SD, SL, SZ, TZ, UG, ZM, ZW), Eurasian patent (AM, AZ, BY, KG, KZ, MD, RU, TJ, TM), European patent (AT, BE, BG, CH, CY, CZ, DE, DK, EE, ES, FI, FR, GB, GR, HU, IE,

[Continued on next page]

(72) Inventor; and

(75) Inventor/Applicant (for US only): ISELI, James, W. [US/US]; 901 Princeton, Allen, TX 75002 (US).

(74) Agent: BYNUM, Todd, A.; Madan, Mossman & Sriram, P.C., 2603 Augusta, Suite 700, Houston, TX 77057 (US).

(81) Designated States (unless otherwise indicated, for every kind of national protection available): AE, AG, AL, AM, AT, AU, AZ, BA, BB, BG, BR, BW, BY, BZ, CA, CH, CN,

(54) Title: SINGLE STATION WIRELESS SEISMIC DATA ACQUISITION METHOD AND APPARATUS

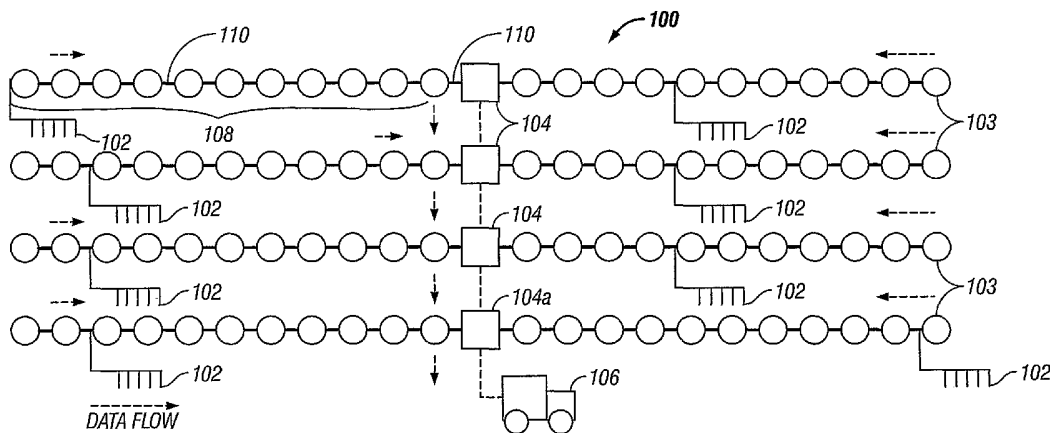

(57) Abstract: A seismic data acquisition apparatus having a recorder co-located with a sensor unit in a seismic spread and a communication device for direct communication with a central recorder. A memory located in the recorder and/or in the central controller holds location parameters associated with the sensor unit, and the parameters can be updated. Method of seismic data acquisition including sensing seismic energy and recording the sensed energy at the sensor location. Delivering the recorded information to a central recorder by manually retrieving removable memory from each recorder, by wireless transmission of the information, or by removing the information from each recorder by inductive or cable connectors and a transfer device.

WO 2005/029131 A2



*IT, LU, MC, NL, PL, PT, RO, SE, SI, SK, TR*), OAPI patent (*BF, BJ, CF, CG, CI, CM, GA, GN, GQ, GW, ML, MR, NE, SN, TD, TG*)

- as to the applicant's entitlement to claim the priority of the earlier application (Rule 4.17(iii)) for the following designations *AE, AG, AL, AM, AT, AU, AZ, BA, BB, BG, BR, BW, BY, BZ, CA, CH, CN, CO, CR, CU, CZ, DE, DK, DM, DZ, EC, EE, EG, ES, FI, GB, GD, GE, GH, GM, HR, HU, ID, IL, IN, IS, JP, KE, KG, KP, KR, KZ, LC, LK, LR, LS, LT, LU, LV, MA, MD, MG, MK, MN, MW, MX, MZ, NA, NI, NO, NZ, OM, PG, PH, PL, PT, RO, RU, SC, SD, SE, SG, SK, SL, SY, TJ, TM, TN, TR, TT, TZ, UA, UG, UZ, VC, VN, YU, ZA, ZM, ZW*, ARIPO patent (*BW, GH, GM, KE, LS, MW, MZ, NA, SD, SL, SZ, TZ, UG, ZM, ZW*), Eurasian patent (*AM, AZ,*

*BY, KG, KZ, MD, RU, TJ, TM*), European patent (*AT, BE, BG, CH, CY, CZ, DE, DK, EE, ES, FI, FR, GB, GR, HU, IE, IT, LU, MC, NL, PL, PT, RO, SE, SI, SK, TR*), OAPI patent (*BF, BJ, CF, CG, CI, CM, GA, GN, GQ, GW, ML, MR, NE, SN, TD, TG*)

**Published:**

- without international search report and to be republished upon receipt of that report

For two-letter codes and other abbreviations, refer to the "Guidance Notes on Codes and Abbreviations" appearing at the beginning of each regular issue of the PCT Gazette.

**APPLICATION FOR LETTERS PATENT**

**Title: SINGLE STATION WIRELESS SEISMIC DATA ACQUISITION  
METHOD AND APPARATUS**

**Inventor: JAMES W. ISELI**

**Background of the Invention**

5 [0001] Oil companies' conduct seismic surveying to lower risk and to reduce costs of locating and developing new oil and gas reserves. Seismic surveying is, therefore, an up front cost with intangible return value. Consequently minimizing the cost of seismic surveying and getting quality results in minimum time are important aspects of the seismic surveying process.

10 [0002] Seismic surveys are conducted by deploying a large array of seismic sensors over a surface portion of the earth. Typically, these arrays cover 50 square miles and may include 2000 to 5000 seismic sensors. An energy source (buried dynamite for example) is discharged within the array and the resulting shock wave is an acoustic wave that propagates through the subsurface structures of the earth. A portion of the wave is reflected at  
15 underground discontinuities, such as oil and gas reservoirs. These reflections are then sensed at the surface by the sensor array and recorded. Such sensing and recording are referred to herein as seismic data acquisition, which might also be performed in a passive mode without an active seismic energy source.

20 [0003] A three dimensional map, or seismic image, of the subsurface structures is generated by moving the energy source to different locations while collecting data within the array. This map is then used to make decisions about drilling locations, reservoir size and pay zone depth.

25 [0004] A very important factor in determining the quality and resolution of the

seismic image is the density of sensors in the array. Those skilled in the art recognize that greater sensor density, i.e., number of sensors in the array, provides sharper and clearer images.

5 [0005] The density of sensors is usually limited by economic and reliability factors. If the cost can be lowered and reliability increased, higher quality seismic images can be acquired. Better image quality can enable better informed drilling decisions and thus reduce investment risk for the oil company.

10 [0006] The traditional sensor has long been a geophone velocity measuring sensor. Today, accelerometers are becoming more widely utilized, and multi-axis, or multi-component, accelerometers are emerging. Multi-component (three axis) sensing has shown to give superior images of the subsurface as compared to single component sensing. Multi-component sensing, however,  
15 has not been economically viable in the past due to the added cost of the recording system and implementation problems with multi-component analog sensors. With the advent of the multi-component digital sensor, such as the Vectorseis® sensor module available from Input/Output, Inc., Stafford, Texas, a multi-component digital sensor is now practical. Multi-component recording,  
20 however, requires higher sensor density than single component recording to realize the full advantage seismic imaging with multi-component recording.

[0007] The most popular architecture of current seismic data acquisition systems is a point-to-point cable connection of all of the sensors. Output  
25 signals from the sensors are usually digitized and relayed down the cable lines to a high-speed backbone field processing device or field box. The high-speed backbone is typically connected in a point-to-point relay fashion with other field boxes and then to a central recording system where all of the data are recorded onto magnetic tape.

30 [0008] Seismic data may be recorded at the field boxes for later retrieval, and in some cases a leading field box will communicate command and control

information with the central recorder over a radio link. Still, there exists miles of cabling between the individual field boxes, between the field boxes and sensor lines, and between the sensors.

5       **[0009]** The above cable system architecture results in more than 100 miles of cable deployed over the survey area. The deployment of miles of cable over varying terrain requires significant equipment and labor, often in environmentally sensitive areas.

10       **[0010]** **Figure 1** depicts a typical seismic data acquisition system **100**. The typical system **100** includes an array ("string") of spaced-apart seismic sensor units **102**. Each string of sensors is typically coupled via cabling to a data acquisition device ("field box") **103**, and several data acquisition devices and associated string of sensors are coupled via cabling **110** to form a line **108**,  
15       which is then coupled via cabling **110** to a line tap or ("crossline unit") **104**. Several crossline units and associated lines are usually coupled together and then to a central controller **106** housing a main recorder (not shown). The typical sensor unit **102** in use today is a velocity geophone used to measure acoustic wave velocity traveling in the earth. Recently, and as noted above,  
20       acceleration sensors (accelerometers) are finding more widespread acceptance for measuring acceleration associated with the acoustic wave. Each sensor unit might comprise a single sensor element or more than one sensor element for multi-component seismic sensor units.

25       **[0011]** The sensors **102** are usually spaced at least on the order of tens of meters, e.g., 13.8 - 220.0 feet. Each of the crossline units **104** typically performs some signal processing and then stores the processed signals as seismic information for later retrieval as explained above. The crossline units **104** are each coupled, either in parallel or in series with one of the units **104a**  
30       serving as an interface with between the central controller **106** and all crossline units **104**.

5 [0012] In a conventional cable system data are relayed from one sensor unit to the next sensor unit and through field boxes hundreds of times before reaching the central recording system. Failure of any one field box or cable causes recording to stop until the fault is repaired due to the potential for losing large amounts of information. Consequently, common cable systems have an average uptime of about only 45%.

10 [0013] The basic architecture and reliability issues of the current cable approach described above prevent seismic data acquisition systems from being scaled to significantly higher channel counts. More recent cable systems incorporate different levels of redundancy to address the issue of single-point failure. These redundant systems include multiple redundant backbones, telemetry reversal and other redundancy features. These solutions, however, require even more cable to be deployed on the ground and still limit fault tolerance to no more than two failures in a line that can be many miles long.

20 [0014] Optimal spacing between seismic sensors varies depending on desired image depth and type. When deploying sensors obstacles are often encountered, such as no permit areas, rivers, and roads that cause the seismic crew to use varying spacing between sensor stations. Varying the distance between sensors in a conventional cable system is not convenient due to the fixed interval between connection points. Usually a surveying crew is used to locate the planned position of sensors on the ground prior to laying out the acquisition equipment. A backpack global positioning system ("GPS") receiver is then used by the surveyor and stakes are planted in the ground at each of thousands of predetermined sensor locations. Therefore, array deployment in the typical system is a two-step process adding time and labor costs to the seismic survey process.

30 [0015] In view of the typical seismic data acquisition system described above, there is a need for flexible spacing intervals between sensor units that will

enable easy sharing of equipment between different crews without the worry of incompatible cables due to station interval requirements or to a particular environmental application (e.g., arctic, transition zone, and desert all require different types of cable).

5

[0016] There is also a need for integrating global positioning system (GPS) technology at the sensor unit to eliminate multiple crew process steps for identifying sensor locations and deploying sensors at the location. The typical system suffers, because the sensor unit is not co-located at the data acquisition device, thus the true sensor location is not available to the system for survey analysis.

10

### Summary of the Invention

[0017] The present invention addresses some or all of the problems associated with the conventional cable systems described above and provides a single station radio architecture with independent location of individual wireless sensor stations. This allows both geophysicists and seismic crews to apply the system most efficiently without constraints of fixed station intervals.

15

20

[0018] One aspect of the present invention is an apparatus comprising a sensor unit coupled to the earth for sensing seismic energy in the earth. The sensor unit provides a signal indicative of the sensed seismic energy to an acquisition device co-located with the sensor unit and coupled thereto for receiving the signal. A memory unit is disposed in the acquisition device for storing information indicative of the received signal, and a communication device is co-located with the sensor unit and the acquisition device for providing direct communication with a remotely-located control unit. One or more location parameters are stored in either the central controller and/or the memory unit. The sensor unit might include a multi-axis accelerometer or a velocity sensor such as a geophone. The memory unit is removable in one aspect and might be a memory card or removable hard drive.

25

30

5 [0019] In another aspect of the invention, a method for acquiring seismic information comprises sensing seismic energy in the earth using a sensor unit coupled to the earth and sending a signal indicative of the sensed seismic energy from the sensor unit to an acquisition device co-located with the sensor unit. Then information indicative of the signal is stored in a memory unit disposed in the acquisition device. The method also includes directly communicating with a remotely-located control unit using a communication device co-located with the sensor unit and the acquisition device. One or more location parameters are stored in either the central controller and/or the memory unit.

10

[0020] Another aspect of the present invention is an apparatus for detecting unwanted movement of a remotely-located seismic data acquisition device. The apparatus comprises a sensor disposed in the seismic data acquisition device for detecting movement and to provide a first signal indicative of the movement. A processor is coupled to the sensor for processing the first signal, and the processor provides a second signal indicative of unwanted movement associated with the data acquisition device. A communication device located with the sensor and the acquisition device transmits the second signal to a central controller.

15

20

[0021] A method according to one embodiment of the invention is used for detecting unwanted movement of a remotely-located seismic data acquisition device. The method includes detecting movement using a sensor disposed in the seismic data acquisition device, the sensor providing a first signal indicative of the movement and processing the first signal using a processor coupled to the sensor. The processor provides a second signal indicative of unwanted movement associated with the data acquisition device and transmitting the second signal to a remotely-located central controller using a communication device co-located with the sensor and the acquisition device.

25

30

[0022] Another aspect of the invention is a system for seismic surveying,



5 comprising a central control unit with a sensor unit remotely located from the central control unit, the sensor unit coupled to the earth for sensing seismic energy in the earth and for providing a signal indicative of the sensed seismic energy. A recorder device is co-located with the sensor unit and is coupled thereto for receiving the signal and for storing information indicative of the received signal in a memory disposed in the recorder device. A communication device is co-located with the sensor unit and the acquisition device for providing direct communication with the central control unit. One or more location parameters are stored in either the central controller and/or the recorder device. The system might operate in a passive mode or in an active mode using a seismic energy source.

10  
15 **[0023]** Another aspect of the invention is a method for deploying a sensor unit comprising transporting the sensor unit to a location, deploying the sensor unit, determining location parameters for the sensor unit, and updating system parameters based at least in part on the determined location parameters.

20 **[0024]** Another aspect of the present invention is a system for seismic surveying, comprising a central controller, a plurality of sensors disposed to form a seismic spread having a plurality of sensing locations, and a plurality of recorders, each of the plurality of recorders recording seismic information corresponding to a selected sensing location from the plurality of sensing locations, each of the plurality of recorders being in direct communication with the central controller.

25  
30 **[0025]** Another aspect of the present invention is an apparatus for seismic surveying, comprising a plurality of sensors disposed to form a seismic spread having a plurality of sensing locations, and a plurality of recorders, each of the plurality of recorders recording seismic information corresponding to a selected sensing location from the plurality of sensing locations.

**[0026]** Another aspect of the present invention is an apparatus comprising a

5 sensor unit coupled to the earth for sensing seismic energy in the earth. The sensor unit provides a signal indicative of the sensed seismic energy to an acquisition device co-located with the sensor unit and coupled thereto for receiving the signal. A memory unit is disposed in the acquisition device for storing information indicative of the received signal, and a direct-conversion radio transceiver for providing communication between the acquisition device and a remotely-located central controller.

### 10 Brief Description of the Drawings

[0027] The novel features of this invention, as well as the invention itself, will be best understood from the attached drawings, taken along with the following description, in which similar reference characters refer to similar parts, and in which:

**Figure 1** represents a typical seismic data acquisition system;

**Figure 2** is a conceptual representation of a system according to the present invention;

20 **Figure 3A** shows a schematic representation of the system of figure 2 in more detail;

**Figure 3B** shows one embodiment of a wireless station unit having an integrated seismic sensor;

**Figure 3C** illustrates a multi-component sensor for use in one embodiment of the present invention;

25 **Figure 3D** is a schematic representation of a sensor unit according to the present invention with an optional analog-to-digital converter;

**Figure 4** is a schematic representation of a wireless station unit according to the present invention incorporating circuitry to interface with an analog output sensor unit;

**Figure 5** is a schematic representation of a wireless station unit according to the present invention incorporating circuitry to interface with a digital output sensor unit;

**Figures 6A-6C** show several alternative embodiments of a wireless station unit according to the present invention; and

**Figure 7** shows one method of transferring information stored on a memory card after data acquisition.

### **Detailed Description of the Invention**

**[0028]** **Figure 2** is a conceptual representation of a system according to the present invention. The system **200** includes a central controller **202** in direct communication with each of a number of wireless sensor stations **208** forming an array ("spread") **210** for seismic data acquisition. Each sensor station **208** includes one or more sensors **212** for sensing seismic energy. Direct communication as used herein refers to individualized data flow as depicted in figure 2 by dashed arrows. The data flow can be bi-directional for allowing command and control instructions to be sent from the central controller **202** to each wireless sensor station **208** and for quality control and/or selected pre-processed seismic information to flow from each wireless sensor station **208** to the central controller **202**. The communication might be in the form of radio signals transmitted and received at the central controller **202** via a suitable antenna **204**. The system **200** may operate in a passive mode by sensing natural or random seismic energy traveling in the earth. The system **200** may also operate in an active mode using a seismic energy source **206** to provide seismic energy of a known magnitude and source location.

**[0029]** Certain advantages are apparent from the conceptual representation shown in figure 2. Among other things, the use of individual wireless sensor stations **208** to form the spread **210** eliminates interconnecting cables, such as

the cables **110** associated with the typical line described above and shown in figure 1. Elimination of these cables provides the survey crew the option of moving individual sensors without affecting placement of other sensors in the spread. Another advantage is the reduction of weight in the overall spread. The typical spread requires miles of interconnecting cables that might weigh as much as 55,000 pounds or more. This extreme weight slows the crew and adds cost to deployment in terms of fuel, time and materials.

**[0030]** Another advantage is in the elimination of single-point failures that can cause information loss from at least an entire line of sensors. A failed cable or cable connector, a failed field box, or a failed crossline unit in the typical system of figure 1 will cause such a loss of information. The single station radio architecture of the present invention provides independent communication paths between the acquisition units and the central recording system. The failure of a single radio acquisition unit causes data to be lost from only one station and recording can continue while it is repaired without loss of information from other sensor stations.

**[0031]** **Figure 3A** is a schematic representation of the system **200** in more detail. The central controller **202** includes a computer **300** having a processor **302** and a memory **303**. An operator can interface with the system **200** using a keyboard **306** and mouse or other input **308** and an output device such as a monitor **310**. Communication between remotely-located system components in the spread **210** and the central controller **202** is accomplished using a central transmitter-receiver ("transceiver") unit **312** disposed in the central controller **202** along with an antenna **314**.

**[0032]** The central controller **202** communicates with each wireless sensor station **208**. Each wireless sensor station **208** shown includes a wireless station unit **316**, an antenna **318** compatible with the antenna **314** used with the central controller **202**, and a sensor unit **320** responsive to acoustic energy traveling in the earth co-located with a corresponding wireless sensor station.

Co-located, as used herein, means disposed at a common location with one component being within a few feet of the other. Therefore, each sensor unit **320** can be coupled to a corresponding wireless station unit by a relatively short cable **322**, e.g., about 1 meter in length, or coupled by integrating a sensor unit **320** with the wireless station unit **316** in a common housing **324** as shown in **Figure 3B**.

**[0033]** One sensor for use in a sensor unit **320** might be a multi-component sensor **326** as shown in **Figure 3C**. The multi-component sensor shown includes a three-component accelerometer sensor incorporating micro electro-mechanical systems (MEMS) technology and application-specific integrated circuits (ASIC) as found in the Vectorseis<sup>®</sup> sensor module available from Input/Output, Inc., Stafford, Texas. The present invention, however, does not exclude the option of using velocity sensors such as a conventional geophone or using a pressure sensor such as a conventional hydrophone. Any sensor unit capable of sensing seismic energy will provide one or more advantages of the present invention. Furthermore, the present invention is useful using a single sensor unit **320** as shown, or the sensor unit **320** might include multiple sensors connected in a string.

**[0034]** **Figure 3D** is a schematic representation of a one component **328** in one embodiment of a sensor unit **320**. Those skilled in the art would recognize that a three component sensor to measure seismic energy in multiple axes is realizable by providing additional components substantially similar to the one shown. Therefore, further illustration is not necessary. The sensor component **328** shown includes a sensing element **330** for sensing the seismic energy traveling in the earth. The sensing element detects motion caused by the seismic energy and provides an analog output signal indicative of the motion. The sensor component includes a transmitter/receiver circuit **332** to receive the sensing element output signal and to transmit the output signal to the wireless station unit for further processing, storage and/or for wireless transmission to the central controller. As shown figure 3D by the

dashed lines, an optional analog-to-digital converter ("ADC") 334 might be incorporated into the sensor unit 320 for providing a digital signal from the sensor unit 320. When the sensor unit 320 provides an analog output signal, the wireless station unit 316 might include an ADC for converting the received analog output signal to digital form.

[0035] Figure 4 is a schematic representation of a wireless station unit 400 according to the present invention that operates as a data recorder incorporating circuitry to interface with an analog output sensor unit (not shown). The wireless station unit 400 is an acquisition device that includes a sensor interface 402 to receive an output signal from the sensor unit. The sensor interface 402 shown includes a protection circuit, switch network, a preamplifier, a test oscillator, and ADC and digital filtering circuits to pre-process the received signal. The sensor interface 402 is controlled in part by a field programmable gate array (FPGA) and/or an ASIC controller circuit 404. An on-board local processor 406 processes the signal to create storable information indicative of the seismic energy sensed at the sensor unit. The information can be in digital form for storage in a storage device 408, also referred to herein as a memory unit. The memory unit can be removable as shown at 408 and/or dedicated 408a with a coupling 410 for providing access to the stored information and/or for transferring the stored information to an external storage unit 411. The coupling 410 might be a cable coupling as shown or the coupling might be an inductive coupling or an optical coupling. Such couplings are known and thus are not described in detail.

[0036] The memory 408, 408a can be a nonvolatile memory of sufficient capacity for storing information for later collection or transmission. The memory might be in the form of a memory card, removable miniature hard disk drive, an Electrically-Erasable Programmable Read Only Memory (EEPROM) or the like.

[0037] A memory card, also known as a flash memory card or a storage card,

is a small storage medium used to store digital information and is suitable for use in seismic prospecting. Flash memory is a type of nonvolatile memory that can be erased and reprogrammed in units of memory called blocks. It is a variation of an EEPROM, which unlike flash memory, is erased and rewritten at the byte level. Thus, updating a flash memory is typically faster than updating an EEPROM.

**[0038]** Interface with the central controller **202** is accomplished with a communication device such as an on-board transmitter-receiver circuit **412**, and an antenna **414** selected for the desired transmitting/receiving frequency to provide direct communication with the remotely-located central controller **202**. The transmitter/receiver circuit **412** shown is a direct conversion receiver/synthesizer/transmitter circuit and can alternatively be implemented as a software defined radio transceiver. Alternatively, the transmitter/receiver circuit **412** might be any suitable circuit providing transceiver functions such as a transceiver utilizing superheterodyne technology, for example. The antenna **414** can include a VHF/UHF antenna. Other circuitry might include a radio frequency ("RF") front end circuit **416** and a power amplifier **418** for enhancing communication with the central controller **202**. These circuits might advantageously be in the form of a removable radio band module **419** to allow operation over a broad frequency band when used with replaceable antennas. A direct conversion radio transceiver provides the advantages of operation over a broad frequency band, allows smaller overall size for the station unit **400**, and reduces overall weight for field-transportable units.

**[0039]** Local power is provided by a power supply circuit **420** that includes an on-board rechargeable battery **422**. The battery **422** might be of any suitable chemistry and might be nickel-metal hydride (NMH), a lithium-ion or lithium-polymer rechargeable battery of adequate size for the particular application. The battery provides an output to a power supply **424** to condition and regulate power to downstream circuits and the power supply output is coupled to a power control circuit **426** for distributing power to various local

components.

5 [0040] The power circuit 420 further includes a charging device 428 and charger interface 430 for coupling the charging device 428 to an external power source 431. A charge indicator 432 provides an indication of amount of charge and/or charging time remaining for the power circuit 420. Such indicators are somewhat common and further description is not necessary here.

10 [0041] Location parameters (e.g., latitude, longitude, azimuth, inclination, etc.) associated with a particular wireless sensor station help to correlate data acquired during a survey. These parameters determined prior to a survey using an expected sensor location and nominal sensor orientation and the parameters can be adjusted according to the present invention. The location  
15 parameters are stored in a memory 303, 408 either in the central controller or in the station unit 400. In one embodiment, the wireless sensor station includes a global positioning system ("GPS") receiver 434 and associated antenna 436. The GPS receiver in this embodiment is shown coupled to the processor 406 and to a clock circuit 338 to provide location parameters such  
20 as position and location data for correlating seismic information and for synchronizing data acquisition. Alternatively, location parameters can be transmitted to and stored in the central controller and synchronization may be accomplished by sending signals over the VHF/UHF radio link independent of the GPS. Therefore, the on-board GPS can be considered an optional feature  
25 of the invention. Location parameters associated with sensor orientation can be determined by accelerometers and/or magnetic sensors and/or manually.

30 [0042] In one embodiment, a wake up circuit 444 allows the wireless station unit to control power consumption from the battery throughout different operating modes. The wake up circuit 444 can be triggered from two sources; the radio receiver 412 or the clock 438. In a low power mode, for example, power is applied only to the radio receiver 412 and the wake up circuit 444. If



5 a specific wake up command is transmitted over the radio and decoded by the wake up circuit, other circuits such as the processor **406** will be enabled and come on-line to support further processing of commands and signals received from the sensor unit. Alternatively the wake up circuit could energize the radio receiver **412** at predetermined time intervals as measured by signals received from the clock **438**. At these intervals the radio receiver would be enabled briefly for receiving commands, and if none are received within the enabled time period, the receiver **412** will power down, either autonomously or by command from the wake up circuit.

10 **[0043]** In one embodiment, the wireless station unit **400** further includes a motion sensor **440** to detect unwanted movement of the station unit or to detect around the station unit, in which a proximity sensor might be used. Such unwanted movement might be caused by wildlife interfering with the unit, soil movement or the like. Furthermore, the movement might be indicative of an attempted theft of the station unit. In the latter event, the wireless station unit might also include an audible alarm **442** to deter theft and to keep animals away from the station unit. Any unwanted movement will be detected by the motion sensor, and a motion sensor output is coupled to the unit by a dedicated interface circuit, or the output can be integrated into the sensor interface.

20 **[0044]** The motion sensor output is processed using the on-board processor **406** and the processed output is transmitted via the on-board transmitter/receiver circuit **412** to the central controller to alert the operator of the unwanted movement. The GPS receiver output can be processed along with the motion sensor output. This enables tracking of the wireless sensor station unit in the event of theft.

30 **[0045]** In one embodiment, the function of motion sensing is accomplished with the same sensor unit **208** as is performing the seismic energy sensing function. In the embodiment described above and referring to figure 3B having

the sensor unit integrated into the wireless station unit, the seismic sensor output will necessarily include components associated with the desired sensed seismic activity as well as sensed components associated with unwanted movement. The output is processed in conjunction with the output signal from the GPS receiver to indicate unwanted station movement. Thus, an output signal transmitted to the central controller **202** might include information relating to unwanted movement as well as seismic information, state of health information or other information relating to a particular wireless station unit **316** and/or sensor unit **320**.

**[0046]** Figure 5 is a schematic representation of a wireless station unit ("acquisition device") **500** according to the present invention that operates as a data recorder incorporating circuitry to interface with a digital output sensor unit, such as described above and shown in figure 3D. A sensor interface **502** according to this embodiment does not require an ADC as in the embodiment described above and shown in figure 4, because the signal is already in digital form when received. An ADC, however, might be incorporated for digitizing a motion sensor output from a motion sensor **540**. The sensor interface **502** shown includes a protection circuit with an inductive coupling **502a** and digital filters **502b** to condition the received digital signals and sensor control signals from the FPGA/ASIC control circuit **504**.

**[0047]** Although little or no control of the sensor interface **502** is required in this embodiment, the sensor unit is, controlled in part by a field programmable gate array (FPGA) and/or an ASIC controller circuit **504**. An on-board local processor **506** processes the signal to create storable information indicative of the seismic energy sensed at the sensor unit. The information might be in digital form for storage in a storage device **508**, also referred to herein as a memory unit. The memory unit can be removable as shown at **508** and/or dedicated **508a** with a coupling **510** for providing access to the stored information and/or for transferring the stored information to an external storage unit **511**. The coupling **510** might be a cable coupling as shown or the

coupling might be an inductive coupling or an optical coupling. Such couplings are known and thus are not described in detail.

5 [0048] The memory **508, 508a** can be a nonvolatile memory of sufficient capacity for storing information for later collection or transmission. The memory might be in the form of a memory card, removable miniature hard disk drive, an Electrically-Erasable Programmable Read Only Memory (EEPROM) or the like.

10 [0049] Interface with the central controller **202** is accomplished with a communication device such as an on-board transmitter-receiver circuit **512**, and an antenna **514** selected for the desired transmitting/receiving frequency to provide direct communication with the remotely-located central controller **202**. The transmitter/receiver circuit **512** in one embodiment is a direct  
15 conversion receiver/synthesizer/transmitter circuit and can alternatively be implemented as a software defined radio transceiver. Alternatively, the transmitter/receiver circuit **512** might be any suitable circuit providing transceiver functions such as a transceiver utilizing superheterodyne technology, for example. The antenna **514** can be a VHF/UHF antenna.  
20 Other circuitry might include a radio frequency ("RF") front end circuit **516** and a power amplifier **518** for enhancing communication with the central controller **202**. These circuits might advantageously be in the form of a removable radio band module **519** to allow operation over a broad frequency band when used with replaceable antennas. A direct conversion radio transceiver provides the  
25 advantages of operation over a broad frequency band, allows smaller overall size for the station unit **500**, and reduces overall weight for field-transportable units.

30 [0050] Local power can be provided by a power supply circuit **520** that includes an on-board rechargeable battery **522**. The battery **522** might be of any suitable chemistry, e.g., nickel-metal hydride (NMH), a lithium-ion or lithium-polymer rechargeable battery of adequate size for the particular

application. The battery provides an output to a power supply **524** to condition and regulate power to down-stream circuits and the power supply output is coupled to a power control circuit **526** for distributing power to various local components.

5

**[0051]** The power circuit **520** further includes a charging device **528** and charger interface **530** for coupling the charging device **528** to an external power **531**. A charge indicator **532** provides an indication of amount of charge and/or charging time remaining for the power circuit **520**. Such indicators are somewhat common and further description is not necessary here.

10

**[0052]** Location parameters (e.g., latitude, longitude, azimuth, inclination, etc..) associated with a particular wireless sensor station help to correlate data acquired during a survey. These parameters determined prior to a survey using an expected sensor location and nominal sensor orientation and the parameters can be adjusted according to the present invention. The location parameters are stored in a memory **303**, **508** either in the central controller or in the station unit **500**. In one embodiment, the wireless sensor station includes a global positioning system ("GPS") receiver **534** and associated antenna **536**. The GPS receiver in this embodiment is coupled to the processor **506** and to a clock circuit **538** to provide location parameters such as position and location data for correlating seismic information and for synchronizing data acquisition. Alternatively, location parameters can be transmitted to and stored in the central controller and synchronization may be accomplished by sending signals over the VHF/UHF radio link independent of the GPS. Therefore, the on-board GPS can be considered an optional feature of the invention. Location parameters associated with sensor orientation can be determined by accelerometers and/or magnetic sensors and/or manually.

15

20

25

30

**[0053]** In one embodiment, a wake up circuit **544** allows the wireless station unit to control power consumption from the battery throughout different operating modes. The wake up circuit **544** can be triggered from two sources;

the radio receiver **512** or the clock **538**. In a low power mode, for example, power is applied only to the radio receiver **512** and the wake up circuit **544**. If a specific wake up command is transmitted over the radio and decoded by the wake up circuit, other circuits such as the processor **506** will be enabled and come on-line to support further processing of commands and signals received from the sensor unit. Alternatively the wake up circuit could energize the radio receiver **512** at predetermined time intervals as measured by signals received from the clock **538**. At these intervals the radio receiver would be enabled briefly for receiving commands, and if none are received within the enabled time period, the receiver **512** will power down, either autonomously or by command from the wake up circuit.

**[0054]** In one embodiment, the wireless station unit **500** further includes a motion sensor **540** to detect unwanted movement of the station unit or to detect around the station unit, in which a proximity sensor might be used. Such unwanted movement might be caused by wildlife interfering with the unit, soil movement or the like. Furthermore, the movement might be indicative of an attempted theft of the station unit. In the latter event, the wireless station unit might also include an audible alarm **542** to deter theft and to keep animals away from the station unit. Any unwanted movement will be detected by the motion sensor, and a motion sensor output is coupled to the unit by a dedicated interface circuit, or the output can be integrated into the sensor interface.

**[0055]** The motion sensor output can be digitized using an ADC **541** and the digitized output is processed using the on-board processor **506** and the processed output is transmitted via the on-board transmitter/receiver circuit **512** to the central controller to alert the operator of the unwanted movement. The GPS receiver output can be processed along with the motion sensor output. This enables tracking of the wireless sensor station unit in the event of theft.

5 [0056] In one embodiment, the function of motion sensing is accomplished with the same sensor unit 208 as is performing the seismic energy sensing function. In the embodiment described above and referring to figure 3B having the sensor unit integrated into the wireless station unit, the seismic sensor  
10 output will necessarily include components associated with the desired sensed seismic activity as well as sensed components associated with unwanted movement. The output is processed in conjunction with the output signal from the GPS receiver to indicate unwanted station movement. Thus, an output signal transmitted to the central controller 202 might include information  
15 relating to unwanted movement as well as seismic information, state of health information or other information relating to a particular wireless station unit 316 and/or sensor unit 320.

20 [0057] Figures 6A-6C show several alternative embodiments of a wireless station unit according to the present invention. Figure 6A shows a wireless station unit 600 having a closed housing 602 and integral rechargeable battery 604. A short cable 608 is shown with a sensor connector 616 for interface with a sensor unit. An antenna 610 is coupled to the housing 602. A memory access door 612 is provided to allow access to information stored on local  
25 memory 614. The memory device 614 in one embodiment is removable via the memory access door 612.

30 [0058] Figure 6B shows an embodiment of a wireless station unit 620 that is substantially similar to the embodiment shown in figure 6A. The battery pack 622, however is removable with respect to a housing 624. An advantage here is that a fully charged battery pack can be transported to the wireless station unit 620 to replace a discharged battery pack without moving the wireless station unit from the deployed location for charging.

[0059] Figure 6C shows an alternate of a wireless station unit 630 that is substantially similar to the embodiments shown in figures 6A-B. A battery pack 632 in this embodiment, however is removable with respect to a housing

5 **634** and further includes a memory card **636**. An advantage of this embodiment is that the memory card **636** with seismic information stored thereon can be replaced with a fresh (empty) memory card simultaneously with battery replacement. It should be understood that any embodiment described according to figures 6A-6C can be easily altered to provide an integral seismic sensor to eliminate the cable **608**.

10 **[0060]** Figure 7 shows one method of transferring information stored on a memory card after data acquisition. An information transfer system **700** includes a transcriber, coupled to a tape drive **704**. The tape drive **704** shown holds a magnetic tape **706**, but any suitable storage medium would suffice for the purposes of the present invention.

15 **[0061]** Once data are written to a memory card **708** in the wireless station units the information must be collected and transcribed onto a common repository for all stations in the survey. This process is accomplished by collecting the removable memory cards or memory card/battery packs depending on the embodiment of the wireless station unit used and transporting the memory card(s) **708** to the transcriber system **700**. The  
20 memory cards are placed in a memory card reader **710** or in a memory card reader plus a battery charger when using an embodiment according to figure 6C. The transcriber **702** reads the data from the memory cards **708** and compiles the data into individual shot records. The transcriber **702** also performs data processing and writes the combined processed data into  
25 electronic files. These files are then transferred to permanent storage media such as the magnetic tape **706** in the tape drive **704**.

30 **[0062]** Alternatively, a transcriber system **700** can be transported to each sensor location rather than having the cards collected as described above. The reader **710** can be of any suitable type for on-site transfer and can be coupled to a station unit via cable, optical or inductive coupling.

**[0063]** In one embodiment, a computer with monitor and printer can be used with the transcriber **702** to display the data on the computer monitor for review and inspection or for plotting the data on paper records.

5 **[0064]** In several alternative embodiments, methods of the present invention are used to sense, record and transfer information from a seismic sensor location to a central recorder. In one embodiment, a wireless station unit substantially as described above and shown in figure 4. Each wireless sensor station is transported to a predetermined spread location. Upon arriving at the  
10 location, viability of the location is determined in real time based on the terrain, obstacles borders etc . . . The location is adjusted where necessary and feasible. If adjusted, location parameters (e.g., latitude, longitude, azimuth, inclination, etc..) associated with the particular wireless sensor station so adjusted are determined and entered as updated system parameters. In one  
15 embodiment, these parameters are determined using a GPS receiver to determine the actual location of the planted sensor unit. Other parameters might be determined with a manual compass used by the crew or by one or more magnetometers in the sensor unit. Parameters might also be determined using multi-component accelerometers for determining orientation  
20 of the planted sensor unit. In one embodiment the updated system parameters are entered by the field crew in the wireless sensor station unit itself. In one embodiment, the updated system parameters are entered at the central controller. In another embodiment, the updated system parameters are entered automatically upon system activation and sensor station wake-up  
25 using location parameters and orientation parameters determined by a GPS receiver, accelerometers, magnetometers, and/or other sensors disposed in the station or sensor unit or both.

30 **[0065]** Referring to **Figures 2-7**, a system **200** according to the present invention includes a central controller **202** remotely located from a plurality of station units **208**. Each station unit **208** includes a sensor unit **320** remotely located from the central controller **202**. Each sensor unit **320** is coupled to the



earth for sensing seismic energy in the earth, which might be natural seismic energy or energy produced from a seismic source **206**. The sensor unit **320** provides a signal indicative of the sensed seismic energy and a recorder device **316** co-located with the sensor unit receives the signal stores  
5 information indicative of the received signal in a memory unit **408** disposed in the recorder device **316**. A communication device **412** is co-located with the sensor unit and the recorder device for providing direct two-way wireless communication with the central controller.

10 **[0066]** While the particular invention as herein shown and disclosed in detail is fully capable of obtaining the objects and providing the advantages hereinbefore stated, it is to be understood that this disclosure is merely illustrative of the presently described embodiments of the invention and that  
15 no limitations are intended other than as described in the appended claims.

**What is claimed is:**

- 1           1.     An apparatus for seismic data acquisition comprising:  
2                 a)     a sensor unit for sensing seismic energy, the sensor unit  
3     providing a signal indicative of seismic energy sensed by the sensor unit;  
4                 b)     an acquisition device co-located with the sensor unit and coupled  
5     thereto for receiving the signal;  
6                 c)     a memory unit having a first memory disposed in the acquisition  
7     device for storing information indicative of the received signal;  
8                 d)     a second memory for storing a location parameter associated  
9     with the sensor unit; and  
10                e)     a communication device for providing direct communication  
11     between the acquisition device and a remotely-located central controller.
  
- 1           2.     An apparatus according to claim 1, wherein the sensor unit and the  
2     acquisition device are housed in a common housing.
  
- 1           3.     An apparatus according to claim 1, wherein the sensor unit and the  
2     acquisition device are coupled together with a cable.
  
- 1           4.     An apparatus according to claim 1, wherein the sensor unit includes  
2     one of a velocity sensor and a pressure sensor.
  
- 1           5.     An apparatus according to claim 1, wherein the sensor unit includes an  
2     accelerometer.
  
- 1           6.     An apparatus according to claim 1, wherein the sensor unit further  
2     comprises a multi-component sensor.
  
- 1           7.     An apparatus according to claim 1, wherein the sensor unit further  
2     comprises a multi-component accelerometer having a digital output signal.

- 1           8.     An apparatus according to claim 1 further comprising an  
2 analog-to-digital converter disposed in the sensor unit, the signal provided by  
3 the sensor unit including a digital signal.
- 1           9.     An apparatus according to claim 1, wherein the signal is an analog  
2 signal, the apparatus further comprising an analog-to-digital converter  
3 disposed in the acquisition device for converting the signal to digital data.
- 1           10.    An apparatus according to claim 1, wherein the first memory further  
2 comprises a nonvolatile memory.
- 1           11.    An apparatus according to claim 1, wherein the first memory further  
2 comprises a removable memory.
- 1           12.    An apparatus according to claim 1, wherein the first memory further  
2 comprises one or more of a miniature hard disk drive and a nonvolatile  
3 removable memory card.
- 1           13.    An apparatus according to claim 1, wherein the memory unit includes  
2 an inductive coupling device for transferring the information stored in the  
3 memory unit to an external device.
- 1           14.    An apparatus according to claim 1, wherein the memory unit includes  
2 an optical coupling device for transferring the information stored in the  
3 memory unit to an external device.
- 1           15.    An apparatus according to claim 1, wherein the sensor unit is coupled  
2 to the acquisition device using a sensor connector, the memory unit also being  
3 coupled to the sensor connector for enabling retrieval of the information stored  
4 in the memory unit using the sensor connector.

1           16.    An apparatus according to claim **1**, wherein communication with the  
2           remotely-located central controller provides wireless command and control for  
3           the apparatus.

1           17.    An apparatus according to claim **1** further comprising a processor  
2           associated with the acquisition unit and the communication device, the  
3           processor processing programmed instructions enabling a software-defined  
4           radio transceiver.

1           18.    An apparatus according to claim **1**, wherein the communication device  
2           includes a direct conversion radio transceiver for wireless communication  
3           between the apparatus and the remotely-located central controller.

1           19.    An apparatus according to claim **1** further comprising a processor in the  
2           acquisition unit for providing one or more of local control, time keeping, and  
3           power management.

1           20.    An apparatus according to claim **1** further comprising a power source  
2           disposed in the acquisition device for providing electrical power to one or more  
3           of the acquisition device, the sensor unit and the communication device.

1           21.    An apparatus according to claim **20**, wherein the power source is  
2           removable.

1           22.    An apparatus according to claim **20**, wherein the power source includes  
2           a rechargeable battery.

1           23.    An apparatus according to claim **22** further comprising an inductive  
2           coupling in the acquisition device, the inductive coupling being operably  
3           coupled to the rechargeable battery to allow charging of the rechargeable  
4           battery by a second power source external to the acquisition device.

1           24.    An apparatus according to claim **22** further comprising a connector  
2           disposed in the data acquisition device, the connector being operably coupled  
3           to the rechargeable battery to allow charging of the rechargeable battery by a  
4           second power source external to the acquisition device.

1           25.    An apparatus according to claim **22**, wherein the rechargeable battery  
2           comprises one or more of a nickel-metal hydride battery, a lithium-ion battery,  
3           and a lithium-polymer battery.

1           26.    An apparatus according to claim **1**, further comprising a GPS receiver  
2           associated with the sensor unit for determining the location parameter.

1           27.    A method for for seismic data acquisition comprising:

- 2           a)     sensing seismic energy in the earth using a sensor unit coupled  
3           to the earth;  
4           b)     sending a signal indicative of the sensed seismic energy from the  
5           sensor unit to an acquisition device co-located with the sensor unit;  
6           c)     storing information indicative of the signal in a first memory  
7           disposed in the acquisition device;  
8           d)     storing a location parameter in a second memory; and  
9           e)     directly communicating with a remotely-located central controller  
10          using a communication device co-located with the sensor unit and the  
11          acquisition device.

1           28.    A method according to claim **27**, wherein the sensor unit is selected  
2           from one of a velocity sensor and a pressure sensor.

1           29.    A method according to claim **27**, wherein the sensor unit includes an  
2           accelerometer and signal is indicative of a sensed acceleration of the seismic  
3           energy.

1           30.    A method according to claim **27**, wherein the sensor unit further  
2           comprises a multi-component sensor and the signal is indicative of movement  
3           in at least two directions.

1           31.    A method according to claim **27**, wherein sending the signal includes  
2           sending a digital signal from the sensor unit.

1           32.    A method according to claim **27**, wherein sending the signal includes  
2           sending an analog signal from the sensor unit, the method further comprising  
3           digitizing the analog signal in the acquisition device.

1           33.    A method according to claim **27**, wherein storing information in the  
2           memory unit includes storing the information in a non-volatile memory.

1           34.    A method according to claim **27**, wherein the memory unit further  
2           comprises a removable memory, the method further comprising removing a full  
3           memory unit from the acquisition device to allow replacement of the full  
4           memory unit with an empty memory unit.

1           35.    A method according to claim **27**, wherein the memory unit includes an  
2           inductive coupling device, the method further comprising transferring the  
3           information stored in the memory unit to an external device using the inductive  
4           coupling device.

1           36.    A method according to claim **27**, wherein the memory unit includes an  
2           optical coupling device, the method further comprising transferring the  
3           information stored in the memory unit to an external device using the optical  
4           coupling device.

1           37.    A method according to claim **27**, wherein the sensor unit is coupled to  
2           the acquisition device using a sensor connector, the memory unit also being  
3           coupled to the sensor connector, the method further comprising retrieving the

4 information stored in the memory unit using the sensor connector.

1 38. A method according to claim **27**, wherein communicating with the  
2 remotely-located unit includes wireless communication of command and  
3 control signals for the acquisition device.

1 39. A method according to claim **27** further comprising providing one or  
2 more of local control, time keeping, and power management using a processor  
3 disposed in the acquisition unit.

1 40. A method according to claim **27** further comprising providing power to  
2 one or more of the acquisition device, the sensor unit and the communication  
3 device using a power source disposed in the acquisition device.

1 41. A method according to claim **40**, wherein the power source includes a  
2 rechargeable battery, the method further comprising recharging the  
3 rechargeable battery using a second power source external to the acquisition  
4 device and coupled to the acquisition device using one of a connector and an  
5 inductive coupling.

1 42. A method according to claim **27** further comprising providing a time  
2 keeping function using a clock circuit and processor disposed in the acquisition  
3 device.

1 43. A method according to claim **42**, wherein a seismic data acquisition  
2 session is initiated by the time keeping circuit.

1 44. A method according to claim **27** further comprising providing  
2 synchronization information to the acquisition device for time keeping from the  
3 remotely-located central controller.

1 45. A method according to claim **27** further comprising initiating a seismic  
2 data acquisition session from the remotely-located central controller.

1 46. A method according to claim **27** further comprising sending recording  
2 status information from the acquisition device to the remotely-located central  
3 controller in real time over a wireless communication link.

1 47. A method according to claim **27** further comprising sending the  
2 information from the acquisition device to the remotely-located central  
3 controller in real time over a wireless communication link.

1 48. An apparatus for detecting unwanted movement of a remotely-located  
2 seismic data acquisition device, comprising:

3 a) a sensor disposed in the seismic data acquisition device for  
4 detecting movement, the sensor providing a first signal indicative of the  
5 movement;

6 b) a processor coupled to the sensor for processing the first signal,  
7 the processor providing a second signal indicative of unwanted movement of  
8 the data acquisition device;

9 c) a communication device located with the sensor and the  
10 acquisition device to transmit the second signal to a central controller.

1 49. An apparatus according to claim **48**, wherein the communication device  
2 is a wireless communication device.

1 50. An apparatus according to claim **48**, wherein the sensor is acoustically  
2 coupled to the earth to sense seismic energy in the earth, the second signal  
3 being further indicative of seismic energy in the earth.

1 51. An apparatus according to claim **48** further comprising a second sensor  
2 acoustically coupled to the earth to sense seismic energy in the earth, the  
3 second sensor providing a third signal indicative of the sensed seismic energy.



4           52.    An apparatus according to claim **51**, wherein the first signal and third  
5           signal are combined and the second signal includes the combined first signal  
6           and third signal.

1           53.    An apparatus according to claim **48**, wherein the sensor includes an  
2           accelerometer.

1           54.    An apparatus according to claim **48**, wherein the sensor includes a  
2           multi-axis accelerometer.

1           55.    A method for detecting unwanted movement of a remotely-located  
2           seismic data acquisition device, comprising:

3                 a)    detecting movement using a sensor disposed in the seismic data  
4           acquisition device, the sensor providing a first signal indicative of the  
5           movement;

6                 b)    processing the first signal using a processor coupled to the  
7           sensor, the processor providing a second signal indicative of unwanted  
8           movement of the data acquisition device;

9                 c)    transmitting the second signal to a remotely-located central  
10          controller using a communication device co-located with the sensor and the  
11          acquisition device.

1           56.    A method according to claim **55**, wherein transmitting the second signal  
2           includes transmitting the second signal using a wireless communication link.

1           57.    A method according to claim **55** further comprising sensing seismic  
2           energy in the earth using the sensor, the second signal being further indicative  
3           of seismic energy in the earth.

1           58.    A method according to claim **55** further comprising sensing seismic  
2           energy in the earth using a second sensor, the second sensor providing a third  
3           signal indicative of the sensed seismic energy.

1 59. A method according to claim 58 further comprising combining the first  
2 signal and third signal, the second signal including the combined first signal  
3 and third signal.

1 60. A method according to claim 55, wherein detecting movement includes  
2 sensing acceleration with an accelerometer having one or more axes of  
3 sensitivity.

1 61. A system for seismic surveying, comprising:  
2 a) a central controller;  
3 b) a sensor unit remotely located from the central controller, the  
4 sensor unit coupled to the earth for sensing seismic energy in the earth and for  
5 providing a signal indicative of the sensed seismic energy;  
6 c) a recorder device co-located with the sensor unit and coupled  
7 thereto for receiving the signal and for storing information indicative of the  
8 received signal in a first memory disposed in the recorder device;  
9 d) a second memory for storing a location parameter associated  
10 with the sensor unit; and  
11 e) a communication device co-located with the sensor unit and the  
12 recorder device for providing direct communication with the central controller.

1 62. A system according to claim 61 further comprising an energy source for  
2 providing the seismic energy in the earth.

1 63. A system according to claim 61, wherein the communication device  
2 includes a two-way wireless transceiver for wireless communication with the  
3 central controller.

1 64. An apparatus for seismic data acquisition comprising:  
2 a) a sensor unit coupled to the earth for sensing seismic energy in  
3 the earth, the sensor unit providing a signal indicative of the sensed seismic

- 4 energy; and
- 5 b) a wireless seismic recorder co-located with the sensor unit and
- 6 coupled thereto for receiving the signal, the wireless seismic recorder
- 7 including,
- 8 a memory unit for storing information indicative of the received
- 9 signal and a wireless communication device for providing direct wireless
- 10 communication with a remotely-located central controller; and
- 11 c) a second memory for storing a location parameter associated
- 12 with the sensor unit.

- 1 65. A method for seismic data acquisition comprising:
- 2 a) transporting a seismic sensor unit to a seismic survey location;
- 3 b) deploying the seismic sensor unit;
- 4 c) determining one or more location parameters for the sensor unit;
- 5 d) updating one or more system parameters based at least in part
- 6 on the determined location parameters; and
- 7 e) sensing seismic energy using the seismic sensor.

- 1 66. A method according to claim 65, wherein updating the one or more
- 2 system parameters includes entering a system parameter at the sensor unit
- 3 location.

- 1 67. A method according to claim 65, wherein updating one or more system
- 2 parameters includes a system parameter at a central controller.

- 1 68. A method according to claim 65, wherein updating one or more system
- 2 parameters includes automatically entering a system parameter using one or
- 3 more devices in the sensor unit to determine the location parameters upon
- 4 activation of the sensor unit.

- 1 69. A system for seismic data acquisition comprising:
- 2 a) a central controller;

3           b)     a plurality of sensors disposed to form a seismic spread having a  
4 plurality of sensing locations;

5           c)     a plurality recorders, each of the plurality of recorders recording  
6 seismic information corresponding to a selected sensing location from the  
7 plurality of sensing locations, each of the plurality of recorders being in direct  
8 communication with the central controller.

1       70.    An apparatus for seismic data acquisition comprising:

2           a)     a plurality of sensors disposed to form a seismic spread having a  
3 plurality of sensing locations; and

4           b)     a plurality recorders, each of the plurality of recorders recording  
5 seismic information corresponding to a selected sensing location from the  
6 plurality of sensing locations.

1       71.    An apparatus for seismic data acquisition comprising:

2           a)     a sensor unit for sensing seismic energy, the sensor unit  
3 providing a signal indicative of the sensed seismic energy;

4           b)     an acquisition device co-located with the sensor unit and coupled  
5 thereto for receiving the signal;

6           c)     a memory unit disposed in the acquisition device for storing  
7 information indicative of the received signal; and

8           d)     a direct-conversion radio transceiver for providing communication  
9 between the acquisition device and a remotely-located central controller.

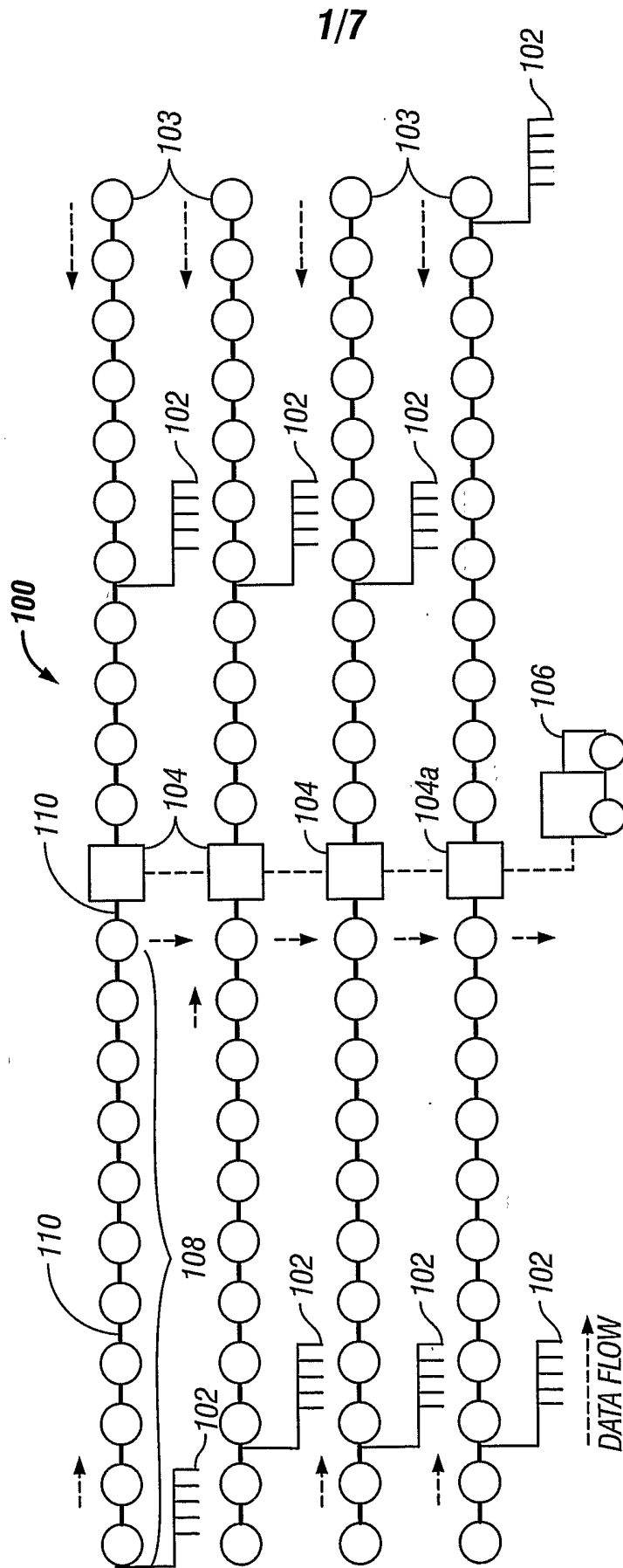

**FIG. 1**  
**(Prior Art)**

2/7

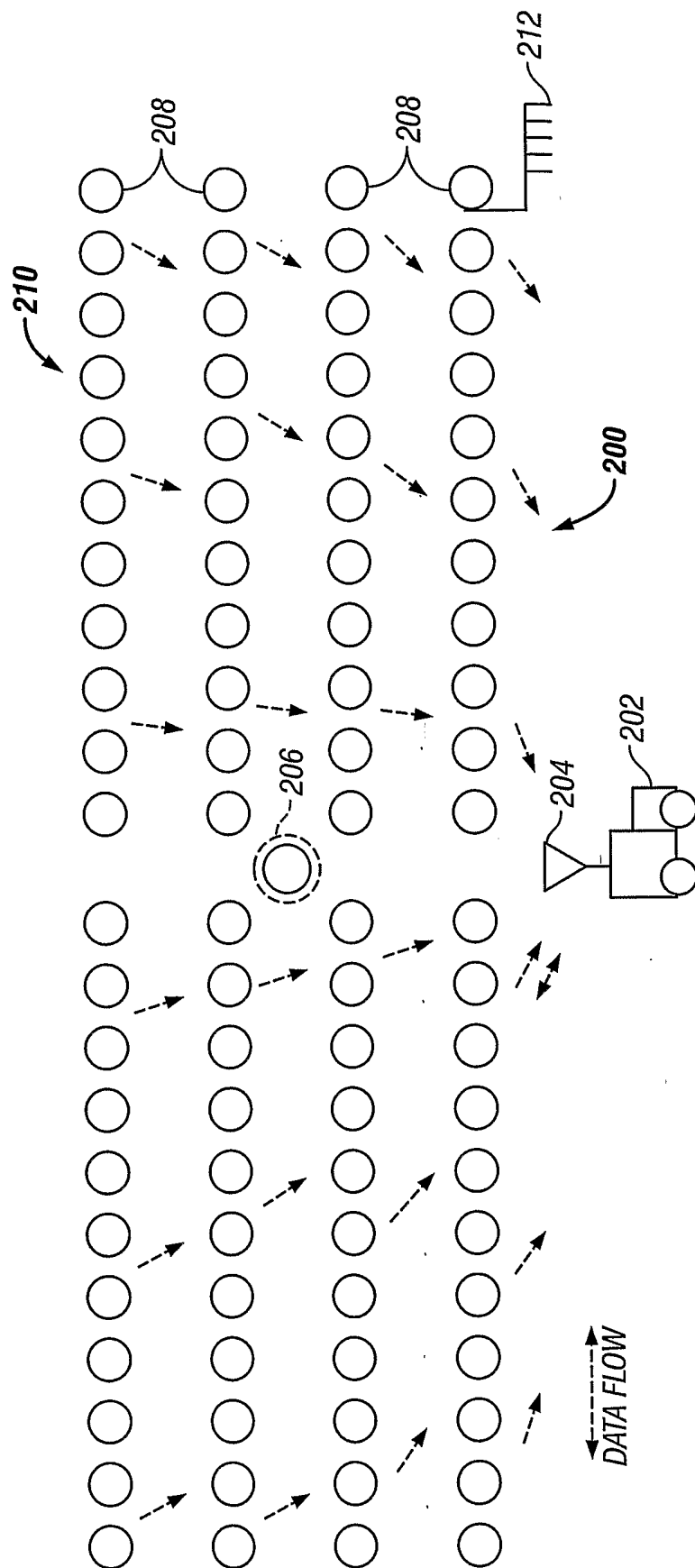

FIG. 2

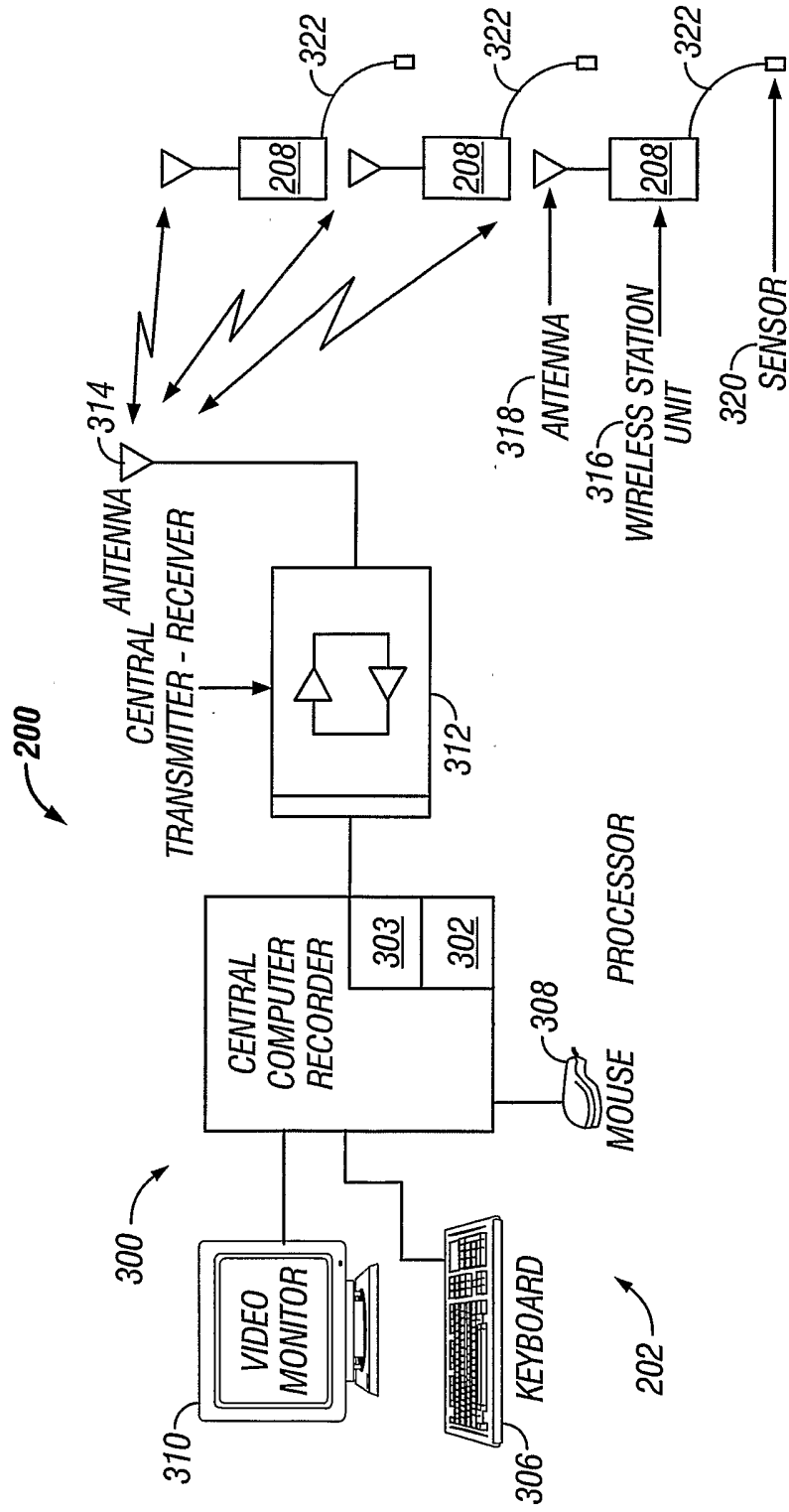

FIG. 3A

4/7

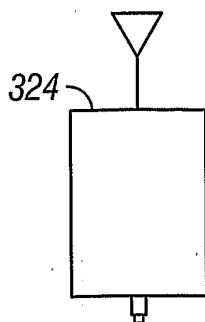

FIG. 3B

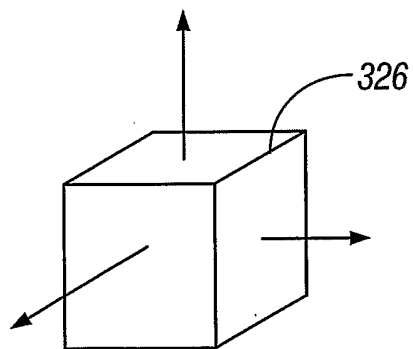

FIG. 3C

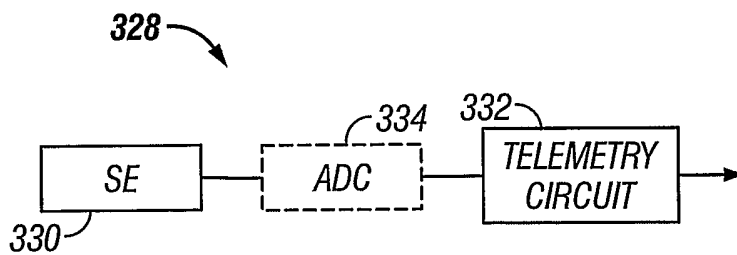

FIG. 3D



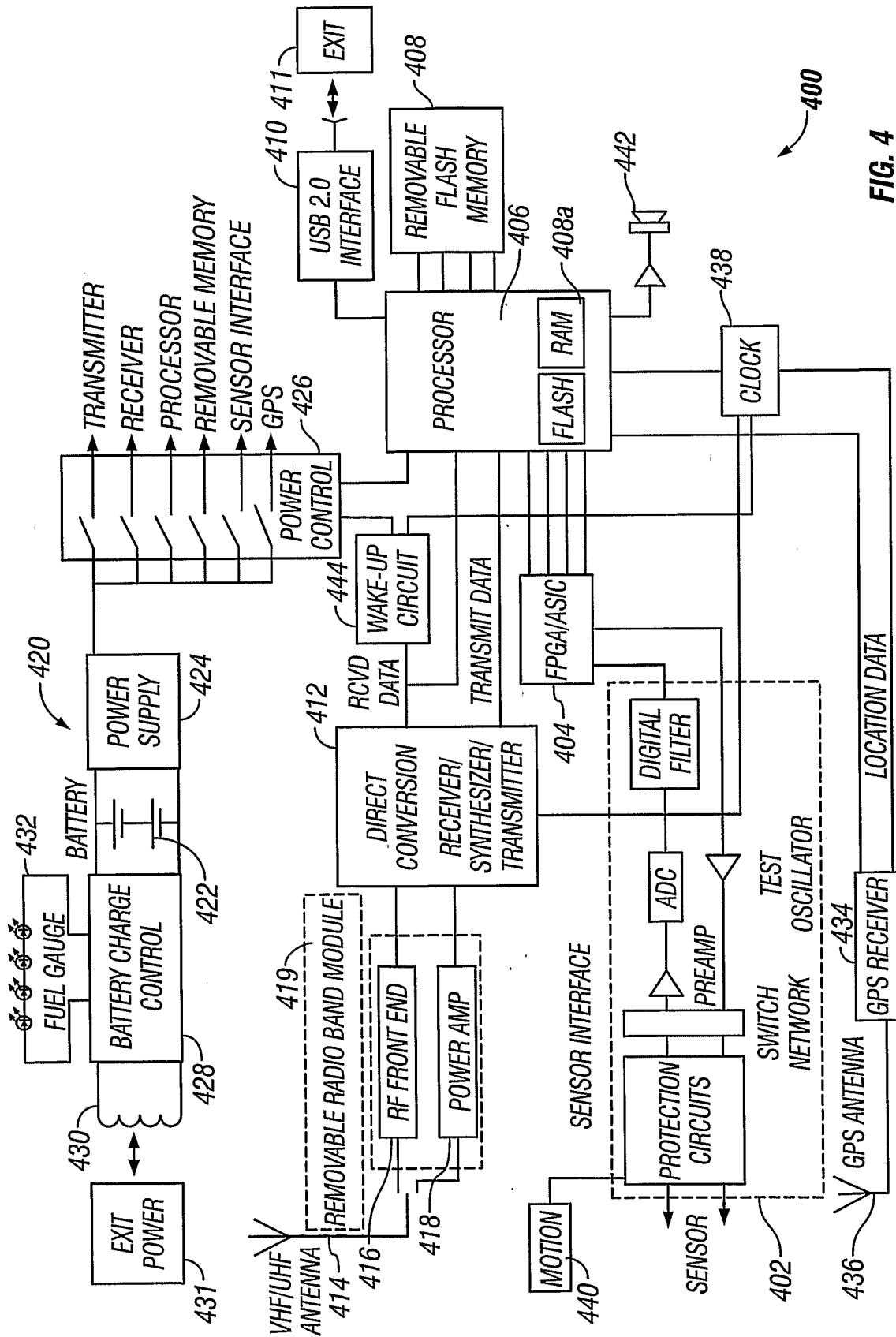

FIG. 4

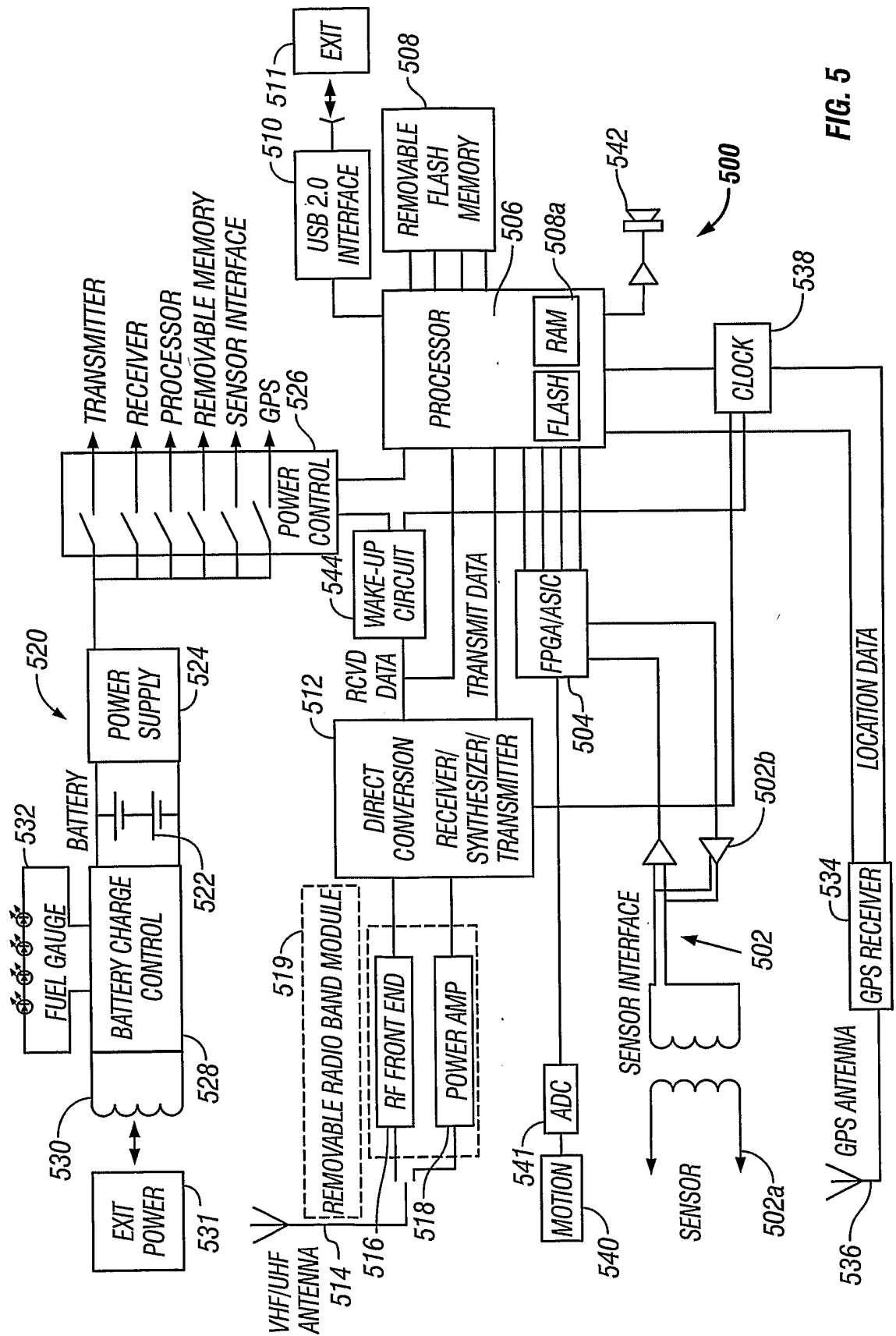

FIG. 5

7/7

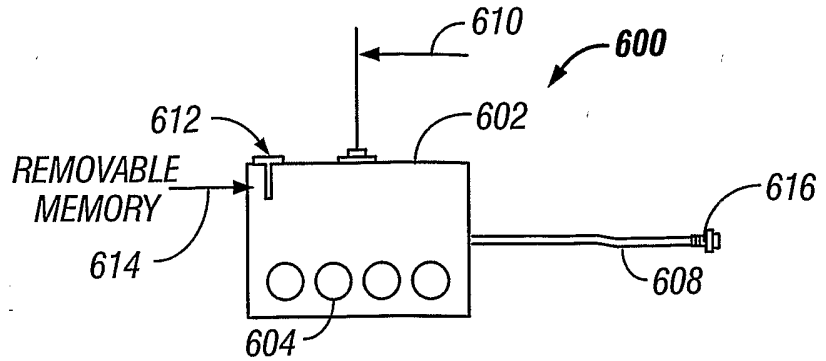

FIG. 6A

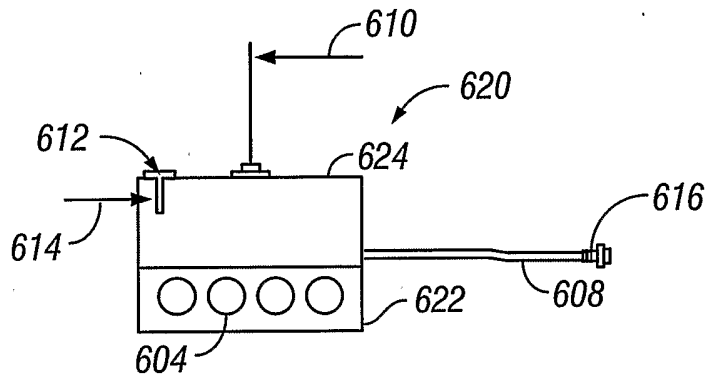

FIG. 6B

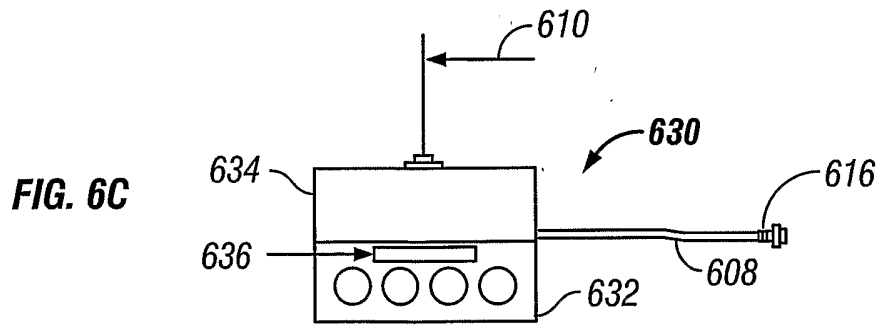

FIG. 6C

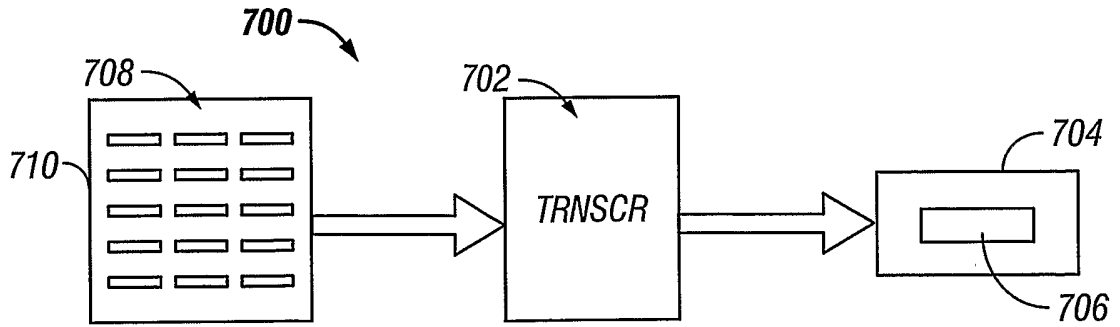

FIG. 7