

(No Model.)

2 Sheets—Sheet 1.

W. H. DIXON.  
ROCK DRILL.

No. 524,993.

Patented Aug. 21, 1894.

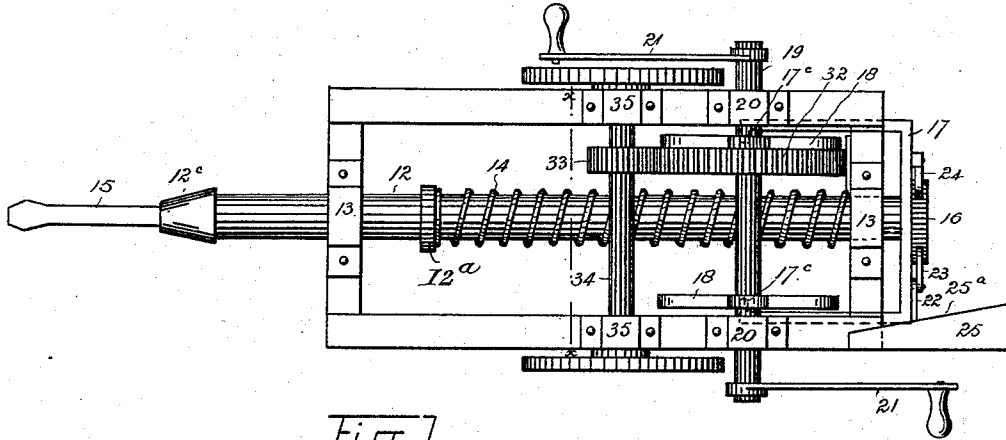

Fig. 1.

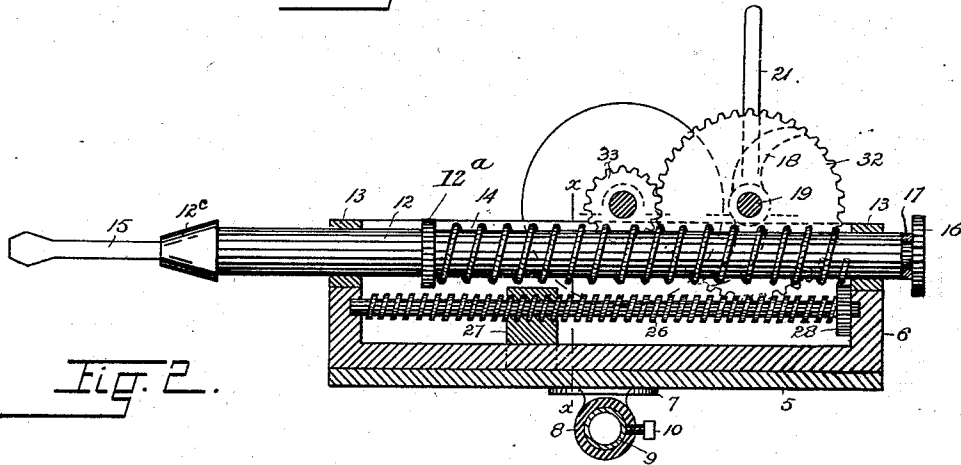

Fig. 2.

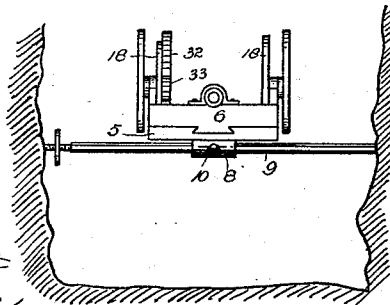

Fig. 3.

WITNESSES:

*G. J. Ollaudet*  
*Chas. E. Dawson.*

INVENTOR

*W. H. Dixon*

BY

*A. J. O'Brien*

ATTORNEY

(No Model.)

2 Sheets—Sheet 2.

W. H. DIXON.  
ROCK DRILL.

No. 524,993.

Patented Aug. 21, 1894.

Fig. 4.

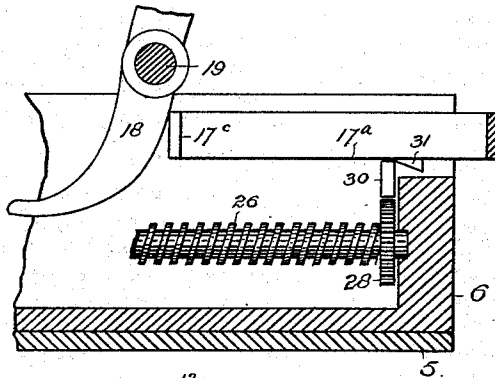

Fig. 5.

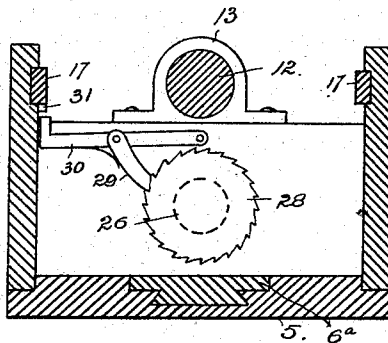

Fig. 6.

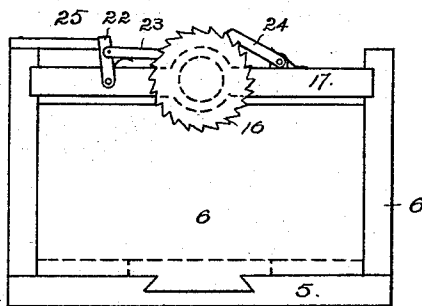
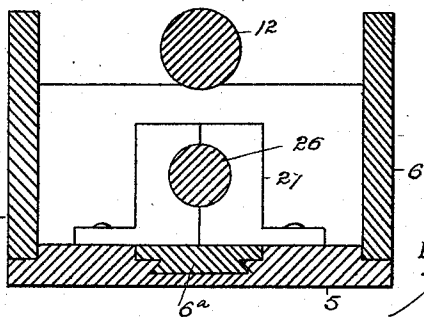

Fig. 7.



WITNESSES:

*G. J. DeLauder*  
*Chas. E. Dawson*

INVENTOR

*W. H. Dixon*

BY

*A. J. Min*  
ATTORNEY

# UNITED STATES PATENT OFFICE.

WILLIAM H. DIXON, OF DENVER, COLORADO, ASSIGNOR, BY DIRECT AND MESNE ASSIGNMENTS, OF ELEVEN-SIXTEENTHS TO CHARLES E. GARTMAN AND FRANK A. JOSLIN, OF SAME PLACE.

## ROCK-DRILL.

SPECIFICATION forming part of Letters Patent No. 524,993, dated August 21, 1894.

Application filed February 27, 1894. Serial No. 501,744. (No model.)

*To all whom it may concern:*

Be it known that I, WILLIAM H. DIXON, a citizen of the United States of America, residing at Denver, in the county of Arapahoe and State of Colorado, have invented certain new and useful Improvements in Rock-Drills; and I do declare the following to be a full, clear, and exact description of the invention, such as will enable others skilled in the art to which it appertains to make and use the same, reference being had to the accompanying drawings, and to the figures of reference marked thereon, which form a part of this specification.

My invention relates to improvements in rock drills specially designed for operation by hand power; and the same consists of the features, arrangements and combinations hereinafter described and claimed, all of which will be fully understood by reference to the accompanying drawings in which is illustrated an embodiment thereof.

In the drawings, Figure 1 is a top or plan view of the drill. Fig. 2 is a side elevation partly in section. Fig. 3 is an end elevation of the drill, shown on a reduced scale, and in position for use. Fig. 4 is a fragmentary view of the drill shown partly in section, and partly in side elevation. Fig. 5 is a cross-section of the frame, the ratchet made fast on the feed screw, and its operating mechanism, being shown in elevation. Fig. 6 is a rear, end elevation of the machine. Fig. 7 is a cross-section taken through the framework, the ram and the feed screw, on the line  $x-x$ , Figs. 1 and 2.

Similar reference characters indicate corresponding parts or elements of the mechanism in the several views.

Let the numeral 5 designate the stationary frame or track upon which the movable frame 6 travels during the operation of the machine. The frame 5 is made fast to a base 7, the latter being attached to a sleeve 8, adjustably secured to a hollow shaft 9 by means of a set screw 10; this mechanism allows two adjustments, whereby the direction and angle of inclination may be changed at will. The frame 6 carries a longitudinal dovetailed

tongue 6<sup>a</sup> centrally located and engaging a groove of corresponding shape formed in the base or stationary frame 5. Upon the frame 6 is mounted the ram 12 which is journaled in boxes 13. This ram is surrounded by a coil-spring 14 which bears against a collar 12<sup>a</sup> at one extremity and a journal box 13 at the opposite extremity. One extremity of the ram carries a chuck 12<sup>c</sup> in which the drilling tool or bit 15 is inserted; while the opposite end of the ram carries a ratchet head 16 engaged by a forked frame 17 through which the reduced extremity of the ram passes. The arms 17<sup>a</sup> of the fork engage grooves formed in the sides of the frame 6 in which they are adapted to slide. The extremities of the arms are turned inward as shown at 17<sup>b</sup> to form bearing surfaces for the cams 18 mounted on the shaft 19 which is journaled in boxes 20 on frame 6.

Suitable hand cranks 21 are attached to the shaft 19. As this shaft is rotated, the frame 17 is engaged by the cams 18, whereby the ram is alternately forced backward and released. As the ram is carried backward by the forked frame, the spring 14 is placed under tension, while the recoil of the spring, as soon as the ram is released, carries the latter forcibly backward, and delivers the blow against the rock through the medium of the drill bit 15.

The necessary partial rotation of the drill bit between strokes is obtained through the instrumentality of actuating mechanism connected with the ratchet 16 of the ram. This actuating mechanism consists of a lever 22 fulcrumed on the frame 17; an actuating pawl 23 engaging the ratchet head, and to which the lever is pivoted; and a locking pawl 24 also engaging said head. The lever 22 is in turn actuated by a cam 25 made fast on the frame 6, and provided with an inclined face 25<sup>a</sup> engaging the lever. The cam 25 is widest at its rear extremity; hence, every time the frame 17 moves backward (the cam being relatively stationary) the ram, together with the drill bit, is given a partial rotation preparatory to delivering the blow. The forward longitudinal movement of the frame 6

(or the feed of the ram) is accomplished through the medium of a screw shaft 26 journaled in the ends of the frame 6 below the ram and engaging a divided nut 27 attached to the stationary frame 5. This screw shaft carries a ratchet disk 28 which is engaged by a pawl 29 pivoted on a lever 30 fulcrumed on the frame 6 and having its free extremity located in the path of a cam 31 made fast on one arm of the frame 17. It will be observed that as the screw shaft 26 is actuated, the frame 6 is carried forward. This forward movement of the frame, however, does not determine the feed of the ram and drill bit; in other words, the frame 6 may get ahead of the ram, since the forward movement of the latter is determined by the structure of the rock engaged by the bit. Now, if by reason of the hardness of the rock, the frame gets in advance, or too far ahead of the ram, the cam 31 will cease to engage the lever 30, since the forward movement of the frame 17, at each stroke of the ram, is limited by the movement of the latter; hence the frame 6 will wait for the ram, so to speak, until the latter has reached the proper position relatively to the frame, when the cam 31 will again engage the lever 30, depress the pawl 29, impart a partial rotation to the screw shaft and move the frame 6 forward a certain distance. Hence the forward movement of the frame 6 is automatically regulated to harmonize with the progress of the ram and drill bit, which will, of course, depend upon the condition of the rock. Mounted on the cam shaft 19, is a gear 32 meshing with a smaller gear 33 on a shaft 34 journaled in the frame 6 by means of boxes 35, and carrying fly wheels 36 made fast to its extremities outside the frame.

From the foregoing description, the operation of my improved rock drill will be readily understood. The cam shaft is rotated by the use of the cranks 21. The cams 18 are thus made to engage the extremities 17° of the forked frame 17, whereby said frame, and the ram, or reciprocating shaft 12, are alternately carried backward and suddenly released. As soon as the ram is released, the recoil of the spring 14 carries it forcibly forward. As the frame 17 reciprocates, the feed mechanism, and the mechanism for imparting the partial rotation to the ram and drill bit, are operated.

Having thus described my invention, what I claim is--

In a rock drill, the combination with the movable and stationary frames, of the spring-actuated ram slidably mounted on the movable frame, a frame 17 slidably attached to the movable frame and reciprocating with the ram to which it is attached, and feed mechanism consisting of a screw shaft journaled in the movable frame and carrying a ratchet disk, a nut made fast in the stationary frame and through which said shaft passes, a lever fulcrumed on the movable frame, a pawl pivoted on the lever and engaging the ratchet disk, and a cam consisting of a plate attached to the frame 17 and having an inclined edge adapted to engage the lever, substantially as described.

In testimony whereof I affix my signature in the presence of two witnesses.

WILLIAM H. DIXON.

Witnesses:

G. J. ROLLANDET,  
CHAS. E. DAWSON.