

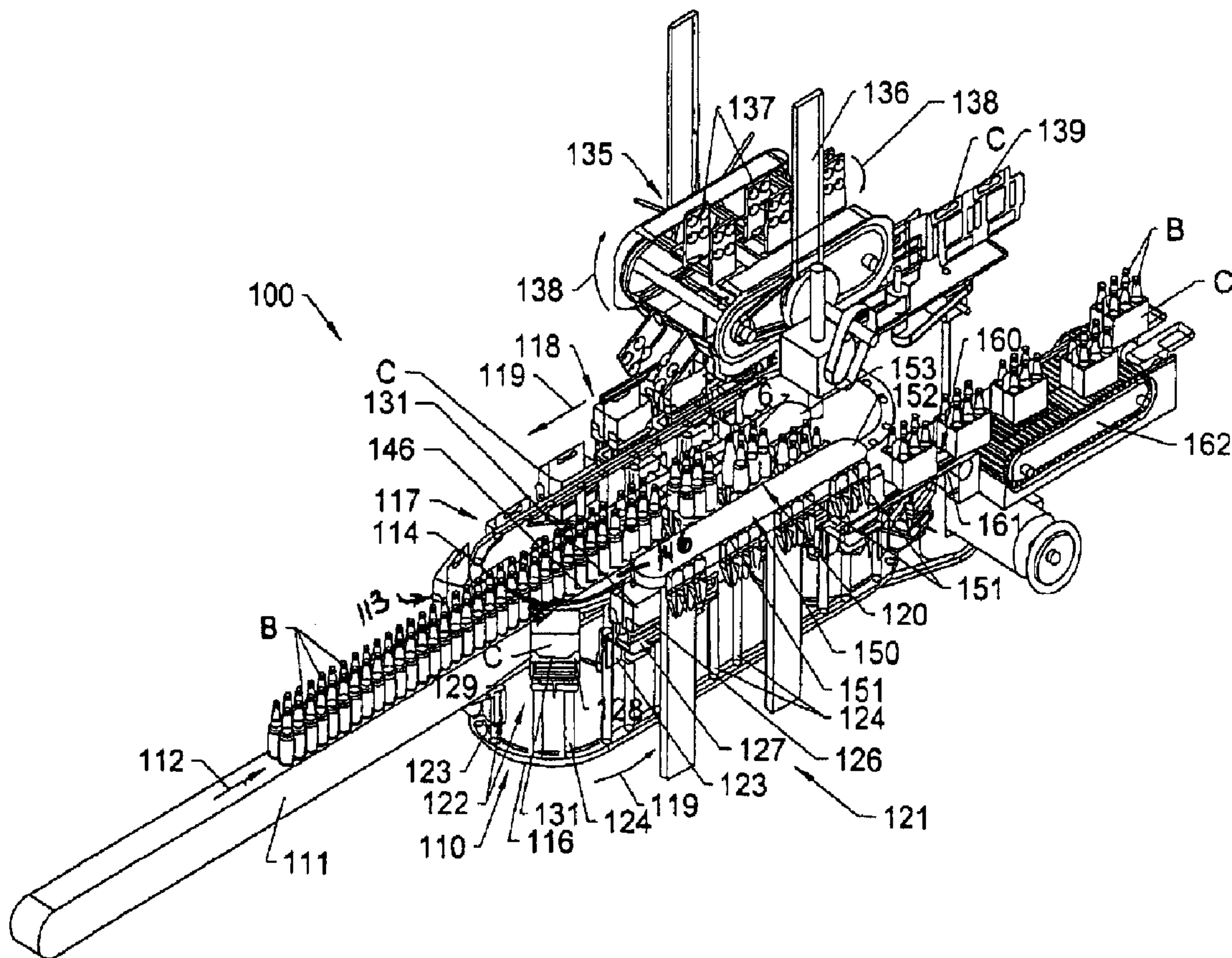

(22) Date de dépôt/Filing Date: 2007/04/27
 (41) Mise à la disp. pub./Open to Public Insp.: 2007/11/29
 (62) Demande originale/Original Application: 2 650 249
 (30) Priorité/Priority: 2006/05/19 (US11/437,394)

(51) Cl.Int./Int.Cl. *B65B 21/14* (2006.01),
B65B 21/02 (2006.01), *B65B 21/22* (2006.01)
 (71) Demandeur/Applicant:
GRAPHIC PACKAGING INTERNATIONAL, INC., US
 (72) Inventeur/Inventor:
FORD, COLIN P., US
 (74) Agent: MACRAE & CO.

(54) Titre : SYSTEME D'EMBALLAGE AVEC CARROUSEL DE CHARGEMENT
 (54) Title: PACKAGING SYSTEM HAVING LOADING CAROUSEL



(57) **Abrégé/Abstract:**

A packaging system utilizes two sides of a loading carousel, which reduces both the height and footprint of the packaging system. Mass and inertia are also reduced, allowing higher operational speeds. The loading carousel receives opened cartons on a first side and lowers them over product groups on a second side.

ABSTRACT

A packaging system utilizes two sides of a loading carousel, which reduces both the height and footprint of the packaging system. Mass and inertia are also reduced, allowing higher operational speeds. The loading carousel receives opened cartons on a first side and lowers them over product groups on a second side.

PACKAGING SYSTEM HAVING LOADING CAROUSEL

[0001] This application is a division of copending Canadian Patent Application Serial No. 2,650,249, filed April 27, 2007.

TECHNICAL FIELD

[0002] The present invention relates generally to a high speed packaging machine having a loading carousel.

BACKGROUND

[0003] The packaging of articles such as bottles, cans, and other similar articles in cartons or other containers is a highly automated process, with conventional automated packaging equipment generally being run at high packaging speeds in order to maximize output. In a typical packaging machine for packaging articles such as bottles, cans and the like, articles to be packaged are fed into the packaging machine in a line or series of lines along an infeed conveyor, after which the articles are grouped together in various standard configurations or groupings, such as four, six, eight, twelve, or twenty-four pack configurations. The groups of articles are then

packaged into a box, a carton, or other type of container. The placement of the articles within a container can be done in a variety of ways, depending upon the type of package in which the articles are to be placed. For example, the bottoms of cartons can be opened and the cartons then placed over selected groups of articles as the articles are moved along a transport path.

[0004] A conventional packaging machine is shown in **FIG. 1**. The machine functions generally are performed in a line extending through the machine. As shown in **FIG. 1**, product metering is operated by star wheels at Station 1. At Station 2, product selection blocks separate the product into groups to be loaded into individual cartons. At Station 3, a carousel pick-up selects individual cartons for loading. At Station 4, a carton transport controls the carton through plows and an opening assembly. At Station 5, the carton opener opens the cartons between pairs of vacuum manifold assemblies. At Station 6, the carousel vertically lowers the opened cartons over and onto the product groups. At Station 7, a closing section closes the carton base about the bottle group contained therein and compression is applied on the underside of the discharge belt to secure the carton in a closed position.

[0005] Given the high speeds at which the packaging machine is operated, the linear footprint of the machine must be large in order to ensure that the path of travel of the cartons is sufficient to ensure that the cartons are fully opened before being placed over a group of articles. However, plant space often is at a premium and it is not always possible to extend machinery to an optimal size. To prevent jams or misfeeds, the speed at which the articles are packaged must then typically be reduced in order to

ensure that the cartons are fully opened prior to packaging the articles therein. Output is accordingly reduced.

[0006] Even in cases where the linear extent of the packaging machine is not limited, a large loading carousel necessarily has a large mass of moving parts, which entails a correspondingly large inertia during operation. Drive mechanisms must therefore be larger, and high speed operation of the larger machine may result in higher maintenance costs, higher rates of failure, and other manufacturing problems.

[0007] The conventional packaging machine also has a large vertical height. As shown in FIG. 1, cartons are picked up at Station 3 at a raised position and lowered onto the bottles at Station 6. Because the carton pickup and carton loading steps are performed along a line, the height of the carousel must be sufficient to accommodate the highest point of the stroke (i.e., before pickup), and the lowest point of the stroke (i.e., at loading).

SUMMARY OF THE INVENTION

[0008] Briefly described, the present invention generally is directed to a high speed packaging system for packaging various types of articles in a variety of different configurations of containers or cartons. The articles, such as bottles, cans, or the like, generally will be fed into and through the packaging system of the present invention along a path of travel on an infeed conveyor on an upstream side of the packaging system. The articles can be separated in one or more lanes of products, in side by side or in staggered configurations.

[0009] As the articles are fed into the upstream or receiving end of the packaging system, the articles pass through a selector station for selecting and grouping the articles into groups. As the articles are separated into their packaging groups, the groups of articles are further transferred to a packaging line along which the groups of articles are placed into containers. The packaging line may generally extend along a path substantially parallel to the path of travel of the articles along the infeed conveyor, although other orientations are possible.

[0010] A carton loading carousel will be positioned adjacent to and extend parallel to the packaging line, and includes a series of carton carriers moving thereabout. In accordance with one aspect of the present invention, the carriers are moved about the carousel from a carton pickup point along a first side of the carousel, and subsequently moved into a loading position along a second side of the carousel. The carriers can be moved along a cam track that extends about the periphery of the carousel to raise and lower the cartons as the cartons are moved between pickup and loading positions. At this loading position, the cartons are engaged with a selected group of articles moving along the packaging line. In one embodiment, the cartons can be lowered as they approach their loading position, with the cartons being moved forwardly and downwardly over the selected group of articles to load the articles within the cartons. Alternatively, in another embodiment, the cartons can be moved from a lowered position passing below an article infeed line for the articles, to an elevated loading position. As the cartons are moved upwardly beneath a selected group of articles, the articles are loaded into one or more compartments of the cartons from above the cartons.

[0011] The cartons may be provided by a carton infeed system and opened in a carton opener. The opening and pickup of the cartons may be accomplished along an initial portion of a carton loading path that is substantially parallel to but extending opposite or spaced from the packaging line so that two sides of the loading carousel are utilized.

[0012] According to one aspect of the present invention, use of two sides of the loading carousel allows the packaging system to open and load cartons with groups of articles in a significantly reduced length, space, and/or footprint, without reducing packaging speed. Also, because the pickup stroke can occur on one side of the carousel, and the loading stroke can occur on the opposite side, the loading carousel can be significantly shorter in height than conventional carousels. In addition, the relatively small size of the loading carousel reduces the mass of moving parts in the carousel, meaning a smaller inertia during operation.

[0013] Various objects, features and advantages of the present invention will become apparent to those skilled in the art upon reading the following detailed description and taken in conjunction with the accompanying drawings.

BRIEF DESCRIPTION OF DRAWINGS

[0014] **FIG. 1** is a perspective view of a conventional prior art article packaging system.

[0015] **FIG. 2** is a top plan schematic view of a packaging system according to an embodiment of the present invention.

- [0016] FIG. 3 is a perspective partial schematic view of the packaging system.
- [0017] FIG. 4A is a perspective partial schematic view of the packaging system.
- [0018] FIG. 4B is a partial perspective view showing the operation of a loading carousel according to an embodiment of the present invention.
- [0019] FIG. 5 is a perspective partial schematic view of the packaging system illustrating a carton infeed system.
- [0020] FIG. 6 is a side elevational partial schematic view of the packaging system.
- [0021] FIG. 7 is a partial perspective view showing the operation of the loading carousel.
- [0022] FIG. 8 is a perspective view of an additional embodiment of a packaging system according to the present invention.
- [0023] FIG. 9 is a side elevational view showing the loading of products into basket type packages according to the embodiment of FIG. 8.
- [0024] FIG. 10 is an end view of the upstream or inlet end of the packaging system of FIG. 8.
- [0025] FIG. 11 is an end view of the downstream or outlet end of the packaging system of FIG. 8.

DETAILED DESCRIPTION

- [0026] FIGS. 2-7 illustrate a high speed packaging system 10 according to a first embodiment of the present invention. In this embodiment, the packaging system 10

generally is designed to provide a substantially continuous motion system for high speed packaging of various types of articles in a variety of configurations of containers, including, for example, six-pack, four-pack, or eight-pack cartons, as well as smaller or larger configurations. For the purposes of illustration and simplicity of description, the packaging system embodiment discussed in detail below is described as loading bottles **B** into cartons **C** to form packages **P**.

[0027] Referring to **FIG. 2**, the packaging system **10** has a first, upstream or inlet end **12** and a second, downstream or outlet end **13**. The packaging system **10** comprises the following general components: a carton infeed system **90** having an opener **93** for providing opened cartons **C** in the system **10**, a loading carousel **60** for loading bottles **B** in the cartons **C**, an article transport or infeed conveyor **16** for providing bottles **B** in the system **10**, a selector station **30** for metering the flow of bottles **B** into the loading carousel **60**, as indicated by arrow **42**, a packaging line **45** for moving the cartons **C** and bottles **B** during loading, a closing mechanism **86** for engaging and closing the bottoms of the cartons **C**, and a outlet mechanism **110** for forwarding the packs **P** down the conveyor line for further handling and/or packaging. The packaging system **10** generally will also include a frame (not shown) or support housing. The frame can include, for example, one or more bays or doors to enable access to the packaging machine **10**. The outlet mechanism **110** can be, for example, a two-way divider, as shown in **FIG. 2**.

[0028] As generally shown in **FIG. 2**, the loading carousel **60** has a first side **8** and a second side **9**, both of which are used for opening and loading of cartons **C**. Using two sides **8, 9** of the carousel **60** for opening and loading has the effect of reducing

both the required stroke and the number of flights or carriers required for opening and loading the cartons **C**. The required stroke and number of flights can be reduced, for example, by about half, when compared to conventional packaging machines having similar output capabilities. The reduction of the number of flights or carriers required accordingly reduces the plan area or footprint of the packaging system **10**. This significant reduction in footprint in turn conserves valuable shop space. The reduction in stroke reduces the vertical height of the packaging system **10**, in particular the height of the loading carousel **60**.

[0029] As shown in **FIG. 2**, the carton infeed system **90** having the opener **93** is located on the first side **8** of the loading carousel **60**. The article transport conveyor **16**, the selector station **30**, and the packaging line **45** are located on the second side **9** of the loading carousel **60**. The structure and operation of the packaging system **10** are discussed in detail below with reference to **FIGS. 2-7**.

[0030] Referring to **FIGS. 3, 4A and 4B**, the article transport conveyor **16** provides a supply of bottles **B** to the loading carousel **60**. The article transport conveyor **16** generally is positioned at the upstream end **12** of the packaging system **10** for receiving the bottles **B** and moving them along an infeed path of travel indicated by arrow **17**. The article transport conveyor **16** generally may be a belt, chain or other conventional type of conveyor having an upper surface **18** along which the bottles **B** are moved. The article transport conveyor **16** can include, for example, dividers **19** for separating the bottles **B** into one or more lanes **21, 22**. The article transport conveyor **16** further includes a first or proximal end **23** where the bottles **B** are received from an upstream production line (not shown), and a second or distal end **24**

where the bottles **B** are engaged and transferred from the article transport conveyor 16 by the selector station 30.

[0031] Referring to **FIGS. 4A** and **4B**, the selector station 30 meters the flow of bottles **B** into the loading carousel 60 by ordering the bottles **B** into groups that are conveyed along the packaging line 45. The selector station 30 generally may include a series of metering or star wheels 31 having product receiving recesses 32 formed thereabout. The star wheels 31 engage and meter the flow of bottles **B** moving along the article transport conveyor 16, and redirect the lanes 21, 22 of bottles **B** toward a pair of selectors 33.

[0032] The selectors 33 may be conventional and are schematically illustrated in **FIGS. 3, 4A** and **4B**. The selectors 33 may generally include upper and lower support plates and a series of pairs or sets of selector arms mounted therebetween. Each selector arm may include an article engaging or separating plate mounted at a front or proximal end thereof, with each separating plate having a series of teeth defining a series of recesses therebetween. The selector arms can be moveable radially from a retracted, initial position for engaging and moving a series of bottles **B**, e.g., 2, 3, 4, etc., depending upon how many bottles **B** are metered to carousel 60, as the selector arms are rotated with the rotation of the selectors 33. The selectors 33 can be configured to place bottles **B** into any desired configuration group, and typically will move at a different rate as they engage their respective groups of bottles **B** so as to create a separation or stagger between the groups of bottles to form a desired package grouping configuration. In the illustrated embodiment, the bottle groups have a 2x3 configuration.

[0033] Referring to **FIGS. 5 and 6**, the carton infeed system **90** and the opener **93** provide a supply of cartons to the loading carousel **60**. Cartons **C** are initially fed into the packaging system **10** at the carton infeed system **90**. The cartons **C** can be infeed at a variety of points or locations, for example. The infeed system **90** can include, for example, a carton infeed conveyor **97** that provides an initial supply of cartons **C**, and a carton transport conveyor **96** that transports the cartons **C** through the opener **93** and along the first side **8** of the carousel **60**. The carton infeed system **90** may be positioned slightly downstream from the loading carousel **60** and opposite to the closing mechanism **86**, and provides a substantially continuous flow or line of opened cartons **C** to the loading carousel **60**. The carton infeed system **90** may be positioned in a vertically raised arrangement above the outlet mechanism **110**.

[0034] The opener **93** can include a carton opening apparatus or mechanism such as disclosed in U.S. Patent No. 6,240,707, the entire disclosure of which is incorporated herein by reference. In general, the opener **93** can include a frame **94** having a guide slot or track. A series of carton opening assemblies **98** are transported about the frame **94**, moving between a carton pickup or engaging position **99** and a discharge position **101**, in which the opened cartons **C** are released and further conveyed along the carton transport conveyor **96**. The opening assemblies **98** are conveyed about the opener **93** for picking up flat folded cartons **C** and opening the cartons to an opened position before release at the discharge position **101**. The opener **93** also can include an adjustable internal opener cam that generally reduces the maximum height of the cartons **C**, which reduces the opener head mast/radius. Further, an adjustable internal opener cam can be provided for enabling opening of varying size cartons.

- [0035] The loading carousel **60** loads the bottles **B** supplied by the selector station **30** into the opened cartons **C** provided by the opener **93**. Two sides **8, 9** of the loading carousel **60** are utilized in the packaging system **10**. The structure and operation of the loading carousel **60** are discussed in detail below.
- [0036] Referring to **FIGS. 3, 4A and 4B**, the loading carousel **60** is mounted adjacent to and extends along the upstream or inlet end **49** of the packaging line **45**. The loading carousel **60** includes upstream and downstream rotating supports **62** and **63**, respectively, that are engaged with upper and lower chains or belts **64** and **66**, respectively, that are moved about a substantially elliptical path by the rotation of the upstream and downstream supports **62** and **63**. Rotation can be effected by motors or other drive mechanisms, for example. The rotating supports **62** and **63** may be sprockets having teeth that engage the chains **64, 66**, respectively, for example. The rotating supports **62, 63** may alternatively be gear or belt-driven. The carton transport conveyor **96** on the first side **8** of the loading carousel **60** may be spaced from and extend parallel to the packaging line **45** on the second side **9** of the carousel **60**. The second side **9** of the loading carousel **60** may extend from a point slightly upstream from the inlet end **49** of the packaging line **45** approximately to the discharge end **51** of the packaging line **45**.
- [0037] **FIGS. 6 and 7** illustrate the first side **8** of the loading carousel **60**, where the carousel **60** receives and picks up the opened cartons **C** from the carton transport conveyor **96**. The loading carousel **60** includes a series of carton carriers **71** that are carried along an elliptical path in the direction of arrows **72** (**FIG. 3**) by the rotation of the loading carousel **60**. The rotation conveys the carriers **71** to first, lowered pickup

position 73, where the carriers 71 pick up the cartons C. The carriers 71 subsequently transport the cartons C to a second, lowered loading or article receiving position 74 (FIG. 4B) along the second side 9 of the carousel 60, where the cartons C are placed about groups of bottles B. Each of the carriers 71 generally will include a spaced pair of arms 76 and 77 extending vertically downwardly from a laterally extending support plate 78. Each support plate 78 is attached to and is carried by a pair of vertically extending support rods 79 so as to transport the carriers 71 about the periphery of the loading carousel 60, while also allowing for vertical translation of the carriers 71. Each support plate 78 may be connected to a block 81, which may be connected to one of each pair of the support rods 79 by an angled plate 82. The carriers 71 also are typically operated without a back wall to allow better carton side guides at the pick up position 73, and can be adjusted by a screw, or otherwise, for example, to accommodate various container sizes.

[0038] A cam follower or guide 83 may be attached to each of the blocks 81 or to the support plates 78. Each cam follower 83 will generally engage and move along a cam track 84 in the loading carousel 60 as the carriers 71 are moved about the carousel 60. The cam track 84 generally has a first, pickup cam profile or side 84A extending along the first side 8 of the carousel 60, and a second or loading side profile 84B extending along the second side 9 of the carousel 60. As a result, the carriers 71 are moved between the lowered and raised positions shown in FIGS. 4B and 7, respectively, during the transport of the cartons C from the pickup position 73 (FIG. 7) to the article loading or engaging position 74 (FIG. 4B). As the cartons C are moved along their path of travel from the pickup position 73 to the article loading

position 74, the cartons C will be raised to an intermediate, raised position 75 (FIG. 4B).

[0039] Referring to FIG. 4A, the cartons C are then conveyed into alignment with the bottle groups being formed therebeneath along the packaging line 45, and then lowered in timed relation to the movement of the groups of bottles B along the packaging line 45 so that each carton C is matched with a group of bottles B and thereafter progressively lowered down over the bottles at the article loading position 74. The cartons C may have channels, cavities or other compartments in which the bottles B are received, as illustrated in FIG. 4B. A plow 80 may be included to manipulate base flaps of the cartons C, if present, and may function to hold the flaps outwardly so that the cartons C are more easily lowered over the bottles B. For the purposes of clarity of illustration, the opened bottom flaps of the bottles B are not shown in the Figures.

[0040] Referring to FIG. 4B, after the bottles B are received in the channels of the cartons C, the arms 76 and 77 of the carriers 71 can be raised out of engagement with the loaded cartons C as the cartons C are engaged by the closing mechanism 86 (FIG. 3). The closing mechanism 86 may be conventional in operation and can include a flap tucking mechanism that engages and tucks locking tabs or flaps along the bottom surfaces of the cartons into a locked arrangement. Alternatively, the closing mechanism 86 can include a folder/gluer mechanism that applies a bead of glue between the bottom flaps of the cartons and thereafter presses the bottom flaps into engagement with one another to seal them together. The finished, closed cartons C are then fed further downstream for transfer to the discharge or outlet mechanism 110.

- [0041] As illustrated in FIG. 4A, the packaging line 45 extends in the direction of arrow 46, and may be spaced from and substantially parallel to the path of travel 17 of the flow of products on the infeed conveyor 16. The packaging line 45 may include, for example, a conveyor belt 47, although other, similar types of conveying mechanisms also can be used, for transport of the groups of bottles B. The conveyor belt 47 moves about a substantially elliptical path between the upstream end 49 and the downstream end 51, at which point the loaded packages P are delivered to the outlet mechanism 110.
- [0042] The system 10 detailed herein can utilize a variety of drives, including servo-motors, stepper motors, AC or DC motors, pneumatic or hydraulic drives that operate, or are connected to, the following operative elements: the loading carousel, the opener, the closing mechanism, the starwheels, the selector station, the container infeed, etc. Other units can be mechanically or servo driven or can slave off of existing drives (e.g., carton feeding could drive off of the carousel drive).
- [0043] The packaging system 10 described herein can utilize a standard two lane infeed conveyor arrangement as illustrated. The system 10 layout can also be widened with bottles B infeeding alongside the carton feed and around the outside of the carousel 60 head shaft. The starwheels 31 and selectors 33 may be of a design and construction as found in the Autoflex 1500 as manufactured by Graphic Packaging International, Inc.
- [0044] FIGS. 8 -11 illustrate a second embodiment of the packaging system 100 according to the principles of the present invention. As discussed above with respect to the embodiment of FIGS. 2 - 7, the packaging system 100 (FIGS. 8 and 11) of the

present embodiment will include a loading carousel **110** for loading articles or products, such as bottles **B** or other similar products, into cartons **C**, here illustrated as basket-type cartons or containers, each having a series of compartments defined therein. As illustrated in **FIGS. 8 and 9**, the articles to be packaged, such as bottles **B**, are conveyed in one or more lanes or lines of articles along an article infeed path into the packaging system **100** along an article infeed conveyor **111** in the direction of arrow **112**. In this embodiment, the article infeed conveyor **111** typically enters the packaging system **100** at the upstream end **113** of the packaging system, generally at an elevated position with respect to the loading carousel **110** and terminating at a discharge point **114**.

[0045] The loading carousel **110** includes a substantially elliptically shaped frame **116** having a first side **117** along which the open carton **C** are engaged and picked up at an initial or pickup point **118** (**FIG. 8**). The cartons thereafter are conveyed about the loading carousel along a loading path in the direction of arrow **119** under the article infeed conveyor **111**, to a loading point **120** along a second side **121** of the loading carousel. The loading carousel **110** further includes a series of carriers **122** for conveying cartons about their loading path indicated by arrow **119**. As illustrated in **FIGS. 8 – 10**, each of the carriers **122** generally includes a base **123** that is slideably mounted on a pair of vertically extending support rods **124** that are attached to the frame **116** of the loading carousel so as to be rotated therewith to move the carriers about the loading path **119**.

[0046] Container or carton supports **126** (**FIGS. 9 – 10**) are mounted on the base of each carrier **122**, and are typically vertically spaced from their base **123** by upstanding

plates or brackets 127. Each of the container supports generally is a U- or C-shaped member having front and rear walls 128 and 129, respectively, with a longitudinally extending section or portion 131 therebetween. The container supports 126 further are spaced apart, as indicated in FIGS. 10, so as to define a space or passage 132 therebetween. The cartons C are received from a carton opener 135 (FIGS. 8, 9) positioned along the first side 117 of the loading carousel, upstream from the carton pickup point 118, as the carriers are moved along an initial or upstream portion of the carton loading path 119. The carriers receive the opened cartons with the front and rear corners of the cartons engaging the corners between the front and rear walls and intermediate sections of each of the container supports, and with the outer side edges of the cartons being supported by the intermediate sections 131 (FIG. 9) of each of the container supports 126.

[0047] The carton opener 135 generally will have a substantially similar construction to the carton opener as described above with respect to the embodiment of FIGS. 2 – 7, generally including a frame 136 (FIG. 8), about which a series of carton opening assemblies 137 are conveyed in the direction of arrows 138. The carton opening assemblies 137 will engage and pick flat folded cartons C from a magazine 139, or similar supply of cartons, progressively opening the cartons before releasing the cartons C onto the container supports 126 of each of the carriers 122 at the pickup point 118 as indicated in FIGS. 8 and 10.

[0048] As generally illustrated in FIG. 9, a cam track 141 is mounted within the frame 116 of the loading carousel 110, extending along a substantially elliptical path within the confines of the loading carousel frame. A cam follower or roller 142 is

attached to a rear side surface of the base 123 of each of the carriers 122 and engages and rolls along the cam track as the carriers are transported around the loading carousel 110 in the direction of arrows 119. As a result, as the cam followers roll along the cam track 141, the carriers are moved upwardly and downwardly in the direction of arrows 143 and 143' as indicated in FIG. 9. Such movement causes the carriers, and thus the cartons carried thereby, to be raised and lowered as the carriers are transported about the loading carousel 110 along the initial or upstream, intermediate, and downstream portions of the loading path 119 of the cartons. As indicated in FIG. 8, the carriers accordingly are transported from a raised configuration at the pickup point 118 wherein the opened cartons C are loaded into each of the carriers 122, and are lowered as the cartons are conveyed along the intermediate portion of the loading path 119, so as to pass beneath the article infeed conveyor 111. Thereafter, the cartons will be raised to an elevated position as they move along the downstream portion of their loading path, coming up from beneath the bottles B at the loading point 120 for loading the bottles into the cartons, as indicated in FIGS. 8 and 11.

[0049] As generally illustrated in FIGS. 9 and 10, a dead plate 146 can be mounted at the discharge end 114 of the article infeed conveyor 111, extending longitudinally therefrom between the discharge end of the article infeed conveyor 111 and the loading point 120 of the carriers 122. The dead plate typically will be a substantially flat, longitudinally extending plate having a smooth upper surface 147 along which the bottles are received and moved for loading into their respective cartons.

[0050] A selector station 150 (FIGS. 8 and 9) is mounted along the dead plate 146 for engaging and grouping the bottles into selected groups G, such as in six-pack configurations as illustrated in FIGS. 8 and 9, or in other configurations or arrangements as needed or desired. The selector station 150 can include a series of selectors such as selector wedges or blocks 151 arranged in groups or series, such as in groups of 1 – 3 selector wedges moving along both sides of the dead plate. The selector wedges 151 generally will be mounted on and conveyed into engagement with the bottles B by conveyors 152 and 153 extending on each side of the dead plate and article infeed path. Each of the selector wedges 151 (FIG. 11) typically can include a substantially arcuate-shaped upper portion or base 154, defining a recess in which one of the bottles will be received, and a downwardly extending guide or finger portion 156. The guides 156 are each adapted to engage and be received within a compartment of a carton C as the cartons are raised toward bottles at the loading point 144.

[0051] As indicated in FIGS. 8 – 10, the selector wedges generally will engage a series of products, i.e., 1 – 3 bottles, so as to create a product group G, such as a six-pack of bottles, that are separated and moved forwardly along the dead plate and away from the article infeed conveyor, toward the loading point 120. At the loading point, the bottles will be lowered or dropped into the compartments of their respective cartons C as the cartons are raised toward the bottles by the upward movement of the cam followers 142 of the carriers 122 along their cam track 141, as indicated in FIGS. 9 and 11. The fingers or guide portions 156 of each of the selector wedges 151 are received within the compartments of the cartons and tend to guide the bottles into

their respective compartments of the cartons to control the feeding of the bottles therein to reduce or minimize mis-feeding and/or the shock or jarring forces translated to the carriers and support rods from the bottles dropping into the cartons.

[0052] As illustrated in FIG. 9, after the bottles have been received within the compartments of their associated cartons, the cartons thereafter are progressively lowered as the cam followers 142 of the carriers 122 continue along the cam track 141 in the direction of arrows 143. As the carriers are moved forwardly downwardly, the cartons are deposited onto a takeoff conveyor 160 (FIGS. 8 and 9). The takeoff conveyor generally comprises a narrow conveyor belt 161 of a size adapted to be received within the passage 132 defined between the container supports 126 of each of the carriers. As indicated in FIG. 9, the carriers deposit their cartons C onto the conveyor belt 161 of the takeoff conveyor 160, as the carriers are moved forwardly and are lowered by the continued downward movement of their cam followers 142 along the cam track 141. The carriers are lowered to an elevation below the elevation of the takeoff conveyor 160, so that the carriers can be turned and pass therebeneath without interference with the takeoff conveyor 160 or the cartons contained thereon.

[0053] Thereafter, as indicated in FIG. 8, the loaded cartons C are transferred to a discharge conveyor 162, with the loaded cartons typically being divided into two or more lines or paths. The discharge conveyor 162 will thereafter discharge the loaded cartons away from the packaging system 100 to a downstream station such as a case packer or other station for collecting and packaging the loaded packages or cartons for storage and/or transport.

[0054] The loading carousels illustrated in the Figures have a two-sided configuration generally utilizing two spaced, rotating supports. An alternative loading carousel can have, for example, three sides formed by three rotating supports. The functions of pickup and loading can be performed, for example, along two or more of the three sides of the carousel. Another alternative loading carousel could be rectangular in shape, with the functions of pickup and loading of the cartons performed along two or more of the four sides of the carousel. In addition, although two sides of the packaging system of the present invention could be tended by an operator, the packaging system can account for any missed cartons in the loading function on the first side of the loading carousel by a single operator positioned along the second side of the packaging system.

[0055] The present invention further is suitable for loading a variety of articles in a variety of containers. Suitable articles include, for example, bottles as shown in the drawings, cans or similar articles. Suitable containers can include, for example, paperboard cartons and basket type containers or carriers. The containers used with the packaging system can include, for example, a glued base, locking tabs, and/or other types of carton closures. The packaging system further can utilize existing style basket containers or can operate with alternative base hole patterns for engagement by a transport conveyor. The base crease hole pattern of the cartons C can be configured or created with an existing Graphic Packaging International, Inc. "A-B Ruff-Rider" die, or a similar die, with base crease holes added. Two pairs of base crease holes can be added, one for use by the container infeed and one for use by the carousel. The two pairs of base crease holes provide a larger transfer target and eliminate lug/finger

interference, as well as allow the possibility of repitching the input or carton transport conveyor to between a 12.5" paper feed and a 10" pitch carousel for higher packaging per minute at lower linear speeds. The packaging system further generally can allow for a surge requirement of up to at least 250 packages formed per minute.

[0056] It will be understood by those skilled in the art that while the invention has been discussed above with reference to preferred embodiments, various changes, modifications and additions can be made thereto without departing from the spirit and scope of the invention as set forth in the following claims.

WHAT IS CLAIMED IS:

1. A packaging system for packaging articles into containers, comprising:
 - a loading carousel having a first side along which the containers are received and opened and a second side along which opened containers are conveyed for loading;
 - an article infeed system positioned to feed articles to the loading carousel along a path adjacent the second side of the loading carousel; and
 - a discharge conveyor disposed along the second side of the loading carousel;wherein the loading carousel transports the containers from a pickup on the first side of the loading carousel to a loading position along the second side of the loading carousel, with the containers being moved upwardly from below the articles for receiving the articles therein, after which loaded containers are received on and conveyed away from the loading carousel by the discharge conveyor.
2. The packaging system of claim 1, and further comprising a container infeed system having at least one container infeed conveyor and a container opener.
3. The packaging system of claim 1, wherein the article infeed system comprises an article conveyor having at least one lane along which the articles are conveyed.

4. The packaging system of claim 1, further comprising a selector station positioned along the second side of the loading carousel and including a series of selectors for grouping articles from the article infeed system into article groups.

5. The packaging system of claim 1, wherein the loading carousel comprises:
 - a frame; and
 - a plurality of carriers moveable along a loading path about the frame to carry the opened containers from a pickup position along the first side of the loading carousel, to a loading position along the second side of the loading carousel where the containers are moved upwardly to their loading position for receiving the articles therein.

6. The packaging system of claim 5, wherein the carriers are conveyed along a cam track about the loading carousel, the cam track having a first elevated portion along the first side of the loading carousel at which the carriers are in a position for receiving the opened containers, a lowered portion extending below the article infeed system, and a second elevated portion along the second side of the loading carousel, wherein the carriers are raised to their loading position from beneath the articles.

7. The packaging system of claim 1 and further comprising a container infeed system providing cartons having individual compartments, and wherein the

articles conveyed along the article infeed system each are sized to be received in an individual compartment of the cartons.

8. The packaging system of claim 7 and further comprising a series of product guides adapted to be received within the compartments of the cartons for guiding articles into the compartments of the cartons.
9. The packaging system of claim 1 and wherein the loading carousel comprises a frame, a cam track extending about the frame, and a plurality of carriers moveable along the cam track and about the frame between a pickup position for receiving a container and a loading position at which the containers are loaded with articles.
10. The packaging system of claim 9 and wherein each of the carriers comprises a base mounted on a pair of support rods attached to the rotating frame of the carousel, a cam follower mounted to the base and adapted to engage and move along the cam track for causing the carriers to be raised and lowered, and a pair of spaced container supports adapted to engage and support the containers along side edges and corners thereof.
11. A method of packaging articles into a series of cartons, comprising:
conveying the articles along an article infeed path;

conveying the cartons about a first side of a loading carousel along an initial portion of a loading path in a direction substantially parallel to and opposite from the article infeed path;

picking up each of the cartons with a carrier moving along the loading path;

as the cartons are moved along the initial portion of their loading path, opening the cartons to a configuration for receiving the articles therein;

moving the cartons to a lowered position below the article infeed path of the articles after pickup;

redirecting and conveying the opened cartons about a second side of the loading carousel and along a downstream portion of their loading path in a direction substantially parallel to and into alignment with the articles moving along the article infeed path;

as the cartons are moved along the downstream portion of their loading path, raising the cartons to a loading position below the articles; and

lowering the articles into the cartons.

12. The method of claim 11, further comprising grouping the articles into article groups before packaging the articles within the cartons.

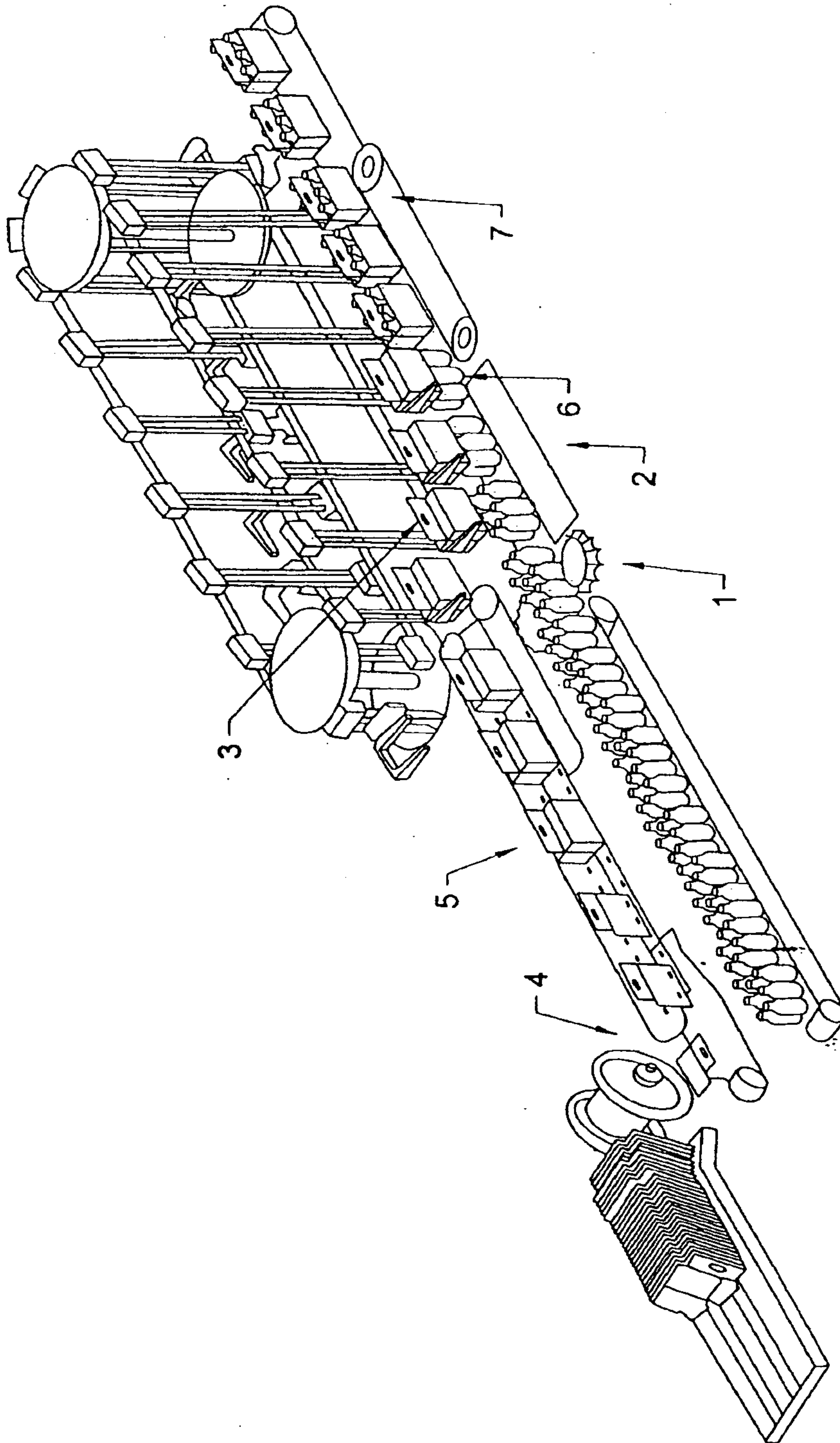

Fig. 1
(PRIOR ART)

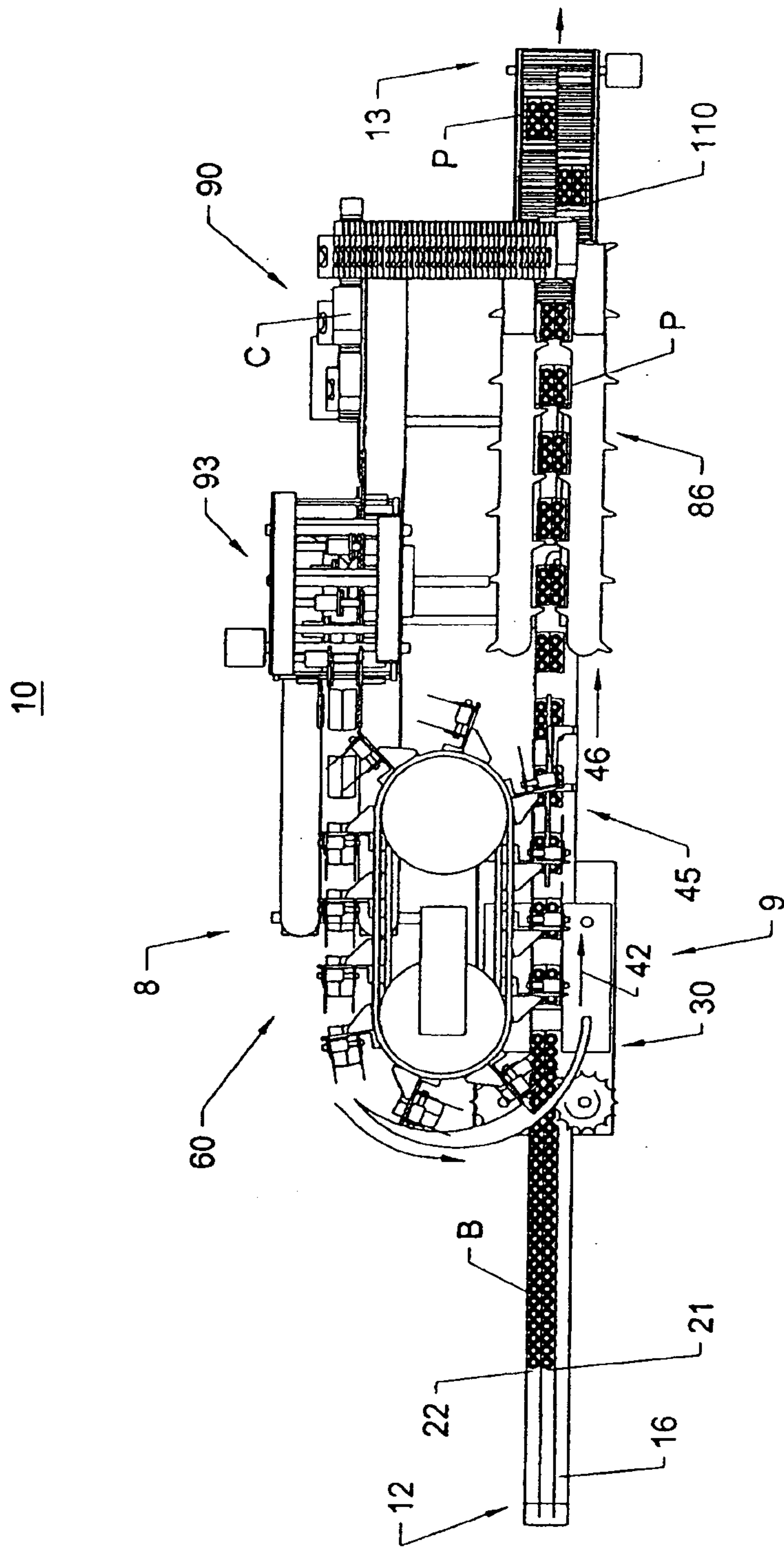

Fig. 2

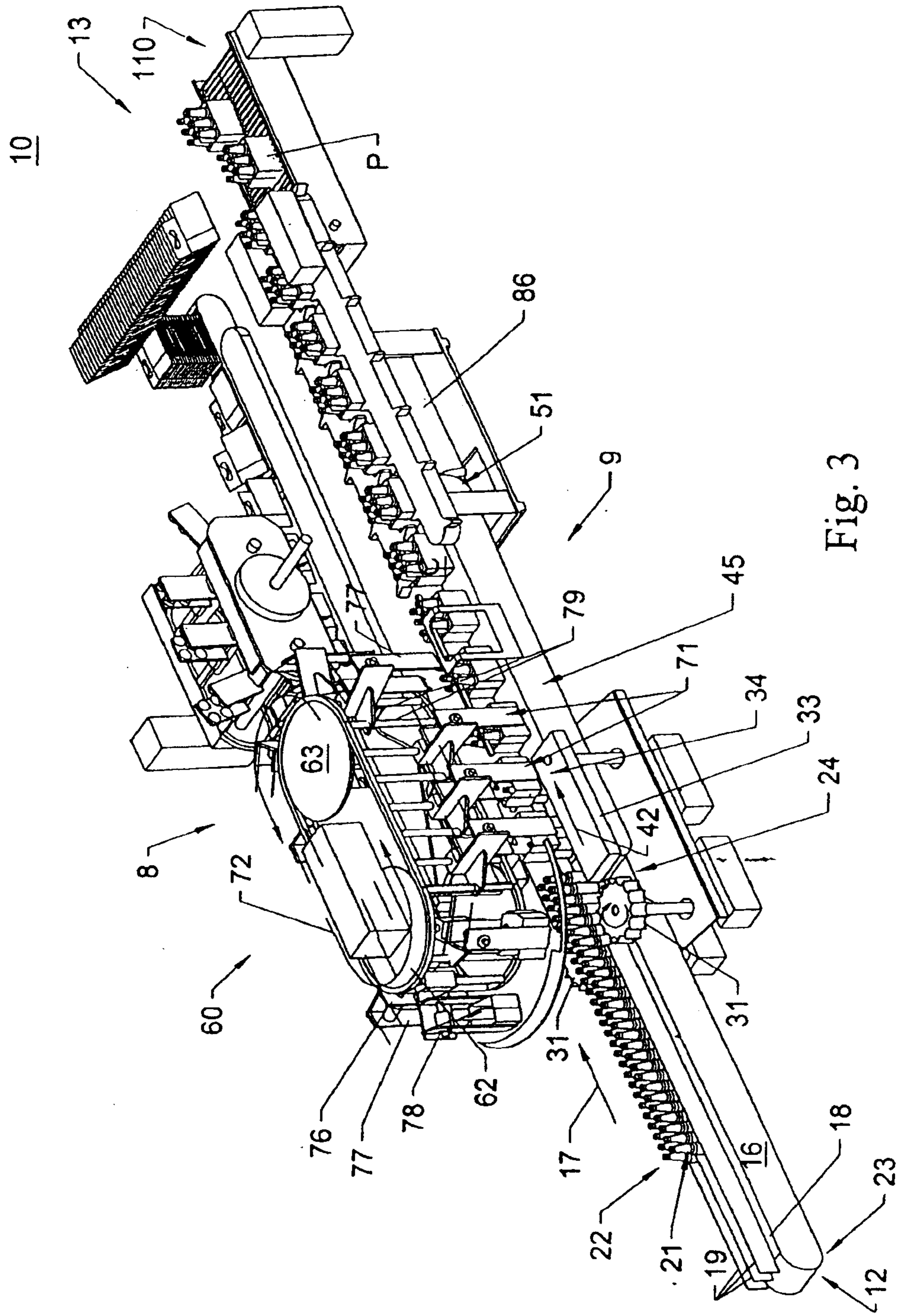

Fig. 3

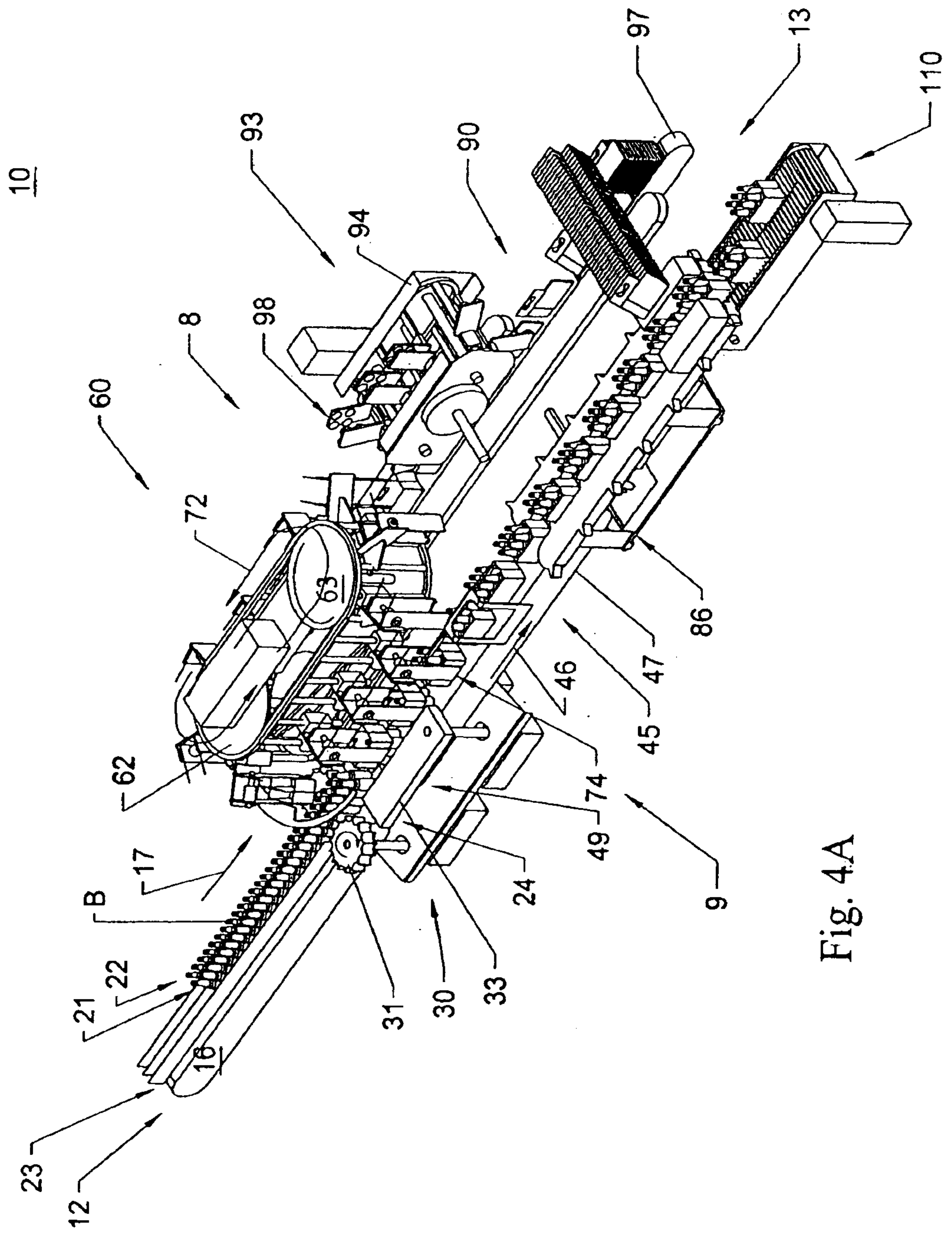

Fig. 4A

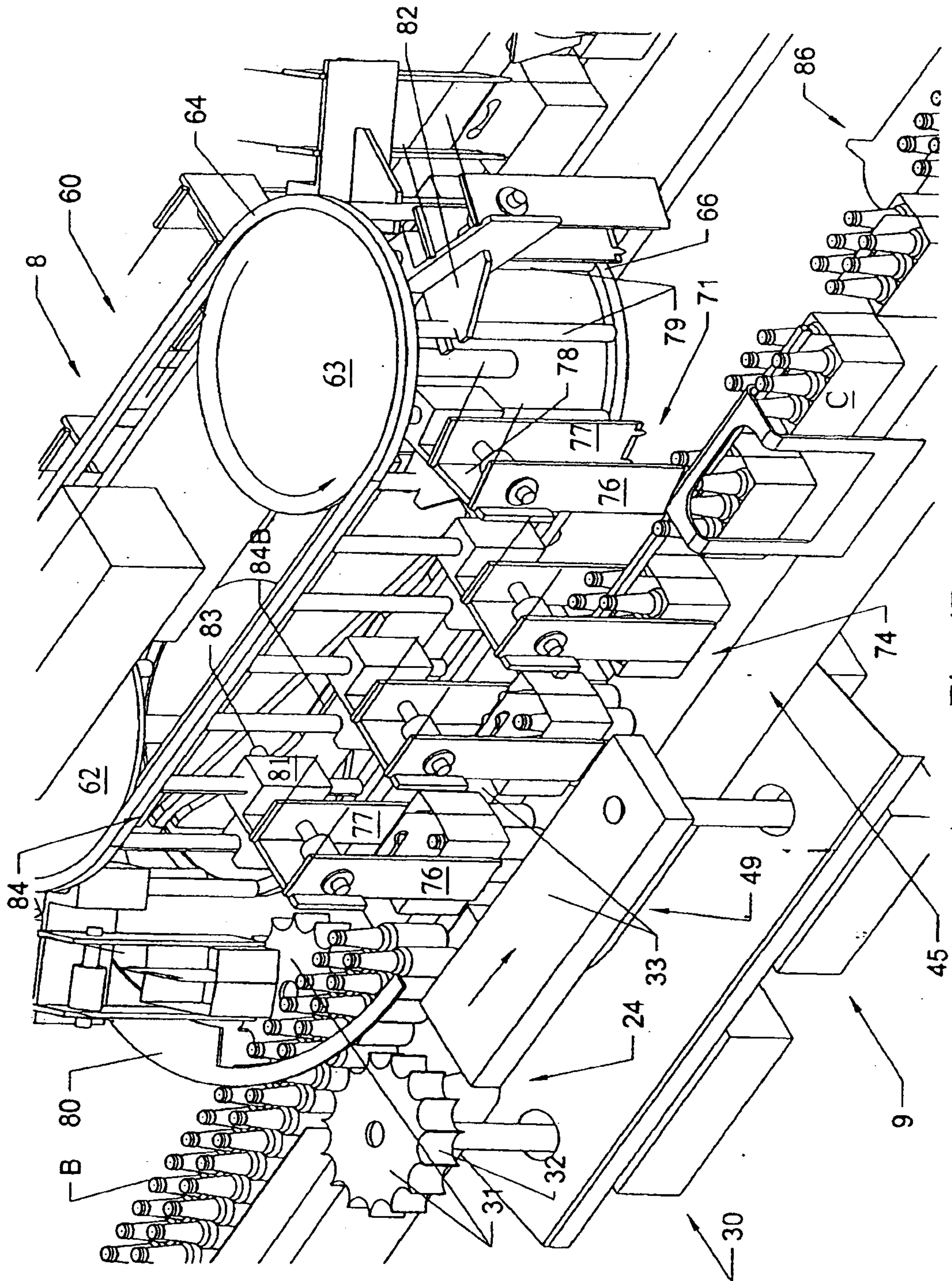

Fig. 4B

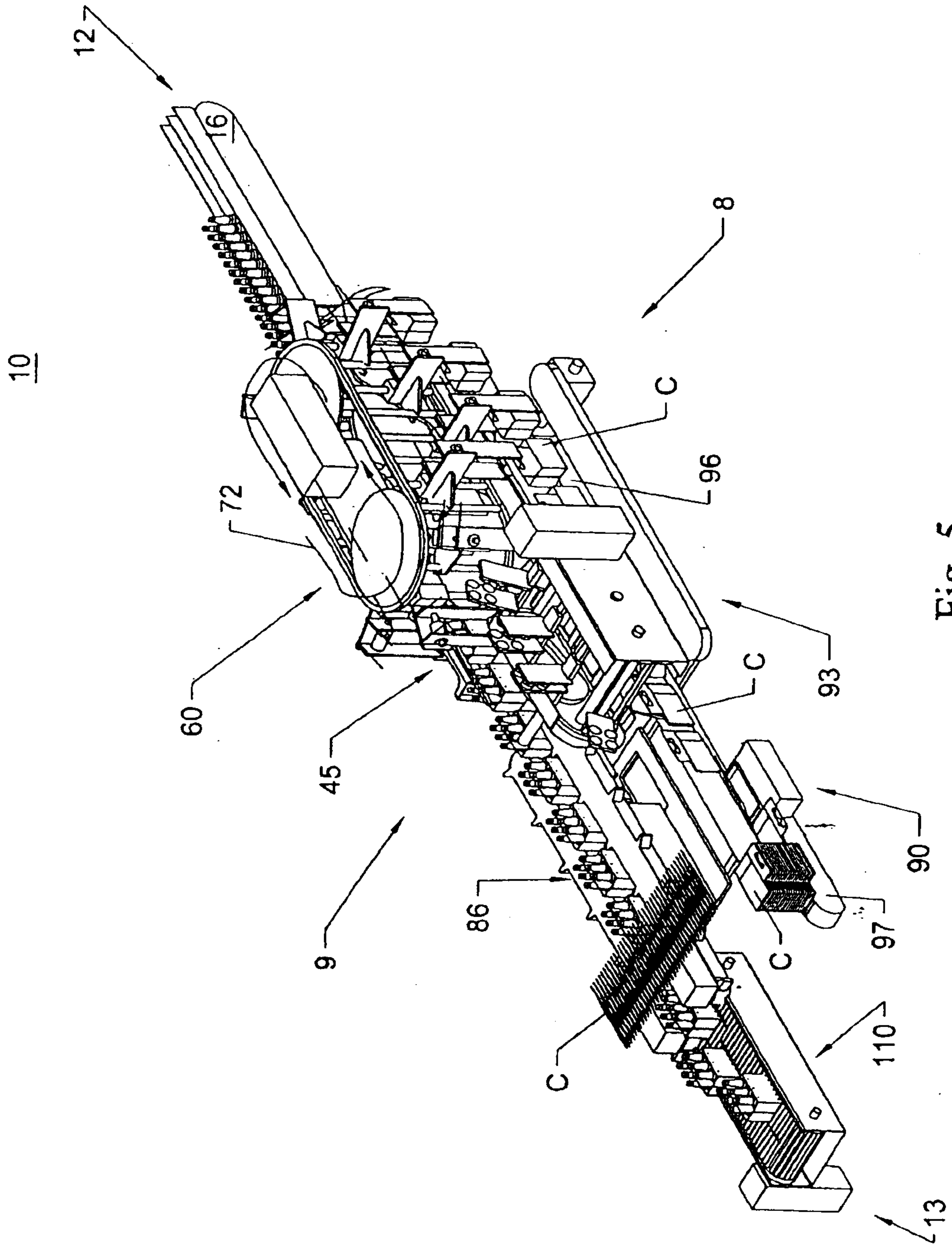

Fig. 5

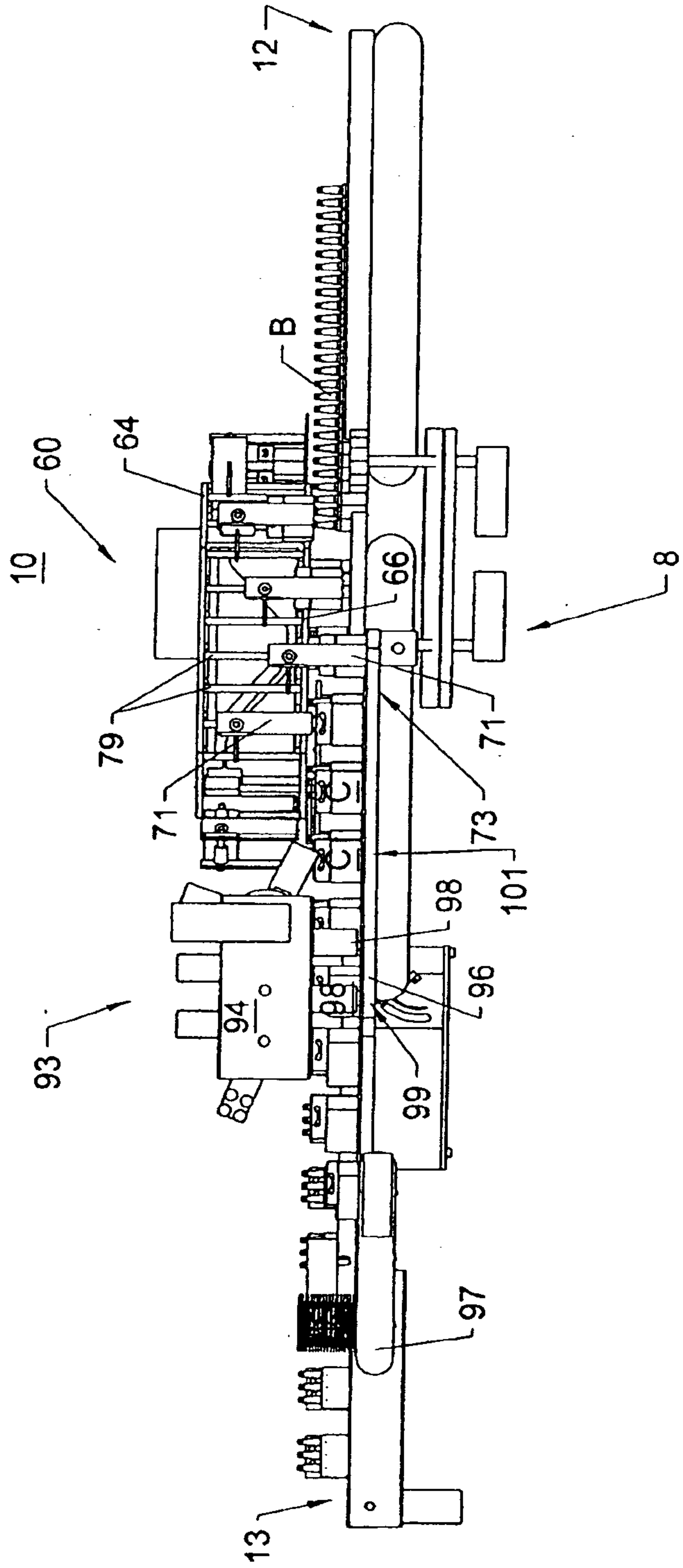

Fig. 6

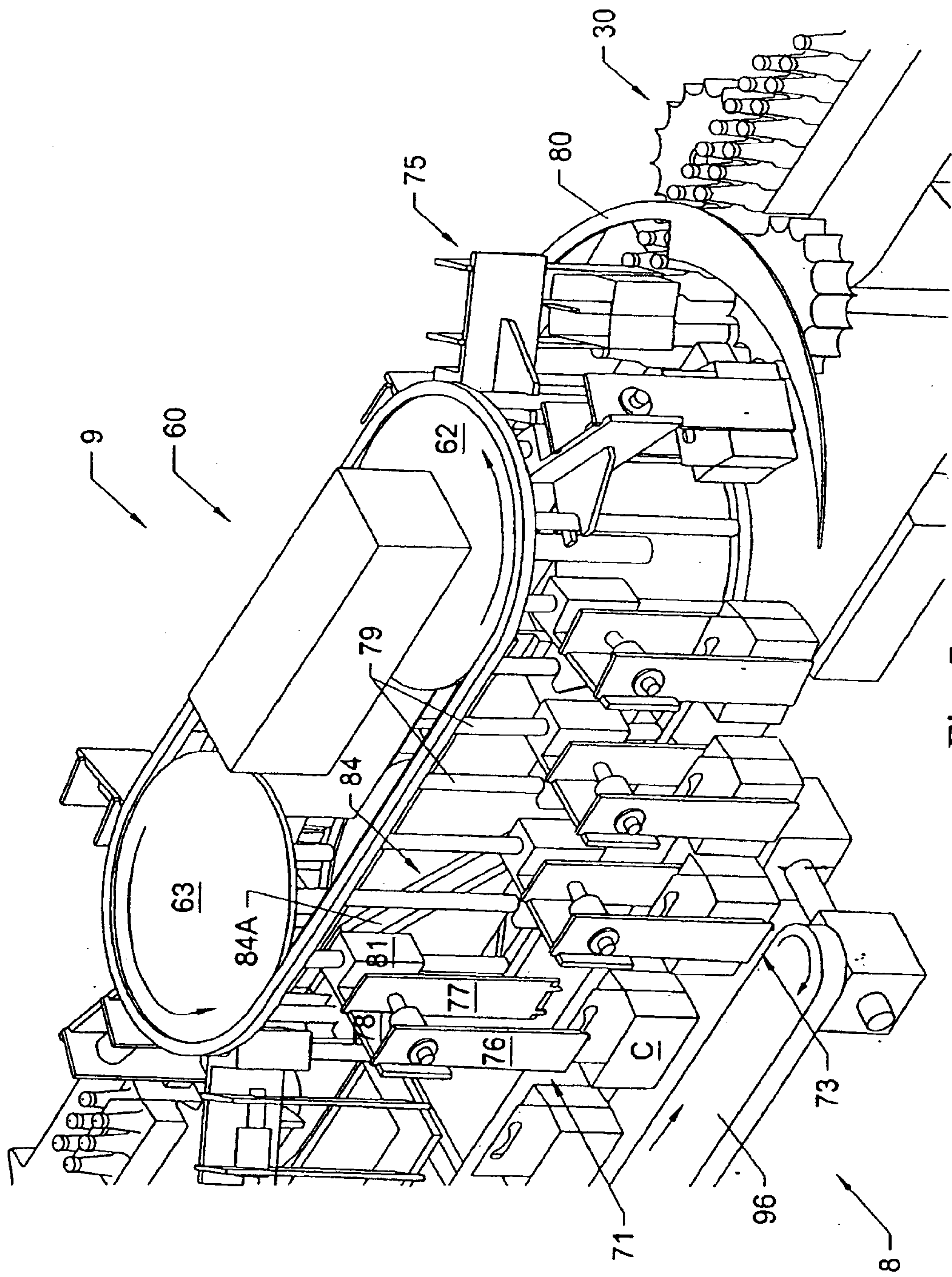

Fig. 7

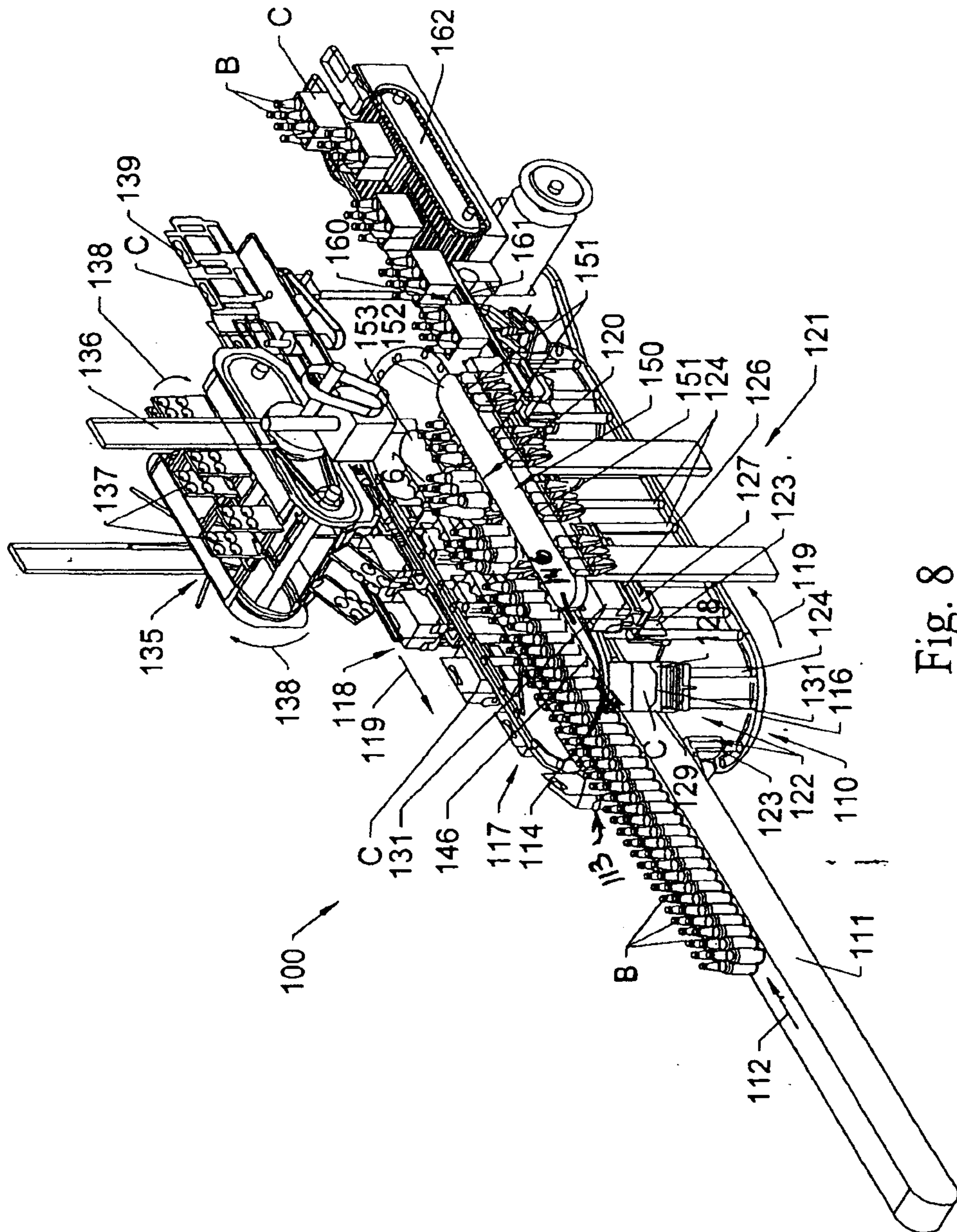

Fig. 8

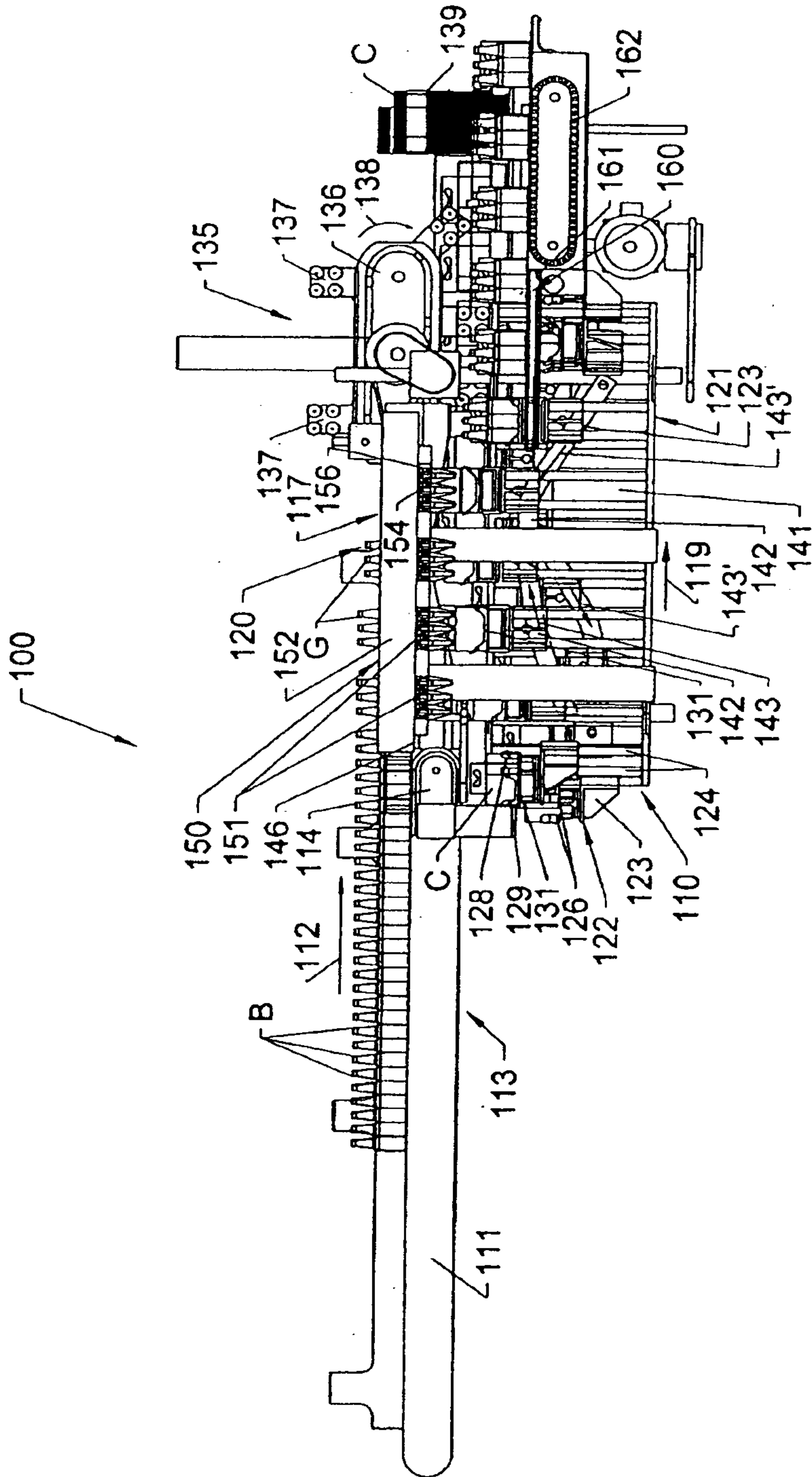

Fig. 9

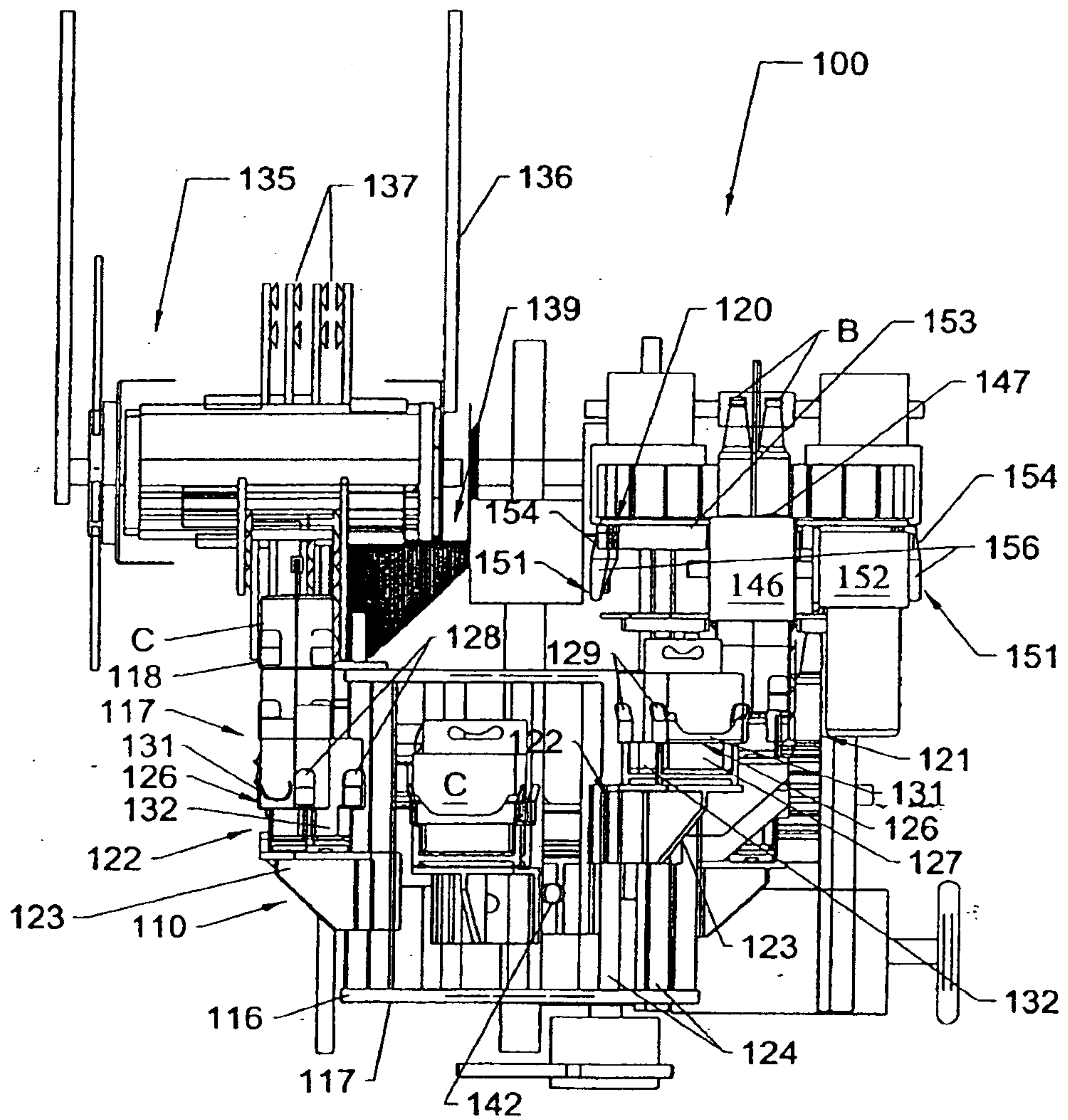

Fig. 10

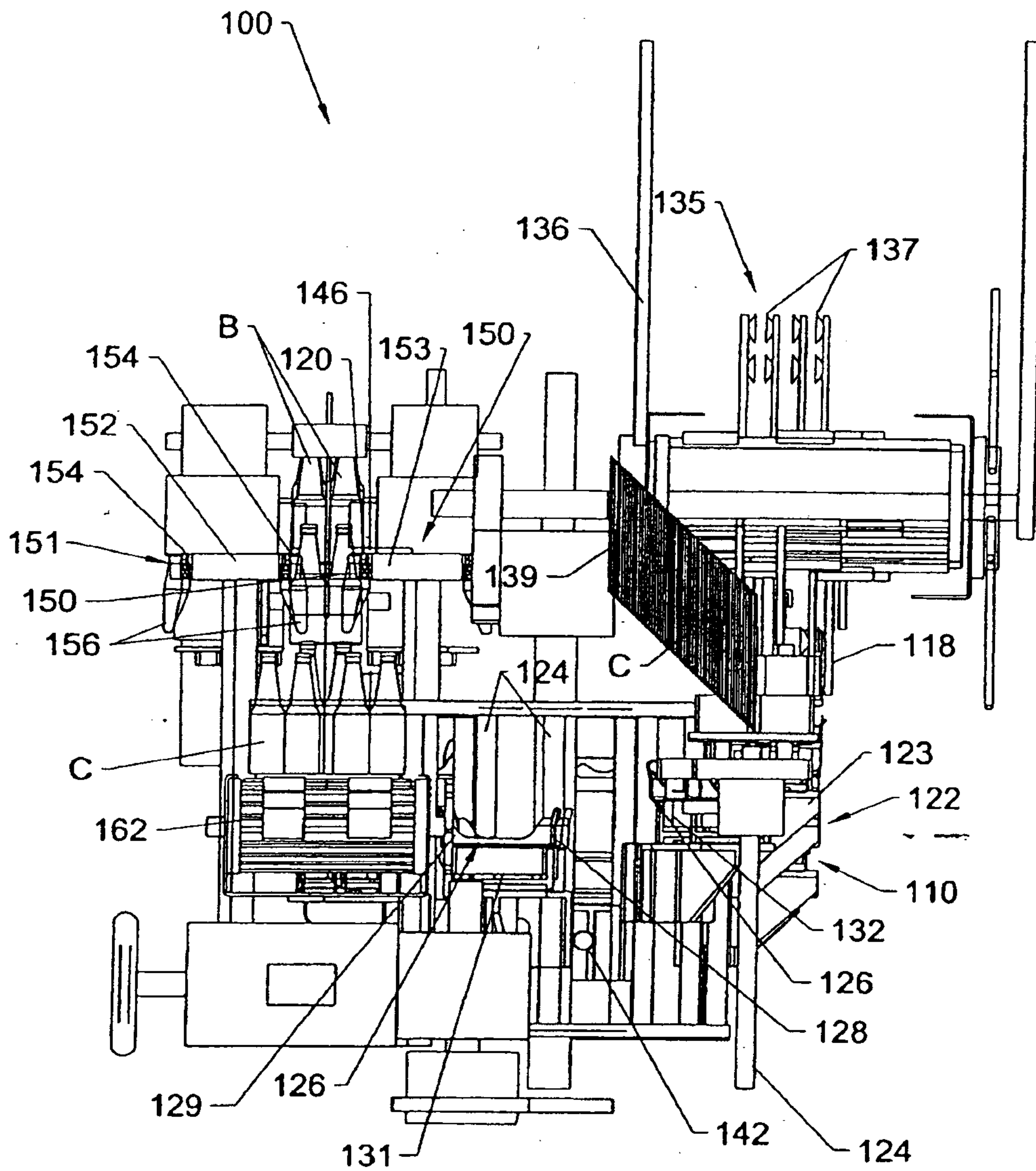

Fig. 11

