

F. VON MARTINI.

Improvement in Breech-Loading Fire-Arms.

No. 132,222.

Patented Oct. 15, 1872.

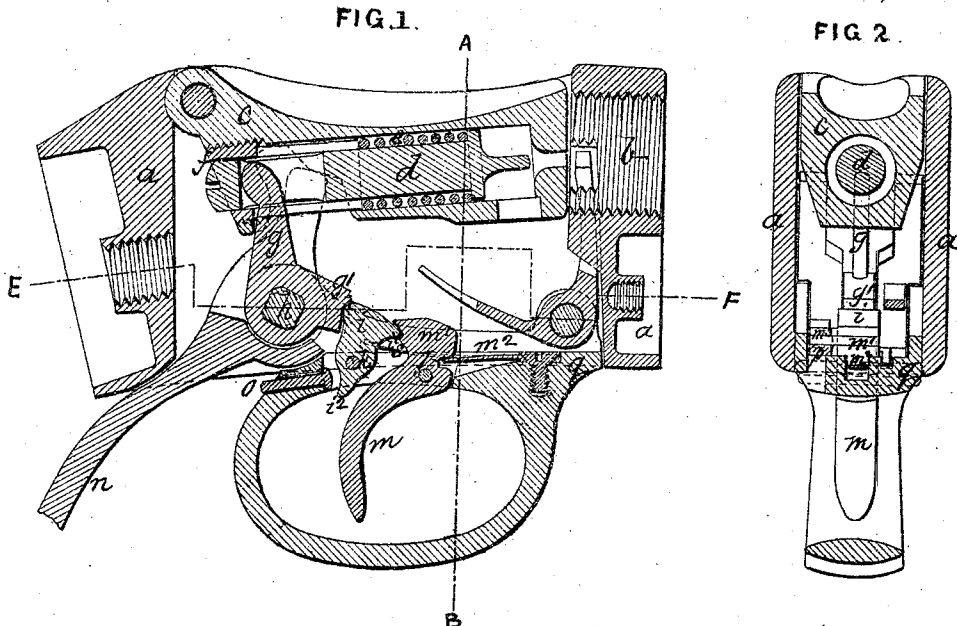

FIG. 4.

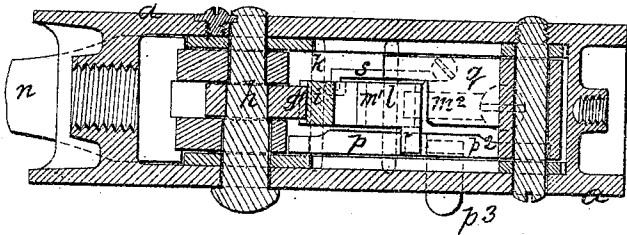

FIG. 3.

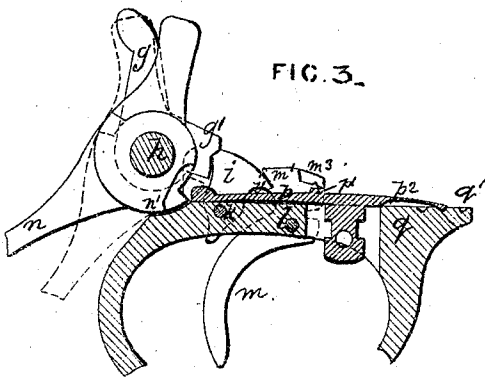
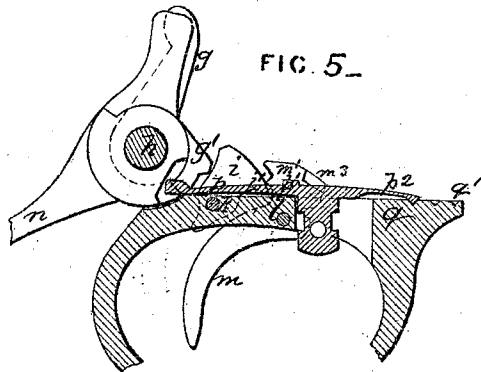

FIG. 5.



Witnesses:

*Wm. H. ...
J. Scher*

F. Martini.

UNITED STATES PATENT OFFICE.

FRIEDRICH VON MARTINI, OF FRAUENFELD, SWITZERLAND.

IMPROVEMENT IN BREECH-LOADING FIRE-ARMS.

Specification forming part of Letters Patent No. 132,222, dated October 15, 1872.

To all whom it may concern:

Be it known that I, FRIEDRICH VON MARTINI, of Frauenfeld, Switzerland, have invented certain Improvements in Breech-Loading Fire-Arms, of which the following is a specification:

The first part of my invention relates to the construction of breech-loading fire-arms with a tumbler-rest working upon a separate axis-pin between the axis-pin of the tumbler-lever and the axis-pin of the trigger, a part of the tumbler-lever resting directly upon the tumbler-rest so as to reduce the pressure on the trigger. The second part of my invention relates to the construction of such arms so as to lock the firing mechanism in the firing position automatically by means of a face on the hand-lever operating upon the locking or safety bolt.

Figure 1 is a central longitudinal vertical section of a breech action embodying my invention, and shows the firing mechanism cocked and locked in the firing position. Fig. 2 is a vertical transverse section, showing those parts of the action which are at the left hand of the line A B drawn across Fig. 1. Fig. 3 is a longitudinal vertical section of the locking-bolt and other parts taken in the line C D of Fig. 4. Fig. 4 is a horizontal section, showing those parts of the action which are below the line E F drawn through Fig. 1. Fig. 5 is a similar view to Fig. 3, but shows the positions of the parts when the trigger has been unlocked and the gun fired.

The action shown is, except as to the tumbler-rest and locking apparatus, constructed on the well-known "Martini" plan, forming the subject of a former patent granted to me, and dated the 25th day of May, 1869, No. 90,614.

a is the lock-frame or body; *b*, the barrel-screw; *c*, the breech-block; *d*, the exploding-pin; *e*, the mainspring; *f*, the tubular screw or stop nut; *g*, the tumbler-lever or tumbler; and *h*, its fulcrum-pin. The short arm *g'* of the tumbler-lever rests directly upon a tumbler-rest, *i*, which works upon a separate axis-pin, *k*, placed between the axis-pin *h* of the tumbler-lever and the axis-pin *l* of the trigger, so that a principal proportion of the pressure communicated from the mainspring *e* to the tumbler-lever *g* is conveyed to and borne by the axis-pin *k*, thus reducing the pressure on

the trigger. The shorter arm *m*¹ of the trigger *m* is formed with a bent, as shown, to receive the nose *i*¹ of the tumbler-rest when the arm is cocked. When the tumbler-rest is released, by pulling the trigger, the pressure of the tumbler-lever *g* against the tumbler-rest *i* causes the latter to turn on its axis until it allows the tumbler-lever to pass, as shown in Fig. 5. During the act of recocking the arm the hand-lever *n* comes in contact with the small sliding pin *o*, thereby pushing the same against the lower arm *i*² of the tumbler-rest, and moving its upper arm back under the short arm *g'* of the tumbler-lever *g*, whereupon the bent in the shorter arm of the trigger is moved by the trigger-spring *m*² into the proper position for receiving the nose *i*¹ of the tumbler-rest, as shown in Fig. 1. The tumbler-rest *i* is recessed to receive the free end of a spring, *s*, which tends to keep the tumbler-rest *i* in the bent formed in the short arm *g'* of the tumbler-lever. In some cases this spring *s* may be made sufficiently powerful to fulfill the office of the sliding pin *o*, which may then be dispensed with. The firing mechanism is locked in the firing position automatically by means of the locking or safety bolt *p*, which is arranged to slide along the trigger-plate *q*, and is actuated by a suitable face, *n'*, on the hand-lever. When the hand-lever *n* is depressed, as shown dotted in Fig. 3, so as to open the breech and cock the piece, it pushes the projecting part *p*¹ of the locking-bolt *p* under the projection or lug *m*³ formed on the trigger *m*, thereby locking the trigger. The bolt *p* is formed with a spring tail-piece, *p*², which catches in indentations formed in the plate *q*, as shown, for retaining the bolt in its respective positions. When the trigger is locked it can only be released by withdrawing the bolt *p* by means of the thumb-piece *p*³, which works in a recess formed in the plate *q*, and is attached to a projecting part of the bolt *p*, as shown. When it is desired to dispense with the automatic locking of the firing mechanism the bolt *p* may be moved forward by means of its thumb-piece until the projection on the under side of the spring tail-piece *p*² takes into the indentation *q'* in the trigger-plate *q*, whereby the bolt will be retained beyond the influence of the hand-lever *n*.

I do not limit the application of my inven-

tion to the precise construction of action shown in the drawing, as the same may be varied without departing from the distinctive character of my invention. I lay no claim to the locking-bolt *p*, except when it is used in combination with a face on the hand-lever, so as to operate automatically; but

What I do claim as my invention is—

1. In breech-loading fire-arms, the combination, with the tumbler-lever and trigger, of a tumbler-rest, working upon a separate axis between the axis-pins of said lever and trigger, said tumbler lever and rest being constructed and arranged to operate in connection with the

trigger, substantially as herein described, so that a part of the tumbler-lever shall rest or press down directly upon the tumbler-rest to reduce the pressure on the trigger, as set forth.

2. In breech-loading fire-arms, the combination, with the firing mechanism and the hand-lever, of a locking or safety bolt, operated by means of a face on said lever to lock said mechanism in the firing position automatically, substantially as shown and set forth.

FR. MARTINI.

Witnesses:

WM. KNOLL,

B. SCHERR.