



(51) International Patent Classification:

B01J 8/02 (2006.01) C07C 29/154 (2006.01)
C07C 29/151 (2006.01) C07C 31/04 (2006.01)

(21) International Application Number:

PCT/EP2019/065133

(22) International Filing Date:

11 June 2019 (11.06.2019)

(25) Filing Language:

English

(26) Publication Language:

English

(30) Priority Data:

PA 2018 00267 12 June 2018 (12.06.2018) DK

(71) Applicant: **HALDOR TOPSØE A/S** [DK/DK]; Haldor
Topsøes Allé 1, 2800 Kgs. Lyngby (DK).

(72) Inventors: **ESKESEN, Søren Grønberg**; Granvej 18A,
3060 Espergerde (DK). **DAHL, Per Juul**; Krumningen 16,
2950 Vedbæk (DK). **TJÄRNEHOV, Emil Andreas**; Skep-
parkroksgatan 1, 216 22 Limhamn (SE). **THORHAUGE,
Max**; Dalbugten 26, 2730 Herlev (DK).

(81) Designated States (unless otherwise indicated, for every

kind of national protection available): AE, AG, AL, AM,
AO, AT, AU, AZ, BA, BB, BG, BH, BN, BR, BW, BY, BZ,
CA, CH, CL, CN, CO, CR, CU, CZ, DE, DJ, DK, DM, DO,
DZ, EC, EE, EG, ES, FI, GB, GD, GE, GH, GM, GT, HN,
HR, HU, ID, IL, IN, IR, IS, JO, JP, KE, KG, KH, KN, KP,
KR, KW, KZ, LA, LC, LK, LR, LS, LU, LY, MA, MD, ME,
MG, MK, MN, MW, MX, MY, MZ, NA, NG, NI, NO, NZ,
OM, PA, PE, PG, PH, PL, PT, QA, RO, RS, RU, RW, SA,
SC, SD, SE, SG, SK, SL, SM, ST, SV, SY, TH, TJ, TM, TN,
TR, TT, TZ, UA, UG, US, UZ, VC, VN, ZA, ZM, ZW.

(84) Designated States (unless otherwise indicated, for every

kind of regional protection available): ARIPO (BW, GH,
GM, KE, LR, LS, MW, MZ, NA, RW, SD, SL, ST, SZ, TZ,
UG, ZM, ZW), Eurasian (AM, AZ, BY, KG, KZ, RU, TJ,
TM), European (AL, AT, BE, BG, CH, CY, CZ, DE, DK,
EE, ES, FI, FR, GB, GR, HR, HU, IE, IS, IT, LT, LU, LV,
MC, MK, MT, NL, NO, PL, PT, RO, RS, SE, SI, SK, SM,
TR), OAPI (BF, BJ, CF, CG, CI, CM, GA, GN, GQ, GW,
KM, ML, MR, NE, SN, TD, TG).

(54) Title: A PROCESS AND A PLANT FOR THE PRODUCTION OF METHANOL

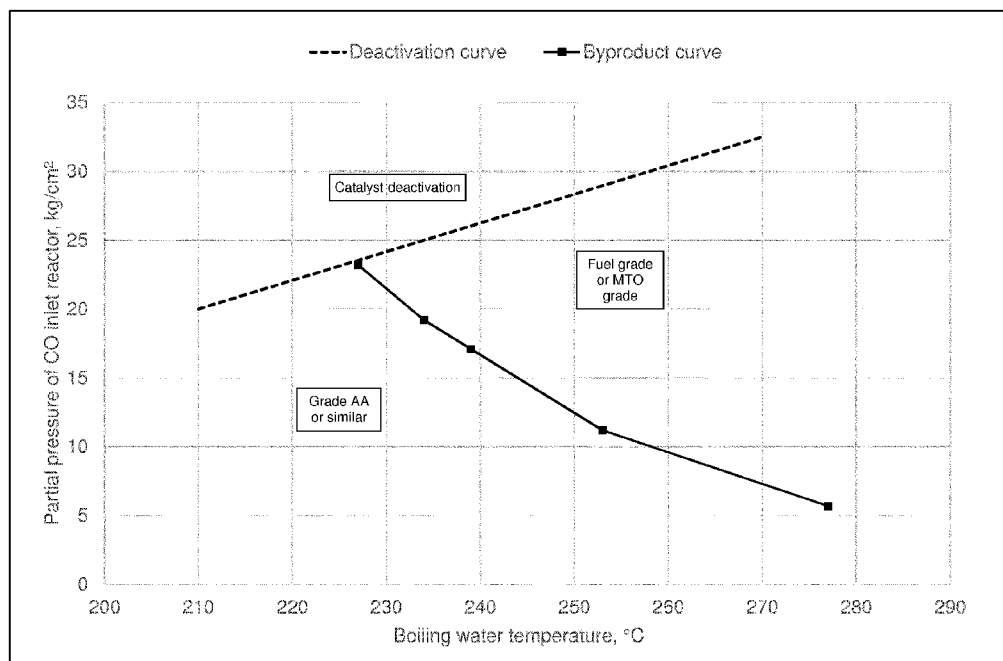

Fig. 1

(57) Abstract: A process for the production of methanol from synthesis gas via an equilibrium reaction is conducted in a methanol preconverter within a certain operational window, said operational window being defined by the area below an approximately linear curve of the partial pressure of carbon monoxide vs. the boiling water temperature for water temperatures between 210 and 270°C. Methanol of different product grades may be obtained by operating in specific areas of the operational window.



Declarations under Rule 4.17:

- *as to the identity of the inventor (Rule 4.17(i))*
- *as to applicant's entitlement to apply for and be granted a patent (Rule 4.17(ii))*
- *as to the applicant's entitlement to claim the priority of the earlier application (Rule 4.17(iii))*
- *of inventorship (Rule 4.17(iv))*

Published:

- *with international search report (Art. 21(3))*

5 **A process and a plant for the production of methanol**

The present invention concerns a process and a plant for the production of methanol. The invention especially has its focus on the operation of methanol reactors. More specifically, the main focus is on the operational window in
10 methanol reactors.

Methods for the production of methanol by catalytic conversion of synthesis gas containing hydrogen and carbon oxides
15 have been known for a long time to persons skilled in the art. Thus, methanol is mainly produced catalytically from a mixture of carbon monoxide, carbon dioxide and hydrogen, i.e. methanol synthesis gas, under high pressure and temperature, most often using a copper-zinc oxide-alumina
20 (Cu/ZnO/Al₂O₃) catalyst.

Methanol is produced from the synthesis gas (syngas) via an equilibrium reaction, which proceeds at elevated temperature under elevated pressure. The synthesis reactions are:

25

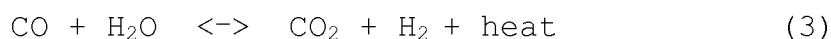
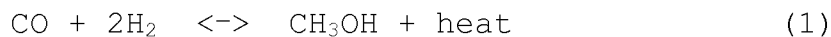

30 Since reactions (1) to (3) are exothermic, the chemical equilibrium constants decrease with increasing temperature. Therefore, low reactor temperatures should improve conver-

sion, provided they are not so low that the specific reaction rates are too small. For a given reactor size and a specific desired conversion, the recycle flow rate increases as reactor temperatures are lowered, which means
5 higher compressor work.

It has turned out that it is advantageous to operate the methanol synthesis reactions in an operational window that is limited by a curve describing the relationship between
10 the partial pressure of CO and the reactor temperature. More specifically, operating within certain combinations of partial CO pressure and temperature will lead to a fast deactivation of the catalyst. This goes for any layout around the methanol reactor, such as the methanol loop with or
15 without pre-converter and irrespective of the layout being a novel design or a revamp.

Depending on the specific combination of the partial pressure of CO and the boiling water temperature, different
20 methanol grades, such as grade AA methanol or fuel grade methanol, can be obtained within the operational window.

A typical methanol plant operated with a natural gas feed is divided into three main sections. In the first part of
25 the plant, natural gas is converted into syngas. The syngas reacts to produce methanol in the second section, and then methanol is purified to the desired purity in the tail-end of the plant. In a standard synthesis loop, a methanol reactor, most often a boiling-water reactor (BWR), is used to
30 convert a mixture of synthesis gas from a reformer/gasifier unit and recycle gas, i.e. unconverted synthesis gas, into methanol.

It has been found that a region of specific combinations of the partial CO pressure and the reactor temperature (in practice the boiling water temperature) can be established, within which it is considered "safe" to operate in the sense that advantageous results are obtained. More specifically, an approximately linear curve can be drawn for boiling water temperatures between 210°C and 270°C. In this specific temperature range, the partial CO pressure corresponding to a given temperature displays an approximately linear increase from 20 kg/cm² at 210°C to 32.5 kg/cm² at 270°C. The area below this curve defines the "safe" region of operation.

So the present invention concerns a process for the production of methanol from synthesis gas via an equilibrium reaction proceeding at elevated temperatures under elevated pressure according to the above synthesis reactions (1) to (3), said process being conducted in a methanol pre-converter within an operational window, said operational window being

- defined by the area below an approximately linear curve of the partial pressure of carbon monoxide vs. the boiling water temperature for water temperatures from 210 to 270°C, where the partial pressure of carbon monoxide increases from 20 kg/cm² at 210°C to 32.5 kg/cm² at 270°C, and

- divided into two areas by an estimated bi-product curve of the partial pressure of carbon monoxide vs. the boiling water temperature, said areas leading to the production of methanol of different product qualities.

The process preferably is conducted in an area within the operational window to the left of and below the estimated by-product curve, which indicates the upper limit for obtaining grade AA methanol or methanol of similar quality. The estimated by-product curve is shown in Fig. 1 which identifies the operational window to be used in the process according to the invention.

It is well known in the art that a synthesis gas derived from natural gas or heavier hydrocarbons and coal is highly reactive for direct methanol synthesis and harmful for the catalyst. Moreover, use of such highly reactive synthesis gas results in formation of large amounts of by-products.

The reaction of carbon oxides and hydrogen to methanol is equilibrium-limited, and the conversion of the synthesis gas to methanol per pass through the methanol catalyst is relatively low, even when using a highly reactive synthesis gas.

Because of the low methanol production yield in a once-through conversion process, the general practice in the art is to recycle unconverted synthesis gas separated from the reaction effluent and dilute the fresh synthesis gas with the recycle gas.

This typically results in the so-called methanol synthesis loop with one or more reactors connected in series being operated on fresh synthesis gas diluted with recycled unconverted gas separated from the reactor effluents or on the reactor effluent containing methanol and unconverted

synthesis gas. The recycle ratio (recycle gas to fresh synthesis feed gas) is from 2:1 up to 7:1 in normal practice.

5 When the methanol reactor in an existing methanol plant becomes the bottleneck in connection with capacity revamp projects, the standard solution is to install an extra reactor in series or in parallel or to modify the existing reactor. This is typically all done inside the loop. It has, however, turned out to be an advantage to install a
10 once-through pre-converter between the make-up gas compressor and the methanol loop. This concept maintains the existing loop unchanged.

15 So, according to a preferred embodiment of the present invention, a once-through pre-converter is installed between the make-up gas compressor and the methanol loop, said pre-converter operating within the inventive operational window limited by a curve describing the relationship between the partial pressure of CO and the reactor temperature.

20

As regards prior art, Applicant's WO 2015/193440 A1 describes a process for producing methanol in reactors connected in series, where one of the aspects is to apply the process as part of a revamp, thereby providing a way to
25 increase the production capacity of an existing methanol plant.

In Applicant's WO 2014/012601 A1, a reaction system for the preparation of methanol is described, which comprises two
30 reaction units, of which the first unit is operated on a mixture of fresh synthesis gas and unconverted synthesis

gas while the second unit is operated solely on unconverted synthesis gas.

5 US 5.631.302 A describes production of methanol on copper-containing catalysts from a synthesis gas under a pressure from 20 to 120 bar at a temperature of 200-350°C. The synthesis gas is passed adiabatically through a first synthesis reactor containing a fixed bed of a copper-containing catalyst without any synthesis gas recycle. Together with
10 recycle gas, the gas mixture which has not been reacted in the first synthesis reactor is passed through a second synthesis reactor, which contains a copper-containing catalyst disposed in tubes and indirectly cooled by boiling water.

15 In WO 2014/095978 A2, also belonging to the Applicant, a process for the production of higher (C₄₊) alcohols is described, in which the alcohol synthesis gas is optionally first reacted in a heterogeneous alcohol pre-converter, whereby methanol is produced, and then the effluent from
20 the pre-converter - or the synthesis gas in the absence of the pre-converting step - is reacted in a reactor for synthesis of higher alcohols.

25 In WO 2017/121981 A1, a methanol synthesis process is described, which comprises the steps of (i) passing a first synthesis gas mixture comprising a make-up gas through a first synthesis reactor to form a first product gas stream, (ii) recovering methanol from the first product gas stream, thereby forming a first methanol-depleted gas mixture,
30 (iii) combining the first methanol-depleted gas mixture with a loop recycle stream to form a second synthesis gas mixture, (iv) passing the second synthesis gas mixture

through a second synthesis reactor to form a second product gas stream, (v) recovering methanol from the second product gas stream, thereby forming a second methanol-depleted gas mixture, and (vi) using at least part of the second methanol-depleted gas mixture as the loop recycle gas stream. In this process, the first synthesis reactor has a higher heat transfer per m³ of catalyst than the second synthesis reactor, and none of the loop recycle gas stream is fed to the first synthesis gas mixture, and the recycle ratio of the loop recycle gas stream to form the second synthesis gas mixture is in the range from 1.1:1 to 6:1. It is stated that the efficiency of multiple-stage methanol synthesis may be improved by using different recycle ratios for different types of reactor.

15

The best choice for the pre-converter to be used according to the invention is a boiling water reactor because of the very reactive synthesis gas. In order to limit the formation of by-products, a lower boiling water temperature in the pre-converter than in the existing reactor typically will be required, which in turn requires a separate steam drum.

20

The pre-converter concept according to the invention supplies the extra catalyst needed to process the extra make-up gas originating from upstream units. The pre-converter itself operates on fresh make-up gas. It is preferably of the boiling water reactor (BWR) type and will require an additional cooling system and possibly also individual cooling and separation of the condensed methanol from the pre-converter. The fresh make-up gas is very reactive towards by-product formation. A lower catalyst temperature

25
30

therefore is foreseen compared to the existing reactor,
hence the additional cooling system.

The invention is described in more detail with reference to
5 the figures, where

Fig. 1 shows the operational window to be used in the pro-
cess according to the invention,

10 Fig. 2 shows an embodiment of the pre-converter concept ac-
cording to the invention, and

Fig. 3 shows an alternative embodiment of the pre-converter
concept according to the invention.

15

In Fig. 1, the operational window to be used in the process
according to the invention is defined by the area below the
approximately linear, dashed curve (the deactivation curve)
of the partial pressure of carbon monoxide vs. the boiling
20 water temperature for water temperatures from 210 to 270°C,
where the partial pressure of carbon monoxide increases
from 20 kg/cm² at 210°C to 32.5 kg/cm² at 270°C.

As already mentioned, it is possible to obtain different
25 methanol grades within the operational window depending on
the combination of partial pressure of CO and boiling water
temperature. In Fig. 1, the solid curve (the byproduct
curve) indicates the upper limit for obtaining grade AA
methanol or methanol of similar high quality. Operating
30 above the curve will move the methanol product into a more
byproduct-containing methanol product which is, however,

pure enough to be counted as fuel grade or methanol-to-olefins (MTO) grade methanol.

Furthermore, the dashed deactivation curve depicts the limit for catalyst deactivation. Operating above the curve will lead to a fast deactivation of the catalyst.

5 In Fig. 2, compressed make-up synthesis gas 1 (compressor not shown) is heated in the feed/effluent heat exchanger (hex1) before it enters the pre-converter (A). After being
10 passed through the pre-converter, the gas 2 is cooled in the feed/effluent heat exchanger (hex1) and sent to a condenser c1, optionally sent to another condenser c2 as stream 9. As much as possible of the methanol is condensed in condenser c1 before the two-phase flow is separated in a
15 first separator (s1). The gas 3 from the separator (s1) is then mixed with the gas 4 from a second separator (s2) or optionally sent directly downstream the recirculator (R) as stream 5.

20 After mixing, the gas is compressed in said recirculator (R). The resulting feed gas 6 to the reactor (B) is pre-heated in the feed/effluent heat exchanger (hex2) before it enters the reactor (B).

25 The outgoing gas 7 is cooled in the feed/effluent heat exchanger (hex2) prior to being cooled as much as possible in condenser c2 in order to condense as much methanol as possible. Then the two-phase flow is separated in the second separator (s2).

30

A small amount 8 of the gas from the separator (s2) is sent to purge to avoid build-up of inert constituents. The rest

of the gas flow from the separator (s2) is mixed with the gas from the separator (s1). Finally, the liquids from the two separators (s1) and (s2) are mixed, and the mixture is sent to a low pressure separator before being sent out of the methanol section.

Fig. 3 shows another embodiment, different from the one shown in Fig. 2. Here, the make-up synthesis gas (1') is compressed (compressor not shown), and the compressed gas is mixed with part of the recycled gas from the recirculator R' and heated in the feed/effluent heat exchanger (hex1') before it enters the pre-converter (A'). After passing through the pre-converter, the gas 2' is cooled in the feed/effluent heat exchanger (hex1'). Then the cooled gas from the pre-converter (A') is mixed with cooled gas from the reactor (B'). After the mixing, the two-phase flow is cooled further in condenser c1' to condense as much methanol as possible.

When the gas has cooled as much as possible, the two-phase flow is separated in a separator (s1'). Some of the outgoing gas from the separator is sent to purge to avoid build-up of inert constituents. The rest of the gas is sent to the recirculator R' and used as feed gas to the reactor (B'). The feed gas to reactor (B') is heated in the feed/effluent heat exchanger (hex2') before it enters the reactor. After reactor (B'), the gas is cooled in the feed/effluent heat exchanger (hex2') and mixed with cooled gas from the pre-converter (A').

30

Optionally, the cooled gas from the pre-converter (A') is fed to another condenser c2' to condense as much methanol

as possible. After the gas has cooled, the two-phase flow is separated in another separator (s2'), from where the gas phase is sent to the inlet of the recirculator R', while the liquid phase is mixed with the liquid phase from separator s1'.

The fresh make-up gas is very reactive towards formation of by-products. A lower catalyst temperature compared to the existing reactor can therefore be foreseen; hence the additional cooling system.

Claims:

1. A process for the production of methanol from synthesis gas via an equilibrium reaction proceeding at elevated temperatures under elevated pressure according to the synthesis reactions

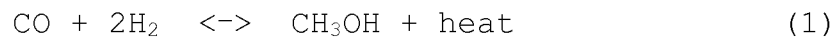

in the presence of a catalyst, said process being conducted in a methanol pre-converter within an operational window, said operational window being

15

- defined by the area below an approximately linear curve of the partial pressure of carbon monoxide vs. the boiling water temperature for water temperatures from 210 to 270°C, where the partial pressure of carbon monoxide increases from 20 kg/cm² at 210°C to 32.5 kg/cm² at 270°C, and

20

- divided into two areas by an estimated by-product curve of the partial pressure of carbon monoxide vs. the boiling water temperature, said areas leading to the production of methanol of different product qualities.

25

2. Process according to claim 1, which is conducted in an area within the operational window to the left of and below the by-product curve, which indicates the upper limit for obtaining grade AA methanol or methanol of similar quality.

30

3. Process according to claim 1, which is conducted in an area within the operational window to the right of and above the by-product curve, where the methanol product is a more byproduct-containing methanol product which is still
5 pure enough to be a fuel grade or methanol-to-olefins (MTO) grade methanol.

4. Process according to claim 1, wherein the catalyst is
10 a Cu/ZnO-based catalyst.

5. A plant for the production of methanol by the process according to claim 1 or 2, said plant comprising a make-up
15 gas compressor and a synthesis reactor in a methanol loop, wherein a once-through pre-converter is installed between the make-up gas compressor and the methanol loop, said pre-converter operating within the operational window defined
20 by the area below the approximately linear, dashed curve of the partial pressure of carbon monoxide vs. the boiling water temperature for water temperatures from 210 to 270°C, where the partial pressure of carbon monoxide increases from 20 kg/cm² at 210°C to 32.5 kg/cm² at 270°C.

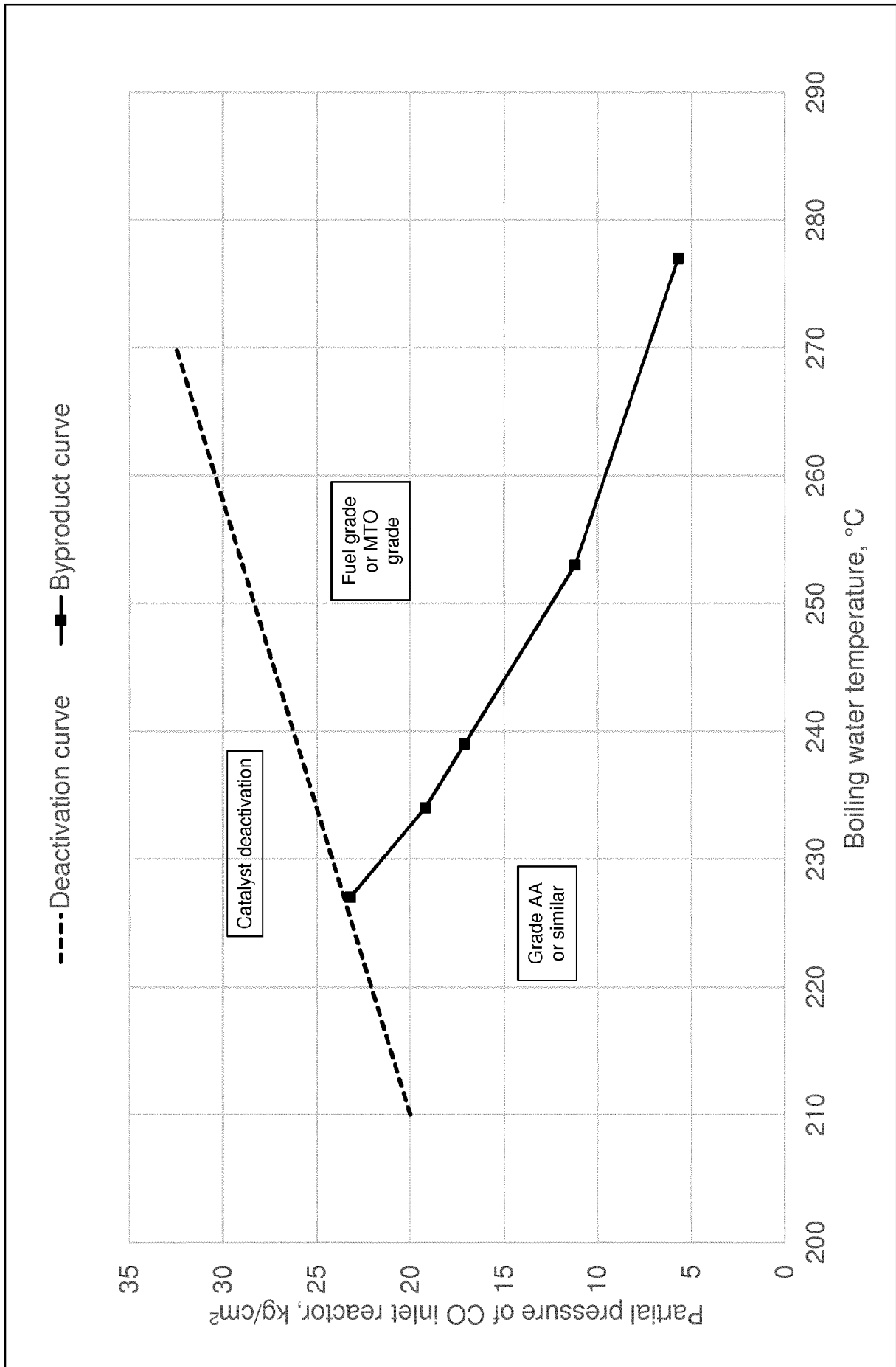

Fig. 1

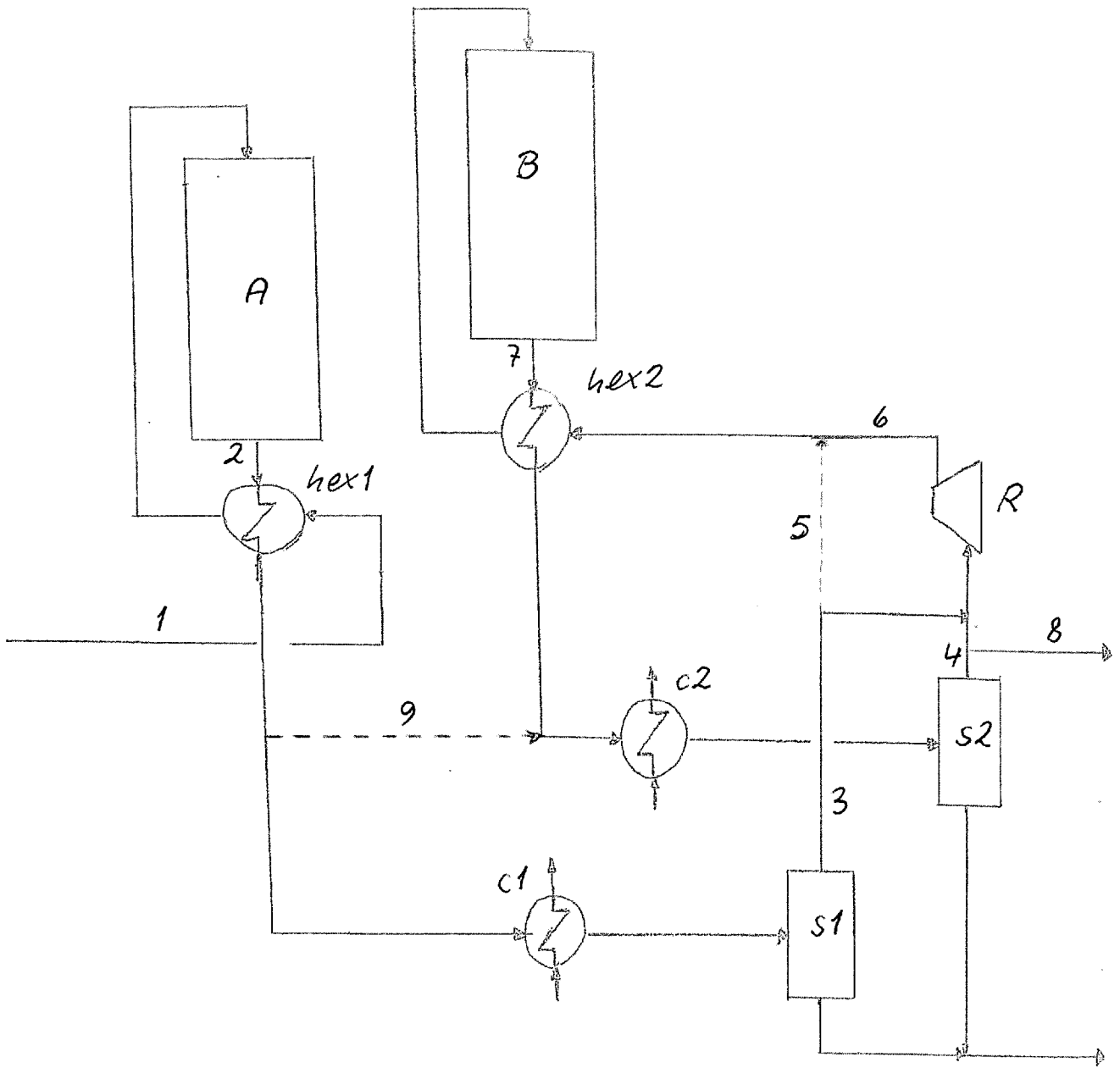

Fig. 2

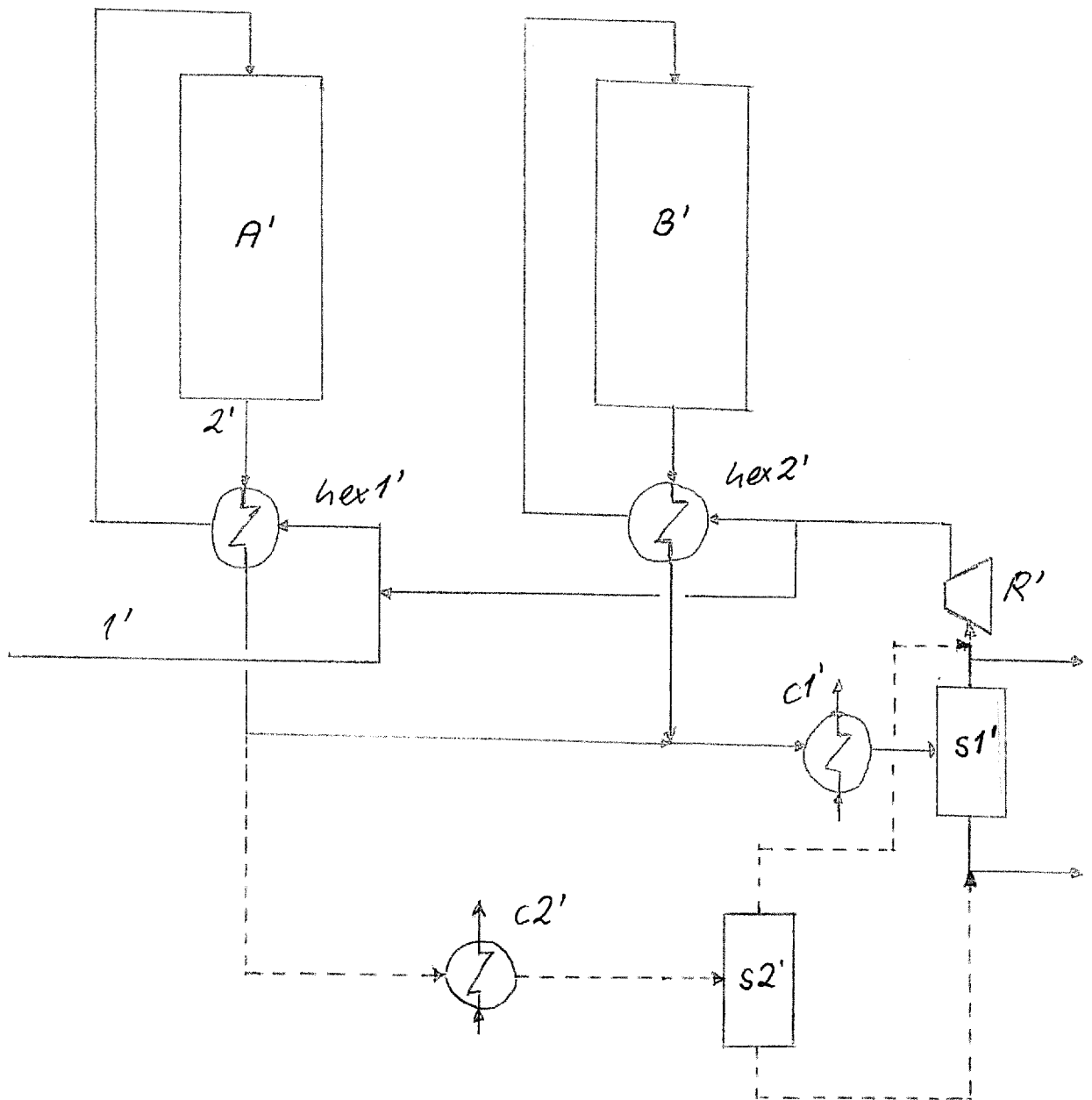

Fig. 3

INTERNATIONAL SEARCH REPORT

International application No
PCT/EP2019/065133

A. CLASSIFICATION OF SUBJECT MATTER
INV. B01J8/02 C07C29/151 C07C29/154 C07C31/04
ADD.
According to International Patent Classification (IPC) or to both national classification and IPC

B. FIELDS SEARCHED
Minimum documentation searched (classification system followed by classification symbols)
B01J C07C
Documentation searched other than minimum documentation to the extent that such documents are included in the fields searched

Electronic data base consulted during the international search (name of data base and, where practicable, search terms used)
EPO-Internal, CHEM ABS Data

C. DOCUMENTS CONSIDERED TO BE RELEVANT

Category*	Citation of document, with indication, where appropriate, of the relevant passages	Relevant to claim No.
X	WO 2017/025272 A1 (HALDOR TOPSØE AS [DK]) 16 February 2017 (2017-02-16)	5
A	claims 1-9 figure 1	1-4
A	----- WO 2017/167642 A1 (HALDOR TOPSØE AS [DK]) 5 October 2017 (2017-10-05) abstract claims 1-6 page 11, line 4 - line 7 -----	1-5

Further documents are listed in the continuation of Box C.

See patent family annex.

* Special categories of cited documents :

- "A" document defining the general state of the art which is not considered to be of particular relevance
- "E" earlier application or patent but published on or after the international filing date
- "L" document which may throw doubts on priority claim(s) or which is cited to establish the publication date of another citation or other special reason (as specified)
- "O" document referring to an oral disclosure, use, exhibition or other means
- "P" document published prior to the international filing date but later than the priority date claimed

- "T" later document published after the international filing date or priority date and not in conflict with the application but cited to understand the principle or theory underlying the invention
- "X" document of particular relevance; the claimed invention cannot be considered novel or cannot be considered to involve an inventive step when the document is taken alone
- "Y" document of particular relevance; the claimed invention cannot be considered to involve an inventive step when the document is combined with one or more other such documents, such combination being obvious to a person skilled in the art
- "&" document member of the same patent family

Date of the actual completion of the international search

6 September 2019

Date of mailing of the international search report

19/09/2019

Name and mailing address of the ISA/
European Patent Office, P.B. 5818 Patentlaan 2
NL - 2280 HV Rijswijk
Tel. (+31-70) 340-2040,
Fax: (+31-70) 340-3016

Authorized officer

Delanghe, Patrick

INTERNATIONAL SEARCH REPORT

Information on patent family members

International application No PCT/EP2019/065133

Patent document cited in search report	Publication date	Patent family member(s)	Publication date
WO 2017025272 A1	16-02-2017	CN 107922297 A	17-04-2018
		EP 3334704 A1	20-06-2018
		US 2018237366 A1	23-08-2018
		WO 2017025272 A1	16-02-2017

WO 2017167642 A1	05-10-2017	AU 2017242105 A1	04-10-2018
		BR 112018069902 A2	05-02-2019
		CA 3019431 A1	05-10-2017
		CN 108884008 A	23-11-2018
		EA 201892103 A1	30-04-2019
		EP 3436421 A1	06-02-2019
		KR 20180128448 A	03-12-2018
		US 2019126231 A1	02-05-2019
		WO 2017167642 A1	05-10-2017
