

(19) World Intellectual Property Organization
International Bureau



(43) International Publication Date
3 May 2001 (03.05.2001)

PCT

(10) International Publication Number
WO 01/31802 A1

- (51) International Patent Classification⁷: H04B 1/40 462-130 (KR). LEE, Jae-Min; Jangmimaetul Hyundae Apt. #828, Yatap-dong -, Puntang-gu, Songnam-shi, Kyonggi-do 463-070 (KR). LEE, Woo-Yong; 96 Sohyon-dong, Puntang-gu, Songnam-shi, Seoul 463-050 (KR).
- (21) International Application Number: PCT/KR00/01212
- (22) International Filing Date: 26 October 2000 (26.10.2000)
- (25) Filing Language: English (74) Agent: LEE, Keon-Joo; Mihwa Building, 110-2, Myongryun-dong 4-ga, Chongro-gu, Seoul 110-524 (KR).
- (26) Publication Language: English (81) Designated States (national): AU, CN, JP.
- (30) Priority Data: (84) Designated States (regional): European patent (AT, BE, CH, CY, DE, DK, ES, FI, FR, GB, GR, IE, IT, LU, MC, NL, PT, SE).
1999/46584 26 October 1999 (26.10.1999) KR
2000/33260 16 June 2000 (16.06.2000) KR
- (71) Applicant: SAMSUNG ELECTRONICS CO., LTD. [KR/KR]; 416, Maetan-dong, Paldal-gu, Suwon-shi, Kyungki-do 442-370 (KR). Published:
— With international search report.

(72) Inventors: PARK, Seong-Kil; 77-14, #101, Songnam-dong, Chungwon-gu, Songnam-shi, Kyonggi-do
For two-letter codes and other abbreviations, refer to the "Guidance Notes on Codes and Abbreviations" appearing at the beginning of each regular issue of the PCT Gazette.

(54) Title: APPARATUS AND METHOD FOR CONTROLLING TRANSMISSION POWER OF MOBILE STATION

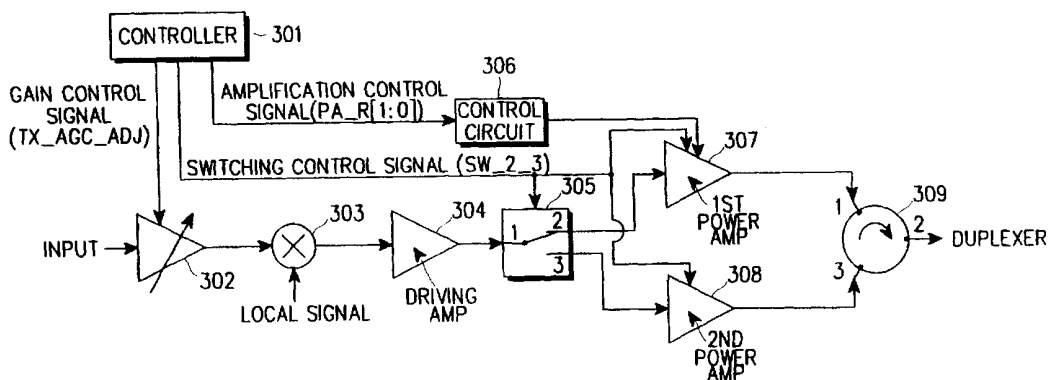

(57) Abstract: There is provided an apparatus and method for controlling the output power of mobile station. The output power controlling apparatus has a first power amplifier having high efficiency when the output power of the mobile station is high, a second power amplifier having high efficiency when the output power is low, a switch for switching an RF signal to one of the two power amplifiers, and a circulator for connecting the outputs of the two power amplifiers to a duplexer. To control the output power of the mobile station, the strength of a signal received from a base station is measured. The output power level of the mobile station is determined based on the signal strength measurement. One of the two power amplifiers is activated according to the determined output level. The switch is controlled to switch the RF signal to the activated power amplifier.



WO 01/31802 A1

**APPARATUS AND METHOD FOR CONTROLLING TRANSMISSION POWER
OF MOBILE STATION**

5

BACKGROUND OF THE INVENTION

1. Field of the Invention

10 The present invention relates generally to an apparatus and method for controlling a power amplifier in a mobile station, and in particular, to a transmitting apparatus and method for a mobile station, where at least two power amplifiers are connected in parallel.

2. Description of the Related Art

15 Most of the power consumption of a mobile station during a call generally occurs in a power amplifier. Therefore, research has been carried out on optimum power dissipation of the power amplifier in order to maximize a call time for the mobile station. For this purpose, current power amplifiers are provided with power control ports. However, optimum power control of power amplifiers varies with the types of the power amplifiers, and the power amplifiers show non-linear characteristics depending on output levels. Power control has conventionally been implemented on a power amplifier by either increasing the efficiency of the power amplifier through application of four discontinuous control voltages to the control port of the power amplifier according to the output level of a transmitting device in the mobile station (see FIG. 1), or simultaneously controlling an automatic gain control (AGC) amplifier and the power amplifier by means of a gain control signal TX_AGC_ADJ being a PDM (Pulse Density Modulation) signal used for the AGC power amplifier in the transmitting device (see FIG. 2).

25 FIG. 1 illustrates a power amplifier with a bias current fixed according to a highest transmission power level in a conventional mobile station. Referring to FIG. 1, a controller 101 provides overall control to the mobile station. In particular, the controller 101 applies the gain control signal TX_AGC_ADJ being a PDM signal to an AGC amplifier 102 and an amplification control signal to a control circuit 106, respectively. The AGC amplifier 102 controls the gain of an input signal in response to the gain control signal received from the controller 101. A mixer 103 mixes the output of the AGC

30

35

- 2 -

amplifier 102 with a local signal generated from a local oscillator (not shown), for frequency conversion which increases the frequency of the output of the AGC amplifier 102. A driving amplifier 104 amplifies the output of the mixer 103. The control circuit 106 applies a control voltage to a power amplifier 105 to control the power amplifier 105 in response to the amplification control signal received from the controller 101. Here, the control circuit 106 feeds four kinds of control voltages to the power amplifier 105. The power amplifier 105 amplifies a signal received from the driving amplifier 104 according to the transmission power of the mobile station in response to the received control voltage.

FIG. 2 illustrates a method of controlling a power amplifier using a gain control signal for an AGC amplifier in another conventional mobile station. Referring to FIG. 2, a controller 201 provides overall control to the mobile station. In particular, the controller 201 applies the gain control signal TX_AGC_ADJ to both an AGC amplifier 202 and a control circuit 206. The AGC amplifier 202 controls the gain of an input signal in response to the gain control signal. A mixer 203 mixes the output of the AGC amplifier 202 with a local signal generated from a local oscillator (not shown), for frequency conversion which increases the frequency of the output of the AGC amplifier 202. A driving amplifier 204 amplifies the output of the mixer 203. The control circuit 206 outputs a control voltage to a power amplifier 205 to control the power amplifier 205 in response to the gain control signal. The power amplifier 205 amplifies a signal received from the driving amplifier 204 in response to the transmission power of the mobile station. A digital modem may be used as the controllers 101 and 201 as described above.

According to the method depicted in FIG. 1, four control voltages are generated using binary signals PA_R0 and PA_R1 generated from a digital modem chip. An approximate 70 to 80dB transmission power range of the mobile station from -50dBm to 24 or 30dBm is divided into four sections and one control voltage is applied in each section. This conventional control method has limitations in providing a non-linear continuous optimum power voltage. As a result, it is impossible to maximize power use efficiency.

The above two methods commonly intend to achieve maximum efficiency by controlling a bias current to be applied to a power amplifier. However, these methods cannot achieve efficiency above a specific level because the power amplifiers used basically have high efficiency at a maximal power level.

- 3 -

Maximum efficiency cannot be obtained by discontinuously controlling a power amplifier by the use of a few control voltages because an optimal control voltage for the power amplifier is non-linear and shows continuous variation according to output levels. Furthermore, it is difficult to implement hardware that outputs the optimal control voltage by means of the gain control signal TX_AGC_ADJ used to control the AGC amplifier 202 as shown in FIG. 2.

It is known from much test data that the transmission power of a mobile station is mostly 0dBm or below. However, a conventional power amplifier exhibits very low efficiency, say, 5% or below at or below 0dBm since the efficiency of the power amplifier is set according to maximal transmission power. Consequently, a conventional mobile station with a power amplifier showing high efficiency at a maximal power level operates with very low energy efficiency for most of the time.

15

SUMMARY OF THE INVENTION

It is, therefore, an object of the present invention to provide an apparatus and method for achieving high energy efficiency even in a low power state by using a power amplifier that has high efficiency above 20% with low power in the low power state and a power amplifier that has high efficiency with maximal power in a high power state, like a conventional power amplifier, according to output power levels of a mobile station.

It is another object of the present invention to provide an apparatus and method for minimizing the influence of the output impedance of each of the power amplifiers with different characteristics on a matching circuit at the output side of the other power amplifier by connecting a circulator to the output ports of the power amplifiers in a mobile station.

The above objects can be achieved by providing an apparatus and method for controlling the output power of a mobile station. The output power controlling apparatus has a first power amplifier having high efficiency when the output power of the mobile station is high, a second power amplifier having high efficiency when the output power is low, a switch for switching an RF signal to one of the two power amplifiers, and a circulator for connecting the outputs of the two power amplifiers to a duplexer. To control

35

- 4 -

the output power of the mobile station, the strength of a signal received from a base station is measured. The output power level of the mobile station is determined based on the signal strength measurement. One of the two power amplifiers is activated according to the determined output level. The switch is controlled to switch the RF signal to the activated power amplifier.

BRIEF DESCRIPTION OF THE DRAWINGS

The above and other objects, features and advantages of the present invention will become more apparent from the following detailed description when taken in conjunction with the accompanying drawings in which:

FIG. 1 illustrates a power amplifier with a bias current fixed according to maximal transmission power in a conventional mobile station;

FIG. 2 illustrates a method of controlling a power amplifier by means of a gain control signal used for an AGC amplifier in another conventional mobile station;

FIG. 3 is a block diagram of a transmitting device in a mobile station according to a preferred embodiment of the present invention;

FIG. 4 is a block diagram of a transmitting device in a mobile station according to another preferred embodiment of the present invention;

FIG. 5 is a block diagram of a transmitting device in a mobile station according to a third preferred embodiment of the present invention;

FIG. 6 is a block diagram of a transmitting device in a mobile station according to a fourth preferred embodiment of the present invention;

FIG. 7 is a block diagram of a control signal generating unit to control the transmitting device shown in FIG. 3;

FIG. 8 is a block diagram of a control signal generating unit to control the transmitting device shown in FIG. 6; and

FIG. 9 is a hysteresis curve of a switching control signal according to the present invention.

DETAILED DESCRIPTION OF THE PREFERRED EMBODIMENTS

Preferred embodiments of the present invention will be described herein below with reference to the accompanying drawings. In the following description, well-known functions or constructions are not described in detail since they would obscure the

invention in unnecessary detail.

5 A mobile station according to the present invention includes an AGC amplifier, a mixer, a driving amplifier, and a controller for controlling those components, like a conventional mobile station. The mobile station further has two power amplifiers with different operating characteristics connected in parallel, a power switch for switching the output of the driving amplifier to the power amplifiers, and a circulator for connecting the outputs of the power amplifiers to a duplexer.

10 Hereinafter, a power amplifier having high efficiency at a high output level of the mobile station is referred to as a first power amplifier, and a power amplifier having high efficiency at a low output level of the mobile station is referred to as a second power amplifier. The output of the driving amplifier is called a radio frequency (RF) signal.

15 FIG. 3 is a block diagram of a transmitting device in a mobile station according to an embodiment of the present invention.

Referring to FIG. 3, a controller 301 provides overall control to the mobile station. In particular, the controller 301 feeds a gain control signal TX_AGC_ADJ to an AGC
20 amplifier 302, an amplification control signal PA_R [1:0] to a control circuit 306, and a switching control signal SW_2_3 to a switch 305, a first power amplifier 307, and a second power amplifier 308.

25 The AGC amplifier 302 controls the gain of an input signal to a corresponding level in response to the gain control signal. A mixer 303 mixes the output of the AGC amplifier 302 with a local signal generated from a local oscillator (not shown), for frequency conversion which increases the frequency of the output of the AGC amplifier 302. A driving amplifier 304 amplifies the output of the mixer 303. The control circuit 306
30 outputs a control voltage to the first power amplifier 307 to control the first power amplifier 307 in response to the amplification control signal.

35 The switch 305 has a common port 1 connected to the output port of the driving amplifier 304, a first output port 2 connected to the input port of the first power amplifier 307, and a second output port 3 connected to the input port of the second power amplifier 308. The switch 305 switches the RF signal received from the driving amplifier 304 to the

- 6 -

first or second power amplifier 307 or 308 according to the switching control signal received from the controller 301. The first and second power amplifiers 307 and 308 amplify the power of the RF signal received from the switch 305.

5 A circulator 309 has a first port 1 connected to the first power amplifier 307, a third port 3 connected to the second power amplifier 308, and a second port 2 connected to a duplexer (not shown). The circulator 309 connects the outputs of the first and second power amplifiers 307 and 308 to the duplexer.

10 As to the output power of the mobile station in time during a call, the mobile station uses power between -10 and 0 dBm most frequently. Output power at or above 0 dBm occupies only 10% of a total call time. Consequently, the invention uses an additional second power amplifier having high efficiency at a low power level of 0 dBm or below at which the mobile station operates for most call time.

15 At or below a threshold (e.g., 0 dBm), that is, when the mobile station is placed in a low power state, the output of the driving amplifier 304 is connected to the input of the second power amplifier 308 and the first power amplifier 307 is deactivated, to thereby increase system energy efficiency. Since the circulator 309 routes a signal in the direction
20 of 1-2-3-1, the output of the second power amplifier 308 is connected to the first port of the circulator 309 instead of the third port. However, the deactivation of the first power amplifier 307 brings about reflection of the most power and consequently connects the output of the second power amplifier 308 to the duplexer.

25 On the other hand, in a high power state, the switch 305 switches the RF signal of the driving amplifier 304 to the first power amplifier 307 and the second power amplifier 308 is deactivated. The circulator 309 connects the output of the first power amplifier 307 received through the first port 1 to the duplexer through the second port 2. Since the
30 second power amplifier 308 is deactivated in the high power state, the output impedance of the second power amplifier 308 has little influence on a matching circuit at the output side of the first power amplifier 307.

35 Here, the switch 305 can be switched directly to the circulator 309 without interposition of the second power amplifier 308. This implies that the mobile station transmits data in the low power state without power amplification

- 7 -

FIG. 7 is a block diagram of a control signal generating unit for generating the amplification control signal PA_R, the gain control signal TX_AGC_ADJ, and the switching control signal SW_2_3. The control signal generating unit is provided in the controller of the mobile station.

Referring to FIG. 7, data representing the output power of the mobile station (hereinafter referred to as an output power indicator) is applied to a switching control signal generator 701, a control signal generator 702, and a gain control signal generator 703. The output power of the mobile station can be determined by the RSSI of a signal received from a base station or a power control command received from the base station.

Upon receipt of the output power indicator, the switching control signal generator 701 generates the switching control signal SW_2_3. The switching control signal is used to activate the first and second power amplifiers 307 and 308. The amplification control signal generator 702 generates the amplification control signal PA_R based on the output power indicator to adjust a control voltage applied to the power amplifiers 307 and 308. The gain control signal generator 703 generates control data based on the output power indicator to control the AGC amplifier 302. A PDM (Pulse Density Modulator) 704 modulates the control data received from the gain control signal generator 703 in a PDM(Pulse Density Modulation) format and, then outputs the gain control signal TX_AJC_ADJ to the AGC amplifier 302.

As described above, the switching control signal SW_2_3 indicating a low power state or a high power state is generated on the basis of the transmission power of the mobile station calculated with reception power. The switching control signal exhibits a hysteresis characteristic as shown in FIG. 9. It is noted from FIG. 9 that the switching control signal has such a characteristic that prevents the performance of the mobile station from being deteriorated due to frequent switching in the vicinity of switching power. The switching control signal is used to switch the switch 305 and selectively activate the first and second power amplifiers 307 and 308.

FIG. 4 is a block diagram of a transmitting device in a mobile station according to another embodiment of the present invention. The transmitting device is the same in configuration and function as the transmitting device according to the first embodiment of

- 8 -

the present invention, except that the switch 305 is replaced by a first circulator 405.

Referring to FIG. 4, a controller 401 provides overall control to the mobile station. In particular, the controller 401 feeds the gain control signal TX_AGC_ADJ to an AGC amplifier 402, the amplification control signal PA_R [1:0] to a control circuit 406, and the switching control signal SW_2_3 to a first power amplifier 407 and a second power amplifier 408.

The AGC amplifier 402 controls the gain of an input signal to a corresponding level based on the gain control signal. A mixer 403 mixes the output of the AGC amplifier 402 with a local signal generated from a local oscillator (not shown), for frequency conversion which increases the frequency of the output of the AGC amplifier 402. A driving amplifier 404 amplifies the output of the mixer 403. The control circuit 406 outputs a control voltage for controlling the first power amplifier 407 in response to the amplification control signal.

The first circulator 405 has a first port 1 connected to the output port of the driving amplifier 404, a second port 2 connected to the input port of the first power amplifier 407, and a third port 3 connected to the input port of the second power amplifier 408. In the low power state, the switching control signal deactivates the first power amplifier 407. Since the first circulator 405 routes an input signal in the direction of 1-2-3-1, the output of the driving amplifier 404 is connected to the second port of the first circulator 405. However, the deactivation of the first power amplifier 407 connected to the second port of the first circulator 405 brings about reflection of almost all power of the input signal so that the output of the driving amplifier 404 is consequently transmitted to the second power amplifier 408.

On the other hand, in the high power state, the switching control signal deactivates the second power amplifier 408. The first circulator 405 connects the output of the driving amplifier 404 received through the first port to the first power amplifier 407 through the second port.

The first and second power amplifiers 407 and 408 amplify the signal received from the first circulator 405. A second circulator 409 has a first port 1 connected to the first power amplifier 407, a third port 3 connected to the second power amplifier 408, and a second port 2 connected to a duplexer (not shown). The second circulator 409 selectively

- 9 -

transmits the outputs of the first and second power amplifiers 407 and 408 to the duplexer in accordance with the power level

5 When the mobile station is placed in the low power state, since the first power amplifier 407 is deactivated, the second power amplifier 408 amplifies the RF signal output from the driving amplifier 404 and the amplified signal is transmitted to the duplexer through the second circulator 409. On the other hand, in the high power state, since the second power amplifier 408 is deactivated, the RF signal is power-amplified in the first power amplifier 407 and transmitted to the duplexer through the second circulator
10 409.

The third port 3 of the first circulator 405 may be connected directly to the third port 3 of the second circulator 409 without interposing the second power amplifier 408. This implies that the mobile station transmits data in the low power state without power
15 amplification.

FIG. 5 is a block diagram of a transmitting device in a mobile station according to a third embodiment of the present invention. This transmitting device is characterized in that a circulator is connected to the output port of each power amplifier.
20

Referring to FIG. 5, a controller 501 provides overall control to the mobile station. In particular, the controller 501 feeds the gain control signal TX_AGC_ADJ to an AGC amplifier 502, the amplification control signal PA_R [1:0] to a control circuit 506, and the switching control signal SW_2_3 to a switch 505, a first power amplifier 507, and a
25 second power amplifier 508.

The AGC amplifier 502 controls the gain of an input signal to a corresponding level in response to the gain control signal. A mixer 503 mixes the output of the AGC amplifier 502 with a local signal generated from a local oscillator (not shown), for
30 frequency conversion which increases the frequency of the output of the AGC amplifier 502. A driving amplifier 504 amplifies the output of the mixer 503. The control circuit 506 outputs a control voltage for controlling the first power amplifier 507 based on the amplification control signal.

35 The switch 505 has a common port 1 connected to the output port of the driving

- 10 -

amplifier 504, a first output port 2 connected to the input port of the first power amplifier 507, and a second output port 3 connected to the input port of the second power amplifier 508. The switch 505 switches the RF signal received from the driving amplifier 504 to the first or second power amplifier 507 or 508 according to the switching control signal SW_2_3 received from the controller 501. The first and second power amplifiers 507 and 508 amplify the power of the RF signal received from the switch 505.

A first circulator 509 has a first port 1 connected to the output port of the first power amplifier 507 and a second port 2 connected to a duplexer (not shown). Thus the first circulator 509 connects the output of the first power amplifier 507 received through the first port to the duplexer through the second port. A second circulator 510 has a first port 1 connected to the second power amplifier 508 and a second port 2 connected to the duplexer. Thus, the second circulator 510 connects the output of the second power amplifier 508 received through the first port to the second duplexer through the second port. A circulator may be used instead of the switch 505.

FIG. 6 is a block diagram of a transmitting device in a mobile station according to a fourth embodiment of the present invention. This transmitting device maximizes the efficiency of power amplifiers through control of bias current and bias voltage, as compared to the transmitting devices according to the first to third embodiments of the present invention. For details of the bias current and voltage control, see Korea Application No. 98-23776.

Referring to FIG. 6, a controller 601 provides overall control to the mobile station. In particular, the controller 601 transmits the gain control signal TX_AGC_ADJ to an AGC amplifier 602, , and a switching control signal SW_2_3 to a first power amplifier 607 and a second power amplifier 608. Also, the controller 601 outputs a first control signal to a voltage control circuit 610 to control bias voltages applied to the power amplifiers 607 and 608, and a second control signal to a current control circuit 611 to control bias currents applied to the power amplifiers 607 and 608. The AGC amplifier 602 controls the gain of an input signal to a corresponding level in response to the gain control signal. A mixer 603 mixes the output of the AGC amplifier 602 with a local signal generated from a local oscillator (not shown), for frequency conversion which increases the frequency of the power of the AGC amplifier 602. A driving amplifier 604 amplifies the output of the mixer 603.

The voltage control circuit 610 outputs a first control voltage based on the first control signal received from the controller 601 to control the bias voltages of the first and second amplifiers 607 and 608. The current control circuit 611 outputs a second control
5 voltage based on the second control signal received from the controller 601 to control the bias current of the first or second power amplifier 607 or 608. The first control voltage is applied to collectors of the power amplifiers 607 and 608 to thereby control collector voltages. The second control voltage is applied to bases of the power amplifiers 607 and
10 608 to thereby control current flowing transistors in the power amplifiers 607 and 608. The first and second control voltages, determined according to the output level of the mobile station, are preset as data in a memory or programmed as a function. Also, the first and second control voltages are set in such a way to obtain maximum efficiency from the power amplifiers according to the strength of an input signal.

15 A first circulator 605 has a first port 1 connected to the output port of the driving amplifier 604, a second port 2 connected to the input port of the first power amplifier 607, and a third port 3 connected to the input port of the second power amplifier 608. A switch can be used instead of the first circulator 605.

20 In the low power state, since the switching control signal deactivates the first power amplifier 607, the first circulator 605 routes the output of the driving amplifier 604 received through the first port to the second power amplifier 608 through the third port. On the other hand, in the high power state, since the switching control signal deactivates the second power amplifier 608, the first circulator 605 routes the output of the driving
25 amplifier 604 received through the first port to the first power amplifier 607 connected to the second port.

The first and second power amplifiers 607 and 608 amplify the signal received from the first circulator 605. Here, bias voltages and bias currents applied to the first and
30 second power amplifiers 607 and 608 are controlled by means of the first and second control voltages generated from the voltage control circuit 610 and the current control circuit 611 so that the first and second power amplifiers 607 and 608 can amplify with maximum efficiency.

35 A second circulator 609 has a first port 1 connected to the first power amplifier

- 12 -

607, a third port 3 connected to the second power amplifier 608, and a second port 2 connected to a duplexer (not shown). The second circulator 609 connects the outputs of the first and second power amplifiers 607 and 608 to the duplexer. In the low power state, since the first power amplifier 607 is deactivated, the second circulator 609 connects the output of the second power amplifier 608 received through the third port to the duplexer through the second port. On the other hand, in the high power state, since the second power amplifier 608 is deactivated, the second circulator 609 connects the output of the first power amplifier 607 received through the first port to the duplexer through the second port.

An isolator may be connected to the output port of each power amplifier instead of the second circulator 609. Also, the third port 3 of the first circulator 605 can be connected directly to the third port 3 of the second circulator 609 without interposing the second power amplifier 608. This implies that the mobile station transmits data in the low power state without power amplification.

FIG. 8 is a block diagram of a control signal generating unit for generating the switching control signal SW_2_3, the first control signal PA_VOL_CNTL for controlling bias voltages of the power amplifiers, the second control signal PA_R [1:0] for controlling bias currents of the power amplifiers, and the gain control signal TX_AGC_ADJ. The control signal generating unit is provided in the controller of the mobile station.

Referring to FIG. 8, an output power indicator is applied to a switching control signal generator 801, a first control signal generator 802, a second control signal generator 803, and a gain control signal generator 804. The output power of the mobile station can be determined by the RSSI of a signal received from a base station or a power control command received from the base station.

Upon receipt of the output power indicator, the switching control signal generator 801 generates the switching control signal SW_2_3 to selectively activate the first or second power amplifier 607 or 608. The first control signal generator 802 generates the first control signal PA_VOL_CNTL based on the output power indicator to control the bias voltages applied to the power amplifiers 607 and 608. The second control signal generator 803 generates the second control signal PA_R [1:0] based on the output power indicator to control the bias currents applied to the power amplifiers 607 and 608. The

- 13 -

gain control signal generator 804 generates control data based on the output power indicator to control the AGC amplifier 602. A PDM 805 modulates the control data received from the gain control signal generator 804 in a PDM format and, then outputs the gain control signal TX_AJC_ADJ to the AGC amplifier 602.

5

Besides the above-described embodiments, it can be further contemplated that a first switching device between a driving amplifier and two power amplifiers is replaced by a circulator, a switch is used as a second switching device between the two power amplifiers and a duplexer, or an isolator is connected to the output port of each power amplifier.

10

As described above, the feature of the present invention lies in selective use of two power amplifiers connected in parallel with different operating characteristics in accordance with the output levels of the mobile station. To minimize possible influence of the output impedance of a deactivated power amplifier on the output port of an activated power amplifier, a circulator is connected to the input/output ports of the power amplifiers.

15

One advantage with the present invention is that the selective use of power amplifiers that maximize efficiency according to output levels of a mobile station reduces the power consumption of the mobile station. Another advantage is that the output impedance of each power amplifier has minimal influence on a matching circuit at the output port of the other power amplifier by connecting a circulator to the output ports of the parallel connected power amplifiers.

20

While the invention has been shown and described with reference to certain preferred embodiments thereof, it will be understood by those skilled in the art that various changes in form and details may be made therein without departing from the spirit and scope of the invention. For example, the present invention is not limited to two power amplifiers as described. Therefore, the scope of the invention is defined by the appended claims.

25

30

WHAT IS CLAIMED IS:

1. A mobile station device comprising:
 - a first power amplifier having high efficiency when an output power level of a mobile station is high;
 - a second power amplifier having high efficiency when the output power level is low;
 - a first switch for switching a radio frequency (RF) signal to one of the two power amplifiers;
 - a second switch coupled to outputs of the two amplifiers for connecting the output of one of the two amplifiers receiving the RF signal to a duplexer, said second switch isolating the output of the amplifier not receiving the RF signal from the output of the amplifier receiving the RF signal ; and
 - a controller for selectively activating one of the two power amplifiers according to the output power level associated with the radio frequency signal.
2. The mobile station device of claim 1, wherein the first switch is a circulator.
3. The mobile station device of claim 1, wherein the first switch is an isolator.
4. The mobile station device of claim 1, wherein the second switch is a circulator.
5. The mobile station device of claim 1, wherein the second switch is an isolator.
6. A mobile station device comprising:
 - power amplifiers for amplifying the power of an input RF signal with different operation characteristics regarding a power level;
 - a first switch for switching selectively the RF signal to the corresponding power amplifiers according to the output power level of the mobile; and
 - a second switch coupled to outputs of the power amplifiers for connecting the output of one of the amplifiers receiving the RF signal to a duplexer, said second switch

isolating the output of the amplifier not receiving the RF signal from the output of the amplifier receiving the RF signal.

7. The mobile station device of claim 6, further comprising a controller for controlling the switching operation of the first switch according to an output power level associated with the radio frequency signal .

8. A mobile station device comprising:

a first power amplifier having high efficiency when an output power level of a mobile station is high;

a second power amplifier having high efficiency when the output power level is low;

a controller for selectively activating one of the two power amplifiers according to the output power level associated with the radio frequency signal ;

a control circuit for providing a first control voltage and a second control voltage according to the output power level to the two power amplifiers to control bias voltage and bias current applied to the power amplifiers;

a first switch for switching an RF signal to an activated power amplifier of the two power amplifiers; and

a second switch coupled to outputs of the two amplifiers for connecting the output of one of the two amplifiers receiving the RF signal to a duplexer, said second switch isolating the output of the amplifier not receiving the RF signal from the output of the amplifier receiving the RF signal .

9. The mobile station device of claim 8, wherein the output power level of the mobile station is determined by the strength of a signal received from a base station.

10. The mobile station device of claim 9, wherein the first switch is a circulator.

11. The mobile station device of claim 9, wherein the second switch is a circulator.

12. A mobile station device comprising:

an automatic gain control (AGC) amplifier for controlling gain of an input signal based on a gain control signal;

a mixer for converting a gain-controlled signal received from the AGC amplifier

- 16 -

to an RF signal;

a driving amplifier for amplifying the RF signal received from the mixer;

a first power amplifier having high efficiency when an output power level of a mobile station is high;

5 a second power amplifier having high efficiency when the output power level is low;

a controller for selectively activating the one of the two power amplifiers according to the output power level associated with the radio frequency signal ;

10 a first switch for switching the amplified RF signal received from the driving amplifier to an activated power amplifier of the two power amplifiers; and

a second switch coupled to outputs of the two amplifiers for connecting the output of one of the two amplifiers receiving the RF signal to a duplexer, said second switch isolating the output of the amplifier not receiving the RF signal from the output of the amplifier receiving the RF signal.

15

13. The mobile station device of claim 12, further comprising a control circuit for providing a first control voltage and a second control voltage according to the output power level to the two power amplifiers to control bias voltage and bias current applied to the power amplifiers.

20

14. The mobile station device of claim 13, wherein the first switch is a circulator.

25

15. The mobile station device of claim 14, wherein the second switch is a circulator.

30

16. A method of controlling an output power level of a mobile station that has a first power amplifier having high efficiency when the output power level of the mobile station is high, a second power amplifier having high efficiency when the output power level is low, a switch for switching an RF signal to one of the two power amplifiers, and a circulator for connecting the outputs of the two power amplifiers to a duplexer, the method comprising the steps of;

measuring the strength of a signal received from a base station;

35

determining the output power level of the mobile station based on the signal strength measurement;

- 17 -

activating one of the two power amplifiers according to the determined output level; and

controlling the switch to switch the RF signal to the activated power amplifier.

5 17. The method of claim 16, further comprising the steps of:
determining a first control voltage and a second control voltage according to the
determined output power level to control bias voltages and bias current applied to the two
power amplifiers; and
10 feeding the first and second control voltages to the two power amplifiers.

10 18. A method of controlling an output power level of a mobile station
having an AGC amplifier for controlling the gain of an input signal based on a gain
control signal, a mixer for converting a gain-controlled signal received from the AGC
amplifier to an RF signal, a driving amplifier for amplifying the RF signal received from
15 the mixer, a first power amplifier having high efficiency when the output power level of
the mobile station is high, and a second power amplifier having high efficiency when the
output power level of the mobile station is low, the method comprising the steps of;
measuring the strength of a signal received from a base station;
determining the output power level of the mobile station based on the signal
20 strength measurement;
activating one of the two power amplifiers according to the determined output
level; and
feeding the RF signal output from the driving power amplifier to the activated
power amplifier.

25 19. The method of claim 18, further comprising the steps of:
determining a first control voltage and a second control voltage according to the
determined output power level to control bias voltages and bias current applied to the two
power amplifiers; and
30 feeding the first and second control voltages to the two power amplifiers.

20. The method of claim 19, further comprising the step of transmitting a
signal amplified by the activated power amplifier through a duplexer.

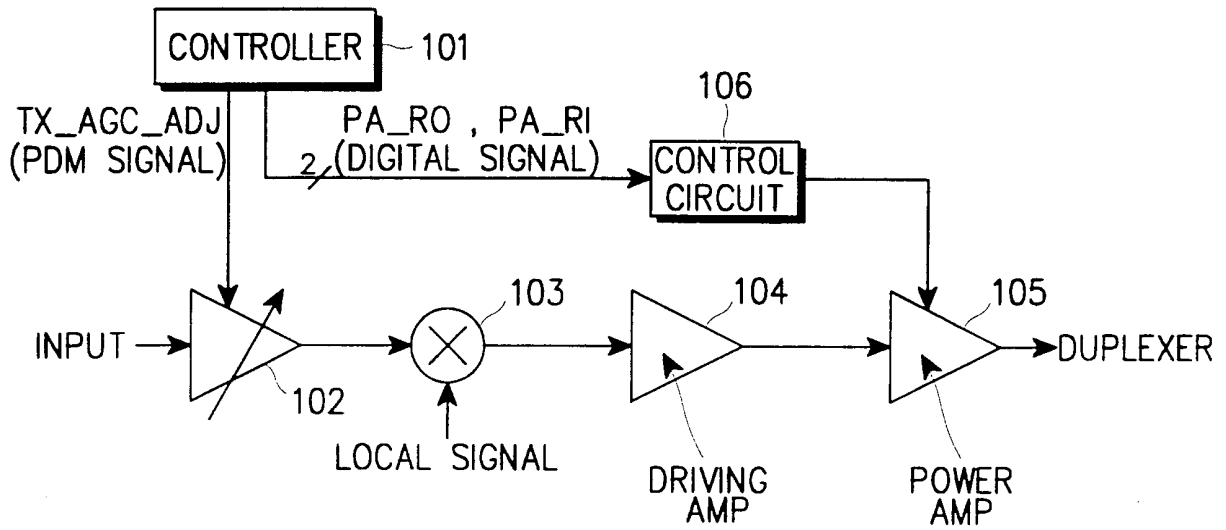

FIG. 1

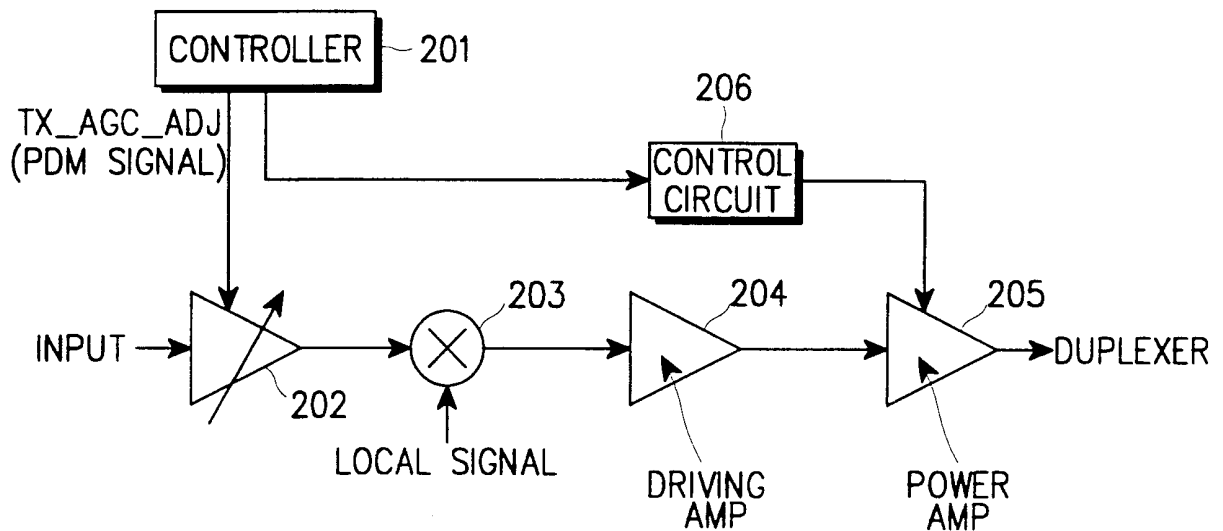

FIG. 2

FIG. 3

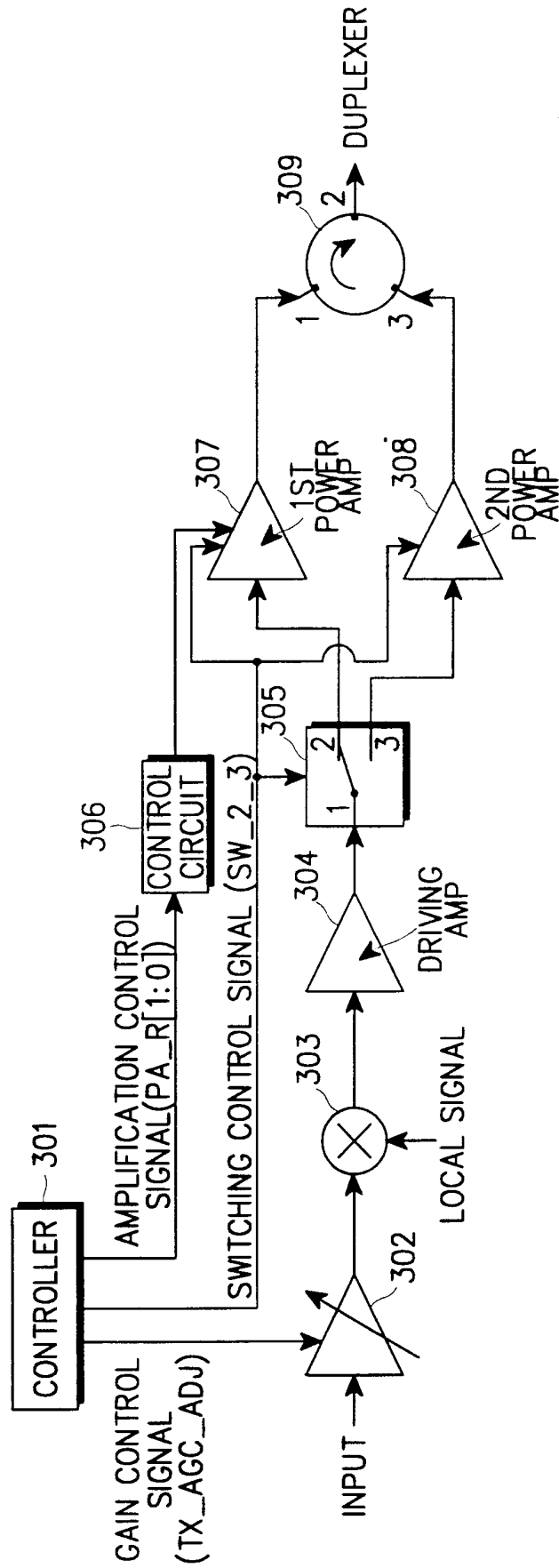

FIG. 4

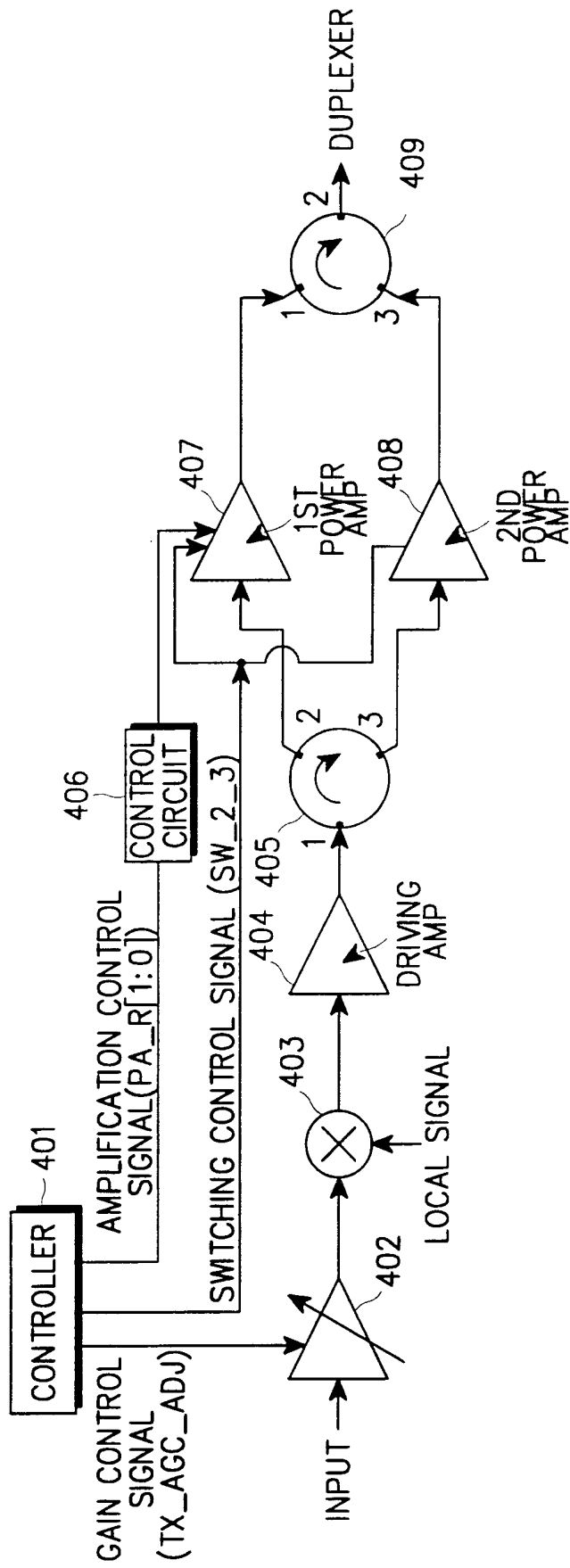

FIG. 5

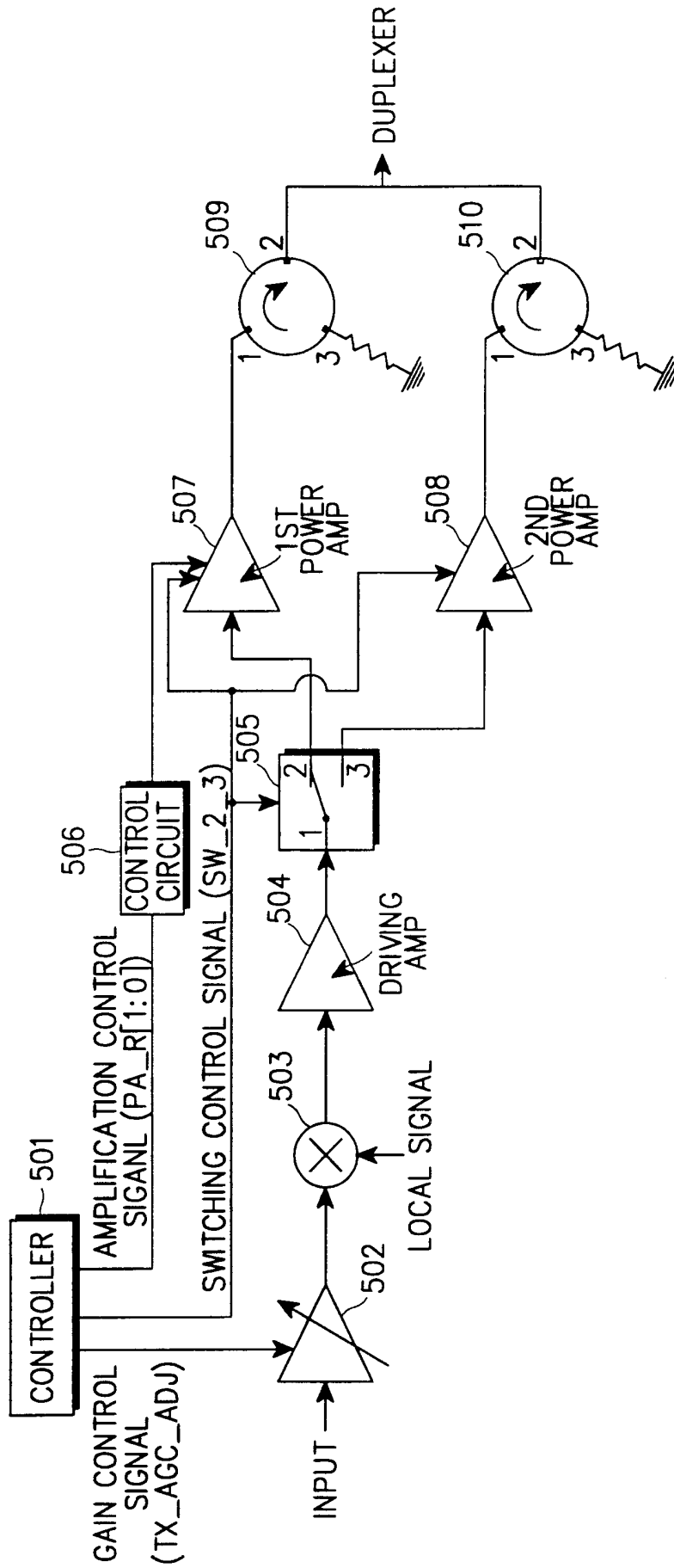
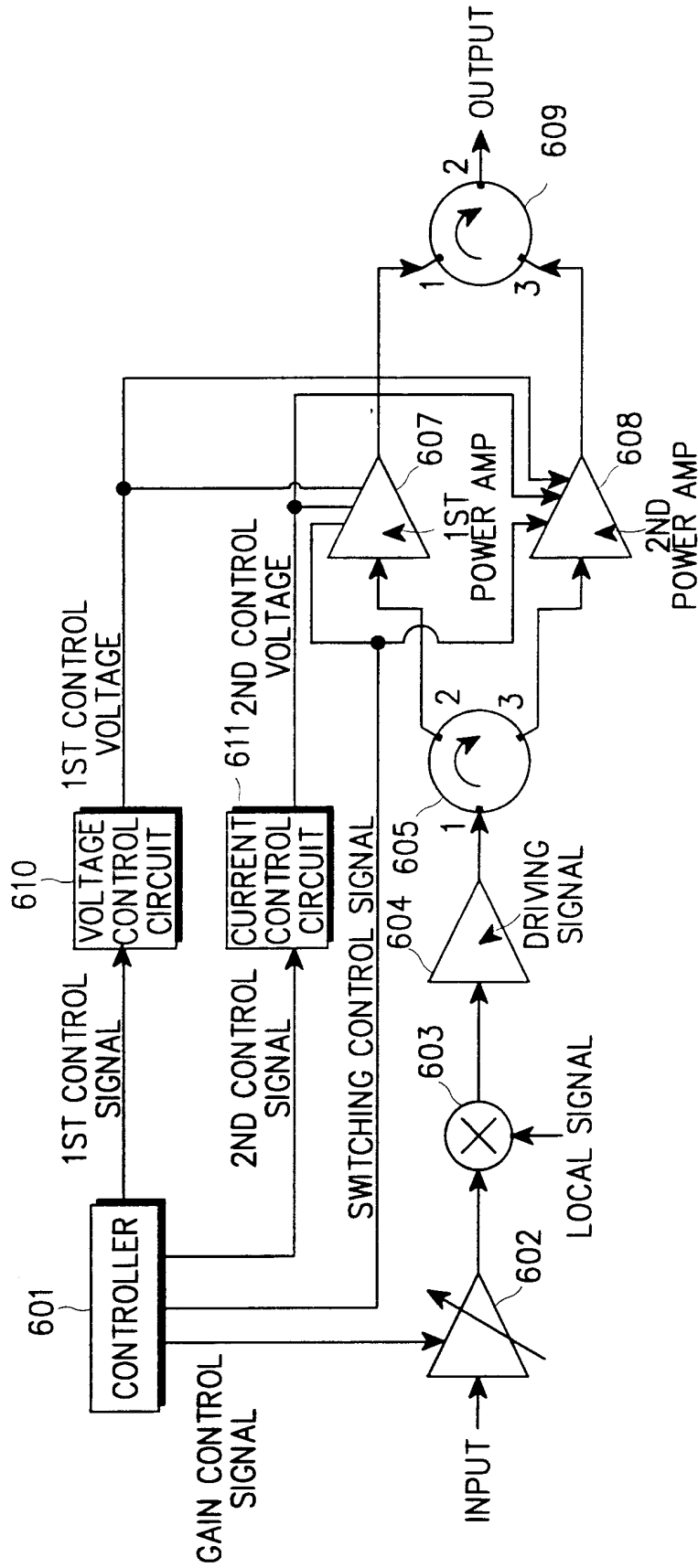

FIG. 6



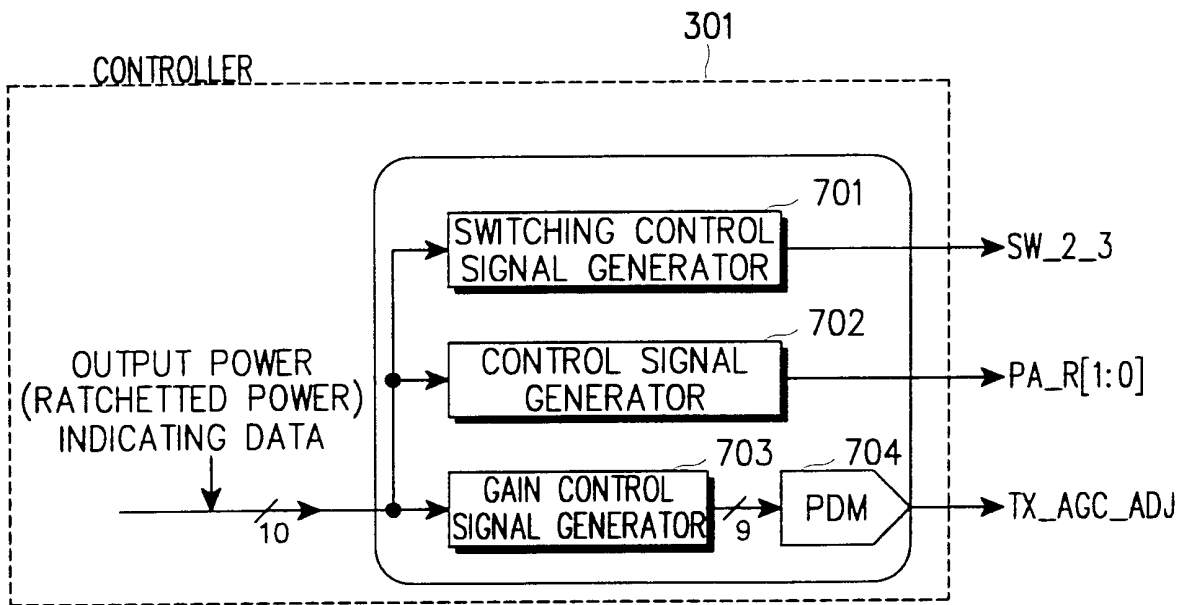
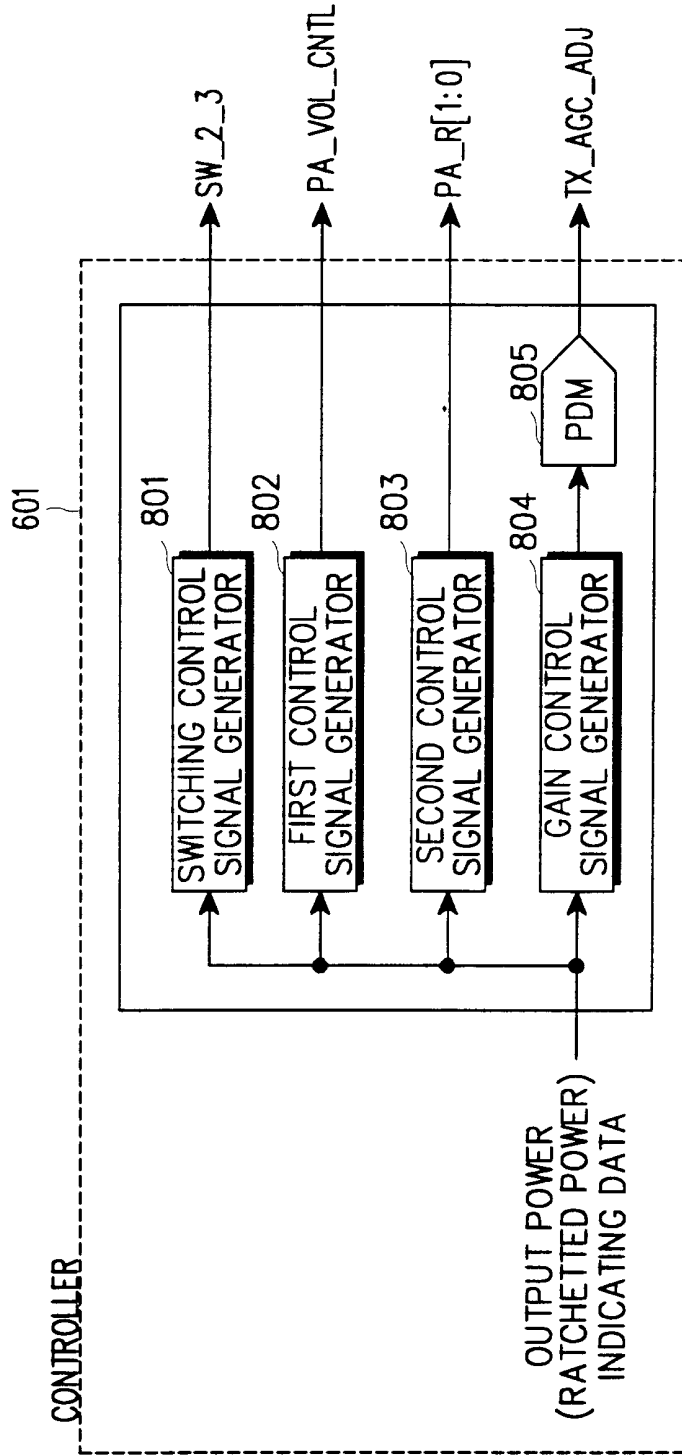

FIG. 7

FIG. 8



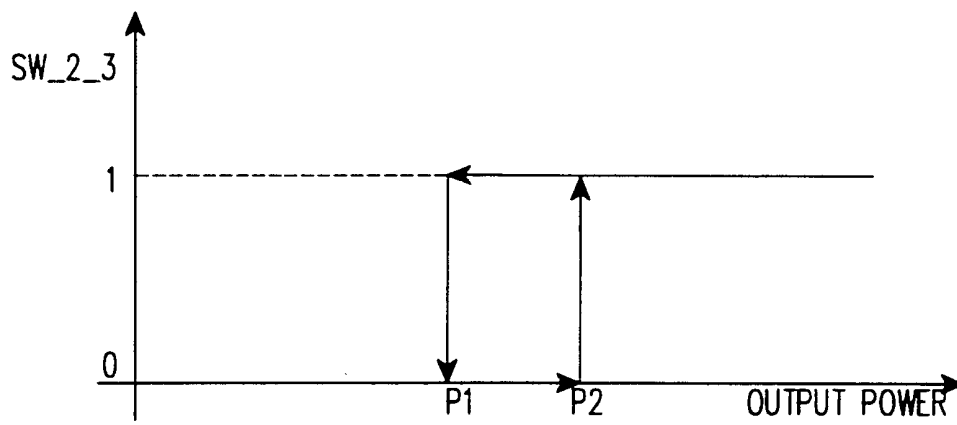

FIG. 9

INTERNATIONAL SEARCH REPORT

international application No.

PCT/KR00/01212

A. CLASSIFICATION OF SUBJECT MATTER**IPC7 H04B 1/40**

According to International Patent Classification (IPC) or to both national classification and IPC

B. FIELDS SEARCHED

Minimum documentation searched (classification system followed by classification symbols)

IPC 7 H04B 1/40, H04B 7/26, H03G 3/00

Documentation searched other than minimum documentation to the extent that such documents are included in the fields searched

Korean Patents and applications for inventions since 1975, Korean Utility models and applications for Utility models since 1975

Japanese Patents and applications for inventions since 1975

Electronic data base consulted during the international search (name of data base and, where practicable, search terms used)

C. DOCUMENTS CONSIDERED TO BE RELEVANT

Category*	Citation of document, with indication, where appropriate, of the relevant passages	Relevant to claim No.
Y	EP 853391 A (LUCENT TECHNOLOGIES INC.) 6 JAN. 1998, see entire document, figure 3	1,6,8,12,16,18
A	JP 5-284083 A (NEC CORP.) 29 OCT. 1993, see abstract and figure 1	1,6,8,12
A	KR 91-7654 B (JAE-IK, JUNG) 28 SEP. 1991, see abstract	1,6,8,12
A	KR 152002 B (SAMSUNG ELECTRIC CORP.) 24 JUN 1998, see abstract and figure 2	1,6,8,12

 Further documents are listed in the continuation of Box C. See patent family annex.

* Special categories of cited documents:

"A" document defining the general state of the art which is not considered to be of particular relevance

"E" earlier application or patent but published on or after the international filing date

"L" document which may throw doubts on priority claim(s) or which is cited to establish the publication date of citation or other special reason (as specified)

"O" document referring to an oral disclosure, use, exhibition or other means

"P" document published prior to the international filing date but later than the priority date claimed

"T" later document published after the international filing date or priority date and not in conflict with the application but cited to understand the principle or theory underlying the invention

"X" document of particular relevance; the claimed invention cannot be considered novel or cannot be considered to involve an inventive step when the document is taken alone

"Y" document of particular relevance; the claimed invention cannot be considered to involve an inventive step when the document is combined with one or more other such documents, such combination being obvious to a person skilled in the art

"&" document member of the same patent family

Date of the actual completion of the international search

09 FEBRUARY 2001 (09.02.2001)

Date of mailing of the international search report

12 FEBRUARY 2001 (12.02.2001)

Name and mailing address of the ISA/KR

Korean Industrial Property Office
Government Complex-Taejon, Dunsan-dong, So-ku, Taejon
Metropolitan City 302-701, Republic of Korea

Facsimile No. 82-42-472-7140

Authorized officer

KIM, Choon Seok

Telephone No. 82-42-481-5947



INTERNATIONAL SEARCH REPORT

Information on patent family members

International application No.

PCT/KR00/01212

Patent document cited in search report	Publication date	Patent family member(s)	Publication date
EP 833391 A	15.07.1998	JP 10242781 A	11.09.1998
JP 5-284083 A	29.10.1993	AU 1733992 A CA 2070027 A DE 69215 C EP 516453 A KR 9609926 B	03.12.1993 01.12.1992 19.12.1996 02.12.1992 24.07.1996
KR 91-7654 B	28.09.1991	NONE	
KR 152002 B	24.06.1998	NONE	