

July 31, 1956

G. HILL

2,756,891

TOP LABELING MACHINE

Filed May 21, 1953

4 Sheets-Sheet 1

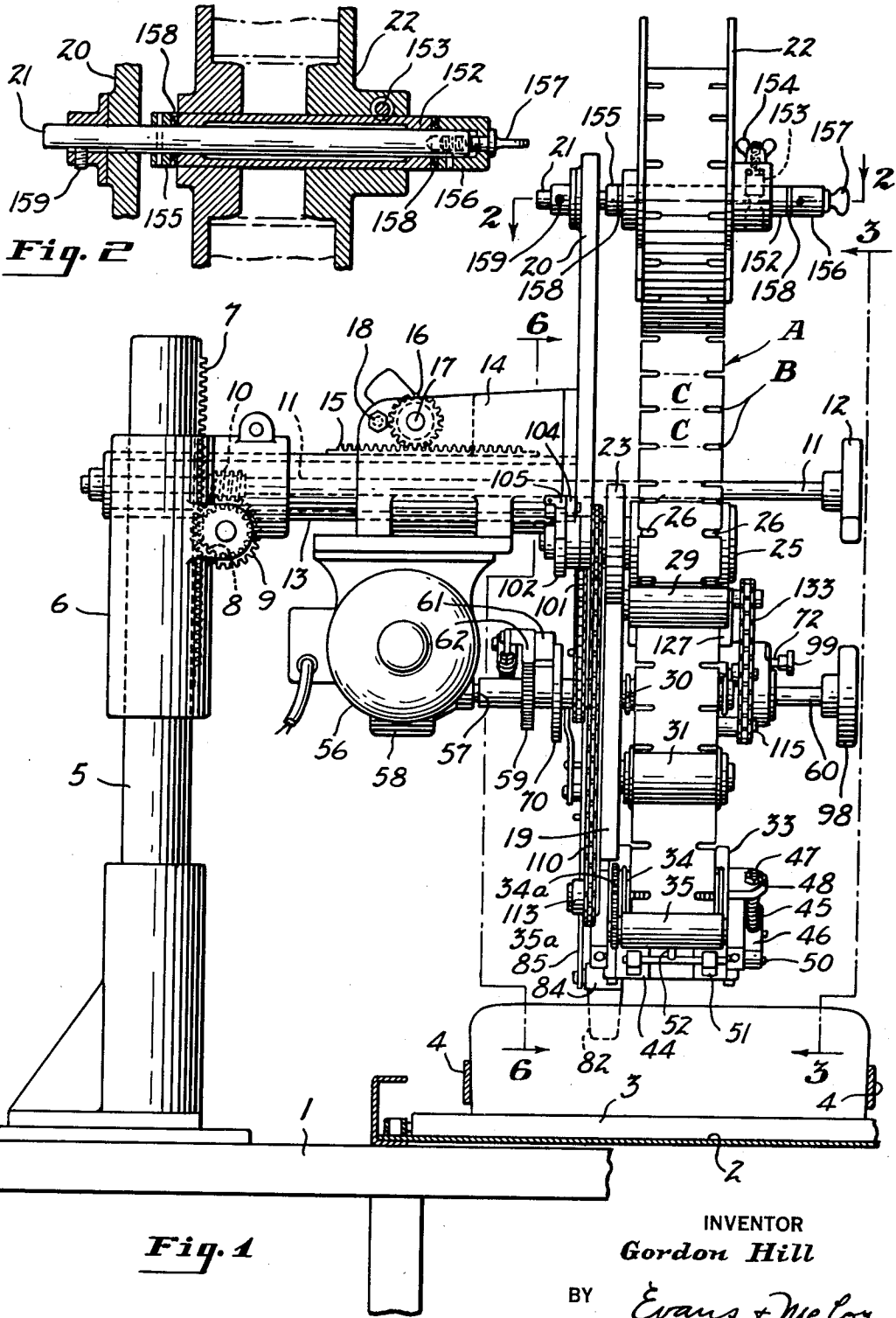

Fig. 1

INVENTOR
Gordon Hill

BY Evans + Me Loy
ATTORNEYS

July 31, 1956

G. HILL

2,756,891

TOP LABELING MACHINE

Filed May 21, 1953

4 Sheets-Sheet 2

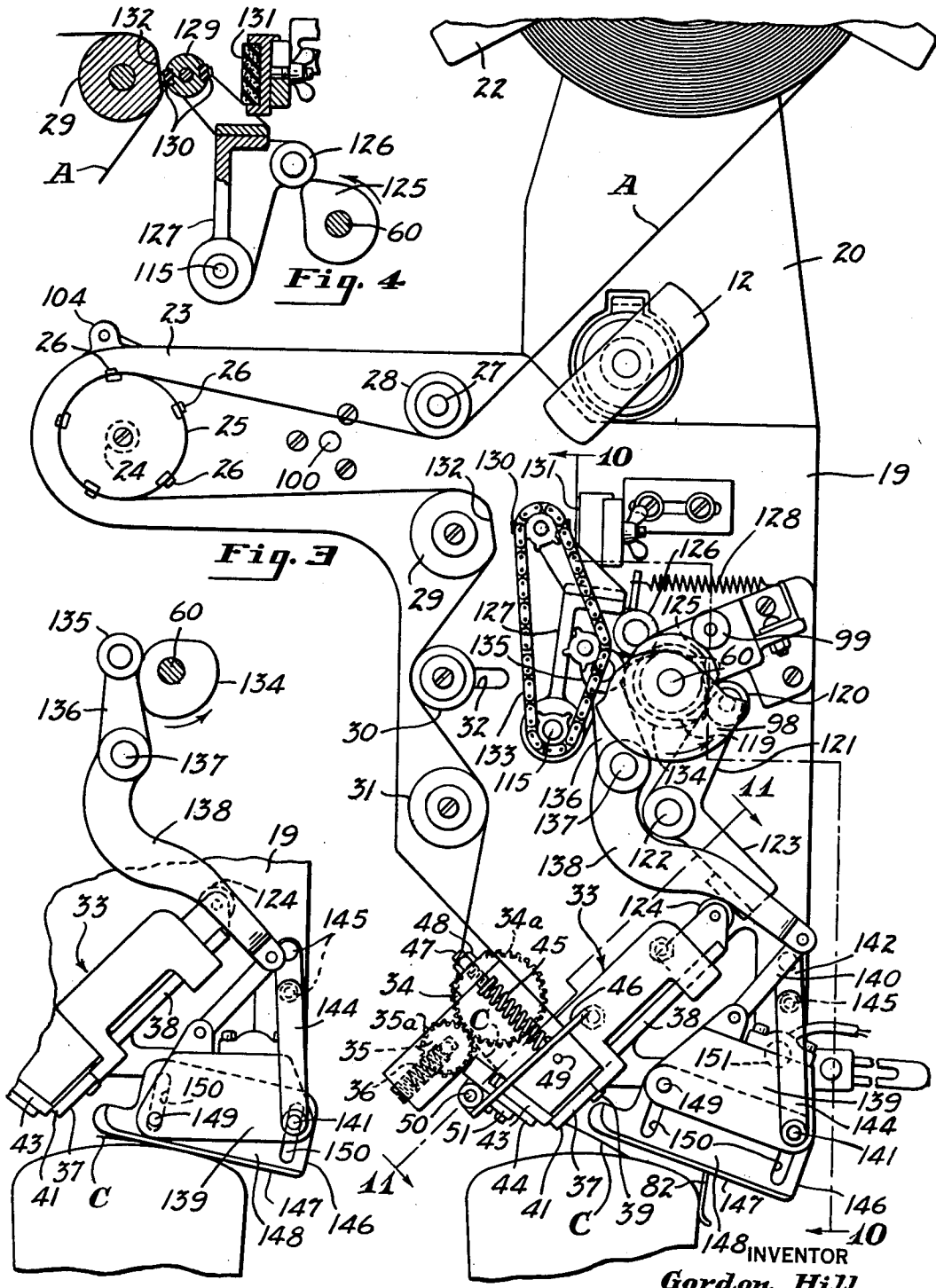

Fig. 4

Fig. 3

Fig. 5

INVENTOR
Gordon Hill
 BY *Evans + Mc Coy*
 ATTORNEYS

July 31, 1956

G. HILL

2,756,891

TOP LABELING MACHINE

Filed May 21, 1953

4 Sheets-Sheet 3

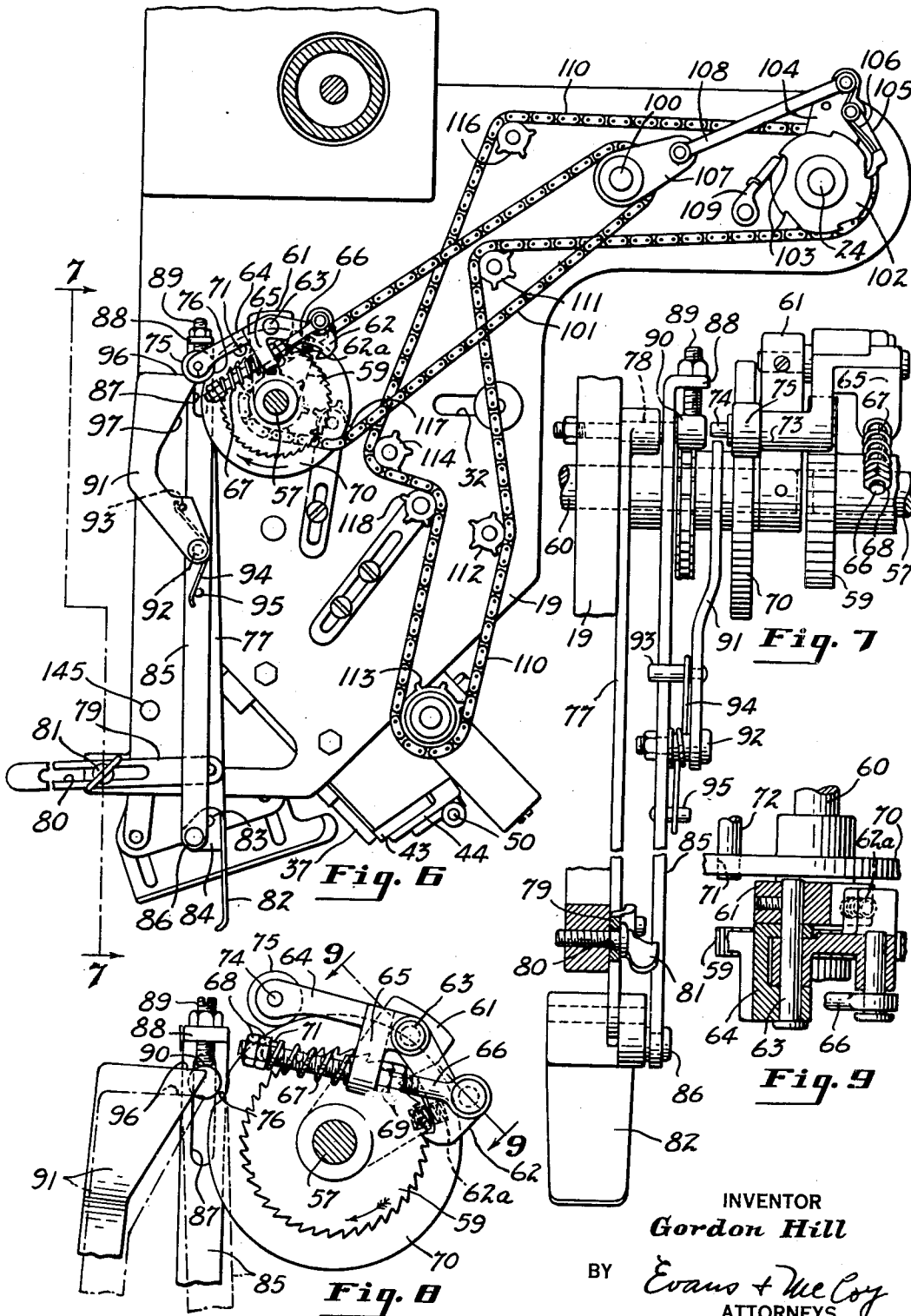

INVENTOR
Gordon Hill

BY Evans & Mc Coy
ATTORNEYS

July 31, 1956

G. HILL

2,756,891

TOP LABELING MACHINE

Filed May 21, 1953

4 Sheets-Sheet 4

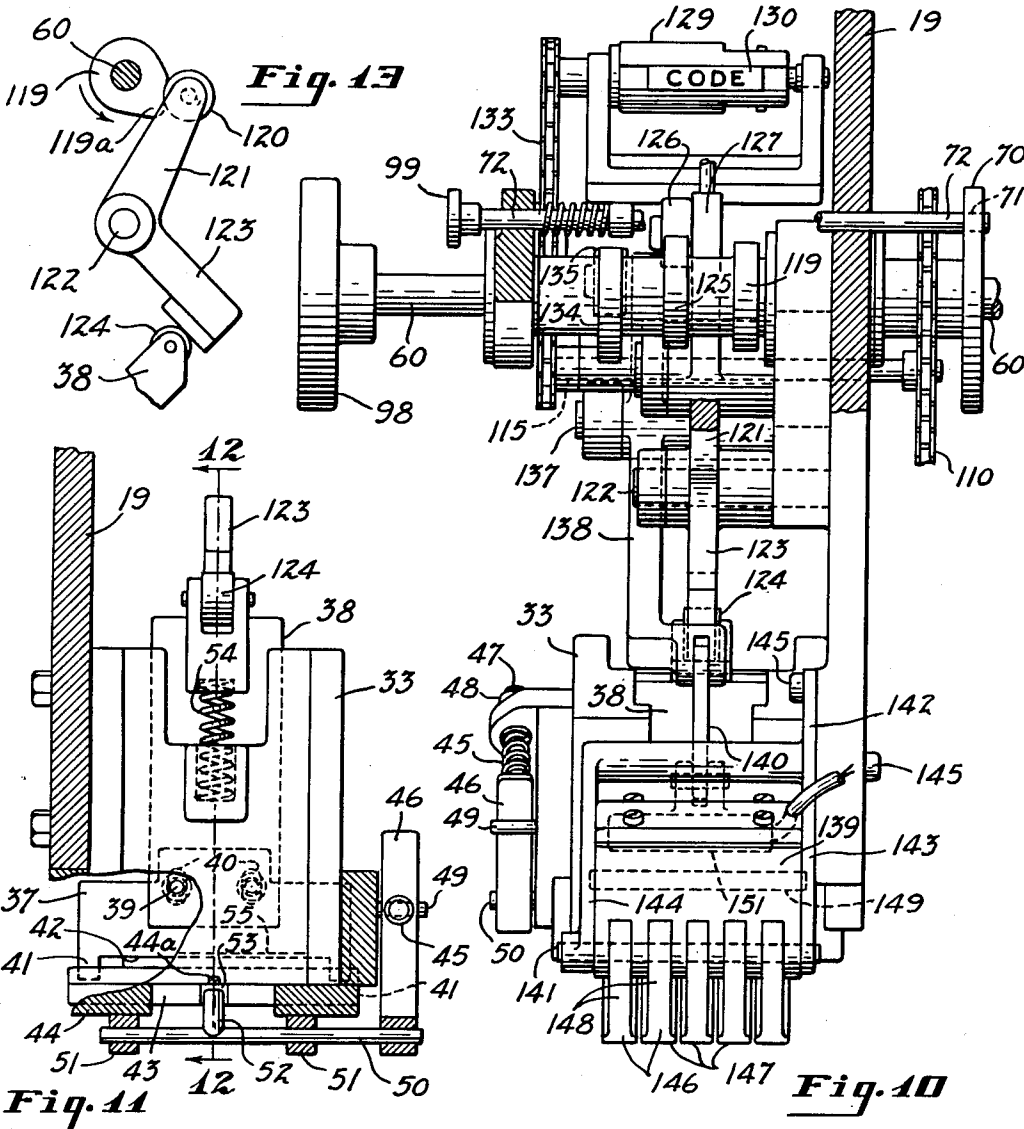

Fig. 11

Fig. 10

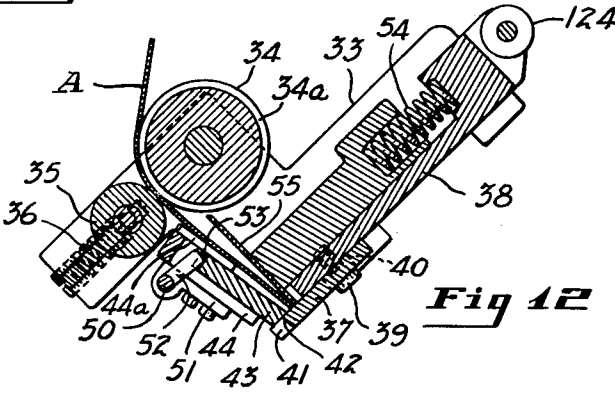

Fig. 12

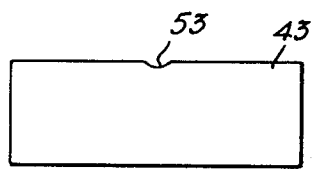

Fig. 14

INVENTOR
Gordon Hill

BY Evans & McCoy
ATTORNEYS

1

2,756,891

TOP LABELING MACHINE

Gordon Hill, Bettendorf, Iowa, assignor, by mesne assignments, to American Machine & Foundry Company, New York, N. Y., a corporation of New Jersey

Application May 21, 1953, Serial No. 356,408

12 Claims. (Cl. 216—22)

This invention relates to labeling machines and more particularly to a machine for applying labels to the top faces of articles that are being carried beneath the labeling mechanism by a continuously moving conveyor.

The labeling machine of the present invention is supported directly over a conveyor for moving the articles to be labeled and is adjustable vertically and transversely with respect to the conveyor to accommodate articles of different heights and to place the labels on the articles in the desired position intermediate the ends of the articles. A strip of labels is fed from a roll to the label applying means, one label length at a time, and a cutter for severing the labels is provided adjacent the label applying means. During each cycle of the labeling mechanism a label is severed from the leading end of the label strip and applied to an article on the conveyor and the label strip is advanced one label length to position the next label for application to an article. The labeling mechanism is so controlled by articles on the conveyor that it performs a complete cycle of operations to apply a label to each package as it is moved past the label applying means by the conveyor.

The labeling mechanism and the article conveyor are preferably independently driven and the labeling mechanism is operated by a continuously rotating driving shaft in such manner that a complete cycle of operations is performed during one revolution of an actuator shaft that is automatically disconnected from the driving shaft after it has completed one revolution. The driving connection is established between the driving shaft and the actuating shaft by means of a trip in the path of articles on the conveyor and the proper timing of the labeling mechanism with respect to the movement of articles by the conveyor is obtained by adjusting the trip longitudinally of the conveyor.

To facilitate adjustment, the trip lever is mounted on a member that is pivotally suspended to swing about a horizontal axis that is transverse to the linear path of travel of the articles to be labeled. The trip supporting member may be secured in various adjusted positions and carries clutch actuating members that are operated by the trip lever in any adjusted position of the support.

In the cycle of operation performed during one revolution of the actuator shaft the means for severing a label from the label strip and the means for applying the severed label to the article are operated during the initial portion of the operating cycle, after which the label feed mechanism is operated to advance the label strip one label length to deliver a label to article engaging position so that it can be severed from the label strip and applied to the next article that engages the trip.

The labeling mechanism may include a printing mechanism that is operated during each cycle of operation of the labeling mechanism to print upon a label during the portion of the operating cycle during which a label strip is held stationary.

The invention has for an object to provide a labeling

2

mechanism that is driven independently of the conveyor that advances the articles to be labeled and in which the proper timing of the labeling mechanism can be obtained by adjustment of an article actuated trip member.

5 A further object is to provide a mechanical connection between the adjustable trip member and the controlling clutch that is operative in all adjusted positions of the trip.

10 Additional objects are to provide an improved label severing mechanism, an improved label applying mechanism, an improved label feed mechanism and an improved printing attachment.

Reference should be had to the accompanying drawings forming a part of this specification in which:

15 Figure 1 is a vertical section showing the labeling mechanism in rear elevation looking in the direction of article movement;

20 Fig. 2 is a fragmentary horizontal section through the strip supporting reel taken on the line indicated at 2—2 in Fig. 1;

Fig. 3 is a side elevation of the labeling mechanism viewed as indicated by the arrows 3—3 in Fig. 1;

25 Fig. 4 is a fragmentary sectional view showing the printing mechanism;

30 Fig. 5 is a fragmentary side elevation of the label severing and label applying means showing the label ironing members in engagement with a label on an article passing beneath them;

35 Fig. 6 is a vertical section taken on the line indicated at 6—6 in Fig. 1, showing the clutch members disengaged;

Fig. 7 is a vertical section taken on the line indicated at 7—7 in Fig. 6;

40 Fig. 8 is a fragmentary sectional view showing the clutch mechanism on a larger scale than in Fig. 6 and with the clutch members in engagement;

45 Fig. 9 is a fragmentary section taken on the line indicated at 9—9 in Fig. 8;

Fig. 10 is a vertical section taken on the broken line indicated at 10—10 in Fig. 3;

50 Fig. 11 is a fragmentary section taken on the line indicated at 11—11 in Fig. 3;

55 Fig. 12 is a section taken on the line indicated at 12—12 in Fig. 11;

60 Fig. 13 is a fragmentary view showing the cutter actuating lever and its actuating cam; and

65 Fig. 14 is a plan view of the quick detachable label strip supporting cutter blade.

In the accompanying drawings a labeling machine is shown mounted on a suitable supporting frame 1 upon which a horizontal conveyor is provided for moving the articles to be labeled one at a time beneath the label applying mechanism. As herein shown a horizontal bed 2 is provided along which the articles are moved one at a time by pusher flights 3. Above the bed 2 suitable longitudinal guides 4 are provided for constraining the article to movement in a linear path.

The labeling mechanism is mounted upon a suitable post or standard 5 carried by the frame 1. The standard 5 has a vertically movable slide 6 thereon that can be raised or lowered by suitable means such as a rack 7 on the standard 5 and a pinion 8 carried by the slide 6 and meshing with the rack 7. The pinion 8 is actuated and locked in its various adjusted positions by means of a worm gear 9 and a worm 10 on a horizontal shaft 11 that extends to the front of the machine where it is provided with a handle 12 for convenient manual operation. The slide 6 has a horizontal tubular arm 13 attached thereto that extends laterally toward the conveyor 3 and that carries a slide 14 in the form of a split sleeve that fits upon the arm 13 and that can be adjusted toward and away from the standard 5 by means of a rack

3

15 on the arm 13 and a manually operated pinion 16 carried by a shaft 17 journaled in the slide 14. The slide 14 is secured in adjusted position on the arm 13 by suitable means such as a clamping bolt 18. The slide 14 carries at its outer end a vertically disposed plate 19 5 that provides a support for the labeling mechanism. The plate 19 has a vertical extension 20 that supports a horizontal shaft 21 upon which a label strip reel 22 may be mounted. The plate 19 also has a horizontal extension 10 23 that supports a horizontal shaft 24 upon which a label feed drum 25 is mounted.

A label strip A carried by the reel 22 has regularly spaced notches B on opposite sides thereof that are transversely aligned and disposed between successive labels C. The label feed drum 25 is provided with pairs of projecting lugs 26 that engage in the notches B to prevent slippage of the label strip with respect to the feed drum and that are adjustable axially on the drum periphery to accommodate notches B of different depths. Adjacent 20 the inner end thereof the extension 23 carries a horizontal shaft 27 which supports a guide roller 28 beneath the reel 22 to the feed drum 25. As best shown in Fig. 3, a stationary guide block 29 and guide rollers 30 and 31 are 25 mounted below the roller 28 in substantial vertical alignment therewith to guide the label strip downwardly from the drum 25 toward the article conveyor. The roller 30 is adjustably mounted in a horizontal slot 32 of the plate 19 to advance or retract the leading end of the label strip with respect to the label severing and applying means 30 hereinafter described.

A cutter frame 33 is detachably secured to the lower end portion of the plate 19 and carries a pair of feed rollers 34 and 35 which grip the label strip between them. The roller 35 is yieldingly pressed toward the 35 roller 34 by means of springs 36 and the two rollers are geared together for rotation at equal peripheral speeds by intermeshing gears 34a and 35a.

For severing labels from the leading end of the label strip, the cutter frame 33 is provided with a cutter blade 40 37 that is attached to the lower end of a slide 38 mounted in the frame 33 as best shown in Figs. 11 and 12, the cutter blade being adjustably and detachably secured to the rear face of the slide 38 by screws 39 passing through vertical slots 40 in the blade. Since the blade 37 is 45 attached to the outer face of the slide 38 and at the lower end of the supporting frame, the screws 39 are readily accessible and the blade 37 can be quickly and easily attached to or removed from the slide 38. The blade 37 is provided with downwardly extending projections 50 41 at the ends thereof and with a cutting edge 42 extending across the space between the projections 41. At the lower end thereof the frame 33 carries a label strip supporting cutter blade 43 that is slidably 55 mounted in an end crossbar 44 of the frame 33 that is positioned adjacent the bight of the rollers 34 and 35. The blade 43 has a forward edge that bears against the inner face of the blade 37 and is pressed against the blade 37 by a spring 45 that is interposed between a lever arm 46 and an adjustable shouldered abutment screw 47 60 on the frame 33 that is held in adjusted position by means of a nut 48, as best shown in Fig. 3. Movement of the lever arm 46 is limited by a stop pin 49 on the frame 33, the arm 46 being attached to a shaft 50 journaled in brackets 51 attached to the crossbar 44 at the lower end 65 of the cutter frame.

The thrust of the spring 45 is applied to the blade 43 to press it against the blade 37 by a short lever arm 52 attached to the shaft 50 and engaging in a notch 53 in the rear edge of the blade 43 centrally thereof.

One face of the label strip is coated with a wax-like coating of thermoplastic adhesive and this face is on the under side of the strip as it passes over the blade 43. In order to keep the coated face of the label strip out of contact with the blade 43 as much as possible, a narrow

4

strip supporting finger 44a (see Figs. 11 and 12) is attached at its rear end to the bar 44 and extends forwardly over the top face of the blade 43 closely adjacent thereto and centrally thereof, the finger 44a extending far enough toward the blade 37 to normally support the leading end of the strip out of contact with the blade 43.

Since the coated face of the label strip is pressed against the top face of the blade 43 along the forward edges thereof each time that a label is severed from the strip, it is desirable to remove the blade 43 occasionally for cleaning. This can be done by moving the arm 52 rearwardly out of the notch 53, after which the blade 43 can be slid laterally out of the cutter frame, the inner side of the frame being open and readily accessible as shown in Fig. 11.

As best shown in Figs. 11 and 12, a spring 54 normally holds the cutter carrying slide 38 in an elevated position where the cutting edge 42 of the blade 37 is above the blade 43, so that a slot is provided between the projections 41 through which the leading end of the label strip may pass. To insure the passage of the label strip through the slot so formed, a guide plate 55 is provided above the blade 43. In the operation of the machine the label feed drum 25 and the feeding rollers 34 and 35 are operated to advance the label strip one label length during each cycle of operation to advance a label past the cutting edges of the blades 37 and 43 so that a label will be severed from the strip upon actuation of the blade 37.

The labeling mechanism is preferably driven independently of the conveyor 3 by means such as an electric motor 56 mounted on the slide 14 that is adapted to continuously drive a horizontal shaft 57 through suitable reduction gearing in a housing 58 as shown in Fig. 1. The shaft 57 is perpendicular to the plate 19 and parallel to the shafts of the feed drum and feed rollers. The shaft 57 provides a continuously rotating drive shaft for the labeler mechanism and has a ratchet wheel 59 fixed to its outer end. The labeling mechanism is driven by the shaft 57 through an actuator shaft 60 that is journaled in the plate 19 in axial alignment with the shaft 57 as shown in Fig. 7.

A clutch mechanism is provided for connecting the drive shaft 57 to the actuator shaft 60 and for disconnecting the actuator shaft from the drive shaft after completion of each label applying operation. As best shown in Figs. 6 to 9, the shaft 60 has an arm 61 fastened thereto and positioned alongside the ratchet wheel 59 that carries a pawl 62 that overlies the periphery of the ratchet wheel 59 and that is movable radially into and out of engagement with the teeth of the ratchet to releasably connect the shafts 57 and 60 for simultaneous rotation. The pawl 62 is connected to the arm 61 by a horizontal pivot pin 63 and a pawl actuating arm 64 is also pivoted on the pin 63 and is provided with an extension 65 that projects inwardly toward the shaft 57. A rod 66 pivoted at its outer end to the pawl 62 extends through the arm 65. The outer end of the rod 66 attached to the pawl 62 is drawn toward the arm 65 by a spring 67 that is interposed between the arm 65 and a nut 68 at the inner end of the rod 66. A nut 69 on the rod 66 is engageable with the outer face of the arm 65 to limit the inward movement of the rod 66. The spring 67 normally holds the rod 66 in the position where the nut 69 engages the arm 65 so that the actuating arm 64 and the pawl 62 normally have simultaneous movement, but provides a yielding connection which will permit some relative movement between the pawl and actuating arm and prevent jamming if the pawl 62 should be moved into engagement with the top of a ratchet tooth. A spring 62a interposed between the arm 61 and the pawl 62 yieldingly presses the pawl toward its disengaged position.

A circular control disk 70 is loosely mounted on the shaft 60 alongside the pawl carrying arm 61 and this disk

5

is provided with a single aperture 71 that is adapted to receive a locking pin 72 that is slidably mounted in the plate 19 as shown in Figs. 9 and 10 and that serves to hold the disk 70 against turning movements. At the outer end of the actuating arm 64 there is a lateral extension 73 that carries a shaft 74 that overlies the periphery of the disk 70 and that carries a roller 75 that engages the periphery of the disk 70. The disk 70 is of a diameter such that when the roller 75 engages its circular periphery the pawl 62 is held in engagement with the ratchet 59. At one point in its periphery the disk 70 is provided with a notch 76 into which the roller 75 may move and which is of a depth such that the pawl 62 will be disengaged from the ratchet 59 by the spring 62a when the roller 75 engages in the notch 76 as shown in Fig. 6.

To initiate a labeling operation the roller 75 is lifted out of the notch 76, rocking the pawl 62 into engagement with the ratchet 59, whereupon the roller is pulled out of alignment with the notch 76 and into engagement with the circular periphery of the disk 70 which holds the pawl in engagement with the ratchet as shown in Fig. 8, until a complete revolution of the shaft 60 has been effected. When the shaft 60 has turned through a complete revolution the roller 75 reenters the notch 76 in the disk 70, disengaging the pawl 62 from the ratchet.

The shaft 60 during each revolution operates the labeling mechanism to advance the label one label length, to sever the label and to apply it to an article on the conveyor, the operation of the labeling mechanism being initiated by means of a trip mechanism that is operated by the articles as they pass beneath the labeling mechanism. The trip mechanism is carried by a supporting arm 77 that is suspended from a horizontal pivot 78 secured to the plate 19 above and forwardly of the shaft 60 and adjacent the notch 76 in the periphery of the disk 70. The lower end of the arm 77 is positioned below and forwardly of the cutter frame 33 and is adjustable longitudinally of the conveyor by means of a link 79 pivoted to the arm 77 and having an elongated slot 80 that receives a clamping bolt 81 that secures the link 79 to the plate 19 in various adjusted positions.

As best shown in Figs. 6 and 7, a trip lever 82 is connected to the lower end of the arm 77 by a horizontal pivot pin 83 and is provided with a short rearwardly projecting arm 84 to which an elongated actuating bar 85 is connected by a pivot pin 86. As best shown in Fig. 8, the actuating bar 85 has an elongated slot 87 in its upper end that receives the pivot pin 78 which serves to guide the vertical movement of the bar 85. The bar 85 has a flange 88 at its upper end that carries a vertical screw 89 that engages with an enlarged portion 90 of the pivot pin 78 to effect vertical adjustments of the bar 85 and a clutch actuating detent 91 that is carried by the bar. The actuating detent 91 is connected at its lower end to the bar by a pivot 92 and has a pin 93 engageable with the bar 85 to limit the swinging movement of the detent 91 toward the shaft 60, the detent 91 being held in a position in which the stop pin 93 engages the bar 85 by means of a spring 94 that is coiled around the pivot 92 and that has one end engaging the pin 93 and the other end engaging a pin 95 carried by the bar 85 below the pivot 92. The detent 91 has a triangularly shaped upper end portion providing an end face 96 that is substantially horizontal and that normally underlies the shaft 74 carried by the pawl actuating arm 73. Below its upper end face 96 the detent 91 has a laterally inclined cam face 97 with which the shaft 74 engages during the final portion of the revolution of the shaft 60 to brush the detent out of the path of the shaft and to press the roller 75 against the periphery of the disk 70, so as to assist movement of the roller 75 into the notch 76 when the roller comes into registry with the notch. After the shaft 74 has passed the upper end of the member 91, the spring 94 swings the detent 91 toward the shaft 60 until the pin 93 engages with the bar 85, in which position the

6

end face 96 of the detent underlies the shaft 74, resetting the clutch mechanisms for actuation by the next article to engage the trip lever 82. Engagement of an article with the trip lever 82 rocks the lever forwardly, lifting the actuating bar 85 and engaging the upper end 96 of the member 91 with the shaft 74 to lift the roller 85 out of engagement with the recess 76 and to engage the pawl 62 with the ratchet 59, after which the shaft 60 makes a complete revolution, returning the roller 75 to the notch 76 and disengaging the pawl 62.

For convenience in threading a label strip and in making adjustments, it is desirable that the actuator shaft be manually operable. To this end a handle 98 is provided on the outer end of the shaft 60 as shown in Figs. 1 and 10, and a handle 99 is provided on the locking pin 72 so that the disk 70 may be conveniently released to permit its rotation with the shaft 60. During manual rotation of the shaft 60 the roller 75 engages in the recess 76 and the disk 70 turns with the shaft 60, the pawl 62 being held out of engagement with the ratchet 59 by the spring 62a so that the actuator shaft 60 may be readily turned by means of the handle 98.

As best shown in Fig. 6, a shaft 100 is mounted in the extension 23 inwardly of the feed drum 25 and this shaft is driven from the actuator shaft 60 at the same speed as the shaft 60 by a sprocket chain 101. The shaft 24 of the feed drum 25 has a ratchet wheel 102 attached thereto provided with teeth 103 that have the same angular spacing as the label strip engaging teeth 26 on the drum 25. A pawl arm 104 is pivotally mounted on the shaft 24 and carries a pawl 105 that is pressed by a spring 106 into engagement with the ratchet 102. The drum 25 is intermittently actuated by the shaft 100 which is connected to the pawl arm 104 through a crank 107 attached to the shaft 100 and a connecting rod 108 pivoted to the crank 107 and to the pawl arm 104.

When the shaft 60 is disengaged from the shaft 67 the crank 107 is positioned between the shafts 100 and 24 as shown in Fig. 6 of the drawings, so that the label feed drum 25 remains stationary after the roller 75 is disengaged from the notch 76 and until the return movement of the pawl arm 104 toward the shaft 100 is completed. Upon reversal of movement of the pawl arm 104 the pawl 62 is engaged with the ratchet 59 and the crank 107 is actuated to impart a turning movement to the ratchet 102 and shaft 24. During the second half of the revolution of the shaft 100 the label feed drum 25 and the feed rollers 34 and 35 are actuated to advance the label strip one label length to bring the leading label of the strip to a position to be severed and applied to the next article brought into engagement with the trip lever 82.

A sprocket chain 110 driven by the shaft 24 passes over guide sprockets 111 and 112, over a sprocket 113 that drives the feed roller 34, over a sprocket 114 on a shaft 115 that operates a part of the printing mechanism, as will be later explained, and over an idler guide sprocket 116. Suitable means is provided for tightening the chains 101 and 110 such as adjustable tightening sprockets 117 and 118.

As shown in Figs. 3 and 13, a cam 119 on the shaft 60 engages a roller 120 on a lever arm 121 fixed to a horizontal shaft 21 carried by the plate 19 and a lever arm 123 fixed to the shaft 122 engages a roller 124 on the upper end of the slide 38 to move the slide 38 in opposition to the spring 54 to sever a label from the leading end of the label strip. The raised portion 119a of the cam 119 is positioned to actuate the cutter blade 37 immediately after the pawl 62 is engaged with the ratchet 59 by actuation of the trip lever 82 to sever a label from the leading end of the label strip which is positioned directly over an article engaging the trip lever 85.

As shown in Figs. 3 and 4, a second cam 125 on the shaft 60 engages a roller 126 carried by an arm 127 pivoted to the shaft 115, the arm 127 being held in engagement with the cam 125 by a spring 128. The arm 127

extends upwardly from the shaft 115 and supports a rotating printing member 129 at its upper end alongside the guide bar 29. The rotating member 129 has diametrically opposite type blocks 130 which alternately engage with an inking pad 131 and with the portion of the label strip that engages a flat backing face 132 on the guide block 29. A sprocket chain 133 provides a driving connection between the printing member 129 and the shaft 115. The shaft 115 is geared to the drum 25 and turns while the drum 25 is being turned, the driving ratio being such that a one-half revolution is imparted to the printing member 129 upon each actuation of the feed drum 25. The cam 125 is so formed that it permits the arm 127 to be held by the spring 128 in a position where one of the type blocks 130 engages with the inking pad 131 when the actuator shaft 60 is stopped.

When the rotation of the shaft 60 is started by engagement of the pawl 62 with the ratchet 59, the cam 125 swings the arm 127 to move the printing member 129 from a position where one of the type blocks 130 engages the inking pad 131 to a position where the other of the type blocks 130 engages the label on the flat backing face 132 of the guide block 29. The printing operation is performed by movement of the arm 127 rearwardly to the position shown in Fig. 4 before the label strip feed mechanism is operated. The arm 127 is swung forwardly by the spring 128 during the feed movement of the tape strip and during the turning movement of the tape strip feed drum 25 the member 129 is turned through an angle of 180° by the sprocket chain 133 to reverse the position of the printing member 129 and to bring the type block 130 that had engaged the tape strip into engagement with the inking pad 131.

As shown in Figs. 3 and 5, a third cam 134 on the shaft 60 engages a roller 135 on a lever arm 136 that is attached to a shaft 137 carried by the plate 19 to which is attached a downwardly extending arm 138 that is connected to a label presser head 139 by a link 140. The head 139 is connected by a pivot 141 to a supporting bracket 142 that has inner and outer arms 143 and 144 that straddle the head 139 and that is attached to the plate 19 by bolts 145. The head 139 extends rearwardly from the pivot 141 and the link 140 is attached to the head 139 rearwardly of the pivot 141 so that the head 139 is moved about its pivot 141 by the lever arm 138. The head 139 has a series of metal ironing members 146 mounted therein, all of which extend longitudinally of the conveyor and each of which has an elongated flat label engaging bottom face 147 as shown in Fig. 10. The members 146 have heat conducting webs 148 that are slidably mounted in the head 139 and which are yieldably supported on the pivot 141 and on a cross rod 149 parallel to the pivot 141, the webs 148 of the members 146 being provided with upwardly extending parallel elongated slots 150 which receive the pins 141 and 149. The ironing members 146 are normally suspended from the pivot 141 and cross rod 149 with the upper ends of the slots 150 engaging the pivot 141 and cross rod 149 and the lever 138 is so positioned when the actuator shaft 60 is in its stationary position that the article engaging faces 147 of the ironing members 146 are supported in an inclined position and in the path of the top portions of articles being advanced by the conveyor.

The ironing members 146 are positioned forwardly of but adjacent to the cutter blade 37 and are normally positioned with their rear ends above the strip guiding blade 43 so that the leading end of the label strip is supported in an inclined position directly beneath the forward ends of the ironing members 146 where it will engage with the top face of the article to be labeled when the article engages the trip lever 182 prior to the actuation of the label severing blade 37. The cam 134 is so formed that the lever arm 138 is actuated to depress the forward end of the ironing members 146 substantially simultaneously with the actuation of the label severing knife 37. When

the ironing members 146 are lowered into engagement with a label on the article their weight is imposed upon the article and they are free to move upwardly in the head 139 during the passage of the article beneath the members 146. The head 139 is provided with a suitable electric heater 151 which transmits sufficient heat through the webs 148 to the ironing members 146 to fuse a thermoplastic coating on the label and cause it to adhere to the article.

In order to hold the label strip taut between the reel 22 and the label feed drum 25, means is provided to frictionally retard the rotation of the reel 22. As shown in Fig. 2, the reel 22 is mounted on a sleeve 152 that is rotatably mounted on the shaft 21, the reel 22 being detachably secured to the sleeve 152 by means of a taper pin 153 held in locking position by a nut 154. The sleeve 152 is mounted between a collar 155 fixed to the shaft 21 and a cap 156 adjustably connected to the free end of the shaft 21 by means of a screw 157. Brake washers 158 of leather or other suitable friction material are interposed between the ends of the sleeve 152 and the collar 155 and cap 156. By adjusting the screw 157 the pressure on the brake washers 158 can be regulated to provide the desired retarding effect.

The label feeding and guiding rolls are detachably mounted on the supporting plate 19 and are replaceable with other longer or shorter rollers to accommodate label strips of various widths and the shaft 21 is adjustably mounted in the supporting plate to enable the reel to be centered with respect to the strip feed and guide rollers, the shaft 21 being held in adjusted positions by suitable means such as a set screw 159.

The labeling mechanism of the present invention is designed particularly for applying labels to wrapped articles as they are delivered from a wrapping machine. Wrapping machines such as those designed for the wrapping of bakery products are capable of wrapping articles which vary greatly in size and shape and the speed at which the wrapped articles are wrapped and conveyed from the wrapping machine may vary considerably. The labeling mechanism of the present invention can be quickly and easily adjusted for articles of different heights by adjusting the slide 6 and for articles of different lengths by adjustment of the slide 14. The proper timing of the label applying mechanism with respect to the rate of conveyor movement can readily be obtained independently of the speed of the conveyor by adjustment of the article engaging trip 83 longitudinally of the conveyor to determine the position occupied by the article at the instant when the label is severed from the strip and pressed against the article by the ironing shoes 146.

In the operation of the machine an article being advanced by the conveyor 3 engages with the trip lever 82 positioned alongside the ironing members 146 and pushes the lever forwardly to rock the same about the pivot 83 and impart a vertical movement to the actuating bar 85. The top face 96 of the detent 91 moves upwardly into engagement with the shaft 74 on the pawl arm 73, lifting the pawl arm 73 and rocking the pawl 62 into engagement with a tooth of the ratchet 59, starting the rotation of the actuator shaft 60. The movement of the pawl 62 with the ratchet 59 pulls the roller 75 into engagement with the circular periphery of the control disk 70, holding the pawl 62 in engagement with the ratchet 59 during a complete revolution of the shaft 60, the roller 75 being returned to its dwell position in engagement with the notch 76 in the stationary disk 70 where it is held by the pawl releasing spring 62a.

When the shaft 60 starts to turn, the high point 119a of the cam 119 actuates the lever 123 to sever a label from the leading end of the label strip and the cam 134 simultaneously lowers the label ironing members 146 into engagement with the label to press it against the top of the article and apply heat thereto to fuse its thermoplastic coating while the bottom faces 147 of the ironing members slide over the label. While each severed label is

being applied to an article any desired indicia may be printed on another label in the label strip that overlies the backing face 132 of the guide bar 29 during the label applying operation, the arm 127 being actuated by the cam 125 immediately after the shaft 60 begins its rotation to swing the printing member 129 to its label engaging position shown in Fig. 4.

During the last half of the revolution of the shaft 60 the feed drum 25 and feed rollers 34 and 35 are turned by means of the pawl 165 and ratchet 102 to advance the strip one label length, the peripheral speed of the rollers 34 and 35 being slightly greater than the peripheral speed of the feed drum 25 to maintain tension on the strip. Since there is some slippage between the label strip and the rollers 34 and 35, excessive frictional resistance to such slippage is undesirable and the roller 34 may have its label strip engaging periphery formed of spaced ribs 34a to reduce the area of contact between its periphery and the label strip. During the feed movement of the label strip the arm 127 is swung away from the label strip and toward the inking pad 131 and the printing member is turned through an angle of 180° to reverse the positions of the type blocks 130, so that the type blocks engage alternately with the ink pad and label strip.

When the revolution of the shaft 60 is completed the roller 75 is brought into alinement with the notch 76 and is forced into the notch 76 by the pawl releasing spring 62a. In this position of the shaft 60 the raised portion of the cam 119 engages the roller 120 on the arm 121 of the cutter actuating lever which offers sufficient resistance to further rotation of the shaft 60 to prevent overrunning.

In threading a label strip from a fresh roll, the strip is unwound from the roll sufficiently to pass it under the guide roller 28 and over the feed drum 25, after which the locking pin 72 is moved out of engagement with the control disk 70 allowing the disk 70 and shaft 60 to turn freely and the shaft 60 is then rotated manually while the leading end of the label strip is threaded over the guide bar 29 and rollers 30, 31 and 34.

The manual operation can continue to cause labels to be severed from the strip to determine the proper adjustment of the strip with respect to the cutter blade 37. To obtain the desired registration of the label strip notches B with the blade 37, the guide roller 30 may be adjusted in the slot 32 to advance or retard the leading end of the label strip to bring the notches into registry with the cutter blade 37. After the strip has been threaded and properly registered with the cutoff blade 37, the locking pin 72 will be engaged with the opening 71 in the disk 70 and the labeling mechanism is ready for automatic operation to apply labels to articles advanced beneath it by the conveyor 3.

It is to be understood that in accordance with the provisions of the patent statutes, variations and modifications of the specific devices herein shown and described may be made without departing from the spirit of the invention.

What we claim is:

1. A labeling machine comprising a conveyor for advancing articles one at a time, a labeling mechanism having label applying means engageable with articles as they are moved by said conveyor past said labeling mechanism, means for feeding labels to said label applying means and a motor for driving said label feeding means and label applying means independently of said conveyor, a shaft driven by said motor, a clutch for connecting said labeling mechanism to said shaft, a trip in the path of articles moving past said label applying means, means operated by said trip for engaging the clutch to drive the labeling mechanism, means for automatically disengaging said clutch after delivery of a label to said applying means, and means for adjusting said trip longitudinally of said conveyor to advance or

retard the operation of said labeling mechanism with respect to the movement of said conveyor.

2. A labeling machine comprising a conveyor for advancing articles one at a time, a labeling mechanism having label applying means engageable with articles as they are moved by said conveyor past said labeling mechanism, means for feeding labels to said label applying means and a motor for driving said labeling mechanism independently of said conveyor, a shaft driven by said motor, a clutch for connecting said labeling mechanism to said shaft, a supporting member pivoted to swing about a pivot adjacent said clutch and disposed transversely of the conveyor, said member having a free end adjacent said conveyor, a trip member pivoted to the free end of said supporting member and positioned in the path of articles moving past said label applying means, means for securing said supporting member in different positions of angular adjustment to vary the distance between said trip member and said label applying means, means operated by said trip member for engaging said clutch to operate said labeling mechanism and means for automatically disengaging said clutch after completion of the labeling operation.

3. A labeling machine comprising a conveyor for advancing articles one at a time, a labeling mechanism having label applying means engageable with articles on said conveyor and means for delivering labels one at a time to said applying means, a motor for driving said mechanism independently of said conveyor, a rotatable driving member and means actuated by said member during each revolution thereof for operating said label delivering means and said label applying means, a clutch mechanism having means for establishing a driving connection between said motor and said driving member and for automatically disconnecting said driving member from said motor upon completion of a revolution of said driving member, a movable trip member positioned in the path of articles on said conveyor, means for adjusting said trip member longitudinally of the conveyor to advance or retard the operation of the labeling mechanism with respect to said conveyor, and means connecting said trip member to said clutch mechanism and operable to connect said driving member to said motor when said trip member is moved by an article in the various positions of adjustment of said trip member.

4. A labeling machine comprising a conveyor for advancing articles one at a time, a labeling mechanism having label applying means engageable with articles on said conveyor and means for delivering labels one at a time to said applying means, a motor for driving said mechanism independently of said conveyor, a rotatable driving member and means actuated by said member during each revolution thereof for operating said label delivering means and said label applying means, a clutch mechanism having means for establishing a driving connection between said motor and said driving member and for automatically disconnecting said driving member from said motor upon completion of a revolution of said driving member, a supporting member pivoted to swing about an axis transverse to said conveyor, a trip member pivoted to the free end of said supporting member and extending into the path of articles on said conveyor as they approach said label applying means, means for securing said supporting member in different positions of adjustment to vary the distance between said trip member and said label applying means, and an operating connection between said trip member and said clutch mechanism.

5. A top labeler comprising means for supporting a label strip roll, label applying means, a bed beneath said label applying means along which articles may be advanced past said label applying means, means for feeding said strip from said roll to said label applying means, means adjacent said label applying means for severing labels from said strip, a shaft, means for continuously

driving said shaft, a second shaft connected to said feeding means, severing means and label applying means to operate the same to advance the label strip one label length, sever a label from the strip and actuate said label applying means during a predetermined turning movement of said shaft, a clutch movable to an engaging position to connect said second shaft to said continuously driven shaft, means for automatically releasing said second shaft after it has completed said predetermined turning movement, a trip in the path of articles approaching said applying means, and means operated by said trip for shifting said clutch to engaging position.

6. A top labeler comprising a bed along which articles to be labeled may be advanced, a heated label ironing member, means supporting said member in a position above said bed with its bottom label engaging face facing approaching articles at an inclination to the bed with the lower end thereof in the path of articles on said bed and the upper end thereof above the tops of the articles, a trip member in the path of articles passing beneath said member, and means controlled by said trip for delivering a label onto the top of an article beneath the inclined bottom face of said ironing member and for swinging said ironing member from said position to a substantially horizontal position to transfer the weight of said ironing member from said supporting means to said article so as to press the label against the top of the article.

7. A top labeler comprising a bed along which articles to be labeled may be advanced, a series of separate heated label ironing members, means supporting said members side by side for independent vertical movements with their bottom faces facing approaching articles at an inclination to the path of travel of said articles with their lower ends in the path of the tops of articles on said bed and their upper ends above the tops of the articles, and means for automatically feeding a label toward said ironing members into the space between the top of the article and the ironing members and for depositing the same on the top of an article approaching said ironing members and for automatically lowering said members into engagement with the label.

8. A top labeler comprising a bed along which articles to be labeled may be advanced, a series of separate heated label ironing members, means supporting said members side by side for independent vertical movements with their bottom faces facing approaching articles at an inclination to the path of travel of the articles with their lower ends in the path of the tops of articles on said bed and their upper ends above the tops of the articles, a trip member in the path of articles passing beneath said ironing members, means controlled by said trip for delivering a label onto the top of an article approaching said ironing members beneath said ironing members and for lowering said members into engagement with the label, and means for adjusting said trip toward and away from said label feeding means to vary the position of the label on said article.

9. A top labeler comprising a conveyor for moving articles one at a time along a linear path, a labeling mechanism overlying said path and having a label presser comprising a series of ironing members disposed side by side and having elongated label engaging bottom faces extending longitudinally of said path and a supporting head for said ironing members mounted to swing about a horizontal axis transverse to said path, said ironing members each having parallel elongated slots perpendicular to its bottom face and said head having horizontal rods extending through said slots to support said ironing members, means for normally supporting said head in a position to support said ironing members with their bottom faces facing approaching articles at an inclination to the path of travel of said articles with their lower ends in the path of approaching articles and their upper ends above the top of said articles, a trip in the path of articles approaching said presser, means controlled by said trip for deliver-

ing a label onto the top of an article engaging the trip and beneath said ironing members, and means also controlled by said trip for swinging said holder about its pivotal axis to move said ironing faces toward horizontal position and into pressing engagement with the label.

10. In a labeling machine having a conveyor for articles to be labeled and a labeling mechanism having label strip feeding means, label severing means and label applying means, the combination therewith of an actuating mechanism comprising an actuator shaft, means operably connecting said shaft to said feeding means, said severing means and said applying means for operating the same sequentially during each revolution of said shaft, a continuously rotating drive shaft axially aligned with said actuator shaft, a ratcheted fixed to said drive shaft, a pawl mounted on said actuator shaft and movable radially into and out of engagement with said ratchet, said pawl being biased toward disengaged position and having a laterally projecting arm, a pawl controlling disk rotatably mounted on one of said shafts and having its periphery in engagement with said arm, said periphery having a circular portion for holding said pawl in ratched engaging position and an arm receiving recess that permits movement of the pawl to disengaged position, a locking means for holding said disk against rotation, said locking means being releasable to permit rotation of said actuator shaft independently of said drive shaft, a movable trip member in the path of articles moved by said conveyor, and means operated by said trip for shifting said pawl arm out of engagement with said recess to initiate a revolution of said actuator shaft.

11. In a labeling machine having a conveyor for articles to be labeled and a labeling mechanism having label feeding means, label severing means and label applying means, the combination therewith of an actuating mechanism comprising an actuator shaft, means operably connecting said shaft to said feeding means, said severing means and said applying means for operating the same sequentially during each revolution of said shaft, a continuously rotating drive shaft axially aligned with said actuator shaft, a ratcheted fixed to said drive shaft, a pawl mounted on said actuator shaft and movable radially into and out of engagement with said ratchet, said pawl being biased toward disengaged position and having a laterally projecting arm, a pawl controlling disk rotatably mounted on one of said shafts and having its periphery in engagement with said arm, said periphery having a circular portion for holding said pawl in ratchet engaging position and an arm receiving recess that permits movement of the pawl to disengaged position, means for holding said disk against rotation with said recess above the disk axis, a trip support pivotally suspended to swing about a horizontal pivot that is positioned adjacent said recess, a trip lever pivoted to the lower end of said support and having an arm in the path of articles moved by said conveyor, an actuating bar connected to said lever and slidably connected to said pivot, a pawl actuating detent carried by said bar for freeing said pawl from said recess and engaging the same with said ratchet, and means for securing said trip support in different positions of angular adjustment to adjust said trip lever longitudinally of said conveyor independently of the label applying means.

12. A labeling machine comprising label severing and applying means, means for feeding a label strip to said severing and applying means comprising a feed drum having spaced strip engaging projections, feed rollers engaging the strip adjacent said severing and applying means, spaced guides over which the label strip passes between said drum and said feed rollers, one of said guides being adjustable transversely of the label strip to advance or retard the strip with respect to said severing means and one of said guides being stationary and having a flat face over which the label strip passes, means operating intermittently with a dwell after each operation for turning said drum and said feed rollers to advance the strip one label length, and

13

means operating during each dwell between label feeding operations for actuating said severing and applying means and for printing upon the portion of the label strip engaging the flat portion of said guide.

References Cited in the file of this patent**UNITED STATES PATENTS**

1,226,268 Smith ----- May 15, 1917

1,424,165
2,029,394
2,192,132
2,248,744
2,286,159
2,326,436
2,329,669
2,540,694

5

14

Howe ----- Aug. 1, 1922
Sidebotham ----- Feb. 4, 1936
Gautier ----- Feb. 27, 1940
Cohen ----- July 8, 1941
Reynolds ----- June 9, 1942
Caldwell ----- Aug. 10, 1943
Tuthill ----- Sept. 14, 1943
Sieg ----- Feb. 6, 1951