

(19)



(11)

**EP 4 140 467 A1**

(12)

**EUROPEAN PATENT APPLICATION**

(43) Date of publication:  
**01.03.2023 Bulletin 2023/09**

(51) International Patent Classification (IPC):  
**A61J 1/16** <sup>(2006.01)</sup>      **A61J 1/20** <sup>(2006.01)</sup>  
**B65D 35/28** <sup>(2006.01)</sup>      **B65D 35/32** <sup>(2006.01)</sup>

(21) Application number: **21192975.7**

(52) Cooperative Patent Classification (CPC):  
**A61J 1/16**; **A61J 1/2093**; **B65D 81/3266**

(22) Date of filing: **25.08.2021**

(84) Designated Contracting States:  
**AL AT BE BG CH CY CZ DE DK EE ES FI FR GB GR HR HU IE IS IT LI LT LU LV MC MK MT NL NO PL PT RO RS SE SI SK SM TR**  
Designated Extension States:  
**BA ME**  
Designated Validation States:  
**KH MA MD TN**

- **Körber, Guido**  
**37287 Wehretal (DE)**
- **Loewensberg, Denis**  
**1071 Chexbres (CH)**
- **Schütrumpf, Jens**  
**36251 Bad Hersfeld (DE)**
- **Völker, Tobias**  
**34621 Frielendorf/Verna (DE)**

(71) Applicant: **B. Braun Melsungen AG**  
**34212 Melsungen (DE)**

(74) Representative: **Patentanwälte**  
**Ruff, Wilhelm, Beier, Dauster & Partner mbB**  
**Kronenstraße 30**  
**70174 Stuttgart (DE)**

(72) Inventors:  
• **Chervin, Christophe**  
**74160 Neydens (FR)**

(54) **PEEL SEAM OPENING AID AND METHOD FOR OPENING PEEL SEAMS OF A MULTICHAMBER BAG**

(57) The invention relates to a peel seam opening aid (1) for opening peel seams (46) of a multichamber bag (4) having a first end (41) with a port system (40) and an opposite second end (42) with a bottom edge (43), the peel seam opening aid (1) comprising two gripping elements (2) and an elongated central part (3) arranged between the two gripping elements (2), wherein the central part (3) is provided with an gap (32) extending in an axial direction of the central part (3) configured to

allow the bottom edge (43) or a corner region of the bottom edge (43) to be inserted through the gap (32) from a first side to protrude at an opposite second side to enable rolling the multichamber bag (4) onto the central part (3).and method for opening peel seams of a multichamber bag. The invention relates to a method for opening peel seams (46) of a multichamber bag (4) using such a peel seam opening aid (1).

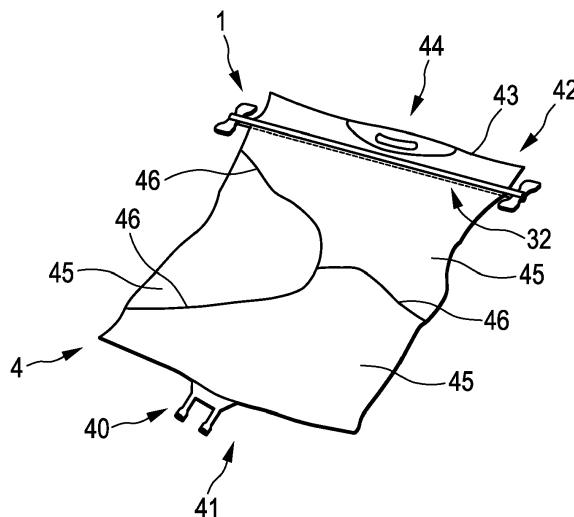

**FIG. 2**

**EP 4 140 467 A1**

## Description

### TECHNICAL FIELD AND PRIOR ART

**[0001]** The invention relates to a peel seam opening aid and method for opening peel seams of a multichamber bag.

**[0002]** In the context of the application, multichamber bags, for example multichamber nutrition bags, are film bags, which are subdivided in smaller individual chambers separated by peel seams. In embodiments of the multichamber bag, the multichamber bag has two or three individual chambers. In other embodiments, the multichamber bag has four, five or even more than five individual chambers. The peel seams separating the individual chambers have a lower sealing strength than contour seams of the multichamber bags. By applying pressure to the individual chambers, the pressure in the individual chambers is increased until the peel seams break or open, allowing the content of the chambers to mix. In case the bag has more than two individual chambers, typically a pressure is applied so that the peel seams are opened one after the other. The multichamber bags have a first end with a port system and an opposite second end with an edge referred to as bottom edge. The expression bottom edge is only used to distinguish the edge from other edges. In use, the bottom edge typically is arranged at a top.

**[0003]** One known procedure to open the peel seams, is to roll-up the multichamber bag starting from the bottom edge opposite to the port-system of the bag. By rolling up the bottom edge of the bag, an internal pressure is built-up inside a chamber closest to the bottom edge up to a level that causes a peel seam separating this chamber from another chamber to open.

**[0004]** US 2017/101253 A1 shows a peel seam opening aid with an elongated central part having two distal gripping elements. The central part has a means for fixation of a partial area of a multichamber bag, which in the most preferred embodiment of US 2017/101253 A1 comprises a moveable clamping element.

### SUMMARY OF THE INVENTION

**[0005]** It is the object of the invention to provide a peel seam opening aid, which does not require any moveable fixation or clamping elements and is easy to use and to manufacture. It is a further object of the invention to provide a method for opening peel seams using a peel seam opening aid.

**[0006]** These objects are solved by the peel seam opening aid and the method with the features of claims 1 and 11. Preferred embodiments are defined in the dependent claims.

**[0007]** According to a first aspect, a peel seam opening aid for opening peel seams of a multichamber bag having a first end with a port system and an opposite second end with a bottom edge is provided, wherein the peel

seam opening aid comprises two gripping elements and an elongated central part arranged between the two gripping elements, wherein the central part is provided with a gap extending in an axial direction of the central part configured to allow the bottom edge or a corner region of the bottom edge to be inserted through the gap from a first side to protrude at an opposite second side to enable rolling the multichamber bag onto the central part.

**[0008]** Throughout this description and the claims, the indefinite article "a" or "an" means "one or more". Reference to "a first element" does not mandate presence of "a second element". Further, the expressions "first" and "second" are only used to distinguish one element from another element and not to indicate any order of the elements.

**[0009]** In the context of the application, a gap is defined as an opening between two distinct elements forming the central part or as a passage opening in the central part or in an element of a multielement central part. A gap in the form of an opening in the central part or in an element of a multielement element central part is also referred to as slot.

**[0010]** Providing a gap configured to allow the bottom edge or a corner region of the bottom edge to be inserted through the gap from a first side so as to protrude at an opposite second side allows a film-to-film contact between the second end of the multichamber bag and a region of the multichamber bag contacted by the second end upon starting to rotate the central part in order to roll the multichamber bag onto the central part. Due to the high level of friction of the film-to-film contact, a clamping element or any other fixation element provided in prior art devices can be omitted. Hence, a device which is easy in handling and in manufacturing is provided.

**[0011]** In use, in one embodiment, the peel seam opening aid is positioned and rotated parallel to the bottom edge. In other embodiments, the peel seam opening aid is positioned with an angle to the bottom edge, in particular an angle up to 45°, wherein a corner region of the bottom edge is inserted through the gap and the peel seam opening aid is rotated with an angle to the bottom edge.

**[0012]** In order to allow the bottom edge or a corner region of the bottom edge to be inserted through the gap and to allow a subsequent retention of the bottom edge or a corner region of the bottom edge, in embodiments of the invention a size of the gap is chosen so that the size of the gap is close to a thickness of the multichamber bag. In embodiments, the size of the gap is between 2 mm and 6 mm, in particular between 2 mm and 4 mm.

**[0013]** In embodiments of the peel seam opening aid, the central part comprises two rods arranged with the gap between them. The rods in embodiments are metal rods, in other embodiments, the rods are made of synthetic material. Other materials, such as wood, are also conceivable. However, materials allowing for a good washability and disinfectibility are preferred in particular in a pharmaceutical and hospital sector.

**[0014]** In embodiments, the central part comprises two rods of the same design. In other embodiments, the central part comprises two rods that differ in design. Rods of any arbitrary cross-section are conceivable to the person skilled in the art, wherein cross-sections, which at least at a region of the gap have a smooth surface avoiding sharp edges that may damage the multichamber bag are advantageous.

**[0015]** In embodiments of the central part, the rods have a circular or semi-circular cross-section or are in the form of profile rods. Such rods are available as low-cost mass products, allowing for a cost-efficient production of the peel seam opening aid of high quality.

**[0016]** In an embodiment of the peel seam opening aid, the gripping elements are mounted between the two rods. In this case, the gripping elements also function as spacers for forming the gap between the two rods.

**[0017]** In another embodiment of the peel seam opening aid, the gripping elements are mounted to end faces of the two rods. The rods in one embodiment are directly mounted to the gripping elements. In other embodiments, the rods are attached to each other and to the gripping elements using a mounting bracket.

**[0018]** The gripping elements and the rods can be fixed to each other using any suitable fixation method, including welding, gluing, screwing, riveting, pressing and others.

**[0019]** In other embodiments of the peel seam opening aid, the central part is a one-piece element provided with the gap in the form of an elongated slot. The slot in one embodiment is formed by milling. For a cost-efficient and simple manufacturing, in other embodiments the central part is an injection moulded one-piece element.

**[0020]** At opposite ends of the central part, two gripping elements are provided, which are designed to allow gripping the peel seam opening aid and rotating it about its longitudinal axis.

**[0021]** In one embodiment, the peel seam opening aid is a one-piece element comprising the central part and the gripping elements. In other words, the gripping elements are formed integrally with the central part.

**[0022]** In embodiments, the gripping elements - regardless of whether they are formed integrally with the central part or separately - are selected from a group comprising a two-wing knob, a multi-wing knob, a ball-shaped knob, a triangular knob, a star-shaped knob, a cylindrical knob, a knurled knob, and a cross-rod. The gripping elements in one embodiment are metal gripping elements. In other embodiments, gripping elements made of synthetic material are used.

**[0023]** According to a second aspect, a method for opening peel seams of a multichamber bag having a first end with a port system and an opposite second end with a bottom edge using a peel seam opening aid is provided, wherein the bottom edge of the multichamber bag or a corner region of the bottom edge is inserted through the gap from a first side to protrude at an opposite second side and the multichamber bag is rolled onto the central

part until a pressure in the multichamber bag exceeds a sealing strength of the peel seams and breaks them open.

**[0024]** By inserting the bottom edge or a corner region of the bottom edge through the gap from a first side so that it protrudes at an opposite second side and a subsequent rotating of the central part over at least 180° a film-to-film contact between the second end of the multichamber bag and a region of the multichamber bag contacted by the second end is established. Due to the high level of friction of the film-to-film contact, a subsequent rolling of the multichamber nutrition bag onto the peel seam opening aid without slippage is possible.

**[0025]** In one embodiment, the peel seam opening aid is positioned and rotated parallel to the bottom edge. In other embodiments, the peel seam opening aid is positioned with an angle to the bottom edge, in particular an angle up to 45°, wherein a corner region of the bottom edge to be inserted through the gap.

**[0026]** In an embodiment, the bottom edge or corner region is inserted to protrude at the second side over a distance which is equal to or larger than the diameter of the central part. This ensures for a sufficient film-to-film contact when rotating the peel seam opening aid.

**[0027]** The diameter of the central part is defined as a diameter of an enveloping circular cylinder around the central part.

#### BRIEF DESCRIPTION OF THE DRAWINGS

**[0028]** In the following, embodiments of the invention will be described in detail with reference to the drawings. Throughout the drawings, the same elements will be denoted by the same reference numerals.

Fig. 1 shows a first embodiment of a peel seam opening aid.

Fig. 2 shows a first stage in use of the peel seam opening aid of Fig. 1 for opening a multichamber bag.

Fig. 3 shows a second stage in use of the peel seam opening aid of Fig. 1 for opening a multichamber bag.

Fig. 4 shows a third stage in use of the peel seam opening aid of Fig. 1 for opening a multichamber bag.

Fig. 5 shows a second embodiment of a peel seam opening aid.

Fig. 6 shows a third embodiment of a peel seam opening aid.

Fig. 7 shows a fourth embodiment of a peel seam opening aid.

Fig. 8 shows an end with a gripping element of a fifth embodiment of a peel seam opening aid.

Fig. 9 shows an end with a gripping element of a sixth embodiment of a peel seam opening aid.

Fig. 10 shows an end with a gripping element of a seventh embodiment of a peel seam opening aid and

Fig. 11 shows an end with a gripping element of an eighth embodiment of a peel seam opening aid.

#### DETAILED DESCRIPTION OF EMBODIMENTS OF THE INVENTION

**[0029]** Fig. 1 shows in a perspective view a peel seam opening aid 1 for opening peel seams of a multichamber bag (not shown in Fig. 1).

**[0030]** The peel seam opening aid 1 comprises two gripping elements 2 and an elongated central part 3 arranged between the two gripping elements 2.

**[0031]** In the embodiment shown in Fig. 1, the central part 3 comprises two rods 30 having a semi-circular cross-section, which are arranged in parallel so that flat sides of the two rods 30 face each other. The rods 30 are arranged with a gap 32 between them, which gap 32 extends in an axial direction of the central part 3. The gap 32 is configured to allow a passage of a the bottom edge or a corner region of the bottom edge of a multichamber bag 4 (see Fig. 2) between the two rods 30. In embodiments of the invention, a size of the gap 32 is chosen so that the size of the gap 32 is close to a thickness of the multichamber bag 4, for example the size of the gap is between 2 mm and 6 mm, in particular 5 mm or between 2 mm and 4 mm.

**[0032]** In the embodiment shown, the gripping elements 2 are mounted between the two rods 30, wherein the gripping elements 2 also function as spacers for forming the gap 32. The gripping elements 2 and the rods 30 can be fixed to each other using any suitable fixation method, including welding, gluing, screwing, riveting, pressing and others.

**[0033]** The two gripping elements 2 are designed to allow gripping the peel seam opening aid 1 and rotating it about its longitudinal axis. In the embodiment shown in Fig. 1, the gripping elements 2 are in the form of wing knobs having two flat wings 20 offset by 180°, which extend perpendicular to an axial direction of the central part 3.

**[0034]** Figs. 2 to 4 show different stages in use of the peel seam opening aid 1 of Fig. 1 for opening a multichamber bag 4. The multichamber bag 4 has a first end 41 with a port system 40 and an opposite second end 42 with a bottom edge 43. In the embodiment shown, a hanger in the form of an opening 44 is provided at the second end 42.

**[0035]** The multichamber bag 4 shown in Figs. 2 to 4 has three individual chambers 45, which are separated by peel seams 46. In other embodiments, the multichamber bag has only two individual chambers 45 or more than three individual chambers 45, for example four or five individual chambers 45, which are separated by peel seams 46.

**[0036]** As shown in Fig. 2, for opening the peel seams 46 of the multichamber bag 4 using the peel seam opening device 1, the bottom edge 43 of the multichamber bag 4 is inserted through the gap 32 from a first side to protrude at an opposite second side.

**[0037]** Next, as shown in Fig. 3, the peel seam opening aid 1 is rotated about 180° so that the second end 42 of the multichamber bag 4 is flipped over towards the first end 41 contacts another region of the multichamber bag 4. This film-to-film contact ensures a high level of friction and allows for a subsequent rolling of the multichamber bag 4 onto the central part 4.

**[0038]** As schematically shown in Fig.4, by rotating the peel seam opening aid 1 the multichamber bag 4 is rolled onto the central part 3 until a pressure in an individual chamber 45 or in two or more already combined individual chambers 45 exceeds a sealing strength of the peel seams 46 and breaks them open.

**[0039]** To allow for a sufficient friction, in embodiments the bottom edge 43 is inserted to protrude at the second side over a distance which is equal to or larger than the diameter of the central part 3.

**[0040]** In the embodiment of a use of the peel seam opening aid 1 shown in Figs. 2 to 4, the peel seam opening aid 1 is positioned in parallel to the bottom edge 43, the bottom edge 43 is inserted over its entire length, and the peel seam opening aid 1 is rotated parallel to the bottom edge. Depending on the design of the multichamber bag and/or the peel seam opening aid 1, in other embodiments, the peel seam opening aid 1 is positioned with an angle to the bottom edge, in particular an angle up to 45°, wherein only a corner region of the bottom edge 43 is inserted through the gap 32.

**[0041]** Figs. 5 to 11 show other embodiments of peel seam opening aids 1, wherein throughout the drawings, the same elements will be denoted by the same reference numerals. It is apparent to the person skilled in the art, that the embodiments shown are just a few exemplary embodiments. Various modifications are conceivable, in particular by combining elements shown in different embodiments, to thereby obtain further embodiments.

**[0042]** Fig. 5 shows a second embodiment of a peel seam opening aid 1. A central part 3 of the peel seam opening aid 1 shown in Fig. 5 comprises two rods 30 having a circular cross-section. The two rods 30 are mounted with a gap 32 between them to two mounting brackets 34 provided at either end of the rods 30. Further, a gripping element 2 in the form of a star-shaped knob is mounted to each mounting bracket 34. The gap 32 is configured to allow the bottom edge 43 or a corner region of the bottom edge 43 of a multichamber bag 4 (see Fig.

2 to 4) to pass therethrough.

**[0043]** Fig. 6 shows a third embodiment of a peel seam opening aid 1 similar to Fig. 1 with a central part 3 comprising two rods 30. In contrast to the embodiment shown in Fig. 1, in the embodiment shown in Fig. 6 the rods 30 are in the form of profile rods. The two rods 30 are mounted to two gripping elements 2 with a gap 32 between them, which gap 32 is configured to allow the bottom edge 43 or a corner region of the bottom edge 43 of a multichamber bag 4 (see Fig. 2 to 4) to pass therethrough. Generally, any kind of profile rod may be used, wherein profile rods as shown in Fig. 6, which have smooth surfaces bordering the gap 32 are advantageous to avoid damaging of the multichamber bag 4.

**[0044]** Fig. 7 shows a fourth embodiment of a peel seam opening aid 1 with a central part 3 and two gripping elements 2. In the embodiment shown in Fig. 7, the central part 3 is a one-piece element provided with the gap 32 in the form of an elongated slot. The central part 3 in one embodiment is an injection moulded one-piece element. The gripping elements 2 shown in Fig. 7 are in the form of cross-rods, which are inserted into through-holes provided on the central part 3 perpendicular to the longitudinal direction of the central part 3.

**[0045]** Fig. 8 shows an end of a central part 3 with a gripping element 2 of a fifth embodiment of a peel seam opening aid 1. The central part 3 shown in Fig. 8 comprises two rods 30 having a circular cross-section, wherein a gripping element 2 designed as a three-wing knob is mounted between the two rods 30. The three wings 20 are flat and offset about 120° from one another. One of the wings 20 is arranged between the two rods 30 and functions as a spacer.

**[0046]** Fig. 9 shows an end of a central part 3 with a gripping element 2 of a sixth embodiment of a peel seam opening aid 1. The central part 3 shown in Fig. 9 comprises two rods 30 having a circular cross-section, which are mounted to a mounting bracket 34. A gripping element 2 designed as a ball-shaped knob is mounted to the side of the mounting bracket 34 facing away from the rods 30.

**[0047]** Fig. 10 shows an end of a central part 3 with a gripping element 2 of a seventh embodiment of a peel seam opening aid 1. The central part 3 shown in Fig. 10 comprises two rods 30 having a circular cross-section, which are mounted to a mounting bracket 34. A gripping element 2 designed as a triangular knob is mounted to the side of the mounting bracket 34 facing away from the rods 30.

**[0048]** Fig. 11 shows an end of a central part 3 with a gripping element 2 of an eighth embodiment of a peel seam opening aid 1. The gripping element is a three-wing knob comprising a circular end cap 22 and three spherical wings 23 protruding from the end cap 22. The central part 3 shown in Fig. 10 comprises two rods 30 having a circular cross-section, which are mounted to the end cap 22.

**[0049]** In the embodiments shown in Figs. 1 to 6 and

8 to 11, the central part 3 comprises two rods 30 of the same design. In other embodiments, the central part comprises two rods that differ in design, for example a rod having a semi-circular cross-section as shown in Fig. 1 in one embodiment is combined with a profile rod as shown in Fig. 6.

## Claims

1. A peel seam opening aid for opening peel seams (46) of a multichamber bag (4) having a first end (41) with a port system (40) and an opposite second end (42) with a bottom edge (43), the peel seam opening aid (1) comprising two gripping elements (2) and an elongated central part (3) arranged between the two gripping elements (2), **characterized in that** the central part (3) is provided with an gap (32) extending in an axial direction of the central part (3) configured to allow the bottom edge (43) or a corner region of the bottom edge (43) to be inserted through the gap (32) from a first side to protrude at an opposite second side to enable rolling the multichamber bag (4) onto the central part (3).
2. The peel seam opening aid according to claim 1, **characterized in that** the size of the gap (32) is between 2 mm and 6 mm, in particular between 2 mm and 4 mm.
3. The peel seam opening aid according to claim 1 or 2, **characterized in that** the central part (3) comprises two rods (30) arranged with the gap (32) between them.
4. The peel seam opening aid according to claim 3, **characterized in that** the rods (30) have a circular or semi-circular cross-section or are in the form of profile rods.
5. The peel seam opening aid according to claim 3 or 4, **characterized in that** the gripping elements (2) are mounted between the two rods (30).
6. The peel seam opening aid according to claim 3 or 4, **characterized in that** the gripping elements (2) are mounted to end faces of the two rods (30).
7. The peel seam opening aid according to claim 1 or 2, **characterized in that** the central part (3) is a one-piece element provided with the gap (32) in the form of an elongated slot.
8. The peel seam opening aid according to claim 7, **characterized in that** the central part (3) is an injection moulded one-piece element.
9. The peel seam opening aid according to claim 8,

**characterized in that** the peel seam opening aid (1) is a one-piece element comprising the central part (3) and the gripping elements (2).

10. The peel seam opening aid according to any one of claims 1 to 9, **characterized in that** the gripping elements (2) are selected from a group comprising a two-wing knob, a multi-wing knob, a ball-shaped knob, a triangular knob, a star-shaped knob, a cylindrical knob, a knurled knob, and a cross-rod. 5  
10

11. A method for opening peel seams (46) of a multichamber bag (4) having a first end (41) with a port system (40) and an opposite second end (42) with a bottom edge (43) using a peel seam opening aid (1) according to any one of claims 1 to 8, **characterized in that** the bottom edge (43) of the multichamber bag (4) or a corner region of the bottom edge (43) is inserted through the gap (43) from a first side to protrude at an opposite second side and the multichamber bag (4) is rolled onto the central part (3) until a pressure in the multichamber bag (3) exceeds a sealing strength of the peel seams (46) and breaks them open. 15  
20  
25

12. The method according to claim 11, **characterized in that** the bottom edge (43) or corner region is inserted to protrude at the second side over a distance which is equal to or larger than the diameter of the central part (3). 30

35

40

45

50

55

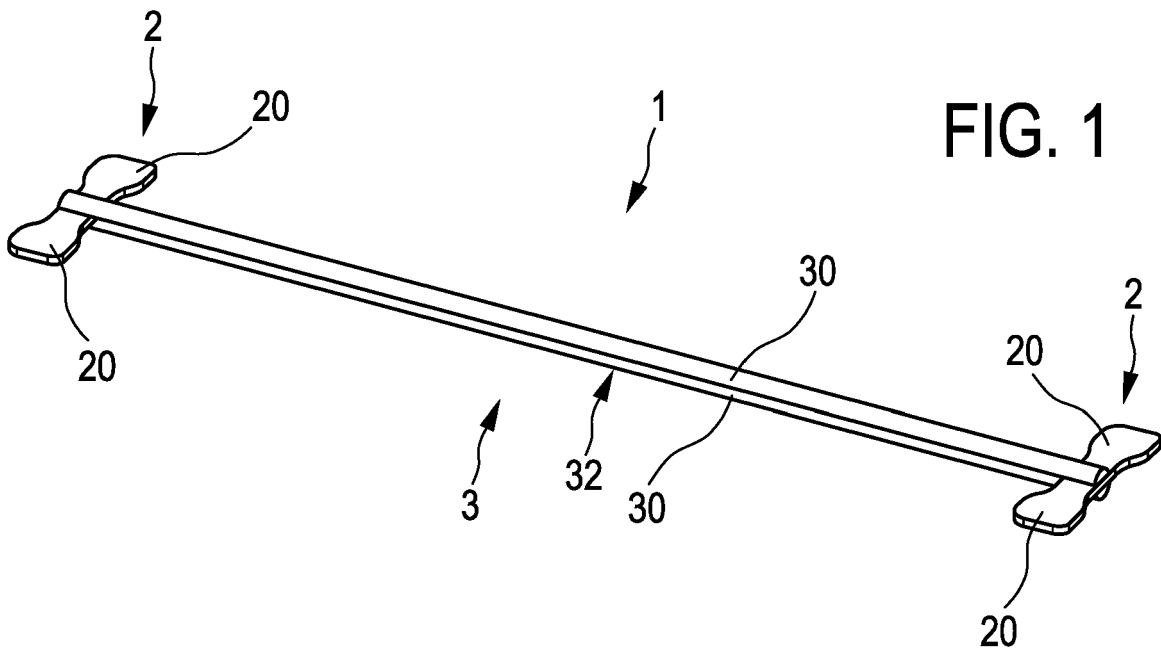

FIG. 1

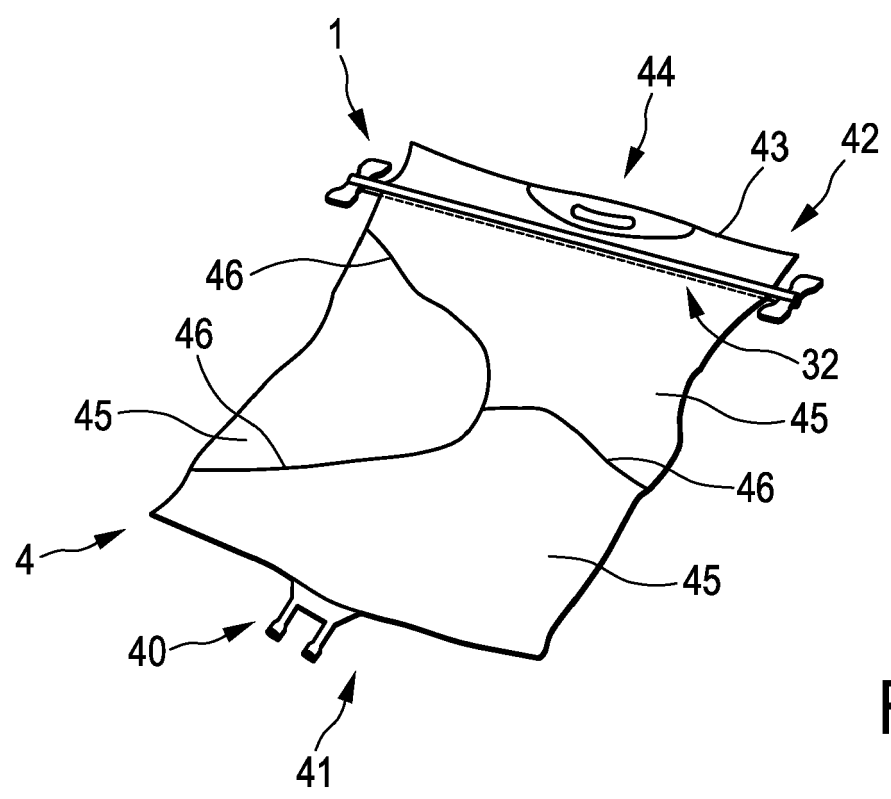

FIG. 2

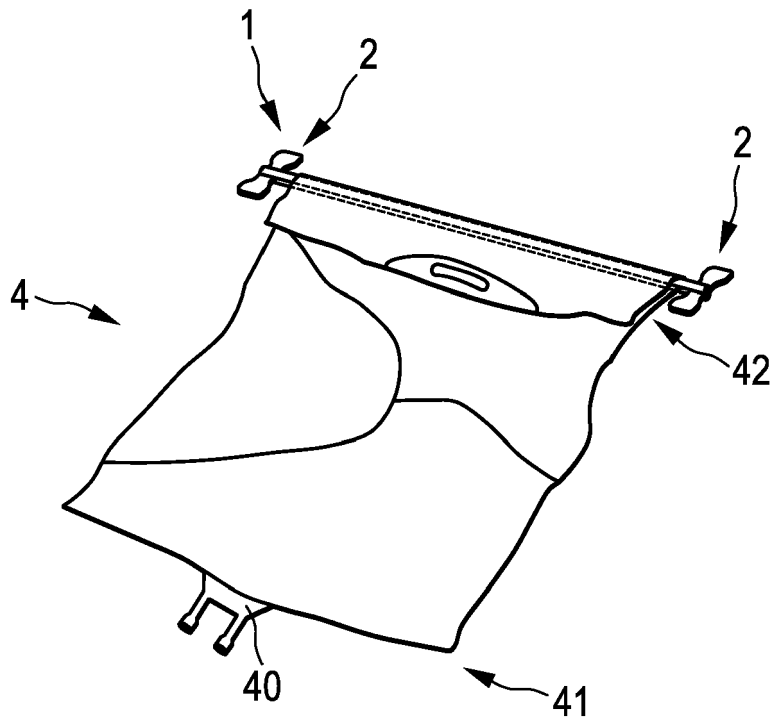

FIG. 3

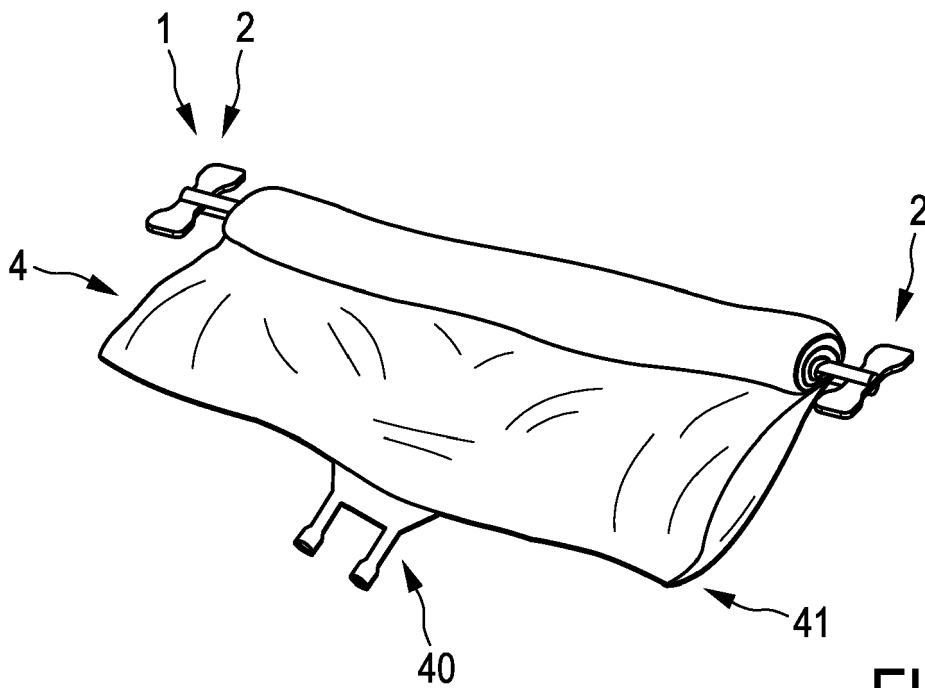
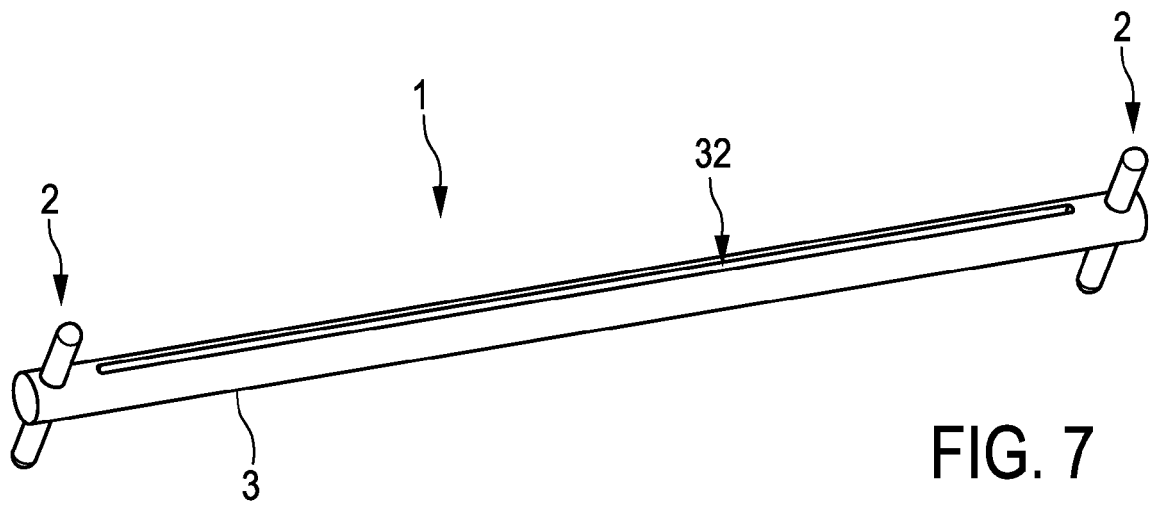
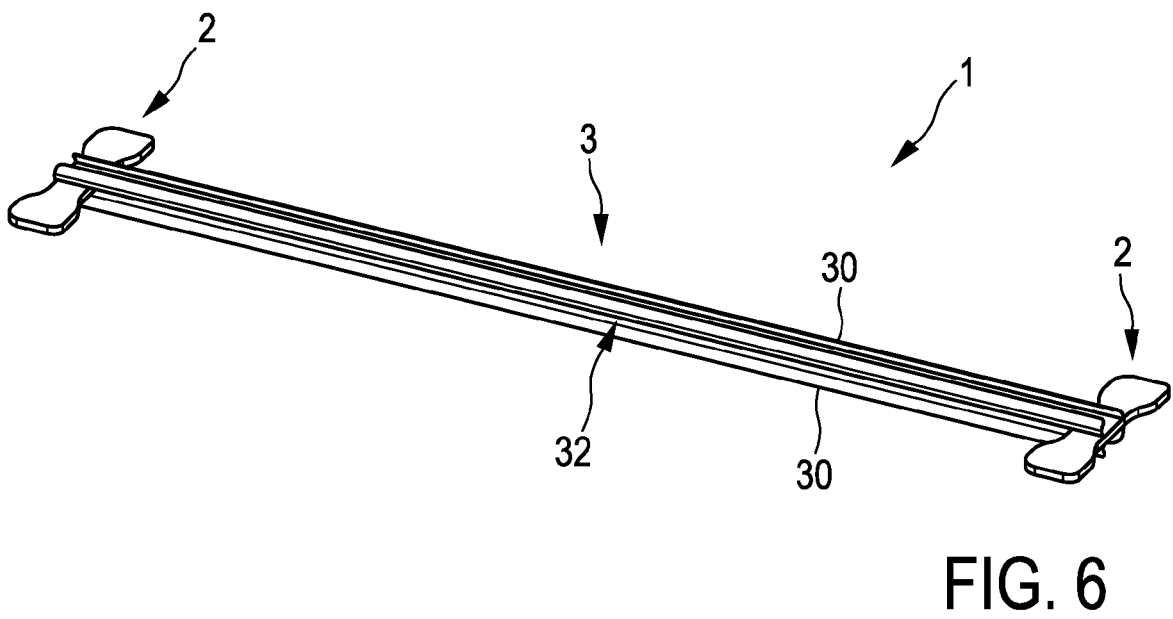
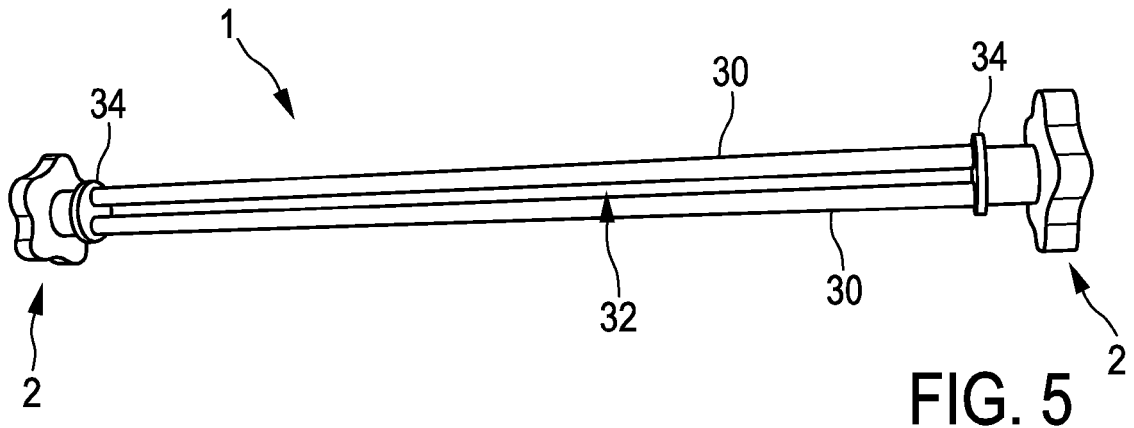
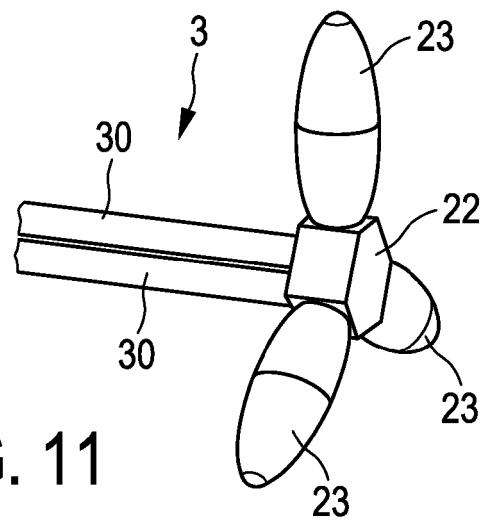
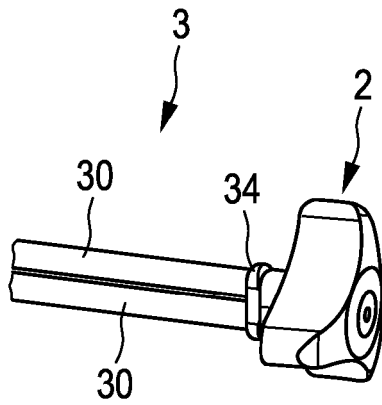
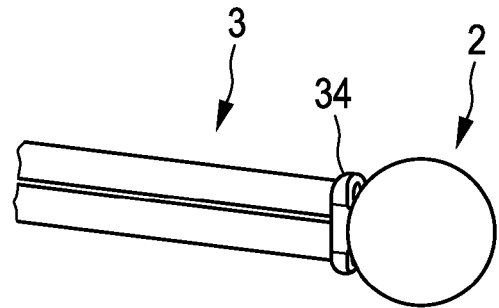
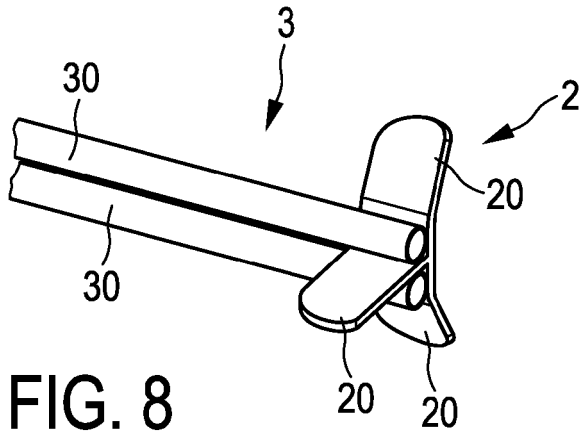

FIG. 4







EUROPEAN SEARCH REPORT

Application Number  
EP 21 19 2975

5

10

15

20

25

30

35

40

45

50

55

DOCUMENTS CONSIDERED TO BE RELEVANT			
Category	Citation of document with indication, where appropriate, of relevant passages	Relevant to claim	CLASSIFICATION OF THE APPLICATION (IPC)
X	DE 20 2011 107897 U1 (BOEHMER LUDWIG [DE]) 12 December 2011 (2011-12-12) * figures 1-4 *	1-12	INV. A61J1/16 A61J1/20 B65D35/28 B65D35/32
X	FR 2 926 795 A1 (GARCIA THIERRY [FR]) 31 July 2009 (2009-07-31) * figures 1-3, 6 *	1-4, 6, 10-12	
X	US 5 975 361 A (CORROW RICHARD N [US]) 2 November 1999 (1999-11-02) * figures 1, 2, 2a, 2b *	1-12	
X	US 2 492 594 A (RENOUF SIDNEY W B) 27 December 1949 (1949-12-27) * figures 1, 8-12 *	1-5	
X	CH 393 178 A (KOGA MOTOYUKI [JP]) 31 May 1965 (1965-05-31) * figure 12 *	1-5, 7, 10-12	
T	US 2007/029001 A1 (TROUILLY JEAN LUC [BE] ET AL) 8 February 2007 (2007-02-08) * figure 3 *		TECHNICAL FIELDS SEARCHED (IPC) A61J B65D
1 The present search report has been drawn up for all claims			
Place of search <b>The Hague</b>		Date of completion of the search <b>18 January 2022</b>	Examiner <b>Kroeders, Marleen</b>
CATEGORY OF CITED DOCUMENTS X : particularly relevant if taken alone Y : particularly relevant if combined with another document of the same category A : technological background O : non-written disclosure P : intermediate document		T : theory or principle underlying the invention E : earlier patent document, but published on, or after the filing date D : document cited in the application L : document cited for other reasons ..... & : member of the same patent family, corresponding document	

EPO FORM 1503 03.82 (P04C01)

ANNEX TO THE EUROPEAN SEARCH REPORT  
ON EUROPEAN PATENT APPLICATION NO.

EP 21 19 2975

5 This annex lists the patent family members relating to the patent documents cited in the above-mentioned European search report.  
The members are as contained in the European Patent Office EDP file on  
The European Patent Office is in no way liable for these particulars which are merely given for the purpose of information.

18-01-2022

Patent document cited in search report	Publication date	Patent family member(s)	Publication date
DE 202011107897 U1	12-12-2011	NONE	
FR 2926795 A1	31-07-2009	FR 2926795 A1 WO 2009109717 A1	31-07-2009 11-09-2009
US 5975361 A	02-11-1999	NONE	
US 2492594 A	27-12-1949	NONE	
CH 393178 A	31-05-1965	NONE	
US 2007029001 A1	08-02-2007	AT 493105 T AU 2006275435 A1 AU 2006275439 A1 AU 2006295338 A1 BR PI0614097 A2 BR PI0614521 A2 BR PI0614606 A2 CA 2616928 A1 CA 2617230 A1 CA 2617627 A1 CN 101277670 A CN 101287438 A CN 101351179 A DK 1909736 T3 DK 1909739 T3 EP 1909736 A2 EP 1909737 A1 EP 1909739 A1 ES 2358682 T3 ES 2525930 T3 HK 1121031 A1 HK 1121032 A1 IL 189196 A IL 189197 A JP 2009502435 A JP 2009502436 A JP 2009503549 A KR 20080035667 A KR 20080041229 A KR 20080043804 A NZ 565764 A NZ 565765 A PT 1909736 E PT 1909739 E US 2007029001 A1	15-01-2011 08-02-2007 08-02-2007 05-04-2007 09-03-2011 29-03-2011 05-04-2011 05-04-2007 08-02-2007 08-02-2007 01-10-2008 15-10-2008 21-01-2009 01-12-2014 21-03-2011 16-04-2008 16-04-2008 16-04-2008 12-05-2011 02-01-2015 17-04-2009 17-04-2009 27-09-2011 31-07-2011 29-01-2009 29-01-2009 29-01-2009 23-04-2008 09-05-2008 19-05-2008 25-06-2010 29-01-2010 23-12-2014 23-03-2011 08-02-2007

EPO FORM P0459

For more details about this annex : see Official Journal of the European Patent Office, No. 12/82

**ANNEX TO THE EUROPEAN SEARCH REPORT  
ON EUROPEAN PATENT APPLICATION NO.**

EP 21 19 2975

5 This annex lists the patent family members relating to the patent documents cited in the above-mentioned European search report.  
The members are as contained in the European Patent Office EDP file on  
The European Patent Office is in no way liable for these particulars which are merely given for the purpose of information.

18-01-2022

10

Patent document cited in search report	Publication date	Patent family member(s)	Publication date
		US 2007031976 A1	08-02-2007
		US 2007092579 A1	26-04-2007
		WO 2007016611 A2	08-02-2007
		WO 2007016615 A1	08-02-2007
		WO 2007037793 A1	05-04-2007
-----			

15

20

25

30

35

40

45

50

55

EPO FORM P0459

For more details about this annex : see Official Journal of the European Patent Office, No. 12/82

**REFERENCES CITED IN THE DESCRIPTION**

*This list of references cited by the applicant is for the reader's convenience only. It does not form part of the European patent document. Even though great care has been taken in compiling the references, errors or omissions cannot be excluded and the EPO disclaims all liability in this regard.*

**Patent documents cited in the description**

- US 2017101253 A1 [0004]