



(22) Date de dépôt/Filing Date: 2003/09/09

(41) Mise à la disp. pub./Open to Public Insp.: 2005/03/09

(51) Cl.Int.⁷/Int.Cl.⁷ F04B 39/16, F04D 29/00

(71) Demandeur/Applicant:
FUELMAKER CORPORATION, CA

(72) Inventeurs/Inventors:
CHAN, ANTHONY, CA;
ANTANASSOV, FILIP, CA;
RACKMAN, RALPH, CA;
MOJSOV, TOME, CA;
DEMALINE, TRACEY, CA

(74) Agent: FRENCH, DAVID J.

(54) Titre : COMPRESSEUR A GAZ AVEC SECHOIR ET COMMANDES D'EMISSIONS RADIOELECTRIQUES

(54) Title: GAS COMPRESSOR WITH DRIER AND RADIO EMISSION CONTROLS



(57) Abrégé/Abstract:

A gas compressor unit according to the invention includes a single gas desiccant bed and condenser (which is inactive during the compression stage) inserted into the gas flow path of the compression cycle. In the case of a multi-stage compressor, the single gas desiccant bed is inserted between preferably the first and second stages. Moisture absorbed into this bed is periodically removed by exposing the bed to a regeneration cycle. The regeneration cycle employed is based on the closed re-circulation of gas present in the compressor and the desiccant bed itself, as well as other gas present in the re-circulation loop, when the unit suspends the vehicle-filling operation. Moisture removed from the desiccant bed is condensed and evaporated into the environment through a semipermeable membrane. The motor and motor controller are located with the compressor to minimize electro-magnetic emissions.



Abstract

A gas compressor unit according to the invention includes a single gas desiccant bed and condenser (which is inactive during the compression stage) inserted into the gas flow path of the compression cycle. In the case of a multi-stage compressor, the single gas desiccant bed is inserted between preferably the first and second stages. Moisture absorbed into this bed is periodically removed by exposing the bed to a regeneration cycle. The regeneration cycle employed is based on the closed re-circulation of gas present in the compressor and the desiccant bed itself, as well as other gas present in the re-circulation loop, when the unit suspends the vehicle-filling operation. Moisture removed from the desiccant bed is condensed and evaporated into the environment through a semipermeable membrane. The motor and motor controller are located with the compressor to minimize electro-magnetic emissions.

TITLE: Gas Compressor with Drier and Radio Emission Controls

FIELD OF THE INVENTION

This invention relates to the compression of gases. More particularly, it relates
5 to the compression of natural gas and/or hydrogen for use in vehicles propelled by such
gases. Specifically, it relates to an apparatus and methods for removing moisture vapor
as part of the compression procedure and separating removed moisture from
contaminants therein. It also relates to minimizing the release of electromagnetic
radiation.

10 BACKGROUND OF THE INVENTION

It is known to remove moisture from gas in order to store such gas for use in a
motor vehicle. Moisture is also removed from compressed gases for a variety of other
applications. Typically, during the gas compression cycle the gas being compressed is
passed over a desiccant bed which effects the removal of moisture from the gas.
15 Eventually, the desiccant bed will saturate. A moisture sensor may be employed to
detect the amount of moisture present in the gas exiting the compressor, sensing when
the measured moisture content at the output of the compressor rises beyond a permissible
range, above an upper limit. Alternately, a drying bed may be employed for a
predetermined period of time. In either case the compression of gas is eventually
20 interrupted to allow the system to enter a regeneration stage for recharging the desiccant
bed.

The technology for drying gas streams is well established. It includes absorption
and condensation methods and the use of membrane separation systems. Examples of
25 these technologies, used separately and in combination are United States patent Nos.
5,034,025; 5,071,451 and 5,240,472 as well as the prior art referred to therein.

Existing compressors of this type have employed gas drying arrangements that operate on a continuous basis, using a two-bed system. Examples of this type of technology include US patent 6,117,211.

5 The present invention addresses the object of compressing natural gas with a reduced amount of moisture being present in the compressed gas by employing gas drying arrangements that operate on a dis-continuous basis, using a single-bed system.

In the treatment of gas streams, de-watering processes generate extracted water that may contain traces of contaminants originating from the principal stream. In the case
10 of natural gas, these contaminants include hydrogen sulphide, sulphur dioxide and mercaptans. Disposal of water containing contaminants of this type can be subject to environmental restraints.

The extracted water being produced cannot be released locally into the
15 environment because of the contaminants present therein. Apart from issues relating to hazards, even trace smells of organic or sulphurous components from a natural gas stream would suggest to a consumer that a leak existed in the compressor system.

It is an object of this invention to address the convenient disposal of separated
20 water under these circumstances.

It is a further object of this invention to minimize the release of electromagnetic radiation during operation of the compressor system.

The invention in its general form will first be described, and then its implementation in terms of specific embodiments will be detailed with reference to the
25 drawings following hereafter. These embodiments are intended to demonstrate the principle of the invention, and the manner of its implementation. The invention in its

broadest and more specific forms will then be further described, and defined, in each of the individual claims which conclude this Specification.

SUMMARY OF THE INVENTION

According to the present invention in one aspect, a compressor for a gas which normally operates on a gas compression cycle is provided with a gas drier stage comprising a single desiccant bed located in-line with the flow of gas passing through the compressor during the gas compression cycle. Also located in-line with such gas flow is a condenser which, during the compression cycle, is inactive. The temperatures of the desiccant bed and condenser are both controllable, preferably by electrical means. During the compression cycle, such temperature controls are preferably inactive. However, upon entering into a regeneration cycle, the gas bed is heated and the condenser is cooled.

During the regeneration cycle, gas trapped within the compressor, desiccant bed and condenser is switched by valve means from passing from the compressor outlet through the delivery line to being circulated in a closed loop through such components, serving as a sweep gas. Circulation is effected at a low flow rate by reducing the speed of the compressor motor.

In this process water evolves from the desiccant bed, raising the moisture content of the circulating gas. The desiccant bed is heated at this stage to enhance its release of moisture. The released water, in vapor form, is then carried by the gas flow to the condenser where it condenses due to the low temperature condition maintained within the condenser. Circulating gas exiting the condenser leaves the condenser in a cooled, vapor saturated, condition. By the time of the circulating gas reaches the heated desiccant bed, its temperature has been raised and the gas is no longer vapor saturated.

The heated circulating gas is therefore able to absorb further moisture from the desiccant bed as it passes over such bed.

In order to dispose of water condensing within the condenser such water is directed, preferably flowing under gravity, into contact with a semi-permeable
5 membrane which allows the water to evaporate. At the same time, aromatic compounds present within the condensate are retained by the membrane within the condenser. To enhance the rate of evaporation and flow of water through the semipermeable membrane, an external fan and optional heater element are may be preferably positioned to circulate warm air past the membrane surface.

10

It is important to note that the condenser, according to the invention, is located in-line with the gas flow during the compression cycle. This exposes the condenser and semipermeable membrane to an elevated pressure condition. In a preferred variant of the invention, the compressor is a multi-stage compressor and the desiccant bed and
15 condenser are positioned in-line between the first and second stages of the compressor. Thus, although the condenser is exposed to an elevated pressure condition, this is not the final, maximum pressure produced by the compressor. Rather, it is an intermediate pressure arising after only the first stage of compression.

This limitation on the pressure to which the condenser is exposed is particularly
20 significant in the preferred embodiment of the invention wherein the condenser is directly connected to a semi-permeable membrane through which condensed water is allowed to evaporate into the environment. Such membranes are only capable of withstanding a modest pressure differential. In the case of a multistage compressor, the pressure developed between the first and second stage is not so high as to preclude use
25 of such a semi-permeable membrane as a means to dispose of water condensate. A preferred form of membrane is tubing made of Proton Energy Membrane (PEM).

Thus, according to this preferred embodiment, condensed water accumulating in the condenser is directly, or eventually, disposed of by release into the environment through the semi-permeable membrane. Use of such a membrane ensures separation and retention of complex odorous molecules that may be present in the water condensate, with only pure water being released into the environment.

Once the desiccant bed has been recharged, heating for the bed is terminated. As well, chilling of the condenser and heating for the semi-permeable membrane, if employed, are terminated. Thereafter the valve means is actuated to reconnect the outlet stage of the compressor to the delivery line. The compressor motor is then speeded up to resume the compression cycle and the inlet to the supply line automatically reopens.

In a further preferred variant, the compressor is contained within a sealed metal casing. Supply gas enters the interior volume of this casing through a check valve and is drawn into the compressor from the crank-portion of this interior volume. Also located within the casing is a variable speed motor, and preferably control circuitry for delivering current to the motor that will effect variable speed operation. In this preferred scenario, the motor is an alternating current induction motor, and the control circuitry produces an alternating current signal of varying frequency, whereby the speed of the motor is varied in accordance with system requirements.

As described above, the outlet from the compressor is connected through an electronically controlled valve to the delivery line which carries compressed gas off to a storage reservoir during the compression cycle. When the compressor ceases operating in compression mode, the electronically controlled delivery valve switches the flow of gas from the delivery line into the interior volume of the casing cavity. The resulting drop of pressure in the delivery line causes a check valve at the external

reservoir, which contains high pressure gas, to close. The compressed gas trapped in the delivery line then "blows down" into the interior volume of the casing, producing a pressure condition that is moderately elevated above that of the supply line pressure eg 30-60 psi. The check valve at the supply line inlet to the interior volume then
5 closes as the source gas pressure is only of the order of one-half to two psi.

With output of the compressor redirected into the casing volume, the trapped gas is now capable of circulating in a closed loop through the compressor, desiccant bed, condenser, and casing volume. Circulation of the gas for this closed loop is effected by operating the motor at a relatively low speed. The speed of the motor is
10 preferably adjusted so that the circulating gas passing through the condenser is substantially fully chilled when it exits the condenser. This maximizes the efficiency of transferring moisture from the desiccant bed to the condenser but is only a preferred mode of operation.

It is a further preferred feature of the invention that not only is the electrical
15 motor operating the compressor mechanism contained within the same casing as the compressor, but also the control circuitry for delivering power to the motor is contained within the casing. An advantageous result achieved by this arrangement is that electromagnetic emissions arising from current being delivered from the motor controller to the motor is confined within the metallic casing.

20 The control circuitry may be delivered current at 300 volts through a sealed penetration of the casing wall. The circuitry operates to create alternating current having a frequency of on the order 30 kilocycles. The electrical power delivered to the motor provides current, at a maximum level, of on the order of 30 amps. The electromagnetic radiation from the wiring extending between the control circuitry of
25 the motor carrying a such current at such a frequency is a strong source of electromagnetic radiation. By confining this wiring to within the metallic casing,

electromagnetic radiation from the zone a source is shielded from entering into the environment.

The foregoing summarizes the principal features of the invention and some of its optional aspects. The invention may be further understood by the description of the preferred embodiments, in conjunction with the drawings, which now follow.

SUMMARY OF THE FIGURES

Figure 1 is a pictorial representation of a gaseous fuel motor vehicle parked in a garage having a home refueling appliance according to the invention mounted on its inner wall.

Figure 2 is a partial cutaway cross-sectional sideview of the compressor/motor assembly within its immediate case. This compressor casing contains the motor, a blow-down volume, and the motor control circuitry. Also shown is an additional, outer case or shroud to contain cooling air flow.

Figure 3 is a schematic for the basic components of the appliance showing besides the motor and compressor the desiccant bed, the main logic controller, the motor control circuitry and various sensors.

Figure 4 is a schematic variant of Figure 3 showing gas flow during the compression cycle.

Figure 5 is a schematic as in Figure 4 showing the basic flow diagram of the appliance during the regeneration cycle wherein the desiccant bed is recharged.

Figure 6 is an enlarged schematic depiction of the desiccant bed during the regeneration cycle wherein the semi-permeable membrane is in the form of a tube through which water condensate is allowed to enter under gravity.

5 DESCRIPTION OF THE PREFERRED EMBODIMENT

In Figure 1 the home refueling appliance 1 is shown mounted on a garage wall with the high-pressure discharge or delivery hose 37 connected to a car, the inlet or supply hose 49 providing a source of gas 2, and the electrical cord 4 plugged into a standard household receptacle.

10 Referring to Figures 2 and 3, the compressor 5, motor 27 and motor control circuitry 45 are all located within the casing 26, (counting the compressor block as part of the casing), which is in turn, surrounded by an outer shroud 43. According to the invention a variable speed electronic motor controller 45, which supplies current to the electrical motor 27, is preferably located within the totally contained
15 environment of the motor/compressor assembly. This sealed environment is provided by the same metal casing 26 that surrounds the motor and compressor parts. The motor control circuitry 45 is, in particular, located in the blow-down volume 14, sealed entirely within the casing 26. The metallic wall of the casing 26 acts as heat sink for the heat produced by the motor control circuitry 45 and as a shield for
20 outgoing electromagnetic emissions arising from wiring extending between the motor 27 and motor controller 45.

As shown in Figure 3, the main logic controller 46, fed power from a power supply 47, is able to activate the motor 27 and govern its speed through motor control circuitry 45. Signals between the main logic controller 46 and motor control circuitry
25 45 penetrate the casing 26 at a sealed entry point 44. The command logic circuitry 46 sends and receives commands and data through digitally encoded signals transmitted

along optical fibers. This minimizes the electrical penetrations made into the interior 14 of the metal cavity of the casing 26 which contains natural gas in a partially pressurized condition.

Figure 3 depicts the unit operating in compression mode. In Figure 3 line gas 5 2 which may contain contaminants 8, enters the interior volume 14 of the casing 26 from which it drawn into the first of a series of four compression stages 28, 32, 33, 34. The line gas 2, which has a pressure of between one-half and two psi is drawn into the interior volume 14 by the suction created by the first compression stage 28. A line gas pressure sensor 21 detects the line gas pressure, providing a signal to the 10 main logic controller 46.

On leaving the first stage 28, the gas 2 passes through a dessicant bed contained within a absorption chamber 29. This bed of desiccant material 7, such as alumina or zeolite, contained within chamber 29 adsorbs the moisture in the gas 2, including at least some of the contaminants 8. Upon exiting the absorption chamber 15 29, the dried gas continues into the volume of a condenser 30 which is, at this stage, passive. Exiting the condenser 30 through conduit 55, the gas 2 proceeds to the next, second stage 32 of the compressor 5. The flow of gas in this compression cycle is shown in Figure 4.

As shown in Figure 5, and in greater detail in Figure 6, the desiccant 7 is 20 regenerated by being exposed to a sweep gas 13 originating from the desiccated gas stream trapped in the compressor 5, motor 27, desiccant bed 7 and condensor 30 when the compression cycle is terminated. This trapped gas serves as a sweep gas. As shown in Figure 5 the sweep gas 13 is drawn through the absorbent bed 7 by the slow operation of the compressor 5. Moisture in the adsorbent bed 7 is encouraged 25 to vaporize into the sweep gas 13 by its dry condition, as described further below, and the additional supply of heating to the absorbent bed.

Upon exiting the bed 7 the gas flows into condenser 30 which contains, heat-exchange surfaces. These heat-exchange surfaces are preferably cooled by an electrical-actuated cooling block 53 operating on the basis of the Peltier effect. Cooled, circulating sweep gas 13, which has now been de-moisturized in the
5 condenser 30, then passes into a return conduit 55 that leads to the second stage 32 of the compressor. The slow operation of the motor 27 and compressor 5, causes this sweep gas 13 to circulate endlessly until the regeneration cycle is terminated.

To speed the regeneration process and assist in recovery of the water subsequently, a thermostatically controlled electrical element 52 warms the desiccant
10 7. The warmed, moisturized sweep gas more effectively releases moisture as it passes through the condenser 30.

Liquified water 54 accumulates in the bottom of the condenser 30 as a condensate, below the level of the return conduit 55 within the condenser. The condensed water 54 will contain some residual contaminants 8a. This water
15 condensate 54, including residual contaminants 8a present therein, may be simply accumulated and collected or it may then be passed to a separation chamber 31 where it is presented to a semi-permeable membrane 61. The semipermeable membrane 61 allows only the penetration of water as the permeate. On the other side of the membrane 61, water diffusing therethrough evaporates. This process may be
20 accelerated by a circulating airflow originating from a fan 42. In this case the shroud 43 serves to duct a constant air flow over the membrane 61. Optional the air flow in the vicinity of the membrane may be heated by a membrane heater 56.

The circulating airflow 60 from the fan 42 may also be used to cool the condenser 30, preferably using separate ducting (not shown).

As water diffuses through the membrane 61, some contaminants 8a may accumulate on the interior surface of the membrane 61. Eventually, the rate of diffusion may drop to a level where the membrane 61 must be cleaned or replaced.

In the foregoing description the semi-permeable membrane 61 could be in the form of a plate fitted as part of the wall of the separation chamber 31. Figure 6 shows a preferred variant in which the semi-permeable membrane is shown as a tube 61. This tube 61 is preferably formed of semi-permeable hydroscopic ion exchange membrane material. Membranes in the form of tubes made of modified Teflon(TM) have been found suitable for this application, showing life-times of practical duration.

It is noted that the absorbent chamber 29 and condenser 30 are contained within the high pressure zone of the compressor 5, between the first stage 28 and the second stage 32. The pressure in this zone is only in the order of 200 psi. It has been found that, at these pressure levels, the semi-permeable membrane 61 in tubing format can extend outside this pressurized zone, relying on simple couplings 57 to seal the connection between the tubing 61 and the condenser chamber 30. The use of the multistage compressor especially facilitates this arrangement.

Further components include an inlet filter 22, a high pressure transducer 24, a pressure relief valve 25 leading to a vent opening 50, a burst disc 35 in the fourth stage 34 to relieve excessive over-pressure, an in-line breakaway connector 36, the vehicle connection nozzle 38, a gas-detecting sensor 39, an air flow sensor 40, and an ambient air temperature sensor 41.

CONCLUSION

The above disclosed embodiments are only exemplary. The invention in its broadest, and more specific aspects, is further described and defined in the claims which now follow.

5 These claims, and the language used therein, are to be understood in terms of the variants of the invention which have been described. They are not to be restricted to such variants, but are to be read as covering the full scope of the invention as is implicit within the invention and the disclosure that has been provided herein.

THE EMBODIMENTS OF THE INVENTION IN WHICH AN EXCLUSIVE PROPERTY OR PRIVILEGE IS CLAIMED ARE DEFINED AS FOLLOWS:

1. A compressor system for gas which normally operates on a gas compression cycle, said system comprising:

5 1) a compressor having at least a first stage inlet through which passes a flow of gas being compressed from a gas supply inlet to a gas delivery outlet, at the outlet of the compressor, for supplying gas to a delivery line;

2) a gas drier stage comprising a desiccant bed located in-line with the flow of gas passing through the compressor during the gas compression cycle;

10 3) a condenser also located in-line with the flow of gas passing through the compressor during the gas compression cycle which condenser, during the compression cycle, is normally inactive;

4) temperature control means to control the temperatures of the desiccant bed and condenser which means are, during the compression cycle, inactive but, upon
15 entering into a regeneration cycle, such means being actuatable to cause the desiccant bed to be heated and the condenser to be cooled;

5) valve means for switching the flow of gas from the delivery outlet into the interior volume of the casing,

whereby, during the regeneration cycle, gas trapped within the compressor, desiccant
20 bed and condenser is redirected from the outlet of the compressor for circulation in a closed loop through such components to permit water evolved from the desiccant bed to be carried by the circulating gas to the condenser where it condenses due to the low temperature condition maintained within the condenser.

2. A compressor system as in claim 1 wherein the compressor is a multi-stage
25 compressor having at least first and second stages, and the desiccant bed and

condenser are positioned in-line between the first and second stages of the compressor.

3. A compressor system as in claim 2 wherein the condenser produces water as a condensate and further comprising a semi-permeable membrane through which
5 condensed water is allowed to evaporate into the environment.

4. A compressor system as in claim 1 wherein the compressor comprises a sealed metal casing with an interior volume connected to said gas supply inlet and to the first stage compressor inlet, said interior volume further comprising

10 1) a variable speed motor contained therein and connected to drive said compressor, and

2) a supply valve at said gas supply inlet that closes when the pressure in the interior volume exceeds the supply gas pressure,

whereby, by activation of said supply valve, gas within the interior volume of the
15 casing may be drawn-in by the first stage compressor from either said gas supply inlet or from said compressor outlet.

5. A compressor system as in claim 4 comprising a main logic controller connected to motor control circuitry to effect variable speed operation of the motor
20 for operating the motor and compressor at a reduced speed, said speed being adjusted during regeneration so that the circulating gas passing through the condenser is substantially fully chilled when it exits the condenser whereby the efficiency of transferring moisture from the desiccant bed to the condenser is elevated.

6. A compressor system as in claim 4 comprising a main, logic controller
25 connected to motor control circuitry located within the casing for delivering current to the motor to effect variable speed operation, said control circuitry being connected

to said motor through wiring that is shielded by said casing whereby electromagnetic emissions arising from current being delivered from the controller to the motor is not transmitted outside the metallic casing.

7. A compressor system as in claim 6 wherein the motor is an alternating current
5 induction motor, and the motor control circuitry produces an alternating current
signal of varying frequency, whereby the speed of the motor is varied in accordance
with such varying frequency.

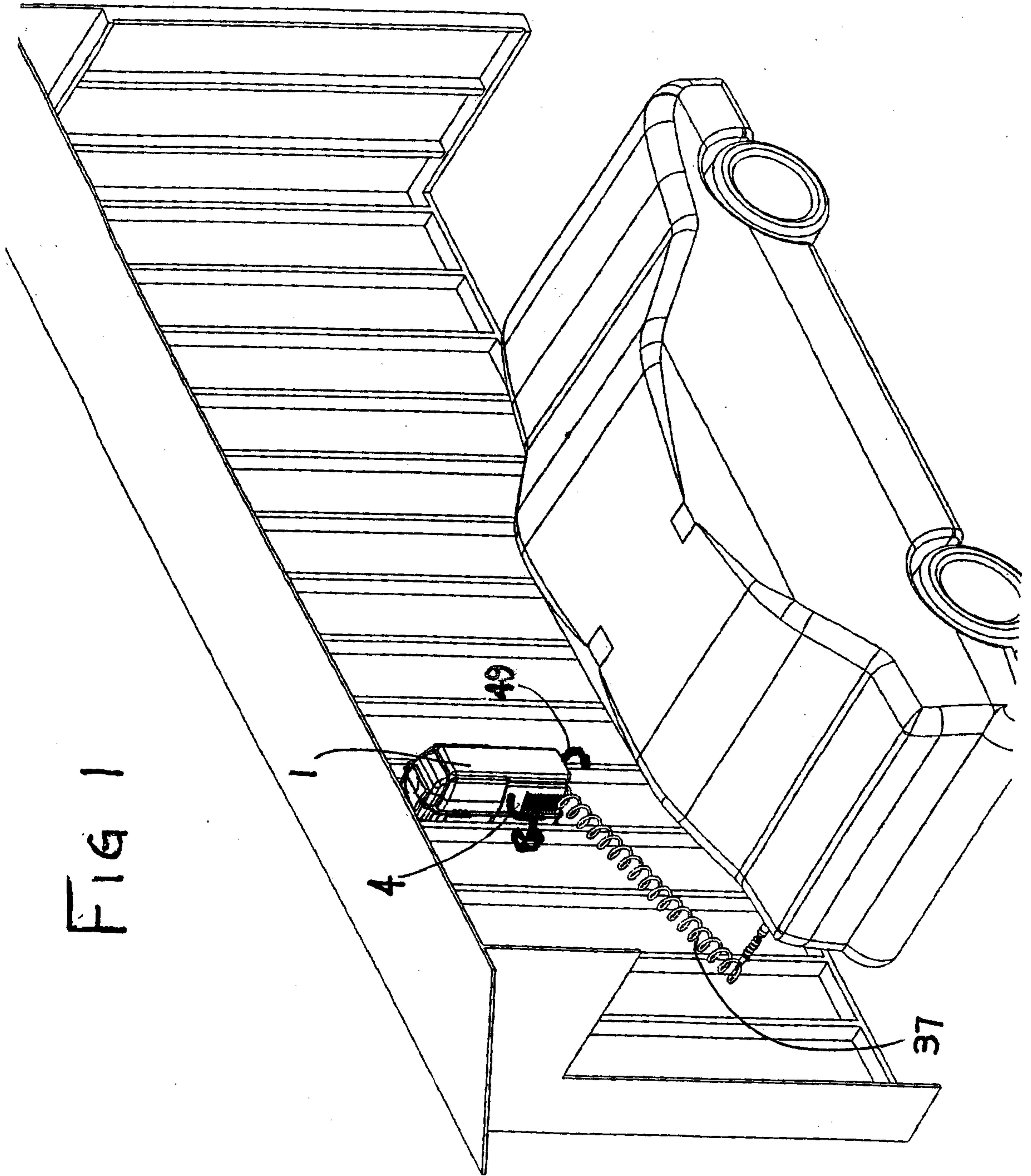

FIG 1

FIG 2

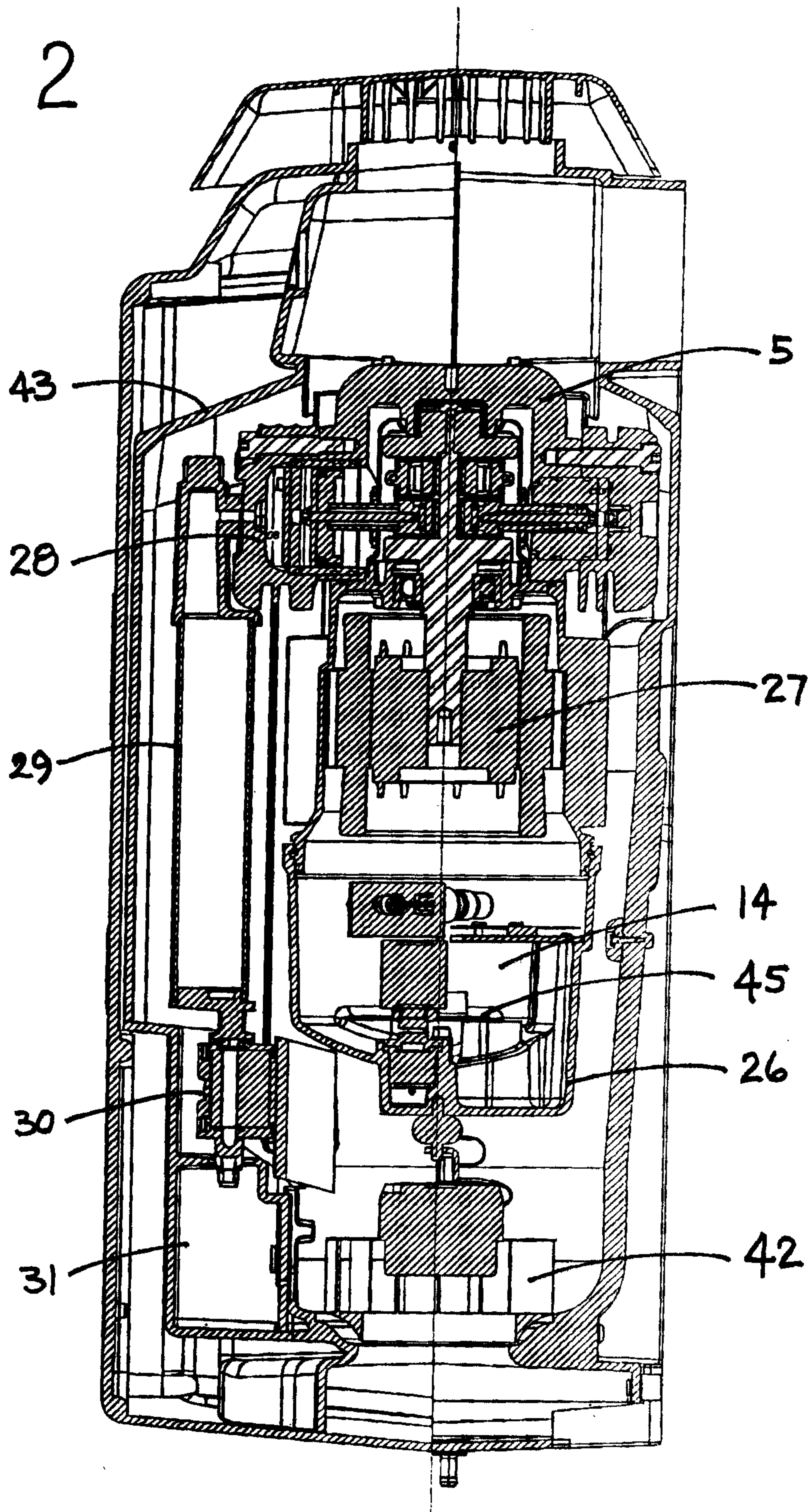

FIG 3

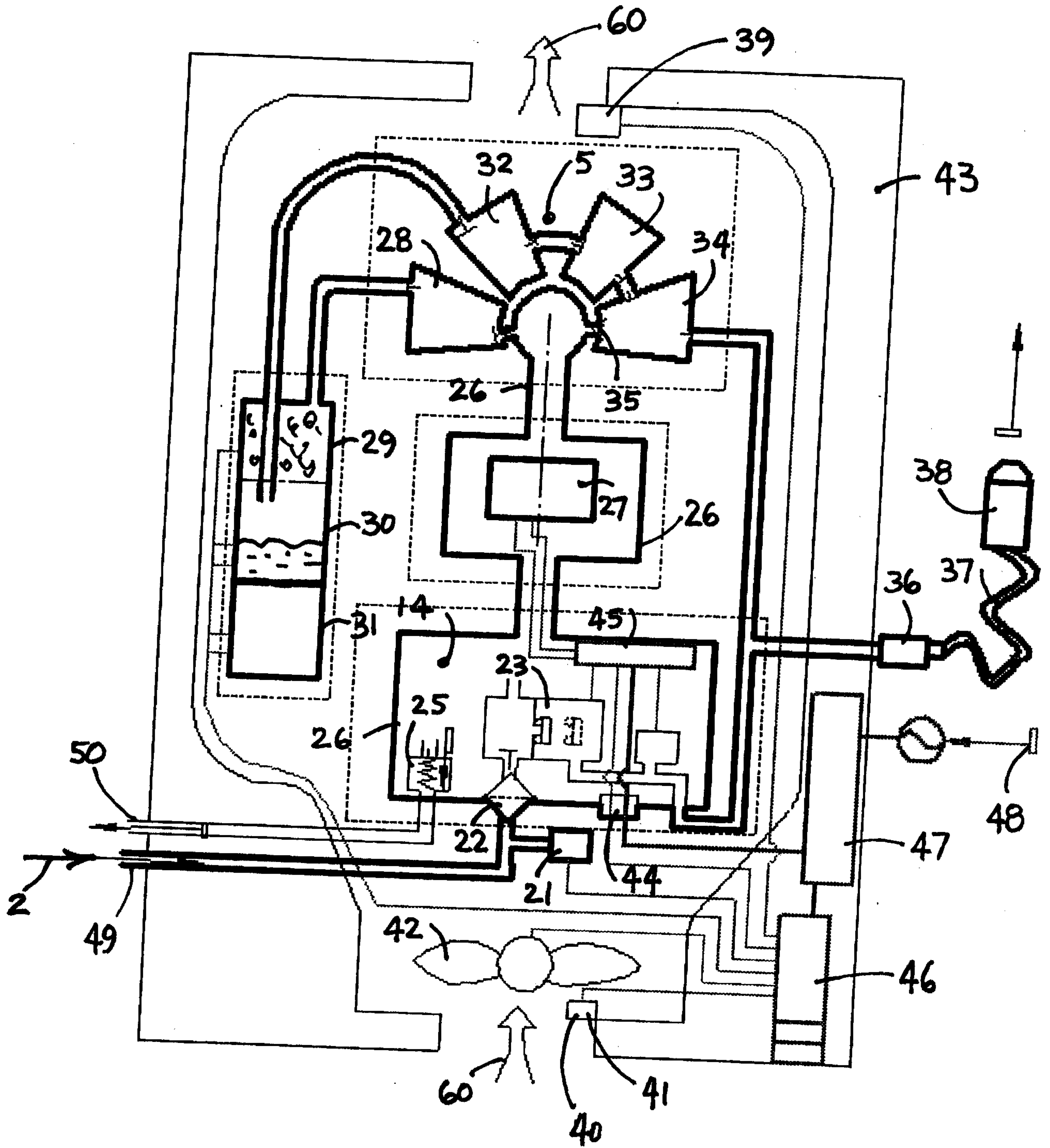

FIG 4

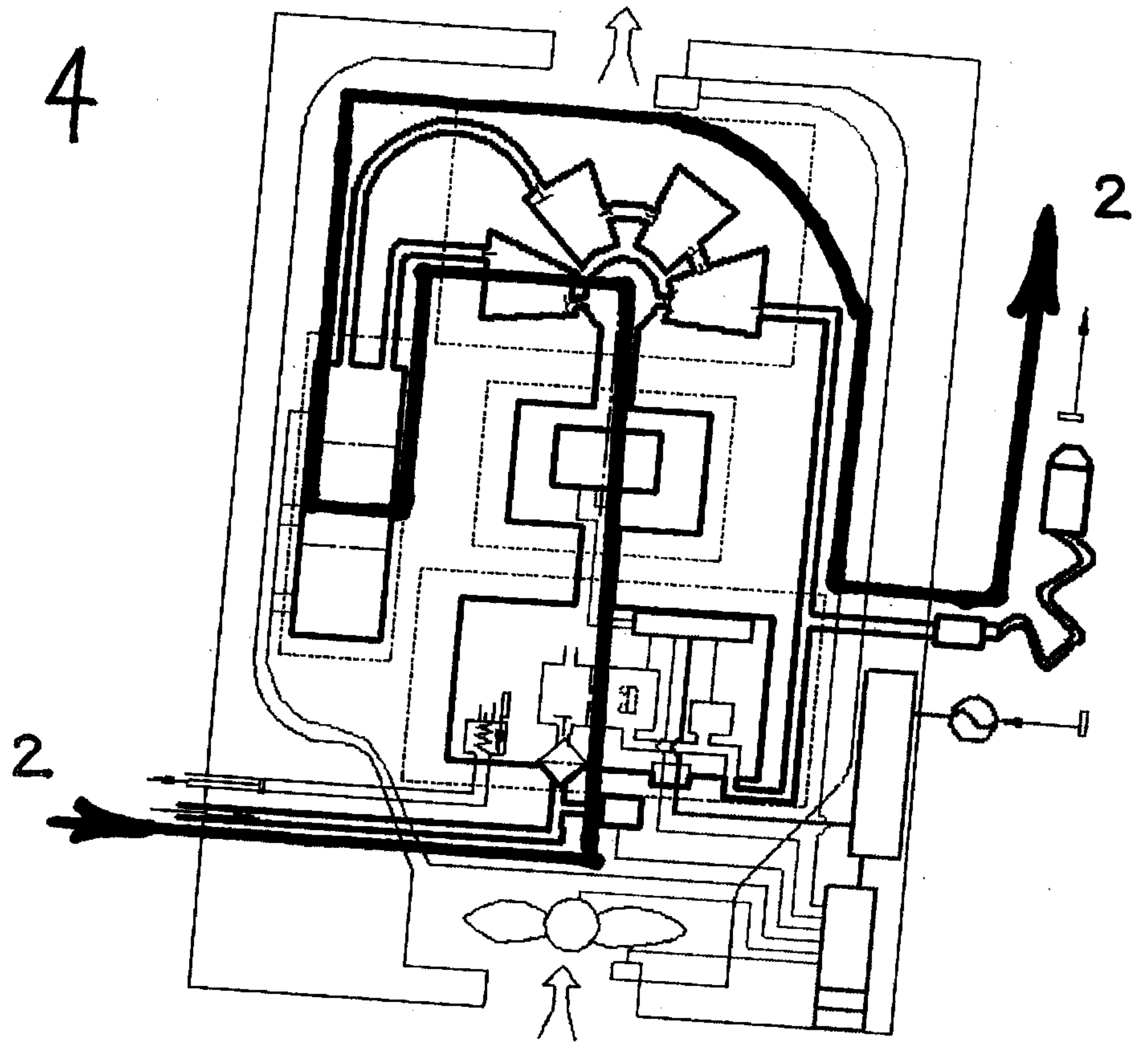

FIG 5

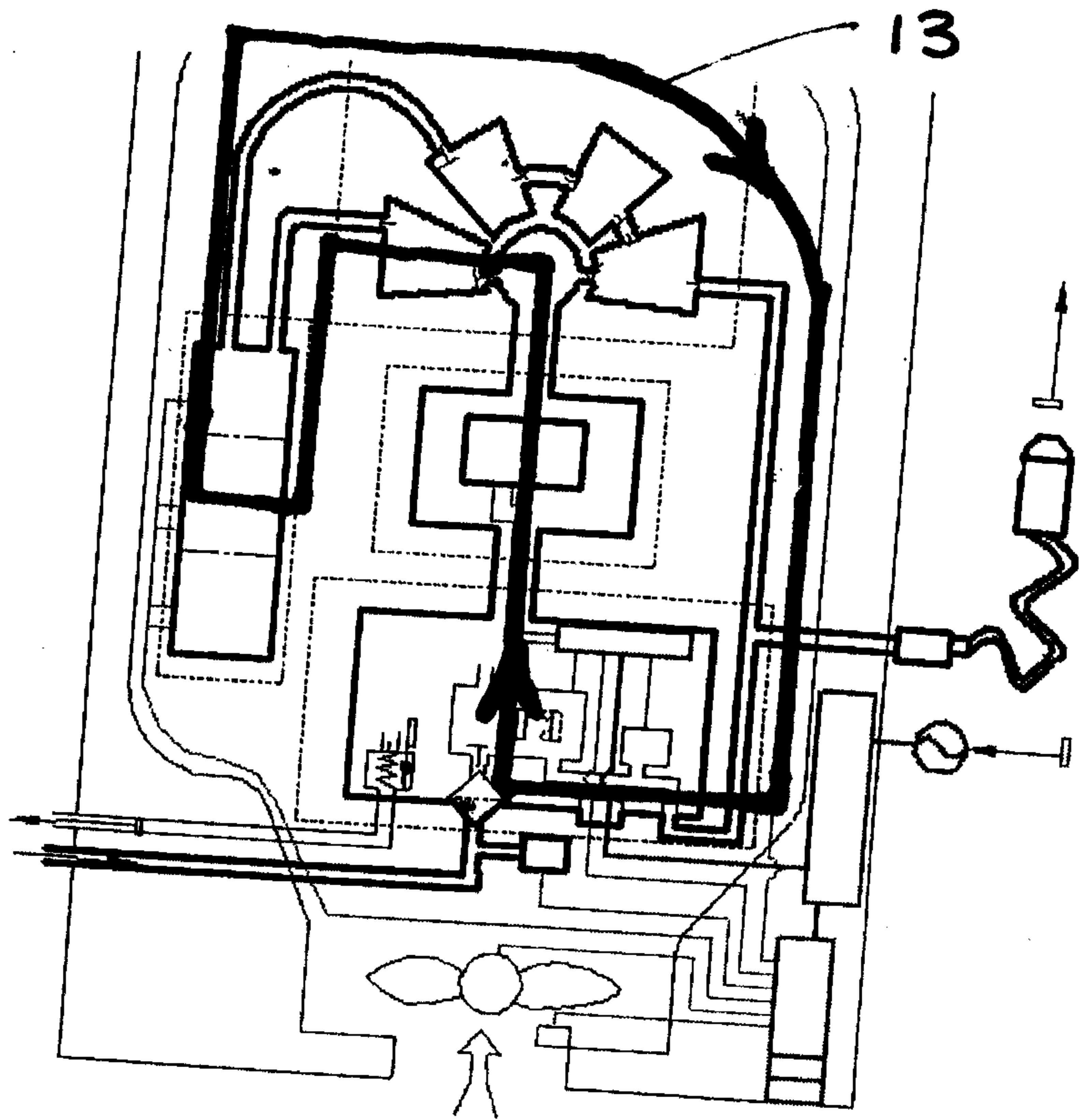

FIG 6

