

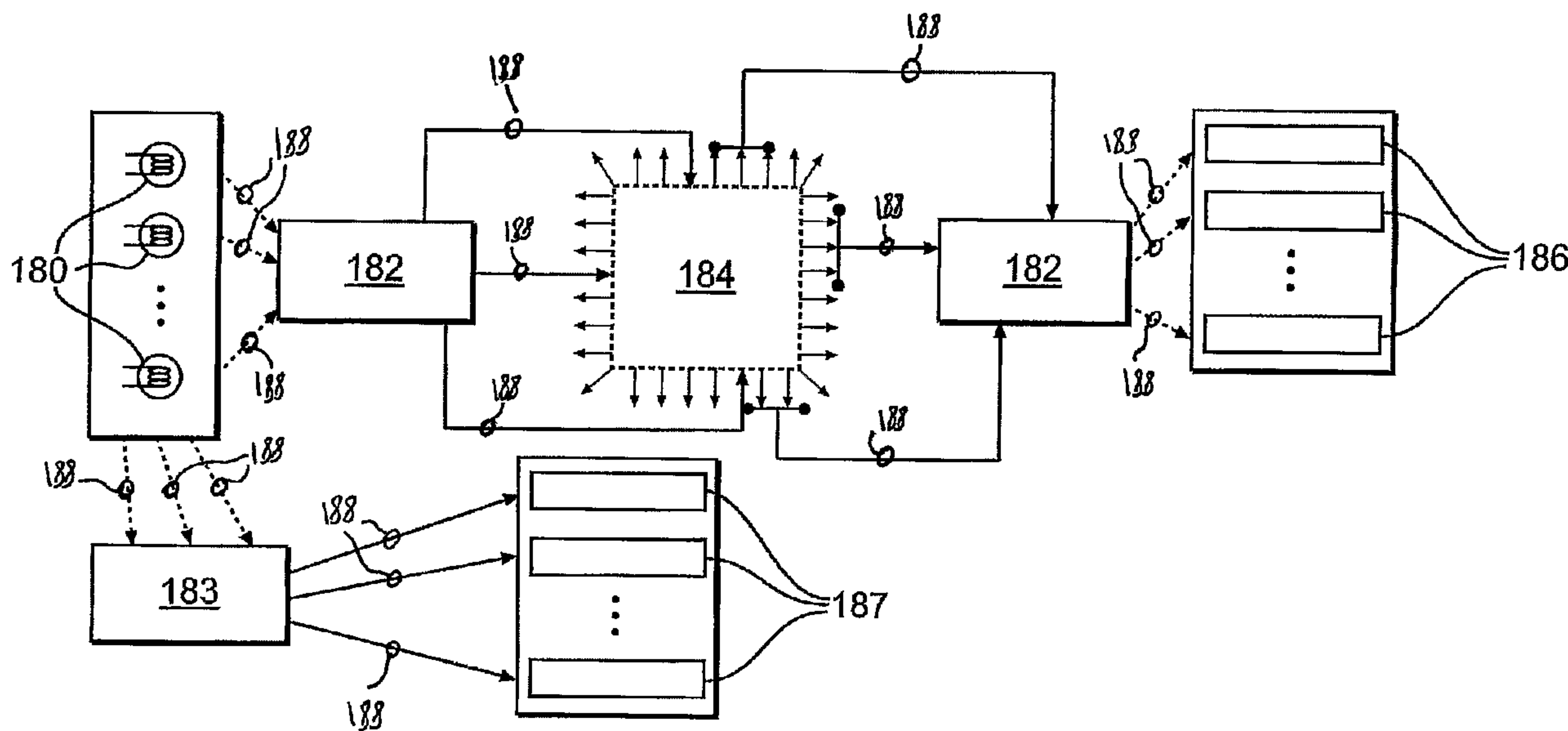

(86) **Date de dépôt PCT/PCT Filing Date:** 2007/01/24
 (87) **Date publication PCT/PCT Publication Date:** 2007/08/02
 (45) **Date de délivrance/Issue Date:** 2014/04/29
 (85) **Entrée phase nationale/National Entry:** 2008/07/23
 (86) **N° demande PCT/PCT Application No.:** IB 2007/000153
 (87) **N° publication PCT/PCT Publication No.:** 2007/085935
 (30) **Priorité/Priority:** 2006/01/26 (US11/307,171)

(51) **Cl.Int./Int.Cl. G01J 3/10** (2006.01),
G01J 3/28 (2006.01), **G01J 3/36** (2006.01),
G01N 21/27 (2006.01)
 (72) **Inventeurs/Inventors:**
 VANNUFFELEN, STEPHANE, JP;
 KAMIYA, AKIRA, JP;
 MIYASHITA, MASAKI, JP;
 INDO, KENTARO, CA;
 CIGLENEC, REINHART, US;
 YAMATE, TSUTOMU, JP
 (73) **Propriétaire/Owner:**
 SCHLUMBERGER CANADA LIMITED, CA
 (74) **Agent:** SMART & BIGGAR

(54) **Titre : PROCEDURE ET APPAREIL POUR ANALYSE SPECTRALE ETALONNEE DE FOND DE TROU**
 (54) **Title: METHOD AND APPARATUS FOR CALIBRATED DOWNHOLE SPECTRAL ANALYSIS OF FLUIDS**



(57) **Abrégé/Abstract:**

A fluid analysis system for use downhole comprises an input light signal that is directed through a fluid sample housed in a sample cell (184). The input light signal may originate from a plurality of light sources (180). An output light signal from the sample cell is then routed to one or more spectrometers (186) for measurement of the represented wavelengths in the output light signal. The output of the spectrometers is then compared to known values for hydrocarbons typically encountered downhole. This provides insight into the composition of the sample fluid. Additionally, the light from the light sources can be routed directly to the one or more spectrometers to be used in calibration of the system in the high temperature and noise environment downhole.



(12) INTERNATIONAL APPLICATION PUBLISHED UNDER THE PATENT COOPERATION TREATY (PCT)

(19) World Intellectual Property Organization
International Bureau(43) International Publication Date
2 August 2007 (02.08.2007)

PCT

(10) International Publication Number
WO 2007/085935 A1

(51) International Patent Classification:

G01J 3/10 (2006.01) *G01J 3/36* (2006.01)
G01J 3/28 (2006.01) *G01N 21/27* (2006.01)

(21) International Application Number:

PCT/IB2007/000153

(22) International Filing Date: 24 January 2007 (24.01.2007)

(25) Filing Language: English

(26) Publication Language: English

(30) Priority Data:

11/307,171 26 January 2006 (26.01.2006) US

(71) Applicant (for AL, AU, AZ, BG, CO, CZ, DE, DK, GR, HU, ID, IE, IL, IT, KR, KZ, LT, MX, NO, NZ, OM, PL, RO, RU, SI, SK, TM, TN, TR, TT, UA, UZ, ZA only): **SCHLUMBERGER TECHNOLOGY B.V.** [NL/NL]; Parkstraat 83-89, NL-2514 JG The Hague (NL).

(71) Applicant (for FR only): **SERVICES PETROLIERS SCHLUMBERGER** [FR/FR]; 42, rue Saint-Dominique, F-75007 Paris (FR).

(71) Applicant (for all designated States except AL, AU, AZ, BG, CA, CO, CZ, DE, DK, FR, GB, GR, HU, ID, IE, IL, IT, JP, KR, KZ, LT, MX, NL, NO, NZ, OM, PL, RO, RU, SI, SK, TM, TN, TR, TT, UA, US, UZ, ZA): **PRAD RESEARCH AND DEVELOPMENT N.V.** [NL/NL]; De Ruyterkade 62, Willemstad, Curacao (AN).

(71) Applicant (for CA only): **SCHLUMBERGER CANADA LIMITED** [CA/CA]; 525-3rd Ave S.W., Calgary, Alberta T2P 0G4 (CA).

(71) Applicant (for GB, JP, NL only): **SCHLUMBERGER HOLDINGS LIMITED**; P.O. Box 71, Craigmuir Chambers, Road Town, Tortola (VG).

(72) Inventors; and

(75) Inventors/Applicants (for US only): **VANNUFFELEN, Stephane** [FR/JP]; Kitazawa Duplex 305, 1-15-5, Kitazawa, Setagaya-ku, Tokyo 155-0031 (JP). **KAMIYA, Akira** [JP/JP]; 2603-1-107 Kamitsuruma, Sagamihara-shi, Kanagawa-ken 228-0802 (JP). **MIYASHITA, Masaki** [JP/JP]; 3-9-16, Nanyoudai, Hachioji-shi, Tokyo 192-0371 (JP). **INDO, Kentaro** [JP/CA]; #101 Macwan Rd. SW., Edmonton, Alberta 1W2 T6W (CA). **CIGLENEC, Reinhart** [AU/US]; 622 Frey Road, Katy, TX 77450 (US). **YAMATE, Tsutomu** [JP/JP]; 1-24-5-403, Kagahara, Tsuzuki-ku, Yokohama-shi, Kanagawa-ken 224-0055 (JP).

(74) Agent: **MATSUDA, Kiichiro**; Schlumberger K.K., 2-2-1 Fuchinobe, Sagamihara-shi, Kanagawa-ken 229-0006 (JP).

(81) Designated States (unless otherwise indicated, for every kind of national protection available): AE, AG, AL, AM, AT, AU, AZ, BA, BB, BG, BR, BW, BY, BZ, CA, CH, CN, CO, CR, CU, CZ, DE, DK, DM, DZ, EC, EE, EG, ES, FI, GB, GD, GE, GH, GM, GT, HN, HR, HU, ID, IL, IN, IS, JP, KE, KG, KM, KN, KP, KR, KZ, LA, LC, LK, LR, LS,

[Continued on next page]

(54) Title: METHOD AND APPARATUS FOR CALIBRATED DOWNHOLE SPECTRAL ANALYSIS OF FLUIDS

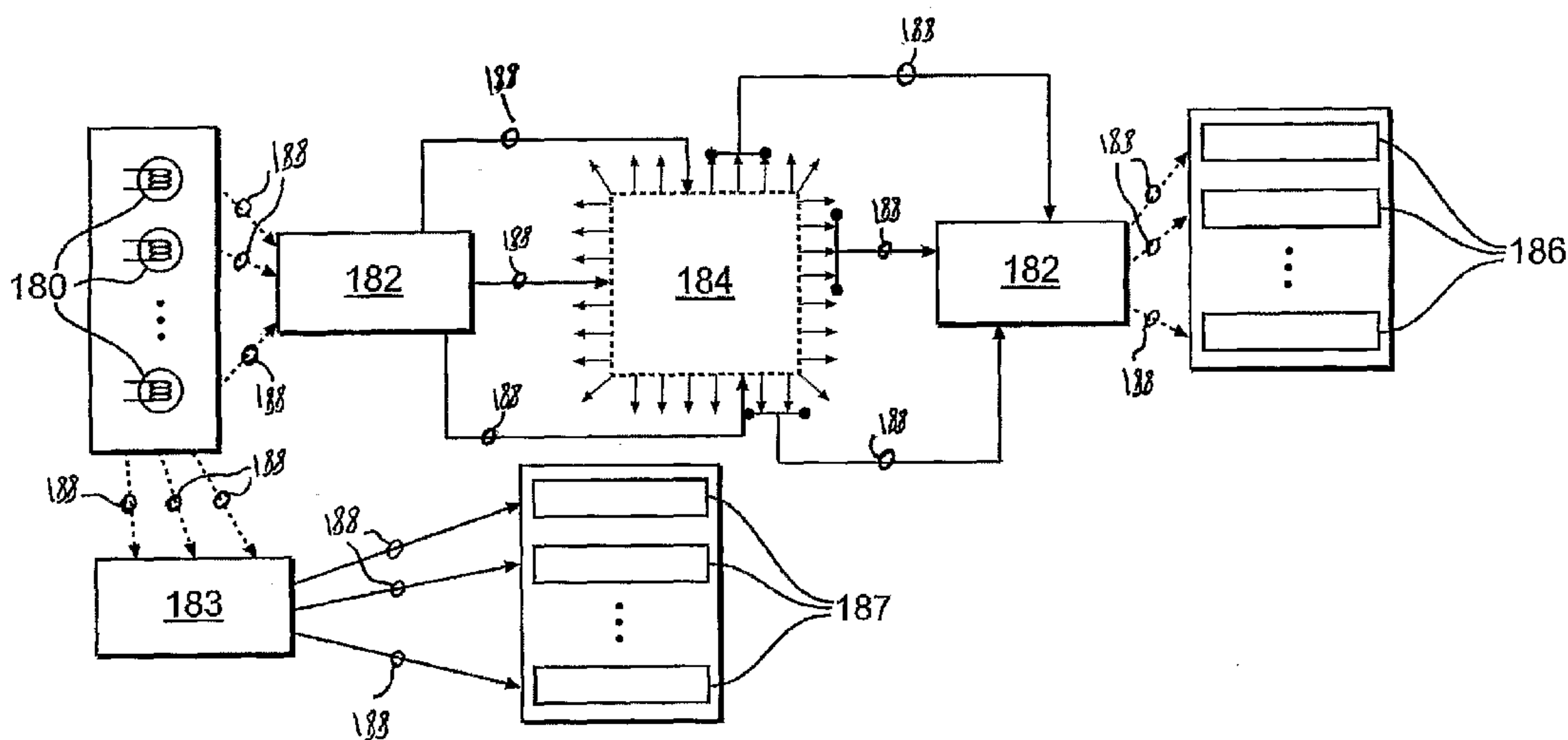

(57) Abstract: A fluid analysis system for use downhole comprises an input light signal that is directed through a fluid sample housed in a sample cell (184). The input light signal may originate from a plurality of light sources (180). An output light signal from the sample cell is then routed to one or more spectrometers (186) for measurement of the represented wavelengths in the output light signal. The output of the spectrometers is then compared to known values for hydrocarbons typically encountered downhole. This provides insight into the composition of the sample fluid. Additionally, the light from the light sources can be routed directly to the one or more spectrometers to be used in calibration of the system in the high temperature and noise environment downhole.

WO 2007/085935 A1

LT, LU, LV, LY, MA, MD, MG, MK, MN, MW, MX, MY, MZ, NA, NG, NI, NO, NZ, OM, PG, PH, PL, PT, RO, RS, RU, SC, SD, SE, SG, SK, SL, SM, SV, SY, TJ, TM, TN, TR, TT, TZ, UA, UG, US, UZ, VC, VN, ZA, ZM, ZW.

(84) Designated States (*unless otherwise indicated, for every kind of regional protection available*): ARIPO (BW, GH, GM, KE, LS, MW, MZ, NA, SD, SL, SZ, TZ, UG, ZM, ZW), Eurasian (AM, AZ, BY, KG, KZ, MD, RU, TJ, TM), European (AT, BE, BG, CH, CY, CZ, DE, DK, EE, ES, FI, FR, GB, GR, HU, IE, IS, IT, LT, LU, LV, MC, NL, PL, PT,

RO, SE, SI, SK, TR), OAPI (BF, BJ, CF, CG, CI, CM, GA, GN, GQ, GW, ML, MR, NE, SN, TD, TG).

Published:

- *with international search report*
- *before the expiration of the time limit for amending the claims and to be republished in the event of receipt of amendments*

For two-letter codes and other abbreviations, refer to the "Guidance Notes on Codes and Abbreviations" appearing at the beginning of each regular issue of the PCT Gazette.

77675-65

TITLE OF INVENTION

METHOD AND APPARATUS FOR CALIBRATED DOWNHOLE SPECTRAL ANALYSIS OF FLUIDS

FIELD OF THE INVENTION

The present invention relates to methods and apparatus for fluid analysis using a spectrometer architecture downhole in subterranean formation evaluation and testing for the purpose of exploration and development of hydrocarbon-producing wells, such as oil or gas wells. More specifically, a fluid analysis module with a first spectrometer is used in determining the composition of downhole fluids and a second spectrometer is used in calibration.

BACKGROUND OF THE INVENTION

In order to evaluate the nature of underground formations surrounding a borehole, it is often desirable to obtain and analyze samples of formation fluids from a plurality of specific locations in the borehole. Over the years, various tools and procedures have been developed to facilitate this formation fluid evaluation process. Examples of such tools can be found in U.S. Pat. No. 6,476,384 ("the '384 patent"), assigned to Schlumberger Technology Corporation ("Schlumberger").

Schlumberger's Repeat Formation Tester (RFT) and Modular Formation Dynamics Tester (MDT) tools are specific examples of sampling tools as described in the '384 patent. In particular, the MDT tool includes a fluid analysis module for analyzing fluids sampled by the tool.

Over the years, various fluid analysis modules have been developed for use in connection with sampling tools, such as the MDT tool, in order to identify and characterize the samples of formation fluids drawn by the sampling tool. For example, Schlumberger's U.S. Pat. No. 4,994,671 describes an exemplary fluid analysis module that includes a testing chamber, a light source, a spectral detector, a database, and a processor. Fluids drawn from the formation into the testing chamber by a fluid admitting assembly are analyzed by directing light at the fluids, detecting the spectrum of the transmitted and/or backscattered light, and processing the information (based on information in the database relating to different spectra) in order to characterize the formation fluids. Schlumberger's U.S. Pat. No. 5,167,149 and U.S. Pat. No. 5,201,220 also describe reflecting light from a window/fluid flow interface at certain specific angles to determine the presence of gas in the fluid flow. In addition, as described in U.S. Pat. No.

77675-65

5,331,156, by taking optical density (OD) measurements of the fluid stream at certain predetermined energies, oil and water fractions of a two-phase fluid stream may be quantified. As the techniques for measuring and characterizing formation fluids have become more advanced, the demand for more precise and expandable formation fluid analysis tools has increased.

Prior optical fluid analysis tools typically utilized a single light source directed at a sample cell and a single spectrometer to collect and analyze the light. In a typical embodiment, a filter array (FA) spectrometer is used which provides a maximum of about 20 channels. These tools are used downhole in adverse conditions which can affect the signal to noise ratio of the spectrometer. Also, size constraints downhole are often limiting so any tool used must fit into a very small space.

The prior approaches while being largely effective also exhibit certain limitations. While the measurements from the single FA spectrometer are useful, it is desirable to have a system where multiple spectrometers of different types can be utilized downhole at the same time to analyze fluid. This would alleviate the need for multiple separate modules; a single light source may provide information to a group of different spectrometers increasing the number of channels available and the specificity of the overall system.

Adverse conditions downhole also make it necessary to calibrate a spectrometer system such as those in the prior art. This requires directing at least two beams of light, one reference signal and one measurement signal, at a spectrometer. This requires differentiation of light signals which may be achieved through the use of a light chopper, as disclosed in co-pending U.S. Patent Publication No. 2007/0109537 relating to real-time calibration for a downhole spectrometer. However, light choppers require a motor that increases the size of the downhole tool significantly.

SUMMARY OF THE INVENTION

In consequence of the background discussed above, and other factors that are known in the field of downhole fluid analysis, applicants recognized a need for an apparatus and method for broad spectral optical analysis while providing detailed spectral analysis in a range of interest. In this, applicants recognized that in certain circumstances in downhole environments it would be desirable and/or necessary to separately situate two or more spectrometers that are independently configured for spectral measurements of fluids and for the calibration of the one or more measurement spectrometers.

77675-65

One aspect of the invention comprises a method and apparatus for fluid analysis downhole using one or more spectrometers. In one embodiment of the present invention, one or more light sources that provide input light are directed at a sample cell that contains fluid. Light output from the sample cell is measured by a first spectrometer for fluid analysis. Additionally, input light from the one or more light sources is routed directly to a second spectrometer to provide a reference measurement used in calibration. Two or more different types of spectrometers may be used, including, but not limited to, filter array and grating spectrometers. In one embodiment, the first and second spectrometer may comprise more than one spectrometer and are identical in number and types of spectrometers.

Another aspect of the invention comprises a fluid analysis system configured to operate downhole in a well traversing a formation, comprising a downhole tool including: at least one light source generating an input light; a sample cell operably connected to said at least one light source receiving a sample fluid therein, said sample cell further comprising: at least one input window allowing said input light to flow into said sample cell and through the sample fluid to produce an output light; at least one output window allowing said output light to flow out of said sample cell; at least a first spectrometer operably connected to the output of said sample cell and being configured to measure said output light and generate a plurality of measurement signals; an analysis device operably connected to outputs of said first spectrometer and being configured to receive said plurality of measurement signals and determine properties of the sample fluid; at least a second spectrometer operably connected to receive light directly from said at least one light source and being configured to measure said input light and generate a plurality of reference signals; a calibration device operably connected to outputs of said second spectrometer and being configured to receive said plurality of reference signals and calibrate said first spectrometer and other electronics.

A further aspect of the invention comprises a method for downhole fluid analysis in a downhole tool, comprising: providing input light using at least one light source; inserting a sample fluid into a sample cell; introducing said input light to an input window of said sample cell, said light traversing through said sample fluid and producing an output light traversing through an output window in said sample cell; receiving said output light at a first

77675-65

spectrometer; generating a plurality of measurement signals by said first spectrometer based on said output light; analyzing said plurality of measurement signals to determine properties of said sample fluid; receiving said input light at a second spectrometer directly from said at least one light source; generating a plurality of reference signals by said second spectrometer;
5 and calibrating said first spectrometer and other electronics using said plurality of reference signals.

Additional advantages and novel features of the invention will be set forth in the description which follows or may be learned by those skilled in the art through reading the materials herein or practicing the invention. The advantages of the invention may be achieved
10 through the means recited in the attached claims.

BRIEF DESCRIPTION OF THE DRAWINGS

The accompanying drawings illustrate preferred embodiments of the present invention and are a part of the specification. Together with the following description, the drawings demonstrate and explain principles of the present invention.

15 FIGURE 1 is a schematic view of one exemplary context in which the present invention may be used.

FIGURE 2 is a schematic partial cross-sectional view of one exemplary structure of a fluid analysis module according to the present invention.

20 FIGURE 3 is a cross-sectional schematic view of one filter channel in a larger filter array type spectrometer.

FIGURE 4 is an illustrative representation of the absorption spectra of a number of hydrocarbons encountered downhole.

25 FIGURE 5 is a schematic representation of one exemplary structure of a method and apparatus according to the present invention where light from multiple sources is routed to two sets of spectrometers;

77675-65

FIGURE 6 is a cross-sectional schematic of an exemplary sample cell in one downhole implementation of a spectral analysis system according to the present invention.

FIGURE 7 is a detailed schematic of one embodiment of the present invention showing two separate spectrometers for measurement and reference.

77675-65

Throughout the drawings, identical reference numbers indicate similar, but not necessarily identical elements. While the invention is susceptible to various modifications and alternative forms, specific embodiments have been shown by way of example in the drawings and will be described in detail herein. However, it should be understood that the invention is not intended to be limited to the particular forms disclosed. Rather, the invention is to cover all modifications, equivalents and alternatives falling within the scope of the invention as defined by the appended claims.

DETAILED DESCRIPTION

Illustrative embodiments and aspects of the invention are described below. In the interest of clarity, not all features of an actual implementation are described in the specification. It will of course be appreciated that in the development of any such actual embodiment, numerous implementation-specific decisions must be made to achieve the developers' specific goals, such as compliance with system-related and business-related constraints, that will vary from one implementation to another. Moreover, it will be appreciated that such development effort might be complex and time-consuming, but would nevertheless be a routine undertaking for those of ordinary skill in the art having benefit of the disclosure herein.

Figure 1 is a schematic diagram of an exemplary downhole tool 110 for testing earth formations and analyzing the composition of fluids from the formation. Downhole tool 110 is suspended in a borehole 112 from a cable 115 that is connected in a conventional fashion to a surface system 118. Surface system 118 incorporates appropriate electronics and processing systems for control of downhole tool 110 and analysis of signals received from the downhole tool.

Downhole tool 110 includes an elongated body 119, which encloses a downhole portion of a tool control system 116. Elongated body 119 also carries a selectively-extendible fluid admitting/withdrawal assembly 120 and a selectively-extendible anchoring member 121. Examples of the fluid admitting/withdrawal assembly are shown and described, for example, in U.S. Pat. No. 3,780,575, U.S. Pat. No. 3,859,851, and U.S. Pat. No. 4,860,581.

Fluid admitting/withdrawal assembly

120 and anchoring member 121 are respectively arranged on opposite sides of the elongated body 119. Fluid admitting/withdrawal assembly 120 is equipped for selectively sealing off or isolating portions of the wall of borehole 112, such that pressure or fluid communication with the adjacent earth formation can be selectively established. A fluid analysis module 125 is also included within elongated body 119 and formation fluid to be analyzed is channeled through the

analysis module. The sampled fluid may then be expelled through a port (not shown) back into borehole 112, or sent to one or more sample chambers 122, 123 for recovery at the surface. Control of fluid admitting/withdrawal assembly 120, fluid analysis module 125, and the flow path to sample chambers 122, 123 is maintained by electrical control systems 116, 118.

Figure 2 shows the overall structure of one embodiment of a spectral analysis module 134 that may be integrated into the tool 110. The formation fluid 132 is the sample of interest to the end user of the system. This fluid may contain any number of components including, but not limited to, gas, oil, and water. As mentioned above, it is highly desirable to know what fluids are present and in what relative quantities. To accomplish this, light source 130 is positioned to direct light toward one of the two optical windows 136. In one embodiment, this light may be a halogen lamp, a light emitting diode (LED), a laser, or any other light source that can be introduced downhole. These light sources produce light across a wide spectral range, approximately 500-2000 nm in wavelength. The light produced by light source 130 is transmitted through the first optical window 136, through the sample fluid 132 and emerges from the second optical window 136. This light is collected and transmitted using fiber optic bundles which allows for the specific direction and routing of the light signals. The light of particular interest is that which is reflected, transmitted and/or emitted, i.e., the output light, from the sample fluid. This output light signal is directed (again, usually using fiber optics) to a spectrometer section 138 of the spectral analysis module. In prior systems, the spectrometer section typically contained a single FA spectrometer with a maximum of 20 channels. The instant invention provides for a plurality of spectrometers to be included in the spectrometer section 138. This increases the number of available channels and also allows for a different type of spectrometer, such as a grating spectrometer, to be included in the detection and analysis of the output light signal. The output of the spectrometer section is used in determining the characteristics of the sample fluid 132. In addition, light from the light source is routed directly to at least one reference spectrometer. There, it is introduced to one or more reference spectrometers for calibration purposes.

Figure 3 is a schematic view of one of the channels of an FA spectrometer that is typically used in prior systems and may be used as one of the spectrometers in the instant invention. Light is input at 140 via a fiber optic bundle which allows the light to be routed to each of the channels of the FA spectrometer through multiple paths labeled 142. One of those paths will deliver a light signal to input fiber bundle 144. This light then traverses through the first lens 146 and through filter 148. Filter 148 is typically a bandpass filter. This bandpass filter will only allow light in a range of wavelengths to pass. The full spectrometer has a

plurality of these filter elements, each of which may correspond to a different band of wavelengths. After moving through filter 148, the signal is refocused by the second lens 146 toward the output photodetector 150. This photodetector generates a current based on incident light with the current being proportional to the amount of incident light. This current is then converted to a voltage by I/V converter 152 and the voltage signal moves on for further processing. As can be seen, the voltage will differ for each tested wavelength and give an indication of the relative contributions of the different wavelengths. Based on control data, this will give insight to the composition of the sample fluid.

Optical absorption is wavelength dependent and is determined by the sample fluid composition. Figure 4 shows the absorption characteristics of several hydrocarbons and other fluids that will likely be encountered downhole. Axis 162 is the wavelength of light transmitted and axis 160 is the corresponding optical density (OD). Water is shown by line 164, element 166 corresponds to diesel, element 168 corresponds to condensate, element 170 corresponds to oil based mud filtrate, element 172 corresponds to crude A, and element 174 corresponds to crude B. Several spectral regions can be discriminated and these regions give insight into the composition of the overall fluid. It is shown here that water peaks at about 1450 nm, just before a region of high interest where a number of hydrocarbons peak. Between 1.6 μm and 1.8 μm , the region labeled 176, hydrocarbons have strong absorption and show many spectral dependent features that must be detected. However, due to the limited number of channels of the FA spectrometer, it is not possible to capture all the spectral details. The FA spectrometer covers from visible to IR range, this invention allows for a hybrid spectrometer architecture to add greater channel density in specific spectral regions.

Turning now to Figure 5, in the instant invention, two or more spectrometers are introduced downhole. In one embodiment, one of the spectrometers may be an FA spectrometer and one may be a grating spectrometer. The grating spectrometer may be used to provide very high channel density in a limited range of wavelengths. It is useful in measuring spectral details in the important 1.6-1.8 μm range labeled 176. For example, the grating spectrometer may be configured to provide approximately 16 channels; these channels are in addition to the 10-20 channels provided by the FA spectrometer and provide more specific information about a smaller spectral range. For example, the FA spectrometer may be configured to measure in the visible and infrared spectrum to determine the presence of fluids, such as water which has a peak at 1450 nm, and for baseline corrections, while the grating spectrometer may be configured to monitor the hydrocarbon range mentioned above. Other combinations of spectrometers are contemplated by the present invention such that a wide range of wavelengths are available for

spectral analysis of downhole fluids. Spectral features in the visible range are limited, so the high channel density of the grating spectrometer is not as much of a necessity.

A schematic of one embodiment of the invention is shown in Figure 5. Input light is provided by light source 180. As shown, there may be a plurality of different types of light produced at the light source. These include, but are not limited to, a halogen bulb (broad band light source), a light emitting diode (LED), and a laser. This input light may be processed by one of the light processing units 188. These light processing units may include any unit for changing a property of light, such as polarizer, amplitude and frequency modulators, among other light processing units. In one embodiment, the light then may be introduced to light collector 182 although this element is optional depending on the number of light sources and spectrometers in operation. This light collector is configured to allow light of different wavelengths to be routed to different locations or at different times. This is useful when it is desired to determine the affects of different light types independently. The input light then proceeds to one or more input windows of sample cell 184. This sample cell houses fluid flowing through the flowline which is the sample fluid to be tested. The light flows through the fluid and through interaction with the fluid undergoes change depending on the wavelength of the light and the composition of the fluid to produce an output light. For example, the input light may undergo reflection and/or absorption and/or light may be emitted as a result of interaction between the input light and the sample in the flowline. In this, the present invention contemplates a variety of known methodology for spectral analysis of fluids.

This output light traverses through an output window of the sample cell 184 and on to an optional light collector and router 182. The light is then routed to at least one measurement spectrometer 186. In this, more than one measurement spectrometer 186 may be provided as schematically depicted in Figure 5. As mentioned above, in one embodiment of the present invention, at least one of a plurality of measurement spectrometers 186 may be an FA spectrometer and at least another one of the plurality may be a grating spectrometer. The output of these spectrometers, as mentioned above, will show the amount of light in a set of wavelength ranges.

In addition to the light incident on the sample cell, it is also advantageous to route light directly from the one or more light sources 180 to at least one reference spectrometer 187. However, as schematically depicted in Figure 5, a plurality of reference spectrometers 187 may be provided. The light sources, photodetectors, and processing electronics employed in conventional fluid analysis modules are typically adversely affected by the extreme temperatures and vibrations experienced downhole. For example, the optical power of light sources tends to

77675-65

diminish or drift when operated at elevated temperatures. Similarly, the optical gains of many photodetectors may drift by significant amounts when subjected to these high operating temperatures. These shifts may result in improper results, but calibration can be accomplished while testing, i.e., in real time, to compensate for this drift. This calibration is accomplished by continuously directing light from the light sources 180 to the one or more reference spectrometers 187. To accomplish this, light from the one or more light sources 180 is routed, via a fiber optic bundle, through optional light collector 183 and then on to one or more reference spectrometers 187. This light signal is referred to as the reference light signal, the light directed through sample cell 184 is referred to as the measurement light signal. The one or more second spectrometers 187 are called reference spectrometers. In one aspect of the present invention, they are identical in number and type to the one or more first spectrometers 186, which are called measurement spectrometers. This allows for each spectrometer to be calibrated based on the conditions and response downhole.

The reference signal is then used in calibration while the measurement signal is used to determine the composition of the fluid in the sample cell 184.

U.S. Patent Publication No. US2007/0109537 discloses real-time calibration for a downhole spectrometer.

Figure 6 is a cross sectional view of one example of a sample cell described in the previous figures. The depicted embodiment of the invention may be implemented in a plurality of other configurations. The sample fluid flows through flow channel 234. Opposed openings 236 and 240 are provided in the flowline each of which interfaces with an input or an output window and flange assemblies, respectively. Structurally, the input and output sides of the cell are identical, so only the input side will be described in detail. Flow channel 234 is located between openings 236 and 240 and defines window locating seats. Windows 242 are located on each side of the flow channel 234. In one embodiment, the windows may be made of sapphire. The windows 242 are secured in place by flanges 230 which are provided with optical connectors to connect the outer faces of the windows 242 with fiber bundles 232 and 244. The flanges may be screwed to each other so as to seal the windows into the seats. Sealing is assisted by the use of back up rings and o-rings 238. Inner and outer faces of the windows 242 are polished to optical quality, side faces are polished to assist in sealing.

This is just one sample cell with a single set of windows. There may be additional windows and fiber bundles that direct different types of light to different locations all traversing through the sample fluid. The light input through fiber bundle 232 interacts with the sample

fluid and the output light is collected by fiber bundle 244. This received light signal is then forwarded on to the one or more measurement spectrometers for analysis.

Figure 7 is a schematic representation of one embodiment of a spectral analysis system according to the present invention. Chassis 264 houses the majority of the device that is introduced downhole in either a wireline or logging-while-drilling (LWD) or measurement-while-drilling (MWD) or production logging or permanent monitoring of a well type tools. Moreover, the present invention contemplates applicability in areas such as carbon-di-oxide sequestration and water reservoir management. In this, it is contemplated that the systems and methods disclosed herein will have wide ranging applications in a variety of downhole fluid analysis operations that employ conventional spectral analysis systems for downhole applications.

Flowline 266 is filled with sample fluid via the intake shown in Figure 1. Light source 250 introduces light to the system. This source may be a halogen lamp, an LED, a laser, or any other suitable source. Although only one light source is shown, there may be multiple light sources of a variety of types to produce light across a wide spectrum. The input light is split into two channels. Channel 252 is the reference channel and the light signal there is the light as output from the light source 250. This light is then introduced to spectrometer 254. An FA spectrometer is illustrated, but this could be any type of spectrometer and would include two or more different spectrometers. These spectrometers measure the known input light and calibrate the output of the measurement spectrometers accordingly. The output of the reference spectrometer is monitored by the electronics 262. Channel 258 is the measurement channel. This channel routes light through the input window of the sample cell 256. The light traverses through the sample and interacts with the sample fluid. The output light is directed to the measurement spectrometer 260. Again, two or more spectrometers may be used here and the outputs of the spectrometers are monitored by monitoring electronics 262. Although only an FA spectrometer is depicted, this could be any type of suitable spectrometer and, in one embodiment of the present invention, there may be at least one FA spectrometer and at least one grating spectrometer.

The output of the one or more measurement spectrometers is then used in analysis of the fluid sample. The electrical outputs of the spectrometers are proportional to the light of a given wavelength range that is incident on the spectrometers. This invention provides a large number of channels covering a wide range of wavelengths all of which can be accomplished downhole.

In the systems and methods disclosed herein, one or more light sources 180 are directed at a sample cell 184. This light interacts with sample fluid, is collected in fiber bundles and

routed to one or more measurement spectrometers 186. For example, a filter array spectrometer may be configured to provide information over a wide spectral range, a grating spectrometer may be configured to provide finer analysis of a smaller range of wavelengths that are of special interest in determining the presence of desired hydrocarbons.

In addition to one function of measurements of output light from a sample fluid, light may also be routed directly from the light sources to one or more reference spectrometers, for example, identical to the measurement spectrometers in number and type. This reference signal is used in calibration of the spectrometers and associated electronics as their performance may change in the high temperature and noise environment downhole. This architecture reduces the overall size of the system when compared with other attempts to provide the same information.

The preceding description has been presented only to illustrate and describe the invention and some examples of its implementation. It is not intended to be exhaustive or to limit the invention to any precise form disclosed. Many modifications and variations are possible in light of the above teaching.

The preferred aspects were chosen and described in order to best explain principles of the invention and its practical applications. The preceding description is intended to enable others skilled in the art to best utilize the invention in various embodiments and aspects and with various modifications as are suited to the particular use contemplated. It is intended that the scope of the invention be defined by the following claims.

77675-65

CLAIMS:

1. A fluid analysis system configured to operate downhole in a well traversing a formation, comprising a downhole tool including:
- at least one light source generating an input light;
- 5 a sample cell operably connected to said at least one light source receiving a sample fluid therein, said sample cell further comprising:
- at least one input window allowing said input light to flow into said sample cell and through the sample fluid to produce an output light;
- at least one output window allowing said output light to flow out of said
- 10 sample cell;
- at least a first spectrometer operably connected to the output of said sample cell and being configured to measure said output light and generate a plurality of measurement signals;
- an analysis device operably connected to outputs of said first spectrometer and
- 15 being configured to receive said plurality of measurement signals and determine properties of the sample fluid;
- at least a second spectrometer operably connected to receive light directly from said at least one light source and being configured to measure said input light and generate a plurality of reference signals;
- 20 a calibration device operably connected to outputs of said second spectrometer and being configured to receive said plurality of reference signals and calibrate said first spectrometer and other electronics.
2. The fluid analysis system configured to operate downhole as defined in claim 1, wherein

77675-65

said first spectrometer comprises a first set of two or more spectrometers and said second spectrometer comprises a second set of two or more spectrometers, said second set of spectrometers being identical in number and type of spectrometers to said first set of spectrometers.

5 3. The fluid analysis system configured to operate downhole as defined in claim 1 further comprising:

a plurality of light sources wherein said plurality of light sources generate light across a wide spectral range.

4. The fluid analysis system configured to operate downhole as defined in claim 1
10 further comprising at least one of:

a first light collector positioned between said at least one light source and said sample cell;

a second light collector positioned between said sample cell and said first spectrometer; and

15 a third light collector positioned between said at least one light source and said second spectrometer.

5. The fluid analysis system configured to operate downhole as defined in claim 4, wherein

20 said first, second, and third light collectors further comprise a router configured to selectively route light to at least one of a specific input window, a specific spectrometer, and at a specific time.

6. The fluid analysis system configured to operate downhole as defined in claim 1, wherein

said first spectrometer comprises a filter array spectrometer.

77675-65

7. The fluid analysis system configured to operate downhole as defined in claim 1, wherein

said first spectrometer comprises a grating spectrometer.

8. The fluid analysis system configured to operate downhole as defined in claim 1, wherein

said first spectrometer comprises at least one filter array spectrometer and at least one grating spectrometer.

9. The fluid analysis system configured to operate downhole as defined in claim 1, wherein

10 said second spectrometer comprises one or more spectrometers and is identical to said first spectrometer in number and type of spectrometers.

10. The fluid analysis system configured to operate downhole as defined in claim 1, wherein

said at least one light source comprises a halogen lamp.

15 11. The fluid analysis system configured to operate downhole as defined in claim 1, wherein

said at least one light source comprises a light emitting diode (LED).

12. The fluid analysis system configured to operate downhole as defined in claim 1, wherein

20 said at least one light source comprises a laser.

13. A method for downhole fluid analysis in a downhole tool, comprising:

providing input light using at least one light source;

77675-65

inserting a sample fluid into a sample cell;

introducing said input light to an input window of said sample cell, said light traversing through said sample fluid and producing an output light traversing through an output window in said sample cell;

5 receiving said output light at a first spectrometer;

generating a plurality of measurement signals by said first spectrometer based on said output light;

analyzing said plurality of measurement signals to determine properties of said sample fluid;

10 receiving said input light at a second spectrometer directly from said at least one light source;

generating a plurality of reference signals by said second spectrometer; and

calibrating said first spectrometer and other electronics using said plurality of reference signals.

15 14. The method for downhole fluid analysis as defined in claim 13 further comprising:

providing input light from a plurality of light sources to a plurality of measurement spectrometers and a plurality of reference spectrometers, wherein said plurality of light sources generate light across a wide spectral range.

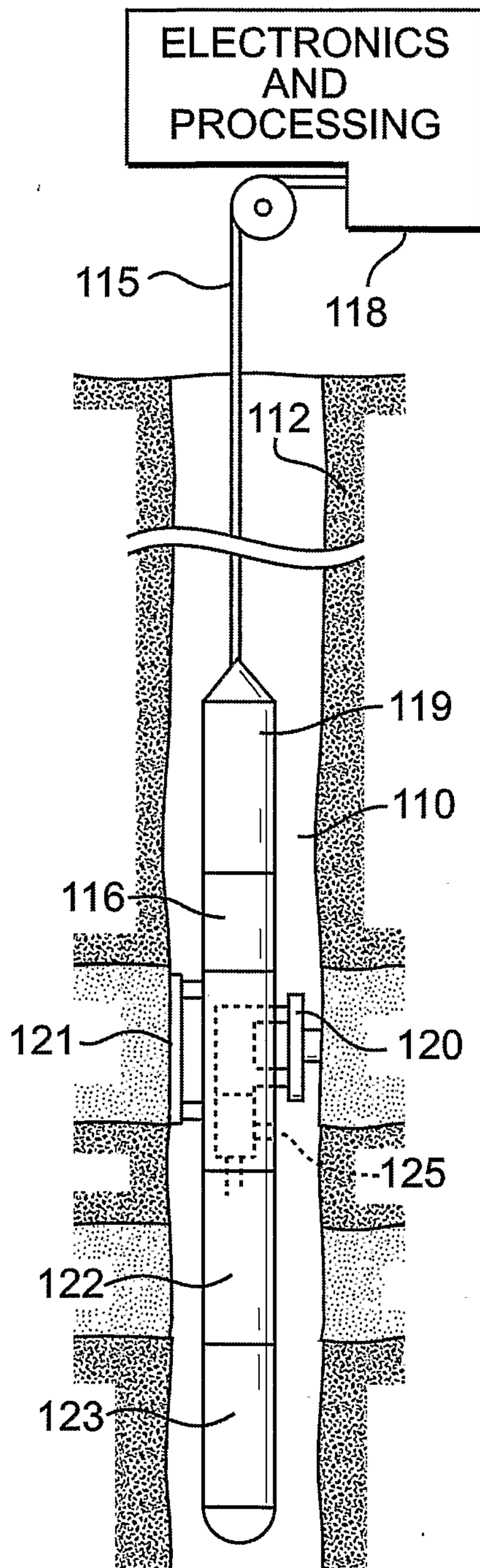

FIG. 1

2/6

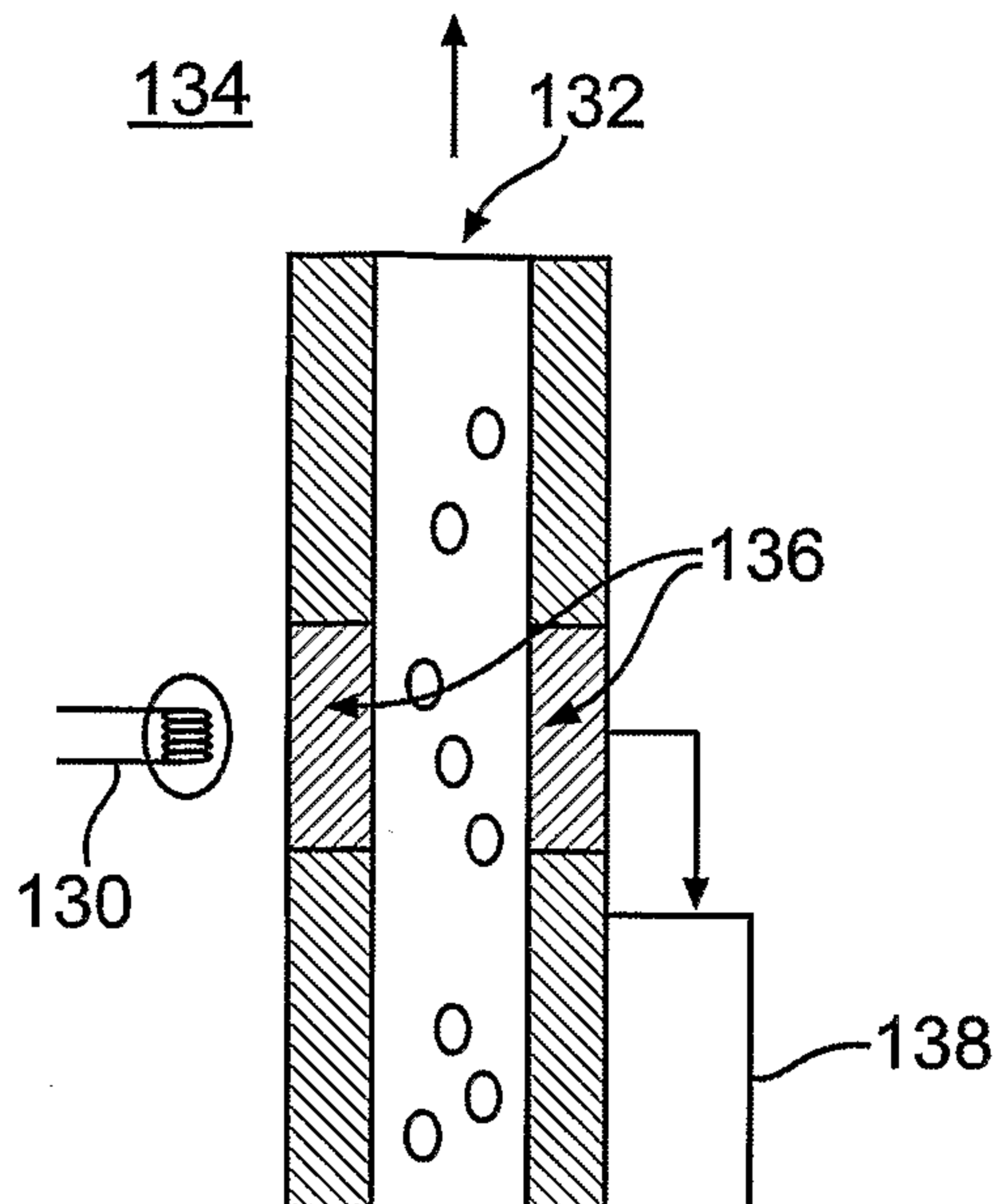

FIG. 2

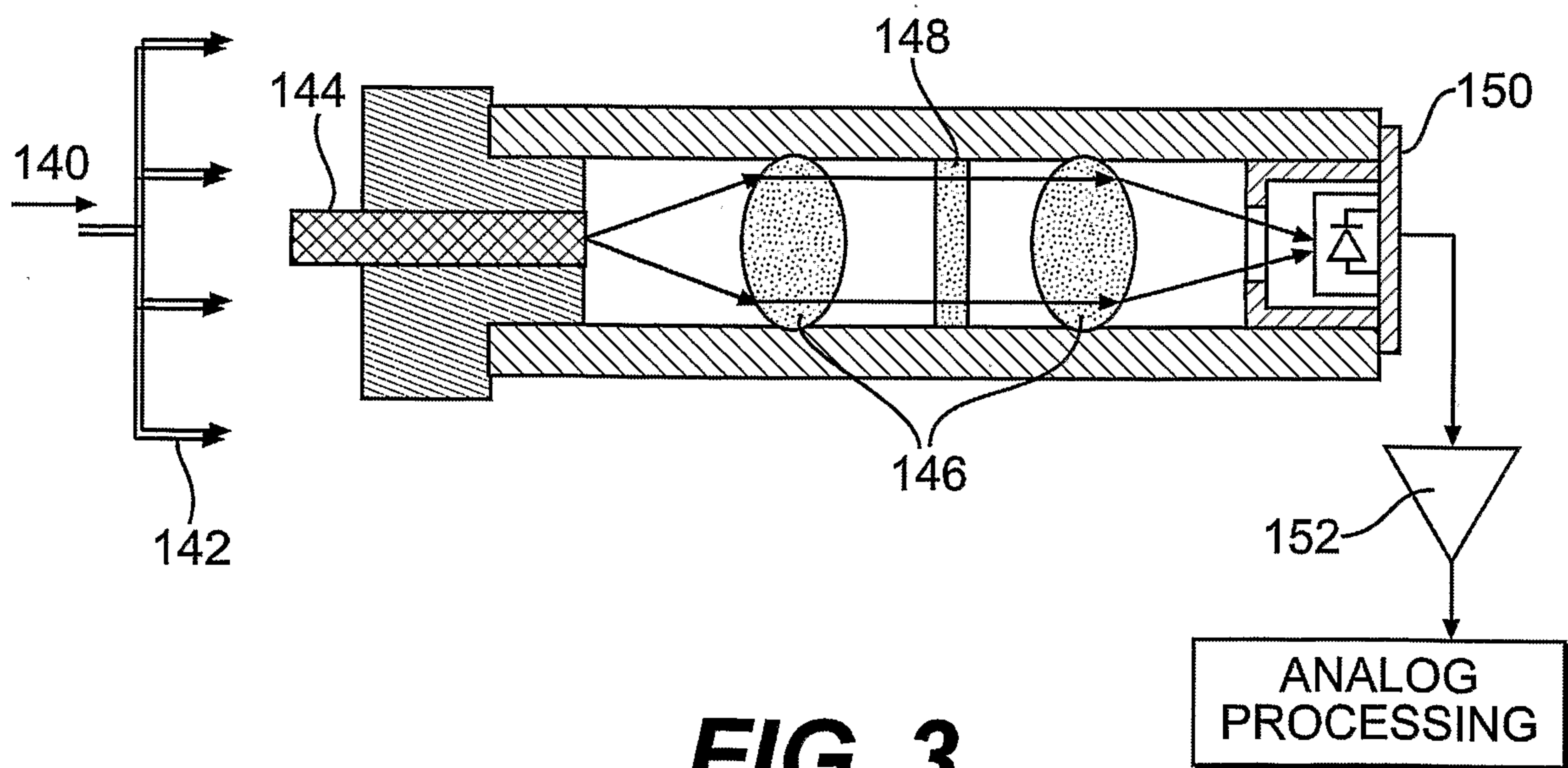

FIG. 3

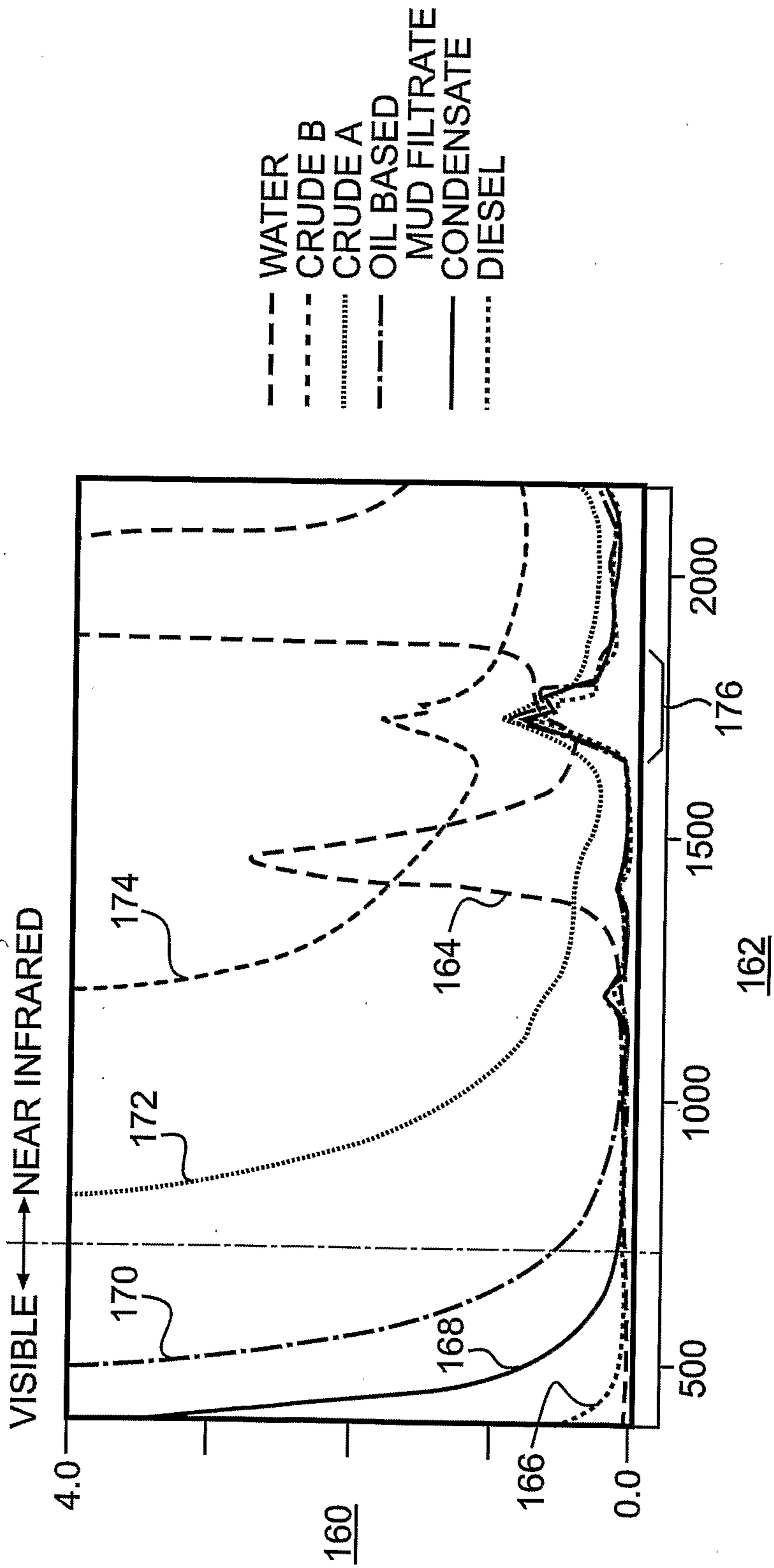

FIG. 4

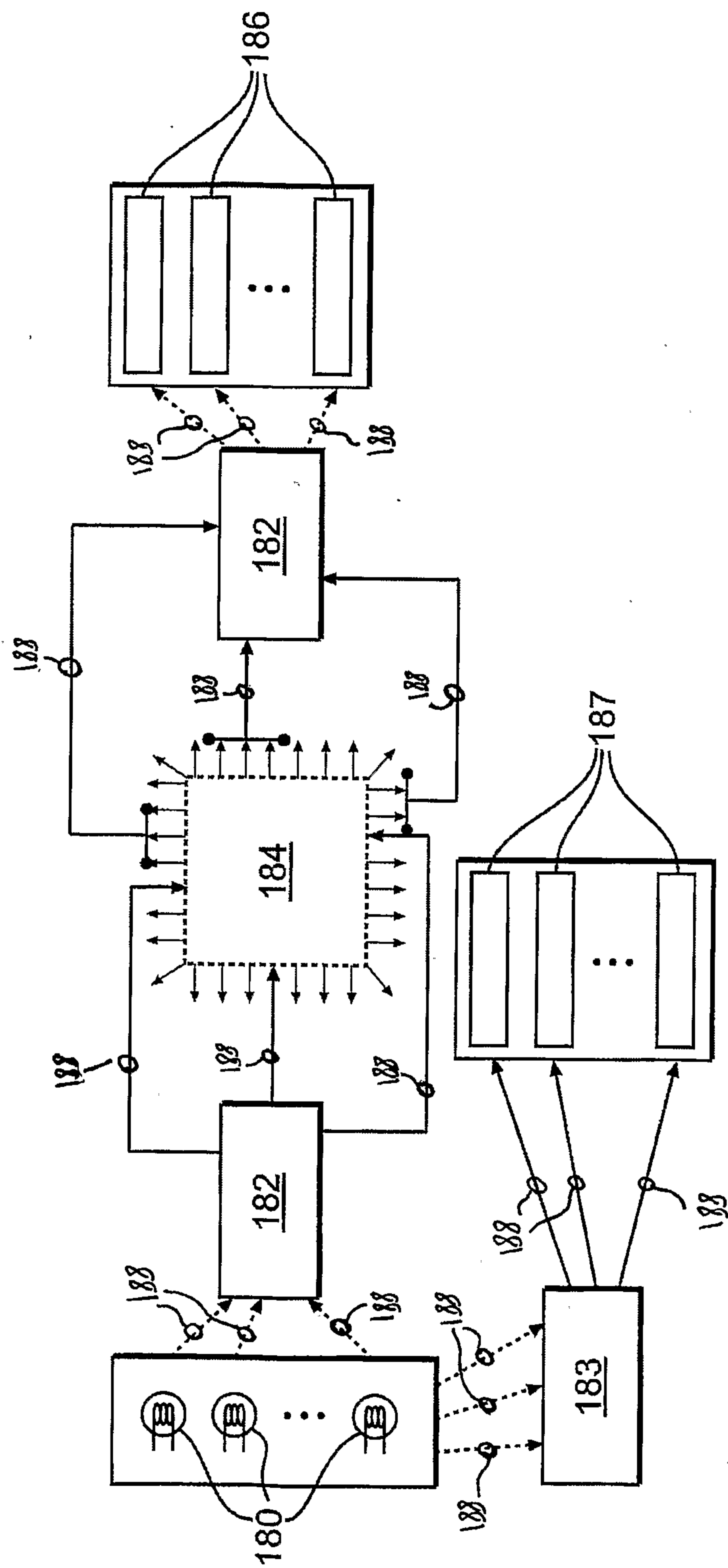

FIG. 5

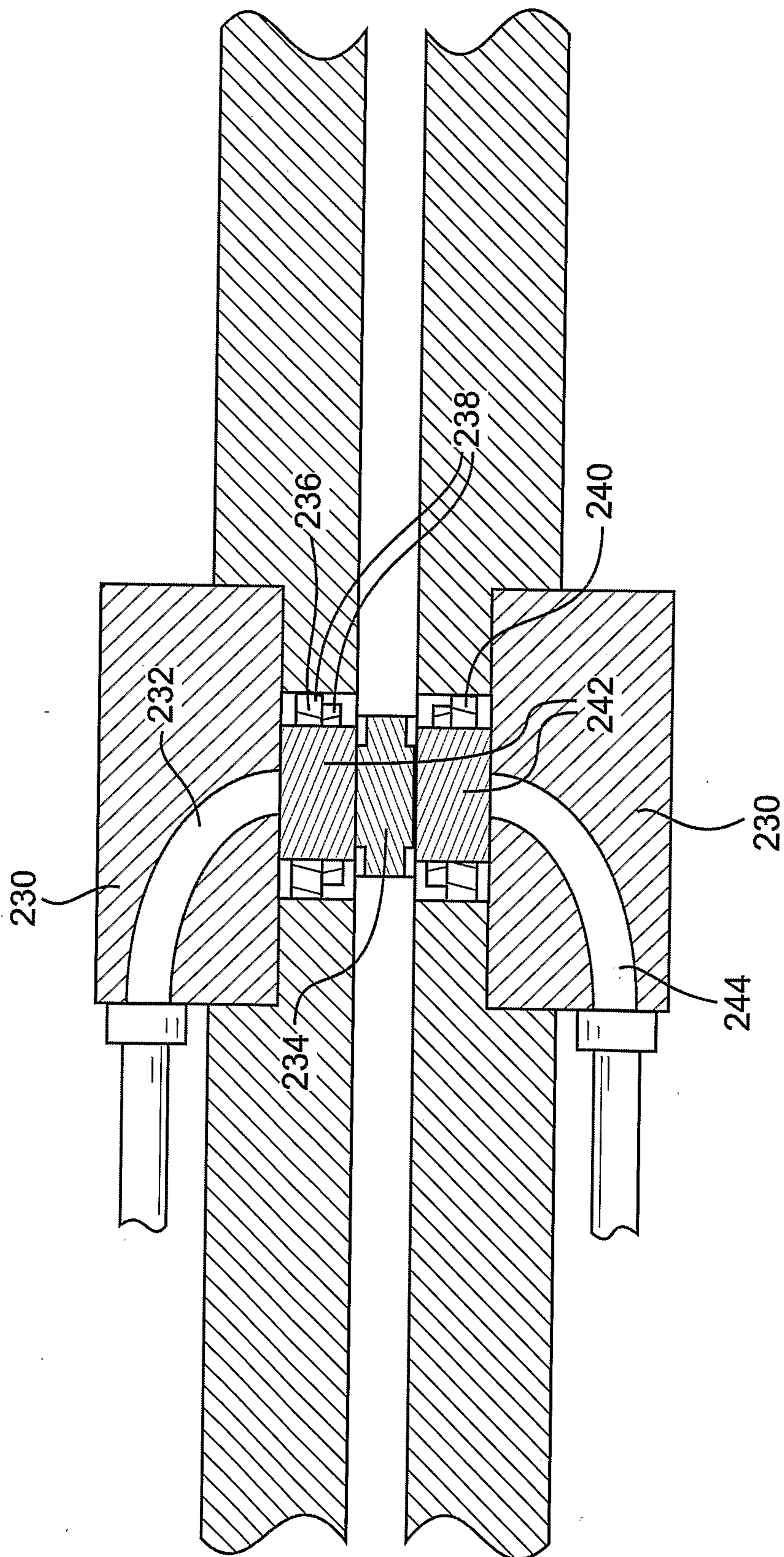

FIG. 6

6/6

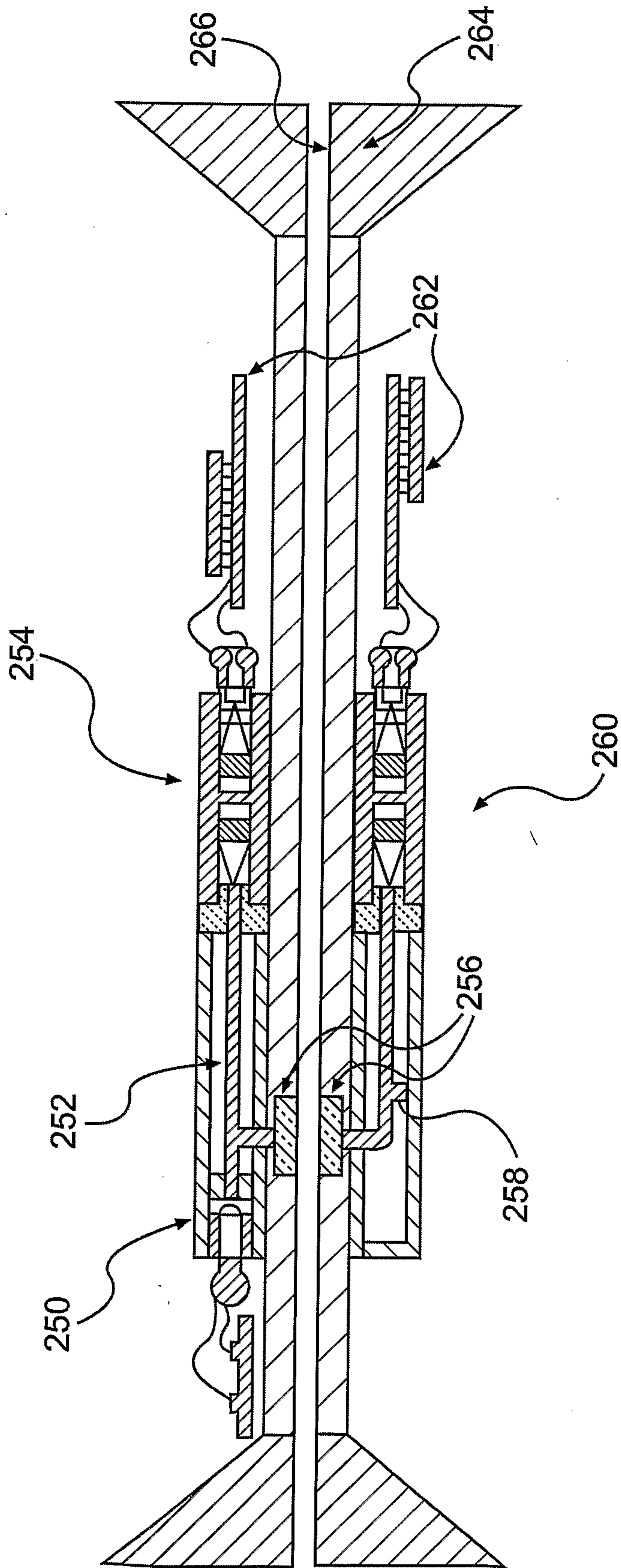

FIG. 7

