

(19) World Intellectual Property Organization  
International Bureau



(43) International Publication Date  
19 July 2007 (19.07.2007)

PCT

(10) International Publication Number  
**WO 2007/081102 A1**

- (51) International Patent Classification:  
*H04N 7/015* (2006.01)
- (21) International Application Number:  
PCT/KR2006/005814
- (22) International Filing Date:  
28 December 2006 (28.12.2006)
- (25) Filing Language: Korean
- (26) Publication Language: English
- (30) Priority Data:  
10-2006-0002703 10 January 2006 (10.01.2006) KR  
10-2006-0089736 15 September 2006 (15.09.2006) KR
- (71) Applicant (for all designated States except US): **LG ELECTRONICS INC.** [KR/KR]; 20, Yoido-Dong, Youngdungpo-gu, Seoul 150-010 (KR).
- (72) Inventors; and
- (75) Inventors/Applicants (for US only): **KIM, Jong Moon** [KR/KR]; 1211-1106, Cheolsan Jugong 12-Danji Apt., Cheolsan 3-dong, Gwangmyeong-si, Gyeonggi-do 423-736 (KR). **CHOI, In Hwan** [KR/KR]; 107-207,

Jugong 1-danji Apt., 37, Jungang-dong, Gwacheon-si, Gyeonggi-do 427-740 (KR).

(74) Agents: **KIM, Yong In** et al.; 15th Floor, Yeosam Bldg., 648-23, Yeoksam-dong, Kangnam-gu, Seoul 135-080 (KR).

(81) Designated States (unless otherwise indicated, for every kind of national protection available): AE, AG, AL, AM, AT, AU, AZ, BA, BB, BG, BR, BW, BY, BZ, CA, CH, CN, CO, CR, CU, CZ, DE, DK, DM, DZ, EC, EE, EG, ES, FI, GB, GD, GE, GH, GM, GT, HN, HR, HU, ID, IL, IN, IS, JP, KE, KG, KM, KN, KP, KZ, LA, LC, LK, LR, LS, LT, LU, LV, LY, MA, MD, MG, MK, MN, MW, MX, MY, MZ, NA, NG, NI, NO, NZ, OM, PG, PH, PL, PT, RO, RS, RU, SC, SD, SE, SG, SK, SL, SM, SV, SY, TJ, TM, TN, TR, TT, TZ, UA, UG, US, UZ, VC, VN, ZA, ZM, ZW.

(84) Designated States (unless otherwise indicated, for every kind of regional protection available): ARIPO (BW, GH, GM, KE, LS, MW, MZ, NA, SD, SL, SZ, TZ, UG, ZM, ZW), Eurasian (AM, AZ, BY, KG, KZ, MD, RU, TJ, TM), European (AT, BE, BG, CH, CY, CZ, DE, DK, EE, ES, FI, FR, GB, GR, HU, IE, IS, IT, LT, LU, LV, MC, NL, PL, PT, RO, SE, SI, SK, TR), OAPI (BF, BJ, CF, CG, CI, CM, GA, GN, GQ, GW, ML, MR, NE, SN, TD, TG).

[Continued on next page]

(54) Title: DIGITAL BROADCASTING SYSTEM AND METHOD OF PROCESSING DATA

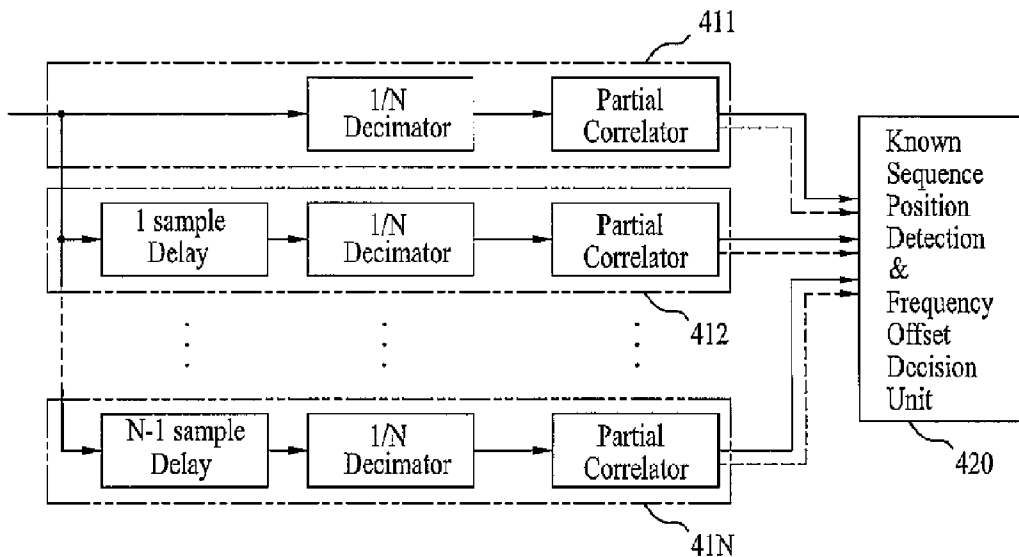

(57) Abstract: The present invention relates to a digital broadcasting system. More particularly, the present invention inserts and outputs pre-defined known data, which are already known by a transmitting system and a receiving system, in a specific place within a data area to which enhanced data are transmitted, and wherein the receiving system detects the known data for a demodulating or equalizing process, such as frequency synchronization, thereby enhancing a receiving performance in an environment with frequent channel changes and vulnerable to noise.

WO 2007/081102 A1



**Published:**

— with international search report

*For two-letter codes and other abbreviations, refer to the "Guidance Notes on Codes and Abbreviations" appearing at the beginning of each regular issue of the PCT Gazette.*

# Description

## DIGITAL BROADCASTING SYSTEM AND METHOD OF PROCESSING DATA

### Technical Field

- [1] The present invention relates to a digital telecommunication system, and more particularly, to an apparatus and a method that are used for transmitting and receiving digital broadcast programs.

### Background Art

- [2] Presently, the technology for processing digital signals is being developed at a vast rate, and, as a larger number of the population uses the Internet, digital electric appliances, computers, and the Internet are being integrated. Therefore, in order to meet with the various requirements of the users, a system that can transmit diverse supplemental information in addition to video/audio data through a digital television channel needs to be developed.
- [3] Some users may assume that supplemental data broadcasting would be applied by using a PC card or a portable device having a simple in-door antenna attached thereto. However, when used indoors, the intensity of the signals may decrease due to a blockage caused by the walls or disturbance caused by approaching or proximate mobile objects. Accordingly, the quality of the received digital signals may be deteriorated due to a ghost effect and noise caused by reflected waves. However, unlike the general video/audio data, when transmitting the supplemental data, the data that is to be transmitted should have a low error ratio. More specifically, in case of the video/audio data, errors that are not perceived or acknowledged through the eyes or ears of the user can be ignored, since they do not cause any or much trouble. Conversely, in case of the supplemental data (*e.g.*, program execution file, stock information, etc.), an error even in a single bit may cause a serious problem. Therefore, a system highly resistant to ghost effects and noise is required to be developed.
- [4] The supplemental data are generally transmitted by a time-division method through the same channel as the video/audio data. However, with the advent of digital broadcasting, digital television receivers that receive only video/audio data are already supplied to the market. Therefore, the supplemental data that are transmitted through the same channel as the video/audio data should not influence the conventional receivers that are provided in the market. In other words, this may be defined as the compatibility of broadcast system, and the supplemental data broadcast system should be compatible with the broadcast system. Herein, the supplemental data may also be referred to as enhanced data. Furthermore, in a poor channel environment, the

receiving performance of the conventional receiver may be deteriorated. More specifically, resistance to changes in channels and noise is more highly required when using portable and/or mobile receivers.

## **Disclosure of Invention**

### **Technical Problem**

- [5] Accordingly, the present invention is to provide a digital broadcasting system that is suitable for transmitting supplemental data and that is highly resistant to noise.
- [6] The present invention is to provide a broadcasting system and a method of processing data that can periodically insert known data in a specific domain of the supplemental data and transmitting the data to a broadcast receiving system, thereby enhancing the receiving performance of the broadcast receiving system.
- [7] The present invention is to provide a system for a receiving system and a method of processing data that can detect the transmitted known data, which is used for frequency synchronization, thereby enhancing the receiving performance.

### **Technical Solution**

- [8] To achieve these objects and other advantages and in accordance with the purpose of the invention, as embodied and broadly described herein, a receiving system includes a demodulator, a known data detector and coarse frequency offset detector, and a channel equalizer. The demodulator tunes and receives known data, when the known data having a specific pattern are periodically inserted in valid data, estimates a frequency offset from a signal received based upon known data information, and compensates the estimated offset frequency. The known data detector and coarse frequency offset detector detects known data information inserted by a transmitting system and a coarse frequency offset from the signal prior to or after being demodulated. The channel equalizer uses the known data information detected from the known data detector and coarse frequency offset detector so as to compensate a channel distortion included in output data of the demodulator.
- [9] The demodulator includes a multiplier, a fine frequency offset estimator, a select unit, and a compensation signal output unit. The multiplier multiplies an input signal with a complex signal so as to compensate the frequency offset. The fine frequency offset estimator estimates a fine frequency offset from an output of the multiplier based upon the known data information outputted from the known data detector and coarse frequency offset detector. The select unit initially selects a coarse frequency offset estimation value outputted from the known data detector and coarse frequency offset detector, and subsequently selects a fine frequency offset estimation value outputted from the fine frequency offset estimator. The compensation signal output unit generates a compensation frequency corresponding to the frequency offset being

outputted from the select unit, and outputs a complex signal corresponding to the generated compensation frequency to the multiplier.

[10] In another aspect of the present invention, a data processing method of a digital broadcast receiving system includes a step of tuning and receiving known data, when the known data having a specific pattern are periodically inserted in valid data, oversampling the received known data to N times, and outputting the oversampled known data; a step of receiving input signals that are oversampled to N times and decimating the input signals a rate of 1/N for each sampling phase, and performing partial correlation in each partial correlator, thereby detecting known data information and a coarse frequency offset; a step of detecting a fine frequency offset from the received signal based upon the known data information; and a step of initially using the coarse frequency offset estimation value, and subsequently using a fine frequency offset estimation value so as to compensate a frequency offset from the input signal.

[11] It is to be understood that both the foregoing general description and the following detailed description of the present invention are exemplary and explanatory and are intended to provide further explanation of the invention as claimed.

### **Advantageous Effects**

[12] The digital broadcasting system and the data processing method according to the present invention have the following advantages. More specifically, the digital broadcasting system and the data processing method according to the present invention are highly protected against (or resistant to) any error that may occur when transmitting supplemental data through a channel. And, the present invention is also highly compatible to the conventional VSB receiving system. Moreover, the present invention may also receive the supplemental data without any error even in channels having severe ghost effect and noise.

[13] Additionally, by regularly inserting known data in a specific place (or position) of the data domain, by detecting the known data, and by using the detected data in frequency synchronization and channel equalization processes, the receiving performance of the digital broadcast (or digital television) receiving system liable to a frequent change in channel may be enhanced. Furthermore, the present invention is even more effective when applied to mobile and portable receivers, which are also liable to a frequent change in channel and which require protection (or resistance) against intense noise.

### **Brief Description of the Drawings**

[14] FIG. 1 illustrates a block diagram of a digital broadcast (or television) transmitting system according to the present invention;

[15] FIG. 2 illustrates an example of a data structure having known data regularly (or pe-

riodically) inserted in valid data according to the present invention;

[16] FIG. 3 illustrates a block diagram showing the overall structure of a demodulating unit within a digital broadcast (or television) receiving system according to an embodiment of the present invention;

[17] FIG. 4 illustrates a block diagram shown the structure of a known sequence detector and coarse frequency offset detector shown in FIG. 3;

[18] FIG. 5 illustrates a block diagram showing the structure of a partial correlator shown in FIG. 4 according to an embodiment of the present invention;

[19] FIG. 6 illustrates a block diagram showing the structure of a frequency synchronizer within a demodulating unit shown in FIG. 3 according to an embodiment of the present invention;

[20] FIG. 7 illustrates a block diagram showing the structure of a fine frequency offset estimator shown in FIG. 6 according to an embodiment of the present invention;

[21] FIG. 8 illustrates a block diagram of a digital broadcast (or television or DTV) transmitting system according to another embodiment of the present invention;

[22] FIG. 9 illustrates a block diagram showing a general structure of a demodulating unit within a digital broadcast (or television or DTV) receiving system according to another embodiment of the present invention;

[23] FIG. 10 illustrates a block diagram showing the structure of a digital broadcast (or television or DTV) receiving system according to an embodiment of the present invention; and

[24] FIG. 11 illustrates a block diagram showing the structure of a digital broadcast (or television or DTV) receiving system according to another embodiment of the present invention.

### **Best Mode for Carrying Out the Invention**

[25] Reference will now be made in detail to the preferred embodiments of the present invention, examples of which are illustrated in the accompanying drawings. Wherever possible, the same reference numbers will be used throughout the drawings to refer to the same or like parts.

[26] In addition, although the terms used in the present invention are selected from generally known and used terms, some of the terms mentioned in the description of the present invention have been selected by the applicant at his or her discretion, the detailed meanings of which are described in relevant parts of the description herein. Furthermore, it is required that the present invention is understood, not simply by the actual terms used but by the meaning of each term lying within.

[27] In the present invention, the enhanced data may either consist of data including information such as program execution files, stock information, and so on, or consist of

video/audio data. Additionally, the known data refer to data already known based upon a pre-determined agreement between the transmitting system and the receiving system. Furthermore, the main data consist of data that can be received from the conventional receiving system, wherein the main data include video/audio data.

[28] The present invention relates to having a transmitting end (or system) regularly (or periodically) insert and transmit known data, and to having a receiving end (or system) detecting the known data regularly inserted and transmitted so as to be used in frequency synchronization. Thus, the receiving performance of a receiving system may be enhanced.

[29] FIG. 1 illustrates a block diagram of a digital broadcast (or television) transmitting system according to the present invention, which is used for regularly inserting and transmitting known data. Herein, the digital broadcast transmitting system shown in FIG. 1 is only an example given to simplify the understanding of the present invention. Any transmitting system capable of regularly inserting and transmitting known data sequences may be applied to the present invention. Therefore, the features of the present invention are not limited only to the example given in the description of the present invention.

[30] FIG. 1 illustrates a block diagram of a digital television transmitting system according to the present invention. The digital television transmitting system includes a pre-processor 101, a packet formatter 102, a packet multiplexer 103, a data randomizer 104, a scheduler 105, a Reed-Solomon (RS) encoder/non-systematic Reed-Solomon (RS) parity place holder inserter 106, a data interleaver 107, a byte-symbol converter 108, an symbol processor 109, a known data generator 110, a symbol-byte converter 111, a non-systematic RS encoder 112, a trellis encoder 113, a frame multiplexer 114, and a transmitting unit 120. In the embodiment of the present invention having the above-described structure, a main data packet is outputted to the packet multiplexer 103, and enhanced data are outputted to the pre-processor 101. The pre-processor 101 pre-processes the enhanced data, such as encoding additional error correction, interleaving, and byte expansion by inserting null data, and then outputs the pre-processed enhanced data to the packet formatter 102.

[31] Based upon the control of the scheduler 105, the packet formatter 102 multiplexes the pre-processed enhanced data and the known data place holder having the null data inserted therein, thereby configuring a group. The data within the group are then divided into 184-byte unit enhanced data packets, and a 4-byte MPEG header is added to the beginning of the enhanced data packet, thereby outputting a 188-byte enhanced data packet (*i.e.*, a MPEG compatibility packet). Herein, when the receiving system receives the known data, the packet formatter 102 decides the known data place holder according to the control of the scheduler 105 so that the known data sequences are

regularly inserted and received within a data frame.

- [32] The output of the packet formatter 102 is inputted to the packet multiplexer 103. The packet multiplexer 103 time-division multiplexes the main data packet and the enhanced data packet group in transport stream (TS) packet units and outputs the multiplexed TS packet in accordance with the control of the scheduler 105. More specifically, the scheduler 105 generates and outputs a control signal so that the packet formatter 102 can multiplex the enhanced data packet and the known data place holder. Accordingly, the packet multiplexer 103 receives the control signal, thereby multiplexing and outputting the main data packet and the enhanced data packet group to TS packet units.
- [33] The output data of the packet multiplexer 103 are inputted to the data randomizer 104. The data randomizer 104 discards (or deletes) the MPEG synchronization byte and randomizes the remaining 187 bytes by using a pseudo-random byte, which is generated from inside the data randomizer 104. Thereafter, the randomized data are outputted to the Reed-Solomon (RS) encoder/non-systematic RS parity place holder inserter 106. The RS encoder/non-systematic RS parity place holder inserter 106 processes the randomized data with a systematic RS-coding process, if the randomized data correspond to the main data packet. Conversely, the RS encoder/non-systematic RS parity place holder inserter 106 processes the randomized data with a non-systematic RS parity place holder insertion process, if the randomized data correspond to the enhanced data packet.
- [34] The output data of the RS encoder/parity place holder inserter 106 are provided to the data interleaver 107. Then, the data interleaver 107 interleaves and outputs the received data. At this point, the data interleaver 107 receives a RS parity byte that is newly calculated and outputted by the non-systematic RS encoder 112 and, then, outputs the newly received RS parity byte instead of the non-systematic RS parity place holder which is not yet outputted. Each byte outputted from the data interleaver 107 is converted into 4 symbols by the byte-symbol converter 108, which are then inputted to the symbol processor 109. Herein, one symbol consists of 2 bits. Additionally, the known data generated (or created) from the known data generator 110 are also inputted to the symbol processor 109. Herein, the known data consist of the known data symbol generated from the symbol domain. This is because the known data are used in the symbol domain of the receiving system. Also, it is more efficient to create a known data symbol sequence having the characteristics desired (or required) by the symbol domain.
- [35] Meanwhile, when the input data inputted to the symbol processor 109 correspond to the known data place holder that is converted to a symbol by the byte-symbol converter 108, the symbol processor 109 uses the known data generated from the



known data generator 110 instead of the known data place holder. The symbol processor 109 then generates and outputs a known data symbol at the beginning of the known data sequence so that the memory of the trellis encoder 113 is initialized to a pre-decided state. In order to do so, the memory value within the trellis encoder 113 should be inputted to the symbol processor 109.

- [36] Further, the memory value of the trellis encoder 113 may also be used in an additional signaling process for the enhanced data symbol. Additionally, the trellis encoder 113 is initialized at the beginning of the known data sequence because a plurality of output sequences may be generated depending upon the memory state of the trellis encoder 113 even when the known data sequence is inputted to the trellis encoder 113. Accordingly, the memory state of the trellis encoder 113 is first initialized to a pre-decided value and, then, when the known data are inputted, a desired known data output sequence may be obtained from the output of the trellis encoder 113.
- [37] The output symbol of the symbol processor 109 is inputted to the trellis encoder 113 so as to be trellis-encoded. The trellis encoder 113 pre-codes the data that are inputted as the upper bit among the output symbols of the symbol processor 109, and trellis-encodes the data that are inputted as the lower bit. Thereafter, the pre-coded data and the trellis-encoded data are outputted to the frame multiplexer 114. Meanwhile, the symbol processor 109 receives the 2-bit symbol, processes the received symbol with a plurality of process steps, and outputs the processed symbol. Therefore, the symbol should be converted back to bytes from the symbol-byte converter 111 so that the non-systematic RS encoder 112 can recalculate the RS parity from the output of the symbol processor 109. In other words, the input symbol is converted to byte units from the symbol-byte converter 111 and outputted to the non-systematic RS encoder 112. The non-systematic RS encoder 112 calculates the 20-byte RS parity for the data packet configured of 187 information bytes and outputs the calculated RS parity to the data interleaver 107. The data interleaver 107 receives the RS parity byte calculated and outputted from the non-systematic RS encoder 112 and replaces the non-systematic place holder that is not yet outputted with the received RS parity byte.
- [38] Herein, since the enhanced data symbol and the known data place holder are changed to different values by the symbol processor 109, a decoding error occurs when performing a RS decoding process in the conventional receiver. The non-systematic RS coding process is performed in order to prevent such decoding error from occurring. Meanwhile, the non-systematic RS encoder 112 receives the output of the known data generator 110 in order to receive in advance the known data being outputted later than the RS parity byte from the symbol-byte converter 111.
- [39] The frame multiplexer 114 inserts 4 segment synchronization symbols in each

output symbol of the trellis encoder 113, thereby configuring a data segment having 832 data symbols. More specifically, one field synchronization segment is inserted in each of the 312 data segments, so as to configure one data field, which is then outputted to the transmitting unit 120. The transmitting unit 120 inserts a pilot signal in the output of the frame multiplexer 114, the output having a segment synchronization signal and a field synchronization signal inserted therein. The transmitting unit 120 then modulates the pilot signal inserted data and converts the modulated data to an RF signal, which is transmitted through the antenna. Accordingly, the transmitting unit 120 includes a pilot inserter 121, a modulator 122, and a RF-UP converter 123. Furthermore, a pre-equalizer filter may be optionally included.

[40] As described above, the digital broadcast transmitting system may regularly insert known data within the data frame. FIG. 2 illustrates an example of a data structure of a signal, which regularly inserts and transmits known data sequences having identical patterns inserted in between actual data from the digital broadcast transmitting system. Referring to FIG. 2,  $A$  represents the number of symbols corresponding to the valid data, and  $B$  represents the number of symbols corresponding to the known data. Accordingly,  $B$  number of known data symbols are inserted and transmitted after each cycle (or period) of  $(A+B)$  number of symbols. Herein,  $A$  may correspond to one of the enhanced data, the main data, and a combination of the enhanced data and main data. And, in order to be differentiated from the known data,  $A$  data is referred to as valid data. The receiving system according to the present invention detects the place (or position) of the known data being regularly inserted and transmitted as described above. Simultaneously, during the process of detecting the known data, the receiving system estimates a coarse frequency offset. Thereafter, by using the detected known data place information and the estimated value of the coarse frequency offset (or coarse frequency offset estimation value), the receiving system estimates and compensates the carrier frequency offset with more accuracy.

[41] FIG. 3 illustrates a block diagram showing the structure of a demodulating unit within a digital broadcast (or television) receiving system according to an embodiment of the present invention. The demodulating unit includes a demodulator 301, a channel equalizer 302, a known sequence detector and coarse frequency offset detector 303, a Viterbi decoder 304, a data deinterleaver 305, a Reed-Solomon (RS) decoder/non-systematic RS parity remover 306, and a derandomizer 307. The digital broadcast receiving system also includes a main data packet remover 308, a packet deformatter 309, and an enhanced data processor 310.

[42] More specifically, the frequency of a specific channel tuned in a tuner outputs to the demodulator 301 and the known sequence detector and coarse frequency offset detector 303. The demodulator 301 performs carrier recovery and timing recovery on

the tuned channel frequency so as to create baseband signals. The baseband signals are then outputted to the channel equalizer 302 and the known sequence detector and coarse frequency offset detector 303. The channel equalizer 302 compensates the distortion included in the demodulated signal and, then, outputs the compensated signal to the Viterbi decoder 304.

[43] At this point, the known sequence detector and coarse frequency offset detector 303 detects the place (or position) of the known data sequence inserted by the transmitting system from the input/output data of the demodulator 301 (*i.e.*, either the data prior to demodulation or the data after demodulation). Accordingly, the detected place information is outputted to the demodulator 301 and the channel equalizer 302. Simultaneously, the coarse frequency offset is estimated and outputted to the demodulator 301. The process of detecting the known data place and the process of detecting the coarse frequency offset will be described in detail later on. By using the known data symbol sequence during the timing recovery or the carrier recovery, the demodulator 301 may enhance the demodulating performance. Similarly, the channel equalizer 302 may also use the known data to enhance the equalizing performance. Particularly, the demodulator 301 uses the known data place information and the estimated value of the coarse frequency offset both outputted from the known sequence detector and coarse frequency offset detector 303, so as to estimate and output the frequency offset with more accuracy.

[44] The Viterbi decoder 304 performs Viterbi decoding on the main data symbol and the enhanced data symbol outputted from the channel equalizer 302, so as to convert the symbol to bytes. Thereafter, the converted bytes are outputted to the data deinterleaver 305. Further, the 8-level decision values decided by the Viterbi decoder 304 are provided to the channel equalizer 302, thereby enhancing the equalizing performance. The data deinterleaver 305 performs an inverse process of the data interleaver included in the transmitting system then outputs the processed data to the RS encoder/non-systematic RS parity remover 306. When the received data packet corresponds to the main data packet, the RS encoder/non-systematic RS parity remover 306 performs a systematic RS-coding process. And, when the received data packet corresponds to the enhanced data packet, the RS encoder/non-systematic RS parity remover 306 removes the non-systematic RS parity byte inserted in the received data packet. Thereafter, the RS encoder/non-systematic RS parity remover 306 outputs the processed data packet to the data derandomizer 307.

[45] The data derandomizer 307 performs an inverse process of the randomizer included in the transmitting system on the output of the RS encoder/non-systematic RS parity remover 306. The data derandomizer 307 also inserts a MPEG synchronization byte in front of each packet, thereby outputting the processed data in 188-byte packet units.

The output of the data derandomizer 307 is outputted to a main MPEG decoder (not shown) and, at the same time, outputted to the main data packet remover 308.

Meanwhile, the main data packet remover 308 removes the 188-byte unit main data packet from the output of the derandomizer 307. Thereafter, the processed data are outputted to the packet deformatter 309. The packet deformatter 309 removes from the enhanced data packet the MPEG header bytes, the known data place holder bytes, and the null bits or repetition bits that were inserted for byte expansion, which were inserted in the enhanced data packet by the formatter of the transmitting system.

Thereafter, the processed data are outputted to the enhanced data processor 310. The enhanced data processor 310 performs an inverse process of the pre-processor 101 included in the transmitting system on the output of the packet deformatter 309, thereby outputting the finally processed enhanced data.

[46] FIG. 4 illustrates a block diagram showing the structure of a known sequence detector and coarse frequency offset detector shown in FIG. 3. More specifically, FIG. 4 illustrates an example an inputted signal being oversampled at a sampling rate of  $N$ . Herein,  $N$  represents a sampling rate of a received signal. Referring to FIG. 4, the known sequence detector and coarse frequency offset detector includes  $N$  number of partial correlation unit 411 to 41 $N$  configured in parallel, and a known data place detector and frequency offset decider 420. Herein, the first partial correlation unit 411 consists of a  $1/N$  decimator, and a partial correlator. The second partial correlation unit 412 consists of a 1 sample delay, a  $1/N$  decimator, and a partial correlator. And, the  $N^{\text{th}}$  partial correlation unit 41 $N$  consists of a  $N-1$  sample delay, a  $1/N$  decimator, and a partial correlator. These are used to match (or identify) the phase of each of the samples within the oversampled symbol with the phase of the original symbol, and to decimate the samples of the remaining phases, thereby performing partial correlation on each sample. More specifically, the input signal is decimated at a rate of  $1/N$  for each sampling phase, so as to pass through each partial correlation unit.

[47] For example, when the input signal is oversampled at sampling rate of 2 (*i.e.*, when  $N=2$ ), this indicates that two samples are included in one signal. In this case, two partial correlation units are required, and each  $1/N$  decimator becomes a  $1/2$  decimator. At this point, the  $1/N$  decimator of the first partial correlation unit 411 decimates (or removes), among the input samples, the samples located in-between symbol places (or positions). Then, the corresponding  $1/N$  decimator outputs the decimated sample to the partial correlator. Furthermore, the 1 sample delay of the second partial correlation unit 412 delays the input sample by 1 sample (*i.e.*, performs a 1 sample delay on the input sample) and outputs the delayed input sample to the  $1/N$  decimator. Subsequently, among the samples inputted from the 1 sample delay, the  $1/N$  decimator of the second partial correlation unit 412 decimates (or removes) the samples located in-between

symbol places (or positions). Thereafter, the corresponding 1/N decimator outputs the decimated sample to the partial correlator.

[48] After each predetermined period of the symbol, each of the partial correlators outputs a correlation value and an estimation value of the frequency offset estimated at that particular moment to the known data place detector and frequency offset decider 420. The known data place detector and frequency offset decider 420 stores the output of the partial correlators corresponding to each sampling phase during an data group cycle or a pre-decided cycle. Thereafter, the known data place detector and frequency offset decider 420 decides a position (or place) corresponding to the highest correlation value, among the stored values, as the place (or position) for receiving the known data. Simultaneously, the known data place detector and frequency offset decider 420 finally decides the estimation value of the frequency offset estimated at the moment corresponding to the highest correlation value as the coarse frequency offset value of the receiving system.

[49] FIG. 5 illustrates a block diagram showing the structure of one of the partial correlators shown in FIG. 4. During the step of detecting known data, since a frequency offset is included in the received signal, each partial correlator divides the known data, which is known according to an agreement between the transmitting system and the receiving system, to K number of parts each having an L symbol length, thereby correlating each divided part with the corresponding part of the received signal. In order to do so, each partial correlator includes K number of phase and magnitude detector 511 to 51K each formed in parallel, an adder 520, and a coarse frequency offset estimator 530.

[50] The first phase and magnitude size detector 511 includes an L symbol buffer 511-2, a multiplier 511-3, an accumulator 511-4, and a squarer 511-5. Herein, the first phase and magnitudesize detector 511 calculates the correlation value of the known data having a first L symbol length among the K number of sections.

[51] Also, the second phase and magnitudesize detector 512 includes an L symbol delay 512-1, an L symbol buffer 512-2, a multiplier 512-3, an accumulator 512-4, and a squarer 512-5. Herein, the second phase and size magnitude detector 512 calculates the correlation value of the known data having a second L symbol length among the K number of sections.

[52] Finally, the K<sup>th</sup> phase and magnitude size detector 51K includes a (K-1)L symbol delay 51K-1, an L symbol buffer 51K-2, a multiplier 51K-3, an accumulator 51K-4, and a squarer 51K-5. Herein, the K<sup>th</sup> phase and magnitude size detector 51K calculates the correlation value of the known data having an K<sup>th</sup> L symbol length among the K number of sections.

[53] Referring to FIG. 5,  $\{P_0, P_1, \dots, P_{KL-1}\}$  each being multiplied with the received signal

in the multiplier represents the known data known by both the transmitting system and the receiving system. And, \* represents a complex conjugate. For example, in the first phase and magnitude size detector 511, the signal outputted from the 1/N decimator of the first partial correlation unit 411, shown in FIG. 4, is temporarily stored in the L symbol buffer 511-2 of the first phase and magnitude size detector 511 and then inputted to the multiplier 511-3. The multiplier 511-3 multiplies the output of the L symbol buffer 511-2 with the complex conjugate of the known data parts  $P_0, P_1, \dots, P_{KL-1}$ , each having a first L symbol length among the known K number of sections. Then, the multiplied result is outputted to the accumulator 511-4. During the L symbol period, the accumulator 511-4 accumulates the output of the multiplier 511-3 and, then, outputs the accumulated value to the squarer 511-5 and the coarse frequency offset estimator 530. The output of the accumulator 511-4 is a correlation value having a phase and a magnitude size. Accordingly, the squarer 511-5 calculates an absolute (or magnitude) value of the output of the accumulator 511-4 and squares the calculated absolute (or magnitude) value, thereby obtaining the magnitude-square of the correlation value. The obtained magnitude-square size is then inputted to the adder 520.

[54] The adder 520 adds the output of the squarers corresponding to each magnitude and phase detector 511 to 51K. Then, the adder 520 outputs the added result to the known data place detector and frequency offset decider 420. Also, the coarse frequency offset estimator 520 receives the output of the accumulator corresponding to each magnitude size and phase detector 511 to 51K, so as to estimate the coarse frequency offset at each corresponding sampling phase. Thereafter, the coarse frequency offset estimator 520 outputs the estimated offset value to the known data place detector and frequency offset decider 420. When the K number of inputs that are outputted from the accumulator of each phase and magnitude size detector 511 to 51K are each referred to as  $\{Z_0, Z_1, \dots, Z_{K-1}\}$ , the output of the coarse frequency offset estimator 530 may be obtained by using Equation 1 shown below.

[55]

[56] Equation 1

[57]

$$\omega_{coarse} = \frac{1}{L} \arctan \left\{ \frac{\sum_{n=0}^{K-1} (|Z_n| \sin \theta_n)}{\sum_{n=0}^{K-1} (|Z_n| \cos \theta_n)} \right\}$$

[58] The known data place detector and frequency offset decider 420 stores the output output of the partial correlator corresponding to each sampling phase during an data group cycle or a pre-decided cycle. Then, among the stored correlation values, the known data place detector and frequency offset decider 420 decides the place (or position) corresponding to the highest correlation value as the place for receiving the

known data. Furthermore, the known data place detector and frequency offset decider 420 decides the estimated value of the frequency offset taken (or estimated) at the point of the highest correlation value as the coarse frequency offset value of the receiving system. For example, if the output of the partial correlator corresponding to the second partial correlator includes the highest value at one place, the place corresponding to the highest value is decided as the known data place. Thereafter, the coarse frequency offset estimated at the place by the second partial correlation unit 412 is decided as the final coarse frequency offset, which is then outputted.

[59] FIG. 6 illustrates a detailed block diagram showing the structure of a frequency synchronizer within the demodulator 301 shown in FIG. 3 according to an embodiment of the present invention. More specifically, the frequency synchronizer includes a multiplier 610, a controller 611, a fine frequency offset estimator 612, a loop filter 613, a multiplexer (MUX) 614, a numerically controlled oscillator (NCO) 615, and a ROM 616. The data received by a tuner is inputted to the multiplier 610 of the frequency synchronizer included in the demodulator 301. The known data place information detected by the known sequence detector and coarse frequency offset detector 303 is inputted to the controller 611 and the fine frequency offset estimator 612. Thereafter, the coarse frequency offset estimation value is inputted to the multiplexer 614. The controller 611 generates a select signal for selecting the input of the multiplexer 614. Subsequently, the controller 611 outputs the generated select signal to the multiplexer 614.

[60] More specifically, when the known sequence detector and coarse frequency offset detector 303 detects the known data and estimates the coarse frequency offset, the controller 611 generates the select signal so that the output of the multiplexer 614 is decided as the coarse frequency offset estimation value. The coarse frequency offset estimation value is inputted to the NCO 615 through the multiplexer 614. Subsequently, the NCO 615 generates a compensation frequency corresponding to the inputted coarse frequency offset and outputs the generated compensation frequency to the ROM 616. The ROM 616 outputs a complex sine wave corresponding to the compensation frequency to the multiplier 610. Thereafter, the multiplier 610 multiplies the complex sine wave of the ROM 616 to the output signal of the tuner, thereby outputting a baseband signal having its coarse frequency offset compensated to the fine frequency offset estimator 612 and the channel equalizer 302.

[61] Meanwhile, depending upon the known data place information outputted from the known sequence detector and coarse frequency offset detector 303, the fine frequency offset estimator 612 estimates the fine frequency offset from the output of the multiplier 610. Then, the fine frequency offset estimator 612 outputs the estimated offset to the multiplexer 614. Additionally, the controller 611 changes the select signal

of the multiplexer 614 so that the multiplexer 614 selects the output of the fine frequency offset estimator 612, at the point where the fine frequency offset estimation value is outputted from the fine frequency offset estimator 612. Accordingly, the fine frequency offset estimation value is inputted to the NCO 615 through the multiplexer 614. The next process steps are identical to those of the coarse frequency offset compensating process and, the description of the same will, therefore, be omitted for simplicity.

[62] When the frequency synchronization is stabilized, the controller 611 changes the select signal of the multiplexer 614 so that the frequency synchronizer is operated in a detection mode in order to maintain the frequency synchronization. In other words, the select signal is changed so that the output of the loop filter 613 becomes the output of the multiplexer 614. Accordingly, the fine frequency offset estimation value is inputted to the NCO 615 through the loop filter 613 and the multiplexer 614. The next process steps are identical to those of the coarse frequency offset compensating process and, the description of the same will, therefore, be omitted for simplicity. More specifically, the fine frequency offset estimator 612 uses the known data that are regularly (or periodically) repeated after each cycle, so as to output a frequency offset estimation value after a predetermined cycle and to decide the outputted estimation value as the outputs of the loop filter 613 and the multiplexer 614. Thus, the frequency synchronization may be maintained.

[63] Meanwhile, by including a multiplexer 620, the known sequence detector and coarse frequency offset detector 303 is capable of detecting the place (or position) of a known data sequence, that is inserted by the transmitting system, from the data prior to frequency synchronization or the data after frequency synchronization. In order to do so, when the frequency synchronizer is operated in an acquisition mode, the controller 611 generates a select signal so that the input data of the multiplier 610 (*i.e.*, the data prior to frequency offset compensation) become the output of the multiplexer 620. Conversely, when the frequency synchronizer is operated in a detection mode, the controller 611 generates a select signal so that the output data of the multiplier 610 (*i.e.*, the data after frequency offset compensation) become the output of the multiplexer 620. Depending upon the select signal, the multiplexer 620 selects one of the input signal and the output signal of the multiplier 610, thereby providing the selected signal to the known sequence detector and coarse frequency offset detector 303.

[64] FIG. 7 illustrates a block diagram showing the structure of the fine frequency offset estimator 612 shown in FIG. 6 according to an embodiment of the present invention. Herein, the fine frequency offset estimator 612 operated in accordance with the known data place information detected by the known sequence detector and coarse frequency offset detector 303. In FIG. 7, the step of receiving the known data place information



by the known sequence detector and coarse frequency offset detector 303 is omitted for simplicity. Referring to FIG. 7, the fine frequency offset estimator 612 includes a first N symbol buffer 711, a K symbol delay 712, a second N symbol buffer 713, a conjugator 714, a multiplier 715, an accumulator 716, and a phase detector 717. The fine frequency offset estimator 612 having the above-described structure will now be described in detail with respect to an operation example during a known data section.

[65] The first N symbol buffer 711 may store a maximum of N number of symbol being inputted thereto. The symbol data that are temporarily stored in the first N symbol buffer 711 are then inputted to the multiplier 715. At the same time, the inputted symbol is inputted to the K symbol delay 712 so as to be delayed by K symbols. Thereafter, the delayed symbol passes through the second N symbol buffer 713 so as to be conjugated by the conjugator 714. Thereafter, the conjugated symbol is inputted to the multiplier 715. The multiplier 715 multiplies the output of the first N symbol buffer 711 and the output of the conjugator 714. Then, the multiplier 715 outputs the multiplied result to the accumulator 716. Subsequently, the accumulator 716 accumulates the output of the multiplier 715 during N symbol periods, thereby outputting the accumulated result to the phase detector 717. The phase detector 717 extracts the corresponding phase information from the output of the accumulator 716, which is then outputted to the multiplexer 614. Herein, the phase information becomes the fine frequency offset estimation value.

[66] More specifically, at the point where the input of the known data ends or at a desired point, the fine frequency offset estimator 612 accumulates during an N symbol period multiplication of the complex conjugate of N number of the input data stored in the first N symbol buffer 711 and the complex conjugate of the N number of the input data that are delayed by K symbols and stored in the second N symbol buffer 713. Thereafter, the phase value is extracted accordingly. At this point, it is preferable that the input signals stored in the first N symbol buffer 711 and in the second N symbol buffer 713 correspond to signals each being transmitted by the same known data and passing through almost the same channel. Otherwise, due to the influence of the transmission channel, the frequency offset estimating performance may be largely deteriorated.

[67] Further, the values N and K of the fine frequency offset estimator shown in FIG. 7 may be diversely decided. This is because a particular portion of the known data that are identically repeated may be used herein. For example, when the data having the structure described in FIG. 2 are being transmitted, N may be set as B (*i.e.*,  $N = B$ ), and K may be set as  $(A + B)$  (*i.e.*,  $K = A + B$ ). The frequency offset estimation value range of the fine frequency offset estimator 612 is decided in accordance with the value K. If the value K is large, then the frequency offset estimation value range becomes smaller.

Alternatively, if the value  $K$  is small, then the frequency offset estimation value range becomes larger. Therefore, when the data having the structure of FIG. 2 is transmitted, and if the repetition cycle ( $A + B$ ) of the known data is long, then the frequency offset estimation value range becomes smaller.

[68] In this case, even if the coarse frequency offset is estimated by the known sequence detector and coarse frequency offset detector 303 and the estimated value is compensated by the demodulator 301, the remaining frequency offset after compensation will exceed the estimation range of the fine frequency offset estimator. In order to overcome such problems, the known data sequence that is regularly transmitted may be configured of a repetition of a same data portion by using a cyclic extension process. For example, as shown in FIG. 2, if the known data sequence is configured of two identical portions having the length of  $B/2$ , then the  $N$  and  $K$  values of the fine frequency offset estimator shown in FIG. 7 may be respectively set as  $B/2$  and  $B/2$  (i.e.,  $N = B/2$  and  $K = B/2$ ). In this case, the estimation value range may become larger than when using repeated known data.

[69] FIG. 8 illustrates a block diagram showing the structure of a digital broadcast transmitting system according to an embodiment of the present invention. The digital broadcast(or DTV) transmitting system includes a pre-processor 810, a packet multiplexer 821, a data randomizer 822, a Reed-Solomon (RS) encoder/non-systematic RS encoder 823, a data interleaver 824, a parity byte replacer 825, a non-systematic RS encoder 826, a frame multiplexer 828, and a transmitting unit 830. The pre-processor 810 includes an enhanced data randomizer 811, a RS frame encoder 812, a block processor 813, a group formatter 814, a data deinterleaver 815, and a packet formatter 816.

[70] In the present invention having the above-described structure, main data are inputted to the packet multiplexer 821. Enhanced data are inputted to the enhanced data randomizer 811 of the pre-processor 810, wherein an additional coding process is performed so that the present invention can respond swiftly and appropriately against noise and change in channel. The enhanced data randomizer 811 randomizes the received enhanced data and outputs the randomized enhanced data to the RS frame encoder 812. At this point, by having the enhanced data randomizer 811 perform the randomizing process on the enhanced data, the randomizing process on the enhanced data by the data randomizer 822 in a later process may be omitted. Either the randomizer of the conventional broadcast system may be used as the randomizer for randomizing the enhanced data, or any other type of randomizer may be used herein.

[71] The RS frame encoder 812 receives the randomized enhanced data and performs at least one of an error correction coding process and an error detection coding process on the received data. Accordingly, by providing robustness to the enhanced data, the data

can scatter group error that may occur due to a change in the frequency environment. Thus, the data can respond appropriately to the frequency environment which is very poor and liable to change. The RS frame multiplexer 812 also includes a process of mixing in row units many sets of enhanced data each having a pre-determined size. By performing an error correction coding process on the inputted enhanced data, the RS frame encoder 812 adds data required for the error correction and, then, performs an error detection coding process, thereby adding data required for the error detection process. The error correction coding uses the RS coding method, and the error detection coding uses the cyclic redundancy check (CRC) coding method. When performing the RS coding process, parity data required for the error correction are generated. And, when performing the CRC coding process, CRC data required for the error detection are generated.

[72] The RS frame encoder 812 performs CRC coding on the RS coded enhanced data in order to create the CRC code. The CRC code that is generated by the CRC coding process may be used to indicate whether the enhanced data have been damaged by an error while being transmitted through the channel. The present invention may adopt other types of error detection coding methods, apart from the CRC coding method, and may also use the error correction coding method so as to enhance the overall error correction ability of the receiving system. For example, assuming that the size of one RS frame is  $187 \cdot N$  bytes, that  $(235, 187)$ -RS coding process is performed on each column within the RS frame, and that a CRC coding process using a 2-byte (*i.e.*, 16-bit) CRC checksum, then a RS frame having the size of  $187 \cdot N$  bytes is expanded to a RS frame of  $235 \cdot (N+2)$  bytes. The RS frame expanded by the RS frame encoder 812 is inputted to the block processor 813. The block processor 813 codes the RS-coded and CRC-coded enhanced data at a coding rate of  $G/H$ . Then, the block processor 813 outputs the  $G/H$ -rate coded enhanced data to the group formatter 814. In order to do so, the block processor 813 identifies the block data bytes being inputted from the RS frame encoder 812 as bits.

[73] The block processor 813 may receive supplemental information data such as signaling information, which include information on the system, and identifies the supplemental information data bytes as data bits. Herein, the supplemental information data, such as the signaling information, may equally pass through the enhanced data randomizer 811 and the RS frame encoder 812 so as to be inputted to the block processor 813. Alternatively, the supplemental information data may be directly inputted to the block processor 813 without passing through the enhanced data randomizer 811 and the RS frame encoder 812. The signaling information corresponds to information required for receiving and processing data included in the data group in the receiving system. Such signaling information includes data group information,

multiplexing information, and burst information.

[74] As a G/H-rate encoder, the E-VSB block processor 813 codes the inputted data at a coding rate of G/H and then outputs the G/H-rate coded data. For example, if 1 bit of the input data is coded to 2 bits and outputted, then G is equal to 1 and H is equal to 2 (*i.e.*, G=1 and H=2). Alternatively, if 1 bit of the input data is coded to 4 bits and outputted, then G is equal to 1 and H is equal to 4 (*i.e.*, G=1 and H=4). As an example of the present invention, it is assumed that the block processor 813 performs a coding process at a coding rate of 1/2 (also referred to as a 1/2-rate coding process) or a coding process at a coding rate of 1/4 (also referred to as a 1/4-rate coding process). More specifically, the block processor 813 codes the received enhanced data and supplemental information data, such as the signaling information, at either a coding rate of 1/2 or a coding rate of 1/4. Thereafter, the supplemental information data, such as the signaling information, are identified and processed as enhanced data.

[75] Since the 1/4-rate coding process has a higher coding rate than the 1/2-rate coding process, greater error correction ability may be provided. Therefore, in a later process, by allocating the 1/4-rate coded data in an area with deficient receiving performance within the group formatter 814, and by allocating the 1/2-rate coded data in an area with excellent receiving performance, the difference in the overall performance may be reduced. More specifically, in case of performing the 1/2-rate coding process, the E-VSB block processor 813 receives 1 bit and codes the received 1 bit to 2 bits (*i.e.*, 1 symbol). Then, the E-VSB block processor 813 outputs the processed 2 bits (or 1 symbol). On the other hand, in case of performing the 1/4-rate coding process, the E-VSB block processor 813 receives 1 bit and codes the received 1 bit to 4 bits (*i.e.*, 2 symbols). Then, the E-VSB block processor 813 outputs the processed 4 bits (or 2 symbols). Additionally, the block processor 813 performs a block interleaving process in symbol units on the symbol-coded data. Subsequently, the block processor 813 converts to bytes the data symbols that are block-interleaved and have the order rearranged.

[76] The group formatter 814 inserts the enhanced data outputted from the block processor 813 (herein, the enhanced data may include supplemental information data such as signaling information including transmission information) in a corresponding area within the data group, which is configured according to a pre-defined rule. Furthermore, in relation with the data deinterleaving process, various types of places holders or known data are also inserted in corresponding areas within the data group. At this point, the data group may be described by at least one hierarchical area. Herein, the data allocated to the each area may vary depending upon the characteristic of each hierarchical area. Additionally, each group is configured to include a field synchronization signal.

[77] The present invention shows an example of the data group being divided into three hierarchical areas: a head area, a body area, and a tail area. Accordingly, in the data group that is inputted for the data deinterleaving process, data are first inputted to the head area, then inputted to the body area, and inputted finally to the tail area. In the example of the present invention, the head, body, and tail areas are configured so that the body area is not mixed with the main data area within the data group. Furthermore, in the present invention, the head, body, and tail areas may each be divided into lower hierarchical areas. For example, the head area may be divided into 3 lower hierarchical areas: a far head (FH) area, a middle head (MH) area, and a near head (NH) area. The body area may be divided into 4 lower hierarchical areas: a first lower body (B1) area, a second lower body (B2) area, a third lower body (B3) area, and a fourth lower body (B4) area. And, finally, the tail area may be divided into 2 lower hierarchical areas: a far tail (FT) area and a near tail (NT) area.

[78] In the example of the present invention, the group formatter 814 inserts the enhanced data being outputted from the block processor 813 to the middle head (MH) area, the near head (NH) area, the first to fourth lower body (B1 to B4) areas, and the near tail (NT) area. Herein, the type of enhanced data may vary depending upon the characteristic of each area. The data group is divided into a plurality of areas so that each area may be used for different purposes. More specifically, areas having less interference with the main data may show more enhanced receiving performance as compared with area having more interference with the main data. Additionally, when using the system in which the known data are inserted in the data group and then transmitted, and when a long set of consecutive known data is to be periodically (or regularly) inserted in the enhanced data, the body area is capable of regularly receiving such enhanced data having a predetermined length. However, since the enhanced data may be mixed with the main data in the head and tail areas, it is difficult to regularly insert the known data in these areas, and it is also difficult to insert long known data sets that are consecutive in these areas.

[79] Details such as the size of the data group, the number of hierarchical areas within the data group and the size of each hierarchical area, and the number of enhanced data bytes that may be inserted in each hierarchical area may vary depending upon the design of the system designer. Therefore, the above-described embodiment is merely an example that can facilitate the description of the present invention. In the group formatter 814, the data group may be configured to include a position (or place) in which the field synchronization signal is to be inserted. When assuming that the data group is divided into a plurality of hierarchical areas as described above, the block processor 813 may code the data that are to be inserted in each area at different coding rates.

[80] In the present invention, based upon the areas that are each expected to show different performance after the equalization process when using the channel information that may be used for the channel equalization process in the receiving system, a different coding rate may be applied to each of these areas. For example, the block processor 813 codes the enhanced data that are to be inserted in the near head (NH) area and the first to fourth lower body (B1 to B4) areas at a 1/2-coding rate. Thereafter, the group formatter 814 may insert the 1/2-rate coded enhanced data in the near head (NH) area and the first to fourth lower body (B1 to B4) areas. On the other hand, the block processor 813 codes the enhanced data that are to be inserted in the middle head (MH) area and the near tail (NT) area at a 1/4-coding rate, which has greater error correction ability than the 1/2-coding rate. Subsequently, the group formatter 814 may insert the 1/2-rate coded enhanced data in the middle head (MH) area and the near tail (NT) area. Furthermore, the block processor 813 codes the enhanced data that are to be inserted in the far head (FH) area and the far tail (FT) area at a coding rate having even greater error correction ability than the 1/4-coding rate. Thereafter, the group formatter 814 may insert the coded enhanced data either in the far head (FH) and far tail (FT) areas or in a reserved area for future usage.

[81] Apart from the enhanced data, the group formatter 813 may also insert supplemental information data such as signaling information indicating the overall transmission information in the data group. Also, apart from the coded enhanced data outputted from the block processor 813, and in relation with the data deinterleaving process in a later process, the group formatter 814 may also insert a MPEG header place holder, a non-systematic RS parity place holder, and a main data place holder in the data group. Herein, the main data group place holder is inserted because the enhanced data and the main data may be mixed in the head and tail areas depending upon the input of the data deinterleaver. For example, based upon the output of the data after being deinterleaved, the place holder for the MPEG header may be allocated to the front of each data packet. Additionally, the group formatter 814 may either insert known data generated according to a pre-defined rule, or insert a known data place holder for inserting known data in a later process. Furthermore, a place holder for the initialization of the trellis encoder module 827 is inserted in a corresponding area. For example, the initialization data place holder may be inserted at the beginning (or front) of the data place sequence.

[82] The output of the group formatter 814 is inputted to the data deinterleaver 815. And, the data deinterleaver 815 performs an inverse process of the data interleaver deinterleaving the data and place holder within the data group being outputted from the group formatter 814. Thereafter, the data deinterleaver 815 outputs the deinterleaved data to the packet formatter 816. Among the data deinterleaved and inputted, the

packet formatter 816 removes the main data place holder and RS parity place holder that were allocated for the deinterleaving process from the inputted deinterleaved data. Thereafter, the remaining portion of the corresponding data is grouped, and 4 bytes of MPEG header are inserted therein. The 4-byte MPEG header is configured of a 1-byte MPEG synchronization byte added to the 3-byte MPEG header place holder.

[83] When the group formatter 814 inserts the known data place holder, the packet formatter 816 may either insert actual known data in the known data place holder or output the known data place holder without any change or modification for a replacement insertion in a later process. Afterwards, the packet formatter 816 divides the data within the above-described packet-formatted data group into 188-byte unit enhanced data packets (*i.e.*, MPEG TS packets), which are then provided to the packet multiplexer 821. The packet multiplexer 821 multiplexes the 188-byte unit enhanced data packet and main data packet outputted from the packet formatter 816 according to a pre-defined multiplexing method. Subsequently, the multiplexed data packets are outputted to the data randomizer 822. The multiplexing method may be modified or altered in accordance with diverse variables of the system design.

[84] As an example of the multiplexing method of the packet multiplexer 821, the enhanced data burst section and the main data section may be identified along a time axis (or a chronological axis) and may be alternately repeated. At this point, the enhanced data burst section may transmit at least one data group, and the main data section may transmit only the main data. The enhanced data burst section may also transmit the main data. If the enhanced data are outputted in a burst structure, as described above, the receiving system receiving only the enhanced data may turn the power on only during the burst section so as to receive the enhanced data, and may turn the power off during the main data section in which main data are transmitted, so as to prevent the main data from being received, thereby reducing the power consumption of the receiving system.

[85] When the data being inputted correspond to the main data packet, the data randomizer 822 performs the same randomizing process of the conventional randomizer. More specifically, the MPEG synchronization byte included in the main data packet is discarded and a pseudo random byte generated from the remaining 187 bytes is used so as to randomize the data. Thereafter, the randomized data are outputted to the RS encoder/non-systematic RS encoder 823. However, when the inputted data correspond to the enhanced data packet, the MPEG synchronization byte of the 4-byte MPEG header included in the enhanced data packet is discarded, and data randomizing is performed only on the remaining 3-byte MPEG header. Randomizing is not performed on the remaining portion of the enhanced data. Instead, the remaining portion of the enhanced data is outputted to the RS encoder/non-systematic RS encoder

823. This is because the randomizing process has already been performed on the enhanced data by the enhanced data randomizer 811 in an earlier process. Herein, a data randomizing process may or may not be performed on the known data (or known data place holder) and the initialization data place holder included in the enhanced data packet.

[86] The RS encoder/non-systematic RS encoder 823 RS-codes the data randomized by the data randomizer 822 or the data bypassing the data randomizer 822. Then, the RS encoder/non-systematic RS encoder 823 adds a 20-byte RS parity to the coded data, thereby outputting the RS-parity-added data to the data interleaver 824. At this point, if the inputted data correspond to the main data packet, the RS encoder/non-systematic RS encoder 823 performs a systematic RS-coding process identical to that of the conventional receiver on the inputted data, thereby adding the 20-byte RS parity at the end of the 187-byte data. Alternatively, if the inputted data correspond to the enhanced data packet, the 20 bytes of RS parity gained by performing the non-systematic RS-coding are respectively inserted in the decided parity byte places within the enhanced data packet. Herein, the data interleaver 824 corresponds to a byte unit convolutional interleaver. The output of the data interleaver 824 is inputted to the parity byte replacer 825 and the non-systematic RS encoder 826.

[87] Meanwhile, a memory within the trellis encoding module 827, which is positioned after the parity byte replacer 825, should first be initialized in order to allow the output data of the trellis encoding module 827 so as to become the known data defined based upon an agreement between the receiving system and the transmitting system. More specifically, the memory of the trellis encoding module 827 should first be initialized before the known data sequence being inputted is trellis-encoded. At this point, the beginning of the known data sequence that is inputted corresponds to the initialization data place holder inserted by the group formatter 814 and not the actual known data. Therefore, a process of generating initialization data right before the trellis-encoding of the known data sequence being inputted and a process of replacing the initialization data place holder of the corresponding trellis encoding module memory with the newly generated initialization data are required.

[88] A value of the trellis memory initialization data is decided based upon the memory status of the trellis encoding module 827, thereby generating the trellis memory initialization data accordingly. Due to the influence of the replace initialization data, a process of recalculating the RS parity, thereby replacing the RS parity outputted from the trellis encoding module 827 with the newly calculated RS parity is required. Accordingly, the non-systematic RS encoder 826 receives the enhanced data packet including the initialization data place holder that is to be replaced with the initialization data from the data interleaver 824 and also receives the initialization data from the



trellis encoding module 827. Thereafter, among the received enhanced data packet, the initialization data place holder is replaced with the initialization data. Subsequently, the RS parity data added to the enhanced data packet are removed. Then, a new non-systematic RS parity is calculated and outputted to the parity byte replacer 825. Accordingly, the parity byte replacer 825 selects the output of the data interleaver 824 as the data within the enhanced data packet, and selects the output of the non-systematic RS encoder 826 as the RS parity. Thereafter, the parity byte replacer 825 outputs the selected data.

[89] Meanwhile, if the main data packet is inputted, or if the enhanced data packet that does not include the initialization data place holder that is to be replaced, the parity byte replacer 825 selects the data and RS parity outputted from the data interleaver 824 and directly outputs the selected data to the trellis encoding module 827 without modification. The trellis encoding module 827 converts the byte-unit data to symbol-unit data and 12-way interleaves and trellis-encodes the converted data, which are then outputted to the frame multiplexer 828. The frame multiplexer 828 inserts field synchronization and segment synchronization signals in the output of the trellis encoding module 827 and then outputs the processed data to the transmitting unit 830. Herein, the transmitting unit 830 includes a pilot inserter 831, a modulator 832, and a radio frequency (RF) up-converter 833. The operation of the transmitting unit 830 is identical to the conventional transmitters. Therefore, a detailed description of the same will be omitted for simplicity.

[90] FIG. 9 illustrates a block diagram of a demodulating unit included in the receiving system according to another embodiment of the present invention. Herein, the demodulating unit may effectively process signals transmitted from the transmitting system shown in FIG. 8. Referring to FIG. 9, the demodulating unit includes a demodulator 901, a channel equalizer 902, a known data detector 903, a block decoder 904, an enhanced data deformatter 905, a RS frame decoder 906, an enhanced data derandomizer 907, a data deinterleaver 908, a RS decoder 909, and a main data derandomizer 910. For simplicity, the demodulator 901, the channel equalizer 902, the known data detector 903, the block decoder 904, the enhanced data deformatter 905, the RS frame decoder 906, and the enhanced data derandomizer 907 will be referred to as an enhanced data processor. And, the data deinterleaver 908, the RS decoder 909, and the main data derandomizer 910 will be referred to as a main data processor.

[91] More specifically, the enhanced data including known data and the main data are received through the tuner and inputted to the demodulator 901 and the known data detector 903. The demodulator 901 performs automatic gain control, carrier recovery, and timing recovery on the data that are being inputted, thereby creating baseband data, which are then outputted to the equalizer 902 and the known data detector 903.

The equalizer 902 compensates the distortion within the channel included in the demodulated data. Then, the equalizer 902 outputs the compensated data to the block decoder 904.

[92] At this point, the known data detector 903 detects the known data place inserted by the transmitting system to the input/output data of the demodulator 901 (*i.e.*, data prior to demodulation or data after demodulation). Then, along with the position information, the known data detector 903 outputs the symbol sequence of the known data generated from the corresponding position to the demodulator 901 and the equalizer 902. Additionally, the known data detector 903 outputs information enabling the block decoder 904 to identify the enhanced data being additionally encoded by the transmitting system and the main data that are not additionally encoded to the block decoder 904. Furthermore, although the connection is not shown in FIG. 9, the information detected by the known data detector 903 may be used in the overall receiving system and may also be used in the enhanced data formatter 905 and the RS frame decoder 906.

[93] By using the known data symbol sequence when performing the timing recovery or carrier recovery, the demodulating performance of the demodulator 901 may be enhanced. Similarly, by using the known data, the channel equalizing performance of the channel equalizer 902 may be enhanced. Furthermore, by feeding-back the demodulation result of the block demodulator 904, the channel equalizing performance may also be enhanced. Herein, the channel equalizer 902 may perform channel equalization through various methods. In the present invention, a method of estimating a channel impulse response (CIR) for performing the channel equalization process will be given as an example of the present invention. More specifically, in the present invention, the channel impulse response (CIR) is differently estimated and applied in accordance with each hierarchical area within the data group that are transmitted from the transmitting system. Furthermore, by using the known data having the position (or place) and contents pre-known according to an agreement between the transmitting system and the receiving system, so as to estimate the CIR, the channel equalization process may be processed with more stability.

[94] In the present invention, one data group that is inputted for channel equalization is divided into three hierarchical areas: a head area, a body area, and a tail area. Then, each of the areas is divided into lower hierarchical areas. More specifically, the head area may be divided into a far head (FH) area, a middle head (MH) area, and a near head (NH) area. And, the tail area may be divided into a far tail (FT) area and a near tail (NT) area. Furthermore, based upon a long known data sequence, the body area may be divided into 4 lower hierarchical areas: a first lower body (B1) area, a second lower body (B2) area, a third lower body (B3) area, and a fourth lower body (B4) area.

In performing channel equalization on the data within the data group by using the CIR estimated from the field synchronization signal and the known data sequence, and in accordance with the characteristic of each area, either one of the estimated CIRs may be directly used without modification, or a CIR created by interpolating or extrapolating a plurality of CIRs may be used.

[95] Meanwhile, if the data being channel equalized and then inputted to the block decoder 904 correspond to the enhanced data on which additional encoding and trellis encoding are both performed by the transmitting system, trellis-decoding and additional decoding processes are performed as inverse processes of the transmitting system. Alternatively, if the data being channel equalized and then inputted to the block decoder 904 correspond to the main data on which additional encoding is not performed and only trellis-encoding is performed by the transmitting system, only the trellis-decoding process is performed. The data group decoded by the block decoder 904 is inputted to the enhanced data deformatter 905, and the main data packet is inputted to the data deinterleaver 908.

[96] More specifically, if the inputted data correspond to the main data, the block decoder 904 performs Viterbi decoding on the inputted data, so as to either output a hard decision value or hard-decide a soft decision value and output the hard-decided result. On the other hand, if the inputted correspond to the enhanced data, the block decoder 904 outputs either a hard decision value or a soft decision value on the inputted enhanced data. In other words, if the data inputted to the block decoder 904 correspond to the enhanced data, the block decoder 904 performs a decoding process on the data encoded by the block processor and the trellis encoder of the transmitting system. At this point, the output of the RS frame encoder included in the pre-processor of the transmitting system becomes an external code, and the output of the block processor and the trellis encoder becomes an internal code. In order to show maximum performance of the external code when decoding such connection codes, the decoder of the internal code should output a soft decision value. Therefore, the block decoder 904 may output a hard decision value on the enhanced data. However, when required, it is more preferable that the block decoder 904 outputs a soft decision value.

[97] The present invention may also be used for configuring a reliability map using the soft decision value. The reliability map determines and indicates whether a byte corresponding to a group of 8 bits decided by the code of the soft decision value is reliable. For example, when an absolute value of the soft decision value exceeds a pre-determined threshold value, the value of the bit corresponding to the soft decision value code is determined to be reliable. However, if the absolute value does not exceed the pre-determined threshold value, then the value of the corresponding bit is determined to be not reliable. Further, if at least one bit among the group of 8 bits,

which are determined based upon the soft decision value, is determined to be not reliable, then the reliability map indicates that the entire byte is not reliable. Herein, the process of determining the reliability by 1-bit units is merely exemplary. The corresponding byte may also be indicated to be not reliable if a plurality of bits (*e.g.*, 4 bits) is determined to be not reliable.

- [98] Conversely, when all of the bits are determined to be reliable within one byte (*i.e.*, when the absolute value of the soft value of all bits exceeds the pre-determined threshold value), then the reliability map determines and indicates that the corresponding data byte is reliable. Similarly, when more than 4 bits are determined to be reliable within one data byte, then the reliability map determines and indicates that the corresponding data byte is reliable. The estimated numbers are merely exemplary and do not limit the scope and spirit of the present invention. Herein, the reliability map may be used when performing error correction decoding processes.
- [99] Meanwhile, the data deinterleaver 908, the RS decoder 909, and the main data derandomizer 910 are blocks required for receiving the main data. These blocks may not be required in a receiving system structure that receives only the enhanced data. The data deinterleaver 908 performs an inverse process of the data interleaver of the transmitting system. More specifically, the data deinterleaver 908 deinterleaves the main data being outputted from the block decoder 904 and outputs the deinterleaved data to the RS decoder 909. The RS decoder 909 performs systematic RS decoding on the deinterleaved data and outputs the systematically decoded data to the main data derandomizer 910. The main data derandomizer 910 receives the data outputted from the RS decoder 909 so as to generate the same pseudo random byte as that of the randomizer in the transmitting system. The main data derandomizer 910 then performs a bitwise exclusive OR (XOR) operation on the generated pseudo random data byte, thereby inserting the MPEG synchronization bytes to the beginning of each packet so as to output the data in 188-byte main data packet units.
- [100] Herein, the format of the data being outputted to the enhanced data deformatter 905 from the block decoder 904 is a data group format. At this point, the enhanced data deformatter 905 already knows the structure of the input data. Therefore, the enhanced data deformatter 905 identifies the system information including signaling information and the enhanced data from the data group. Thereafter, the identified signaling information is transmitted to where the system information is required, and the enhanced data are outputted to the RS frame decoder 906. The enhanced data deformatter 905 removes the known data, trellis initialization data, and MPEG header that were included in the main data and the data group and also removes the RS parity that was added by the RS encoder/non-systematic RS encoder of the transmitting system. Thereafter, the processed data are outputted to the RS frame decoder 906.

- [101] More specifically, the RS frame decoder 906 receives the RS-coded and CRC-coded enhanced data from the enhanced data deformatter 905 so as to configure the RS frame. The RS frame decoder 906 performs an inverse process of the RS frame encoder included in the transmitting system, thereby correcting the errors within the RS frame. Then, the 1-byte MPEG synchronization byte, which was removed during the RS frame coding process, is added to the error corrected enhanced data packet. Subsequently, the processed data are outputted to the enhanced data derandomizer 907. Herein, the enhanced data derandomizer 907 performs a derandomizing process, which corresponds to an inverse process of the enhanced data randomizer included in the transmitting system, on the received enhanced data. Then, by outputting the processed data, the enhanced data transmitted from the transmitting system can be obtained.
- [102] According to an embodiment of the present invention, the RS frame decoder 906 may also be configured as follows. The RS frame decoder 906 may perform a CRC syndrome check on the RS frame, thereby verifying whether or not an error has occurred in each row. Subsequently, the CRC checksum is removed and the presence of an error is indicated on a CRC error flag corresponding to each row. Then, a RS decoding process is performed on the RS frame having the CRC checksum removed in a column direction. At this point, depending upon the number of CRC error flags, a RS erasure decoding process may be performed. More specifically, by checking the CRC error flags corresponding to each row within the RS frame, the number of CRC error flags may be determined whether it is greater or smaller than the maximum number of errors, when RS decoding the number of rows with errors (or erroneous rows) in the column direction. Herein, the maximum number of errors corresponds to the number of parity bytes inserted during the RS decoding process. As an example of the present invention, it is assumed that 48 parity bytes are added to each column.
- [103] If the number of rows with CRC errors is equal to or smaller than the maximum number of errors (*e.g.*, 48), which may be corrected by the RS erasure decoding process, the RS erasure decoding process is performed on the RS frame in the column direction. Thereafter, the 48 bytes of parity data that were added at the end of each column are removed. However, if the number of rows with CRC errors is greater than the maximum number of errors (*e.g.*, 48), which may be corrected by the RS erasure decoding process, the RS erasure decoding process cannot be performed. In this case, the error may be corrected by performing a general RS decoding process.
- [104] As another embodiment of the present invention, the error correction ability may be enhanced by using the reliability map created when configuring the RS frame from the soft decision value. More specifically, the RS frame decoder 906 compares the absolute value of the soft decision value obtained from the block decoder 904 to the pre-determined threshold value so as to determine the reliability of the bit values that

are decided by the code of the corresponding soft decision value. Then, 8 bits are grouped to configure a byte. Then, the reliability information of the corresponding byte is indicated on the reliability map. Therefore, even if a specific row is determined to have CRC errors as a result of the CRC syndrome checking process of the corresponding row, it is not assumed that all of the data bytes included in the corresponding row have error. Instead, only the data bytes that are determined to be not reliable, after referring to the reliability information on the reliability map, are set to have errors. In other words, regardless of the presence of CRC errors in the corresponding row, only the data bytes that are determined to be not reliable (or unreliable) by the reliability map are set as erasure points.

[105] Thereafter, if the number of erasure points for each column is equal to or smaller than the maximum number of errors (*e.g.*, 48), the RS erasure decoding process is performed on the corresponding the column. Conversely, if the number of erasure points is greater than the maximum number of errors (*e.g.*, 48), which may be corrected by the RS erasure decoding process, a general decoding process is performed on the corresponding column. In other words, if the number of rows having CRC errors is greater than the maximum number of errors (*e.g.*, 48), which may be corrected by the RS erasure decoding process, either a RS erasure decoding process or a general RS decoding process is performed on a particular column in accordance with the number of erasure point within the corresponding column, wherein the number is decided based upon the reliability information on the reliability map. When the above-described process is performed, the error correction decoding process is performed in the direction of all of the columns included in the RS frame. Thereafter, the 48 bytes of parity data added to the end of each column are removed.

[106] FIG. 10 illustrates a block diagram showing the structure of a digital broadcast receiving system according to an embodiment of the present invention. Referring to FIG. 10, the digital broadcast receiving system includes a tuner 1001, a demodulating unit 1002, a demultiplexer 1003, an audio decoder 1004, a video decoder 1005, a native TV application manager 1006, a channel manager 1007, a channel map 1008, a first memory 1009, a data decoder 1010, a second memory 1011, a system manager 1012, a data broadcasting application manager 1013, a storage controller 1014, and a third memory 1015. Herein, the third memory 1015 is a mass storage device, such as a hard disk drive (HDD) or a memory chip. The tuner 1001 tunes a frequency of a specific channel through any one of an antenna, cable, and satellite. Then, the tuner 1001 down-converts the tuned frequency to an intermediate frequency (IF), which is then outputted to the demodulating unit 1002. At this point, the tuner 1001 is controlled by the channel manager 1007. Additionally, the result and strength of the broadcast signal of the tuned channel are also reported to the channel manager 1007.

The data that are being received by the frequency of the tuned specific channel include main data, enhanced data, and table data for decoding the main data and enhanced data.

[107] In the embodiment of the present invention, examples of the enhanced data may include data provided for data service, such as Java application data, HTML application data, XML data, and so on. The data provided for such data services may correspond either to a Java class file for the Java application, or to a directory file designating positions (or locations) of such files. Furthermore, such data may also correspond to an audio file and/or a video file used in each application. The data services may include weather forecast services, traffic information services, stock information services, services providing information quiz programs providing audience participation services, real time poll, user interactive education programs, gaming services, services providing information on soap opera (or TV series) synopsis, characters, original sound track, filing sites, services providing information on past sports matches, profiles and accomplishments of sports players, product information and product ordering services, services providing information on broadcast programs by media type, airing time, subject, and so on. The types of data services described above are only exemplary and are not limited only to the examples given herein. Furthermore, depending upon the embodiment of the present invention, the enhanced data may correspond to meta data. For example, the meta data use the XML application so as to be transmitted through a DSM-CC protocol.

[108] The demodulating unit 1002 performs VSB-demodulation and channel equalization on the signal being outputted from the tuner 1001, thereby identifying the main data and the enhanced data. Thereafter, the identified main data and enhanced data are outputted in TS packet units. Examples of the demodulating unit 1002 is shown in FIG. 3 and FIG. 9. The demodulating unit shown in FIG. 3 and FIG. 9 is merely exemplary and the scope of the present invention is not limited to the examples set forth herein. In the embodiment given as an example of the present invention, only the enhanced data packet outputted from the demodulating unit 1002 is inputted to the demultiplexer 1003. In this case, the main data packet is inputted to another demultiplexer (not shown) that processes main data packets. Herein, the storage controller 1014 is also connected to the other demultiplexer in order to store the main data after processing the main data packets. The demultiplexer of the present invention may also be designed to process both enhanced data packets and main data packets in a single demultiplexer.

[109] The storage controller 1014 is interfaced with the demultiplexer so as to control instant recording, reserved (or pre-programmed) recording, time shift, and so on of the enhanced data and/or main data. For example, when one of instant recording, reserved

(or pre-programmed) recording, and time shift is set and programmed in the receiving system (or receiver) shown in FIG. 10, the corresponding enhanced data and/or main data that are inputted to the demultiplexer are stored in the third memory 1015 in accordance with the control of the storage controller 1014. The third memory 1015 may be described as a temporary storage area and/or a permanent storage area. Herein, the temporary storage area is used for the time shifting function, and the permanent storage area is used for a permanent storage of data according to the user's choice (or decision).

[110] When the data stored in the third memory 1015 need to be reproduced (or played), the storage controller 1014 reads the corresponding data stored in the third memory 1015 and outputs the read data to the corresponding demultiplexer (*e.g.*, the enhanced data are outputted to the demultiplexer 1003 shown in FIG. 10). At this point, according to the embodiment of the present invention, since the storage capacity of the third memory 1015 is limited, the compression encoded enhanced data and/or main data that are being inputted are directly stored in the third memory 1015 without any modification for the efficiency of the storage capacity. In this case, depending upon the reproduction (or reading) command, the data read from the third memory 1015 pass through the demultiplexer so as to be inputted to the corresponding decoder, thereby being restored to the initial state.

[111] The storage controller 1014 may control the reproduction (or play), fast-forward, rewind, slow motion, instant replay functions of the data that are already stored in the third memory 1015 or presently being buffered. Herein, the instant replay function corresponds to repeatedly viewing scenes that the viewer (or user) wishes to view once again. The instant replay function may be performed on stored data and also on data that are currently being received in real time by associating the instant replay function with the time shift function. If the data being inputted correspond to the analog format, for example, if the transmission mode is NTSC, PAL, and so on, the storage controller 1014 compression encodes the inputted data and stored the compression-encoded data to the third memory 1015. In order to do so, the storage controller 1014 may include an encoder, wherein the encoder may be embodied as one of software, middleware, and hardware. Herein, an MPEG encoder may be used as the encoder according to an embodiment of the present invention. The encoder may also be provided outside of the storage controller 1014.

[112] Meanwhile, in order to prevent illegal duplication (or copies) of the input data being stored in the third memory 1015, the storage controller 1014 scrambles the input data and stores the scrambled data in the third memory 1015. Accordingly, the storage controller 1014 may include a scramble algorithm for scrambling the data stored in the third memory 1015 and a descramble algorithm for descrambling the data read from



the third memory 1015. Herein, the definition of scramble includes encryption, and the definition of descramble includes decryption. The scramble method may include using an arbitrary key (*e.g.*, control word) to modify a desired set of data, and also a method of mixing signals.

[113] Meanwhile, the demultiplexer 1003 receives the real-time data outputted from the demodulating unit 1002 or the data read from the third memory 1015 and demultiplexes the received data. In the example given in the present invention, the demultiplexer 1003 performs demultiplexing on the enhanced data packet. Therefore, in the present invention, the receiving and processing of the enhanced data will be described in detail. It should also be noted that a detailed description of the processing of the main data will be omitted for simplicity starting from the description of the demultiplexer 1003 and the subsequent elements.

[114] The demultiplexer 1003 demultiplexes enhanced data and program specific information/program and system information protocol (PSI/PSIP) tables from the enhanced data packet inputted in accordance with the control of the data decoder 1010. Thereafter, the demultiplexed enhanced data and PSI/PSIP tables are outputted to the data decoder 1010 in a section format. In order to extract the enhanced data from the channel through which enhanced data are transmitted and to decode the extracted enhanced data, system information is required. Such system information may also be referred to as service information. The system information may include channel information, event information, *etc.* In the embodiment of the present invention, the PSI/PSIP tables are applied as the system information. However, the present invention is not limited to the example set forth herein. More specifically, regardless of the name, any protocol transmitting system information in a table format may be applied in the present invention.

[115] The PSI table is an MPEG-2 system standard defined for identifying the channels and the programs. The PSIP table is an advanced television systems committee (ATSC) standard that can identify the channels and the programs. The PSI table may include a program association table (PAT), a conditional access table (CAT), a program map table (PMT), and a network information table (NIT). Herein, the PAT corresponds to special information that is transmitted by a data packet having a PID of '0'. The PAT transmits PID information of the PMT and PID information of the NIT corresponding to each program. The CAT transmits information on a paid broadcast system used by the transmitting system. The PMT transmits PID information of a transport stream (TS) packet, in which program identification numbers and individual bit sequences of video and audio data configuring the corresponding program are transmitted, and the PID information, in which PCR is transmitted. The NIT transmits information of the actual transmission network.

- [116] The PSIP table may include a virtual channel table (VCT), a system time table (STT), a rating region table (RRT), an extended text table (ETT), a direct channel change table (DCCT), an event information table (EIT), and a master guide table (MGT). The VCT transmits information on virtual channels, such as channel information for selecting channels and information such as packet identification (PID) numbers for receiving the audio and/or video data. More specifically, when the VCT is parsed, the PID of the audio/video data of the broadcast program may be known. Herein, the corresponding audio/video data are transmitted within the channel along with the channel name and the channel number. The STT transmits information on the current data and timing information. The RRT transmits information on region and consultation organs for program ratings. The ETT transmits additional description of a specific channel and broadcast program. The EIT transmits information on virtual channel events (*e.g.*, program title, program start time, *etc.*). The DCCT/DCCSCT transmits information associated with automatic (or direct) channel change. And, the MGT transmits the versions and PID information of the above-mentioned tables included in the PSIP.
- [117] Each of the above-described tables included in the PSI/PSIP is configured of a basic unit referred to as a "section", and a combination of one or more sections forms a table. For example, the VCT may be divided into 256 sections. Herein, one section may include a plurality of virtual channel information. However, a single set of virtual channel information is not divided into two or more sections. At this point, the receiving system may parse and decode the data for the data service that are transmitting by using only the tables included in the PSI, or only the tables included in the PSIP, or a combination of tables included in both the PSI and the PSIP. In order to parse and decode the data for the data service, at least one of the PAT and PMT included in the PSI, and the VCT included in the PSIP is required. For example, the PAT may include the system information for transmitting the data corresponding to the data service, and the PID of the PMT corresponding to the data service data (or program number). The PMT may include the PID of the TS packet used for transmitting the data service data. The VCT may include information on the virtual channel for transmitting the data service data, and the PID of the TS packet for transmitting the data service data.
- [118] Meanwhile, depending upon the embodiment of the present invention, a DVB-SI may be applied instead of the PSIP. The DVB-SI may include a network information table (NIT), a service description table (SDT), an event information table (EIT), and a time and data table (TDT). The DVB-SI may be used in combination with the above-described PSI. Herein, the NIT divides the services corresponding to particular network providers by specific groups. The NIT includes all tuning information that are

used during the IRD set-up. The NIT may be used for informing or notifying any change in the tuning information. The SDT includes the service name and different parameters associated with each service corresponding to a particular MPEG multiplex. The EIT is used for transmitting information associated with all events occurring in the MPEG multiplex. The EIT includes information on the current transmission and also includes information selectively containing different transmission streams that may be received by the IRD. And, the TDT is used for updating the clock included in the IRD.

- [119] Furthermore, three selective SI tables (*i.e.*, a bouquet associate table (BAT), a running status table (RST), and a stuffing table (ST)) may also be included. More specifically, the bouquet associate table (BAT) provides a service grouping method enabling the IRD to provide services to the viewers. Each specific service may belong to at least one 'bouquet' unit. A running status table (RST) section is used for promptly and instantly updating at least one event execution status. The execution status section is transmitted only once at the changing point of the event status. Other SI tables are generally transmitted several times. The stuffing table (ST) may be used for replacing or discarding a subsidiary table or the entire SI tables.
- [120] In the present invention, the enhanced data included in the payload within the TS packet consist of a digital storage media-command and control (DSM-CC) section format. However, the TS packet including the data service data may correspond either to a packetized elementary stream (PES) type or to a section type. More specifically, either the PES type data service data configure the TS packet, or the section type data service data configure the TS packet. The TS packet configured of the section type data will be given as the example of the present invention. At this point, the data service data are includes in the digital storage media-command and control (DSM-CC) section. Herein, the DSM-CC section is then configured of a 188-byte unit TS packet.
- [121] Furthermore, the packet identification of the TS packet configuring the DSM-CC section is included in a data service table (DST). When transmitting the DST, '0x95' is assigned as the value of a stream\_type field included in the service location descriptor of the PMT or the VCT. More specifically, when the PMT or VCT stream\_type field value is '0x95', the receiving system may acknowledge that data broadcasting including enhanced data (*i.e.*, the enhanced data) is being received. At this point, the enhanced data may be transmitted by a data carousel method. The data carousel method corresponds to repeatedly transmitting identical data on a regular basis.
- [122] At this point, according to the control of the data decoder 1010, the demultiplexer 1003 performs section filtering, thereby discarding repetitive sections and outputting only the non-repetitive sections to the data decoder 1010. The demultiplexer 1003 may also output only the sections configuring desired tables (*e.g.*, VCT) to the data decoder

1010 by section filtering. Herein, the VCT may include a specific descriptor for the enhanced data. However, the present invention does not exclude the possibilities of the enhanced data being included in other tables, such as the PMT. The section filtering method may include a method of verifying the PID of a table defined by the MGT, such as the VCT, prior to performing the section filtering process. Alternatively, the section filtering method may also include a method of directly performing the section filtering process without verifying the MGT, when the VCT includes a fixed PID (*i.e.*, a base PID). At this point, the demultiplexer 1003 performs the section filtering process by referring to a table\_id field, a version\_number field, a section\_number field, *etc.*

[123] As described above, the method of defining the PID of the VCT broadly includes two different methods. Herein, the PID of the VCT is a packet identifier required for identifying the VCT from other tables. The first method consists of setting the PID of the VCT so that it is dependent to the MGT. In this case, the receiving system cannot directly verify the VCT among the many PSI and/or PSIP tables. Instead, the receiving system must check the PID defined in the MGT in order to read the VCT. Herein, the MGT defines the PID, size, version number, and so on, of diverse tables. The second method consists of setting the PID of the VCT so that the PID is given a base PID value (or a fixed PID value), thereby being independent from the MGT. In this case, unlike in the first method, the VCT according to the present invention may be identified without having to verify every single PID included in the MGT. Evidently, an agreement on the base PID must be previously made between the transmitting system and the receiving system.

[124] Meanwhile, in the embodiment of the present invention, the demultiplexer 1003 may output only an application information table (AIT) to the data decoder 1010 by section filtering. The AIT includes information on an application being operated in the receiving system for the data service. The AIT may also be referred to as an XAIT, and an AMT. Therefore, any table including application information may correspond to the following description. When the AIT is transmitted, a value of '0x05' may be assigned to a stream\_type field of the PMT. The AIT may include application information, such as application name, application version, application priority, application ID, application status (*i.e.*, auto-start, user-specific settings, kill, *etc.*), application type (*i.e.*, Java or HTML), position (or location) of stream including application class and data files, application platform directory, and location of application icon.

[125] In the method for detecting application information for the data service by using the AIT, component\_tag, original\_network\_id, transport\_stream\_id, and service\_id fields may be used for detecting the application information. The component\_tag field designates an elementary stream carrying a DSI of a corresponding object carousel.

The original\_network\_id field indicates a DVB-SI original\_network\_id of the TS providing transport connection. The transport\_stream\_id field indicates the MPEG TS of the TS providing transport connection, and the service\_id field indicates the DVB-SI of the service providing transport connection. Information on a specific channel may be obtained by using the original\_network\_id field, the transport\_stream\_id field, and the service\_id field. The data service data, such as the application data, detected by using the above-described method may be stored in the second memory 1011 by the data decoder 1010.

[126] The data decoder 1010 parses the DSM-CC section configuring the demultiplexed enhanced data. Then, the enhanced data corresponding to the parsed result are stored as a database in the second memory 1011. The data decoder 1010 groups a plurality of sections having the same table identification (table\_id) so as to configure a table, which is then parsed. Thereafter, the parsed result is stored as a database in the second memory 1011. At this point, by parsing data and/or sections, the data decoder 1010 reads all of the remaining actual section data that are not section-filtered by the demultiplexer 1003. Then, the data decoder 1010 stores the read data to the second memory 1011. The second memory 1011 corresponds to a table and data carousel database storing system information parsed from tables and enhanced data parsed from the DSM-CC section. Herein, a table\_id field, a section\_number field, and a last\_section\_number field included in the table may be used to indicate whether the corresponding table is configured of a single section or a plurality of sections. For example, TS packets having the PID of the VCT are grouped to form a section, and sections having table identifiers allocated to the VCT are grouped to form the VCT.

[127] When the VCT is parsed, information on the virtual channel to which enhanced data are transmitted may be obtained. The obtained application identification information, service component identification information, and service information corresponding to the data service may either be stored in the second memory 1011 or be outputted to the data broadcasting application manager 1013. In addition, reference may be made to the application identification information, service component identification information, and service information in order to decode the data service data. Alternatively, such information may also prepare the operation of the application program for the data service. Furthermore, the data decoder 1010 controls the demultiplexing of the system information table, which corresponds to the information table associated with the channel and events. Thereafter, an A.V PID list may be transmitted to the channel manager 1007.

[128] The channel manager 1007 may refer to the channel map 1008 in order to transmit a request for receiving system-related information data to the data decoder 1010, thereby receiving the corresponding result. In addition, the channel manager 1007 may also

control the channel tuning of the tuner 1001. Furthermore, the channel manager 1007 may directly control the demultiplexer 1003, so as to set up the A/V PID, thereby controlling the audio decoder 1004 and the video decoder 1005. The audio decoder 1004 and the video decoder 1005 may respectively decode and output the audio data and video data demultiplexed from the main data packet. Alternatively, the audio decoder 1004 and the video decoder 1005 may respectively decode and output the audio data and video data demultiplexed from the enhanced data packet. Meanwhile, when the enhanced data include data service data, and also audio data and video data, it is apparent that the audio data and video data demultiplexed by the demultiplexer 1003 are respectively decoded by the audio decoder 1004 and the video decoder 1005. For example, an audio-coding (AC)-3 decoding algorithm may be applied to the audio decoder 1004, and a MPEG-2 decoding algorithm may be applied to the video decoder 1005.

[129] Meanwhile, the native TV application manager 1006 operates a native application program stored in the first memory 1009, thereby performing general functions such as channel change. The native application program refers to software stored in the receiving system upon shipping of the product. More specifically, when a user request (or command) is transmitted to the receiving system through a user interface (UI), the native TV application manager 1006 displays the user request on a screen through a graphic user interface (GUI), thereby responding to the user's request. The user interface receives the user request through an input device, such as a remote controller, a key pad, a jog controller, an a touch-screen provided on the screen, and then outputs the received user request to the native TV application manager 1006 and the data broadcasting application manager 1013. Furthermore, the native TV application manager 1006 controls the channel manager 1007, thereby controlling channel-associated, such as the management of the channel map 1008, and controlling the data decoder 1010. The native TV application manager 1006 also controls the GUI of the overall receiving system, thereby storing the user request and status of the receiving system in the first memory 1009 and restoring the stored information.

[130] The channel manager 1007 controls the tuner 1001 and the data decoder 1010, so as to managing the channel map 1008 so that it can respond to the channel request made by the user. More specifically, channel manager 1007 sends a request to the data decoder 1010 so that the tables associated with the channels that are to be tuned are parsed. The results of the parsed tables are reported to the channel manager 1007 by the data decoder 1010. Thereafter, based on the parsed results, the channel manager 1007 updates the channel map 1008 and sets up a PID in the demultiplexer 1003 for demultiplexing the tables associated with the data service data from the enhanced data.

[131] The system manager 1012 controls the booting of the receiving system by turning

the power on or off. Then, the system manager 1012 stores ROM images (including downloaded software images) in the first memory 1009. More specifically, the first memory 1009 stores management programs such as operating system (OS) programs required for managing the receiving system and also application program executing data service functions. The application program is a program processing the data service data stored in the second memory 1011 so as to provide the user with the data service. If the data service data are stored in the second memory 1011, the corresponding data service data are processed by the above-described application program or by other application programs, thereby being provided to the user. The management program and application program stored in the first memory 1009 may be updated or corrected to a newly downloaded program. Furthermore, the storage of the stored management program and application program is maintained without being deleted even if the power of the system is shut down. Therefore, when the power is supplied the programs may be executed without having to be newly downloaded once again.

[132] The application program for providing data service according to the present invention may either be initially stored in the first memory 1009 upon the shipping of the receiving system, or be stored in the first 1009 after being downloaded. The application program for the data service (*i.e.*, the data service providing application program) stored in the first memory 1009 may also be deleted, updated, and corrected. Furthermore, the data service providing application program may be downloaded and executed along with the data service data each time the data service data are being received.

[133] When a data service request is transmitted through the user interface, the data broadcasting application manager 1013 operates the corresponding application program stored in the first memory 1009 so as to process the requested data, thereby providing the user with the requested data service. And, in order to provide such data service, the data broadcasting application manager 1013 supports the graphic user interface (GUI). Herein, the data service may be provided in the form of text (or short message service (SMS)), voice message, still image, and moving image. The data broadcasting application manager 1013 may be provided with a platform for executing the application program stored in the first memory 1009. The platform may be, for example, a Java virtual machine for executing the Java program. Hereinafter, an example of the data broadcasting application manager 1013 executing the data service providing application program stored in the first memory 1009, so as to process the data service data stored in the second memory 1011, thereby providing the user with the corresponding data service will now be described in detail.

[134] Assuming that the data service corresponds to a traffic information service, the data service according to the present invention is provided to the user of a receiving system

that is not equipped with an electronic map and/or a GPS system in the form of at least one of a text (or short message service (SMS)), a voice message, a graphic message, a still image, and a moving image. In this case, if a GPS module is mounted on the receiving system shown in FIG. 10, the GPS module receives satellite signals transmitted from a plurality of low earth orbit satellites and extracts the current position (or location) information (e.g., longitude, latitude, altitude), thereby outputting the extracted information to the data broadcasting application manager 1013.

[135] At this point, it is assumed that the electronic map including information on each link and node and other diverse graphic information are stored in one of the second memory 1011, the first memory 1009, and another memory that is not shown. More specifically, according to the request made by the data broadcasting application manager 1013, the data service data stored in the second memory 1011 are read and inputted to the data broadcasting application manager 1013. The data broadcasting application manager 1013 translates (or deciphers) the data service data read from the second memory 1011, thereby extracting the necessary information according to the contents of the message and/or a control signal.

[136] FIG. 11 illustrates a block diagram showing the structure of a digital broadcast (or television) receiving system according to another embodiment of the present invention. Referring to FIG. 11, the digital broadcast receiving system includes a tuner 2001, a demodulating unit 2002, a demultiplexer 2003, a first descrambler 2004, an audio decoder 2005, a video decoder 2006, a second descrambler 2007, an authentication unit 2008, a native TV application manager 2009, a channel manager 2010, a channel map 2011, a first memory 2012, a data decoder 2013, a second memory 2014, a system manager 2015, a data broadcasting application manager 2016, a storage controller 2017, a third memory 2018, and a telecommunication module 2019. Herein, the third memory 2018 is a mass storage device, such as a hard disk drive (HDD) or a memory chip. Also, during the description of the digital broadcast (or television or DTV) receiving system shown in FIG. 11, the components that are identical to those of the digital broadcast receiving system of FIG. 10 will be omitted for simplicity.

[137] As described above, in order to provide services for preventing illegal duplication (or copies) or illegal viewing of the enhanced data and/or main data that are transmitted by using a broadcast network, and to provide paid broadcast services, the transmitting system may generally scramble and transmit the broadcast contents. Therefore, the receiving system needs to descramble the scrambled broadcast contents in order to provide the user with the proper broadcast contents. Furthermore, the receiving system may generally be processed with an authentication process with an authentication means before the descrambling process. Hereinafter, the receiving system including an authentication means and a descrambling means according to an



embodiment of the present invention will now be described in detail.

[138] According to the present invention, the receiving system may be provided with a descrambling means receiving scrambled broadcasting contents and an authentication means authenticating (or verifying) whether the receiving system is entitled to receive the descrambled contents. Hereinafter, the descrambling means will be referred to as first and second descramblers 2004 and 2007, and the authentication means will be referred to as an authentication unit 2008. Such naming of the corresponding components is merely exemplary and is not limited to the terms suggested in the description of the present invention. For example, the units may also be referred to as a decryptor. Although FIG. 11 illustrates an example of the descramblers 2004 and 2007 and the authentication unit 2008 being provided inside the receiving system, each of the descramblers 2004 and 2007 and the authentication unit 2008 may also be separately provided in an internal or external module. Herein, the module may include a slot type, such as a SD or CF memory, a memory stick type, a USB type, and so on, and may be detachably fixed to the receiving system.

[139] As described above, when the authentication process is performed successfully by the authentication unit 2008, the scrambled broadcasting contents are descrambled by the descramblers 2004 and 2007, thereby being provided to the user. At this point, a variety of the authentication method and descrambling method may be used herein. However, an agreement on each corresponding method should be made between the receiving system and the transmitting system. Hereinafter, the authentication and descrambling methods will now be described, and the description of identical components or process steps will be omitted for simplicity.

[140] The receiving system including the authentication unit 2008 and the descramblers 2004 and 2007 will now be described in detail. The receiving system receives the scrambled broadcasting contents through the tuner 2001 and the demodulating unit 2002. Then, the system manager 2015 decides whether the received broadcasting contents have been scrambled. Herein, the demodulating unit 2002 may be included as a demodulating means according to embodiments of the present invention as described in FIG. 3 and FIG. 9. However, the present invention is not limited to the examples given in the description set forth herein. If the system manager 2015 decides that the received broadcasting contents have been scrambled, then the system manager 2015 controls the system to operate the authentication unit 2008. As described above, the authentication unit 2008 performs an authentication process in order to decide whether the receiving system according to the present invention corresponds to a legitimate host entitled to receive the paid broadcasting service. Herein, the authentication process may vary in accordance with the authentication methods.

[141] For example, the authentication unit 2008 may perform the authentication process

by comparing an IP address of an IP datagram within the received broadcasting contents with a specific address of a corresponding host. At this point, the specific address of the corresponding receiving system (or host) may be a MAC address. More specifically, the authentication unit 2008 may extract the IP address from the de-capsulated IP datagram, thereby obtaining the receiving system information that is mapped with the IP address. At this point, the receiving system should be provided, in advance, with information (*e.g.*, a table format) that can map the IP address and the receiving system information. Accordingly, the authentication unit 2008 performs the authentication process by determining the conformity between the address of the corresponding receiving system and the system information of the receiving system that is mapped with the IP address. In other words, if the authentication unit 2008 determines that the two types of information conform to one another, then the authentication unit 2008 determines that the receiving system is entitled to receive the corresponding broadcasting contents.

[142] In another example, standardized identification information is defined in advance by the receiving system and the transmitting system. Then, the identification information of the receiving system requesting the paid broadcasting service is transmitted by the transmitting system. Thereafter, the receiving system determines whether the received identification information conforms with its own unique identification number, so as to perform the authentication process. More specifically, the transmitting system creates a database for storing the identification information (or number) of the receiving system requesting the paid broadcasting service. Then, if the corresponding broadcasting contents are scrambled, the transmitting system includes the identification information in the EMM, which is then transmitted to the receiving system.

[143] If the corresponding broadcasting contents are scrambled, messages (*e.g.*, entitlement control message (ECM), entitlement management message (EMM)), such as the CAS information, mode information, message position information, that are applied to the scrambling of the broadcasting contents are transmitted through a corresponding data header or another data packet. The ECM may include a control word (CW) used for scrambling the broadcasting contents. At this point, the control word may be encoded with an authentication key. The EMM may include an authentication key and entitlement information of the corresponding data. Herein, the authentication key may be encoded with a receiver-specific distribution key. In other words, assuming that the enhanced data are scrambled by using the control word, and that the authentication information and the descrambling information are transmitted from the transmitting system, the transmitting system encodes the CW with the authentication key and, then, includes the encoded CW in the entitlement control message (ECM),

which is then transmitted to the receiving system. Furthermore, the transmitting system includes the authentication key used for encoding the CW and the entitlement to receive data (or services) of the receiving system (*i.e.*, a standardized serial number of the receiving system that is entitled to receive the corresponding broadcasting service or data) in the entitlement management message (EMM), which is then transmitted to the receiving system.

[144] Accordingly, the authentication unit 2008 of the receiving system extracts the identification information of the receiving system and the identification information included in the EMM of the broadcasting service that is being received. Then, the authentication unit 2008 determines whether the identification information conform to each other, so as to perform the authentication process. More specifically, if the authentication unit 2008 determines that the information conform to each other, then the authentication unit 2008 eventually determines that the receiving system is entitled to receive the request broadcasting service.

[145] In yet another example, the authentication unit 2008 of the receiving system may be detachably fixed to an external module. In this case, the receiving system is interfaced with the external module through a common interface (CI). In other words, the external module may receive the data scrambled by the receiving system through the common interface, thereby performing the descrambling process of the received data. Alternatively, the external module may also transmit only the information required for the descrambling process to the receiving system. The common interface is configured on a physical layer and at least one protocol layer. Herein, in consideration of any possible expansion of the protocol layer in a later process, the corresponding protocol layer may be configured to have at least one layer that can each provide an independent function.

[146] The external module may either consist of a memory or card having information on the key used for the scrambling process and other authentication information but not including any descrambling function, or consist of a card having the above-mentioned key information and authentication information and including the descrambling function. Both the receiving system and the external module should be authenticated in order to provide the user with the paid broadcasting service provided (or transmitted) from the transmitting system. Therefore, the transmitting system can only provide the corresponding paid broadcasting service to the authenticated pair of receiving system and external module.

[147] Additionally, an authentication process should also be performed between the receiving system and the external module through the common interface. More specifically, the module may communicate with the system manager 2015 included in the receiving system through the common interface, thereby authenticating the

receiving system. Alternatively, the receiving system may authenticate the module through the common interface. Furthermore, during the authentication process, the module may extract the unique ID of the receiving system and its own unique ID and transmit the extracted IDs to the transmitting system. Thus, the transmitting system may use the transmitted ID values as information determining whether to start the requested service or as payment information. Whenever necessary, the system manager 2015 transmits the payment information to the remote transmitting system through the telecommunication module 2019.

[148] The authentication unit 2008 authenticates the corresponding receiving system and/or the external module. Then, if the authentication process is successfully completed, the authentication unit 2008 certifies the corresponding receiving system and/or the external module as a legitimate system and/or module entitled to receive the requested paid broadcasting service. In addition, the authentication unit 2008 may also receive authentication-associated information from a mobile telecommunications service provider to which the user of the receiving system is subscribed, instead of the transmitting system providing the requested broadcasting service. In this case, the authentication-association information may either be scrambled by the transmitting system providing the broadcasting service and, then, transmitted to the user through the mobile telecommunications service provider, or be directly scrambled and transmitted by the mobile telecommunications service provider. Once the authentication process is successfully completed by the authentication unit 2008, the receiving system may descramble the scrambled broadcasting contents received from the transmitting system. At this point, the descrambling process is performed by the first and second descramblers 2004 and 2007. Herein, the first and second descramblers 2004 and 2007 may be included in an internal module or an external module of the receiving system.

[149] The receiving system is also provided with a common interface for communicating with the external module including the first and second descramblers 2004 and 2007, so as to perform the descrambling process. More specifically, the first and second descramblers 2004 and 2007 may be included in the module or in the receiving system in the form of hardware, middleware or software. Herein, the descramblers 2004 and 2007 may be included in any one of or both of the module and the receiving system. If the first and second descramblers 2004 and 2007 are provided inside the receiving system, it is advantageous to have the transmitting system (*i.e.*, at least any one of a service provider and a broadcast station) scramble the corresponding data using the same scrambling method.

[150] Alternatively, if the first and second descramblers 2004 and 2007 are provided in the external module, it is advantageous to have each transmitting system scramble the corresponding data using different scrambling methods. In this case, the receiving

system is not required to be provided with the descrambling algorithm corresponding to each transmitting system. Therefore, the structure and size of receiving system may be simplified and more compact. Accordingly, in this case, the external module itself may be able to provide CA functions, which are uniquely and only provided by each transmitting systems, and functions related to each service that is to be provided to the user. The common interface enables the various external modules and the system manager 2015, which is included in the receiving system, to communicate with one another by a single communication method. Furthermore, since the receiving system may be operated by being connected with at least one or more modules providing different services, the receiving system may be connected to a plurality of modules and controllers.

[151] In order to maintain successful communication between the receiving system and the external module, the common interface protocol includes a function of periodically checking the status of the opposite correspondent. By using this function, the receiving system and the external module is capable of managing the status of each opposite correspondent. This function also reports the user or the transmitting system of any malfunction that may occur in any one of the receiving system and the external module and attempts the recovery of the malfunction.

[152] In yet another example, the authentication process may be performed through software. More specifically, when a memory card having CAS software downloaded, for example, and stored therein in advanced is inserted in the receiving system, the receiving system receives and loads the CAS software from the memory card so as to perform the authentication process. In this example, the CAS software is read out from the memory card and stored in the first memory 2012 of the receiving system. Thereafter, the CAS software is operated in the receiving system as an application program. According to an embodiment of the present invention, the CAS software is mounted on (or stored) in a middleware platform and, then executed. A Java middleware will be given as an example of the middleware included in the present invention. Herein, the CAS software should at least include information required for the authentication process and also information required for the descrambling process.

[153] Therefore, the authentication unit 2008 performs authentication processes between the transmitting system and the receiving system and also between the receiving system and the memory card. At this point, as described above, the memory card should be entitled to receive the corresponding data and should include information on a normal receiving system that can be authenticated. For example, information on the receiving system may include a unique number, such as a standardized serial number of the corresponding receiving system. Accordingly, the authentication unit 2008 compares the standardized serial number included in the memory card with the unique

information of the receiving system, thereby performing the authentication process between the receiving system and the memory card.

[154] If the CAS software is first executed in the Java middleware base, then the authentication between the receiving system and the memory card is performed. For example, when the unique number of the receiving system stored in the memory card conforms to the unique number of the receiving system read from the system manager 2015, then the memory card is verified and determined to be a normal memory card that may be used in the receiving system. At this point, the CAS software may either be installed in the first memory 2012 upon the shipping of the present invention, or be downloaded to the first memory 2012 from the transmitting system or the module or memory card, as described above. Herein, the descrambling function may be operated by the data broadcasting application manger 2016 as an application program.

[155] Thereafter, the CAS software parses the EMM/ECM packets outputted from the demultiplexer 2003, so as to verify whether the receiving system is entitled to receive the corresponding data, thereby obtaining the information required for descrambling (*i.e.*, the CW) and providing the obtained CW to the descramblers 2004 and 2007. More specifically, the CAS software operating in the Java middleware platform first reads out the unique (or serial) number of the receiving system from the corresponding receiving system and compares it with the unique number of the receiving system transmitted through the EMM, thereby verifying whether the receiving system is entitled to receive the corresponding data. Once the receiving entitlement of the receiving system is verified, the corresponding broadcasting service information transmitted to the ECM and the entitlement of receiving the corresponding broadcasting service are used to verify whether the receiving system is entitled to receive the corresponding broadcasting service. Once the receiving system is verified to be entitled to receive the corresponding broadcasting service, the authentication key transmitted to the EMM is used to decode (or decipher) the encoded CW, which is transmitted to the ECM, thereby transmitting the decoded CW to the descramblers 2004 and 2007. Each of the descramblers 2004 and 2007 uses the CW to descramble the broadcasting service.

[156] Meanwhile, the CAS software stored in the memory card may be expanded in accordance with the paid service which the broadcast station is to provide. Additionally, the CAS software may also include other additional information other than the information associated with the authentication and descrambling. Furthermore, the receiving system may download the CAS software from the transmitting system so as to upgrade (or update) the CAS software originally stored in the memory card. As described above, regardless of the type of broadcast receiving system, as long as an external memory interface is provided, the present invention may embody a CAS

system that can meet the requirements of all types of memory card that may be detachably fixed to the receiving system. Thus, the present invention may realize maximum performance of the receiving system with minimum fabrication cost, wherein the receiving system may receive paid broadcasting contents such as broadcast programs, thereby acknowledging and regarding the variety of the receiving system. Moreover, since only the minimum application program interface is required to be embodied in the embodiment of the present invention, the fabrication cost may be minimized, thereby eliminating the manufacturer's dependence on CAS manufacturers. Accordingly, fabrication costs of CAS equipments and management systems may also be minimized.

[157] Meanwhile, the descramblers 2004 and 2007 may be included in the module either in the form of hardware or in the form of software. In this case, the scrambled data that being received are descrambled by the module and then demodulated. Also, if the scrambled data that are being received are stored in the third memory 2018, the received data may be descrambled and then stored, or stored in the memory at the point of being received and then descrambled later on prior to being played (or reproduced). Thereafter, in case scramble/descramble algorithms are provided in the storage controller 2017, the storage controller 2017 scrambles the data that are being received once again and then stores the re-scrambled data to the third memory 2018.

[158] In yet another example, the descrambled broadcasting contents (transmission of which being restricted) are transmitted through the broadcasting network. Also, information associated with the authentication and descrambling of data in order to disable the receiving restrictions of the corresponding data are transmitted and/or received through the telecommunications module 2019. Thus, the receiving system is able to perform reciprocal (or two-way) communication. The receiving system may either transmit data to the telecommunication module within the transmitting system or be provided with the data from the telecommunication module within the transmitting system. Herein, the data correspond to broadcasting data that are desired to be transmitted to or from the transmitting system, and also unique information (*i.e.*, identification information) such as a serial number of the receiving system or MAC address.

[159] The telecommunication module 2019 included in the receiving system provides a protocol required for performing reciprocal (or two-way) communication between the receiving system, which does not support the reciprocal communication function, and the telecommunication module included in the transmitting system. Furthermore, the receiving system configures a protocol data unit (PDU) using a tag-length-value (TLV) coding method including the data that are to be transmitted and the unique information (or ID information). Herein, the tag field includes indexing of the corresponding PDU.

The length field includes the length of the value field. And, the value field includes the actual data that are to be transmitted and the unique number (*e.g.*, identification number) of the receiving system.

[160] The receiving system may configure a platform that is equipped with the Java platform and that is operated after downloading the Java application of the transmitting system to the receiving system through the network. In this case, a structure of downloading the PDU including the tag field arbitrarily defined by the transmitting system from a storage means included in the receiving system and then transmitting the downloaded PDU to the telecommunication module 2019 may also be configured. Also, the PDU may be configured in the Java application of the receiving system and then outputted to the telecommunication module 2019. The PDU may also be configured by transmitting the tag value, the actual data that are to be transmitted, the unique information of the corresponding receiving system from the Java application and by performing the TLV coding process in the receiving system. This structure is advantageous in that the firmware of the receiving system is not required to be changed even if the data (or application) desired by the transmitting system is added.

[161] The telecommunication module within the transmitting system either transmits the PDU received from the receiving system through a wireless data network or configures the data received through the network into a PDU which is transmitted to the host. At this point, when configuring the PDU that is to be transmitted to the host, the telecommunication module within the transmitting end may include unique information (*e.g.*, IP address) of the transmitting system which is located in a remote location. Additionally, in receiving and transmitting data through the wireless data network, the receiving system may be provided with a common interface, and also provided with a WAP, CDMA 1x EV-DO, which can be connected through a mobile telecommunication base station, such as CDMA and GSM, and also provided with a wireless LAN, mobile internet, WiBro, WiMax, which can be connected through an access point. The above-described receiving system corresponds to the system that is not equipped with a telecommunication function. However, a receiving system equipped with telecommunication function does not require the telecommunication module 2019.

[162] The broadcasting data being transmitted and received through the above-described wireless data network may include data required for performing the function of limiting data reception. Meanwhile, the demultiplexer 2003 receives either the real-time data outputted from the demodulating unit 2002 or the data read from the third memory 2018, thereby performing demultiplexing. In this embodiment of the present invention, the demultiplexer 2003 performs demultiplexing on the enhanced data packet. Similar process steps have already been described earlier in the description of



the present invention. Therefore, a detailed of the process of demultiplexing the enhanced data will be omitted for simplicity.

[163] The first descrambler 2004 receives the demultiplexed signals from the demultiplexer 2003 and then descrambles the received signals. At this point, the first descrambler 2004 may receive the authentication result received from the authentication unit 2008 and other data required for the descrambling process, so as to perform the descrambling process. The audio decoder 2005 and the video decoder 2006 receive the signals descrambled by the first descrambler 2004, which are then decoded and outputted. Alternatively, if the first descrambler 2004 did not perform the descrambling process, then the audio decoder 2005 and the video decoder 2006 directly decode and output the received signals. In this case, the decoded signals are received and then descrambled by the second descrambler 2007 and processed accordingly.

[164] It will be apparent to those skilled in the art that various modifications and variations can be made in the present invention without departing from the spirit or scope of the inventions. Thus, it is intended that the present invention covers the modifications and variations of this invention provided they come within the scope of the appended claims and their equivalents.

## Claims

- [1] A digital broadcast receiving system, comprising:  
a demodulator tuning and receiving known data, when the known data having a specific pattern are periodically inserted in valid data, estimating a frequency offset from a signal received based upon known data information, and compensating the estimated offset frequency;  
a known data detector and coarse frequency offset detector detecting known data information inserted by a transmitting system and a coarse frequency offset from the signal prior to or after being demodulated; and  
a channel equalizer using the known data information detected from the known data detector and coarse frequency offset detector so as to compensate a channel distortion included in output data of the demodulator.
- [2] The digital broadcast receiving system of claim 1, wherein the demodulator comprises:  
a multiplier multiplying an input signal with a complex signal so as to compensate the frequency offset;  
a fine frequency offset estimator estimating a fine frequency offset from an output of the multiplier based upon the known data information outputted from the known data detector and coarse frequency offset detector;  
a select unit initially selecting a coarse frequency offset estimation value outputted from the known data detector and coarse frequency offset detector, and subsequently selecting a fine frequency offset estimation value outputted from the fine frequency offset estimator; and  
a compensation signal output unit generating a compensation frequency corresponding to the frequency offset being outputted from the select unit, and outputting a complex signal corresponding to the generated compensation frequency to the multiplier.
- [3] The digital broadcast receiving system of claim 2, further comprising:  
a loop filter filtering the fine frequency offset of the fine frequency offset estimator,  
wherein, in a detection mode, the select unit selects an output of the loop filter and outputs the selected output to the compensation signal output unit.
- [4] The digital broadcast receiving system of claim 2, wherein the fine frequency offset estimator comprises:  
a first N symbol buffer temporarily storing an input symbol;  
a K symbol delay delaying the input symbol by K number of symbols;  
a second N symbol buffer temporarily storing an output of the K symbol delay;

a conjugator performing complex conjugate multiplication of data outputted from the first N symbol buffer and the second N symbol buffer; and  
a phase detector accumulating the output of the conjugator for a period of N number of symbols so as to extract phase information, and outputting the extracted phase information as the fine frequency offset.

- [5] The digital broadcast receiving system of claim 4, wherein values N and K are diversely decided, and wherein, when a plurality of known data sequences having identical patterns is repeated in one known data section, N corresponds to B/2 and K corresponds to B/2 (wherein B represents a number of known data symbols).
- [6] The digital broadcast receiving system of claim 1, wherein the known data detector and coarse frequency offset detector comprises:  
a plurality of partial correlators receiving input signals that are oversampled to N times and decimating the input signals a rate of 1/N for each sampling phase, thereby performing partial correlation in each partial correlator; and  
the known data place detector and frequency offset decider storing each correlation value of the plurality of partial correlators during a pre-decided period, determining a highest value among the correlation values as a place for receiving the known data, deciding the frequency offset estimation value corresponding to the highest correlation value as the coarse frequency offset value, and outputting the decided coarse frequency offset value to the demodulator.
- [7] The digital broadcast receiving system of claim 6, wherein each of the partial correlators divides the known data, which are already known in accordance with an agreement between a transmitting system and a receiving system, having a length of L symbols to K number of portions, correlates each divided portion with a corresponding portion of the received signal, estimating a size information on the correlation value and a coarse frequency offset estimation value of a corresponding sampling phase, and outputting the estimated size information and value to the known data place detector and frequency offset decider.
- [8] The digital broadcast receiving system of claim 6, wherein each of the partial correlators comprises:  
K number of phase and size detectors dividing the known data, which are already known in accordance with an agreement between a transmitting system and a receiving system, having a length of L symbols to K number of portions, and correlating each divided portion with a corresponding portion of the received signal;  
an accumulator adding all correlation value sizes of the K number of phase and size detectors, and outputting the added value to the known data place detector

and frequency offset decider; and  
 a coarse frequency offset estimator estimating a coarse frequency offset from a phase of the correlation value of the K number of phase and size detectors, and outputting the estimated offset to the known data place detector and frequency offset decider.

- [9] The digital broadcast receiving system of claim 8, wherein the coarse frequency offset estimator estimates the coarse frequency offset by applying the equation below, wherein the K number of inputs are each referred to as  $\{Z_0, Z_1, \dots, Z_{K-1}\}$ :

$$m_0 = \frac{1}{L} \arg \left\{ \sum_{n=0}^{L-1} (Z_n \cdot Z_{n+1}^* \cdot \dots \cdot Z_{n+K-1}^*) \right\}$$

- [10] A data processing method of a digital broadcast receiving system, comprising:  
 a step of tuning and receiving known data, when the known data having a specific pattern are periodically inserted in valid data, oversampling the received known data to N times, and outputting the oversampled known data;  
 a step of receiving input signals that are oversampled to N times and decimating the input signals a rate of 1/N for each sampling phase, and performing partial correlation in each partial correlator, thereby detecting known data information and a coarse frequency offset;  
 a step of detecting a fine frequency offset from the received signal based upon the known data information; and  
 a step of initially using the coarse frequency offset estimation value, and subsequently using a fine frequency offset estimation value so as to compensate a frequency offset from the input signal.

- [11] The method of claim 10, wherein each partial correlation step in the step of detecting a coarse frequency offset divides the known data, which are already known in accordance with an agreement between a transmitting system and a receiving system, having a length of L symbols to K number of portions, and correlates each divided portion with a corresponding portion of the received signal

- [12] The method of claim 10, wherein the step of detecting a coarse frequency offset stores each correlation value of the plurality of partial correlators during a pre-decided period, determines a highest value among the correlation values as a place for receiving the known data, and decides the frequency offset estimation value corresponding to the highest correlation value as the coarse frequency offset value.

- [13] The method of claim 10, wherein the step of detecting a fine frequency offset comprises:  
 a step of performing complex conjugate multiplication of N number of input data

and N number of input data that are delayed by K number of symbols; and a step of accumulating the results of the step of performing multiplication so as to extract a phase value, and outputting the extracted phase value as the fine frequency offset.

[Fig. 1]

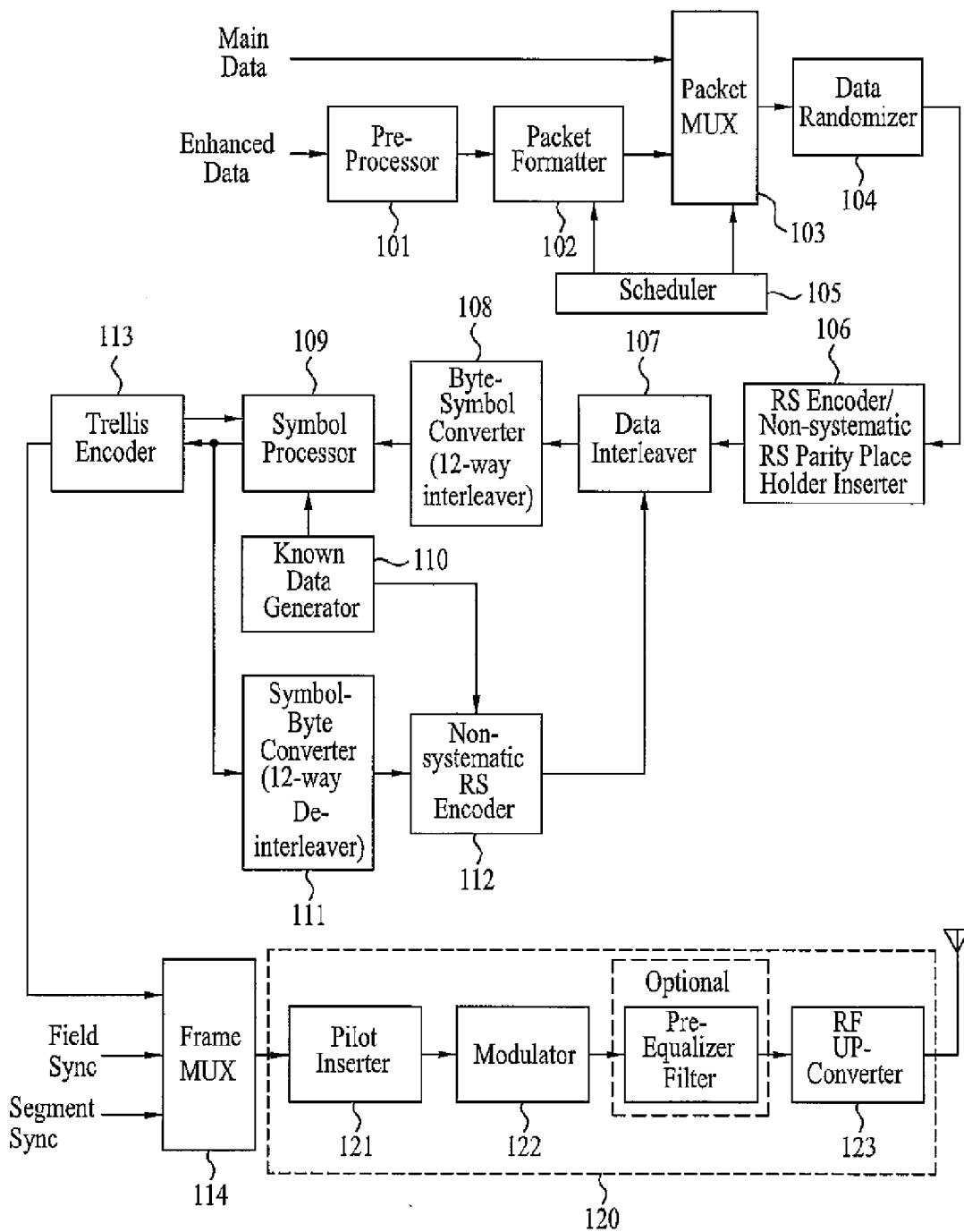

[Fig. 2]

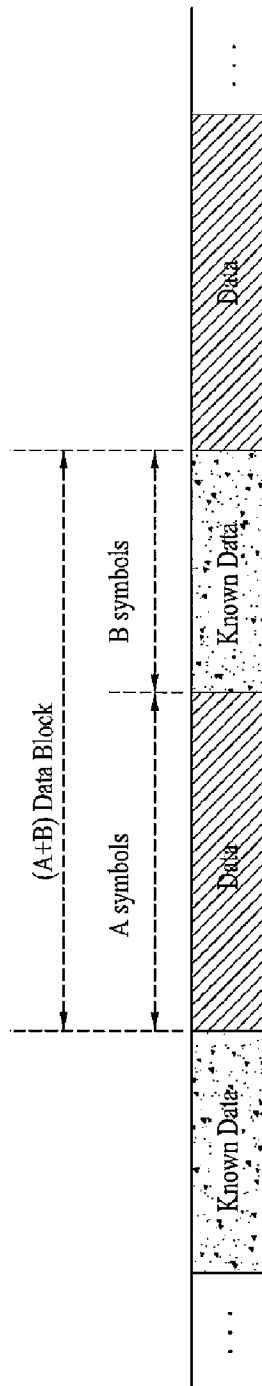

[Fig. 3]

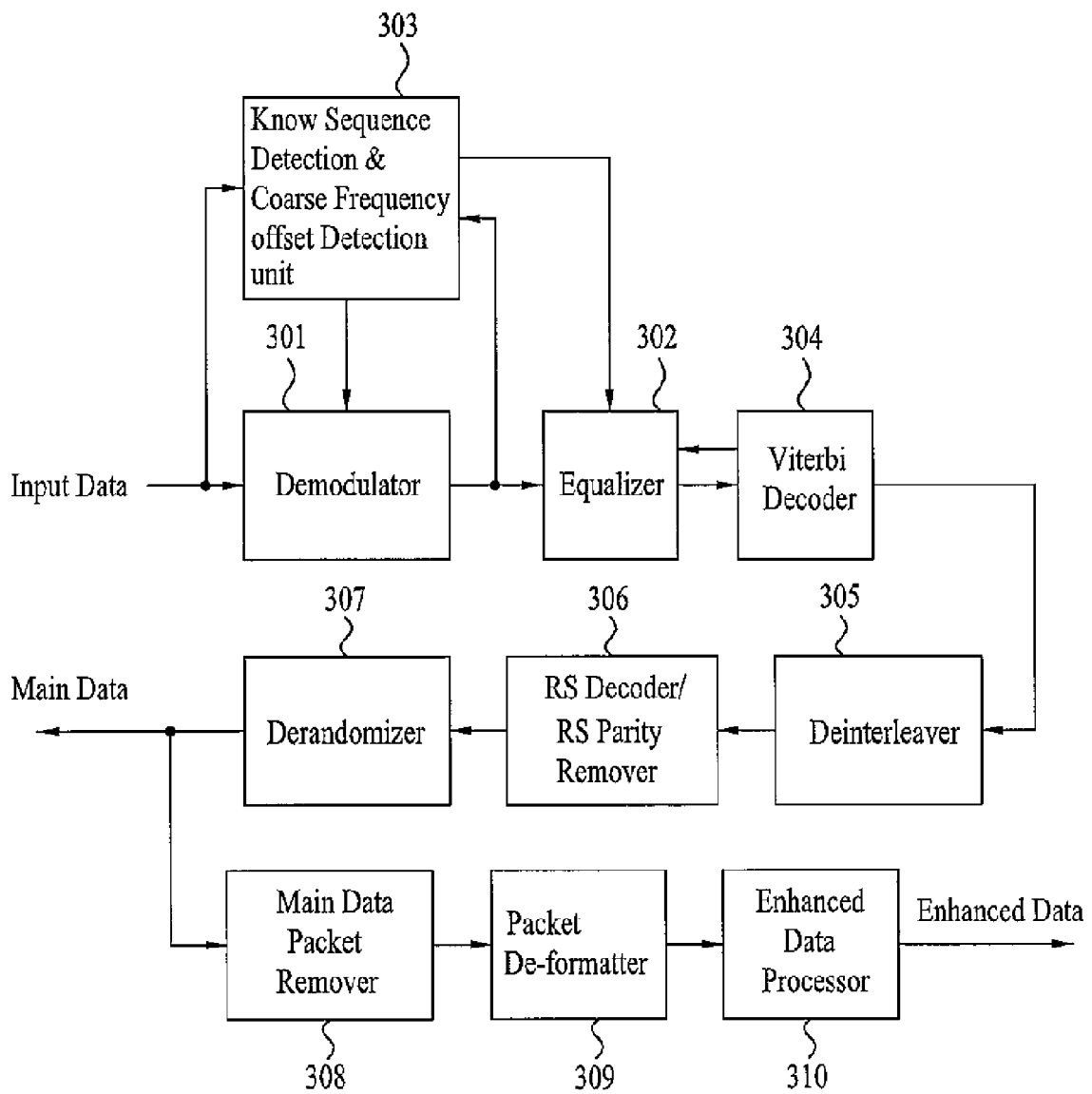



[Fig. 4]

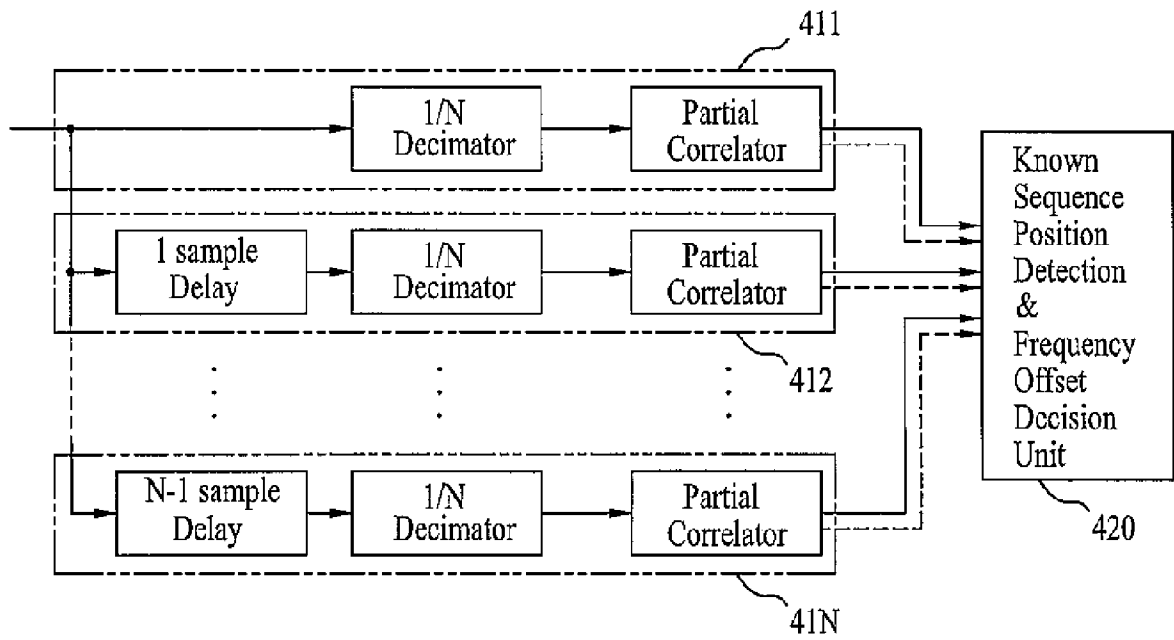

[Fig. 5]

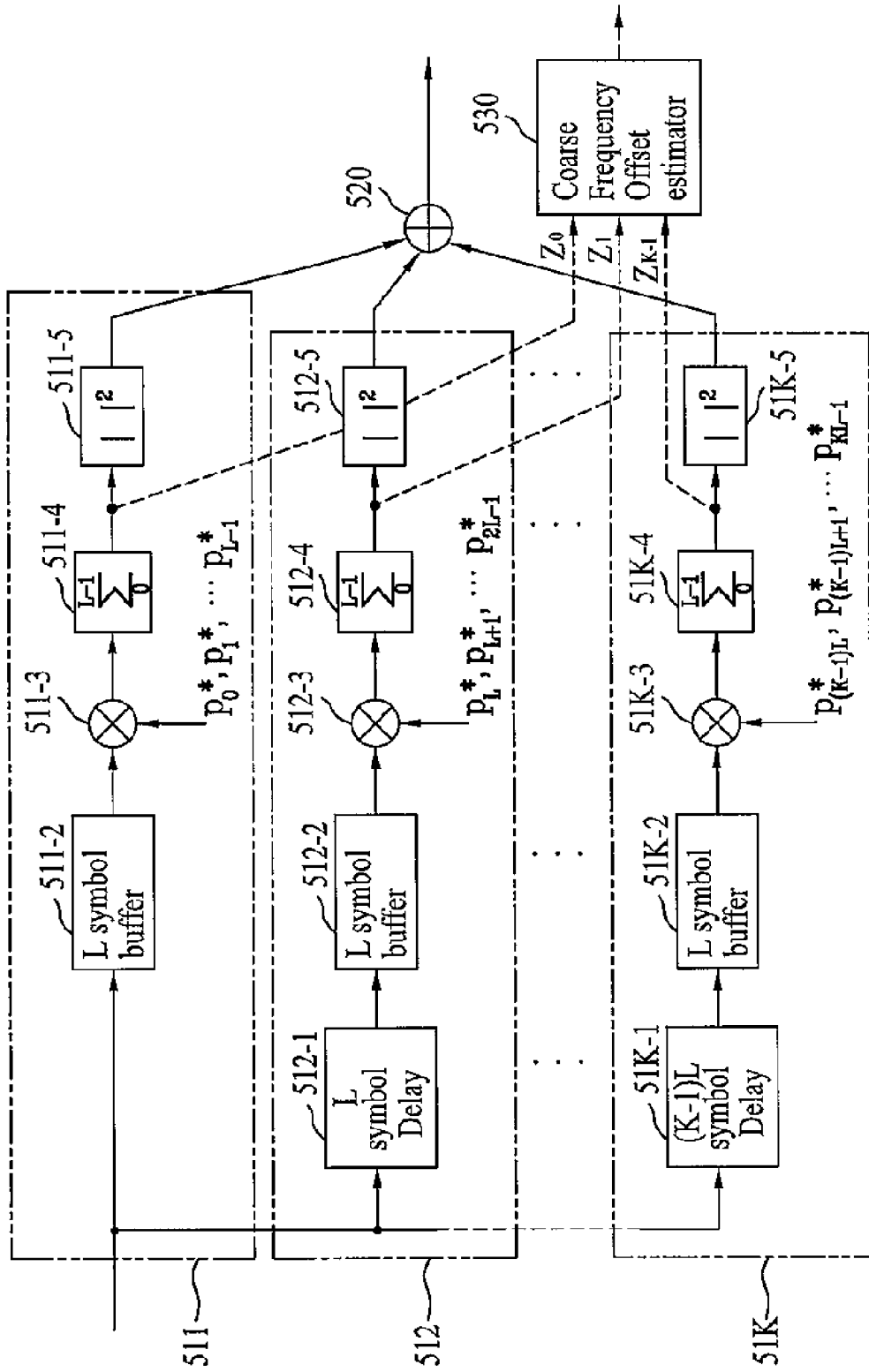

[Fig. 6]

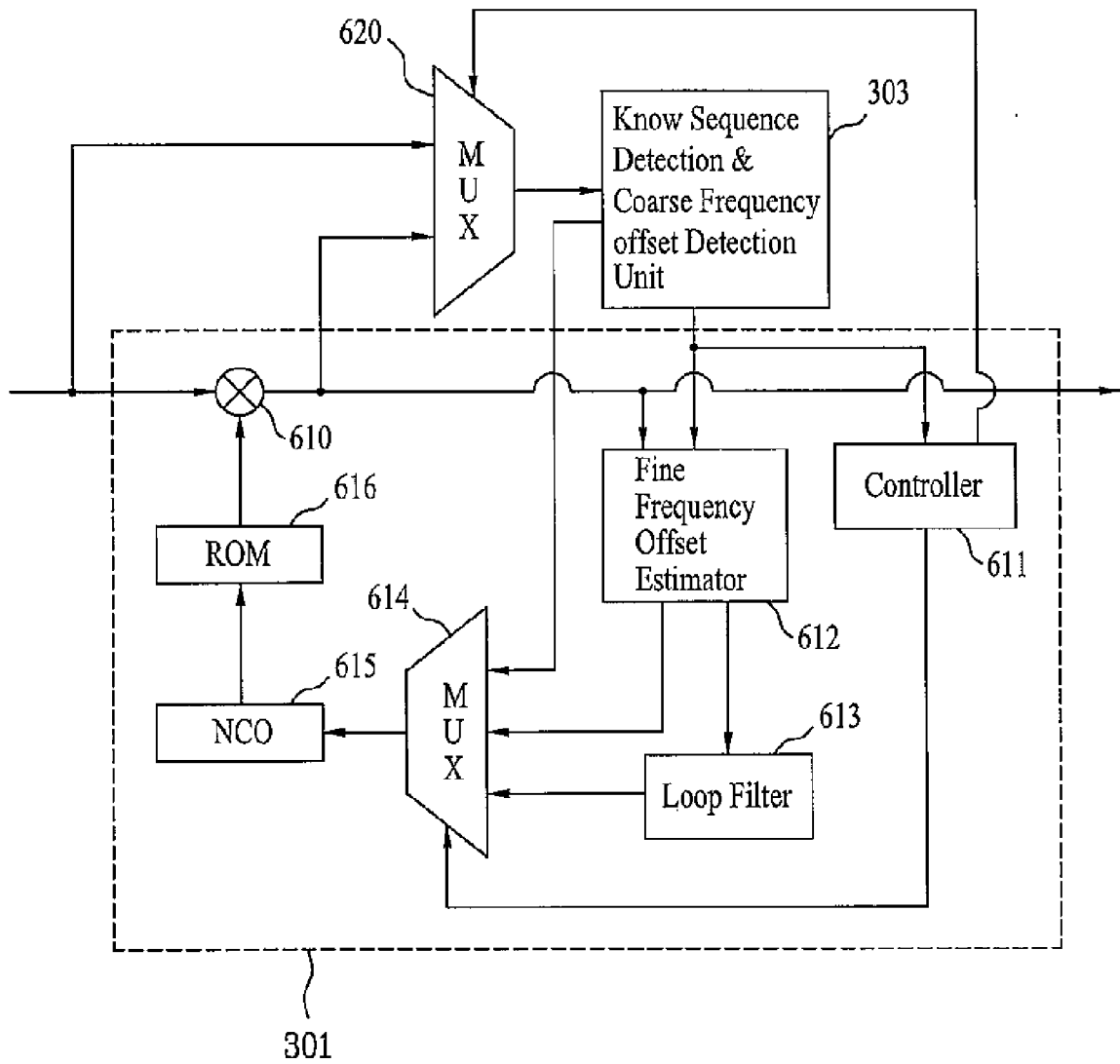

[Fig. 7]

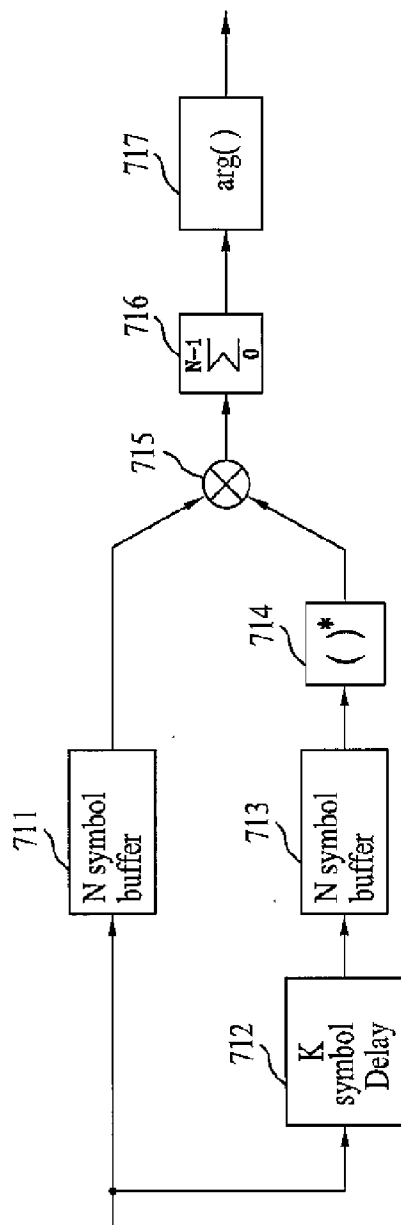

[Fig. 8]

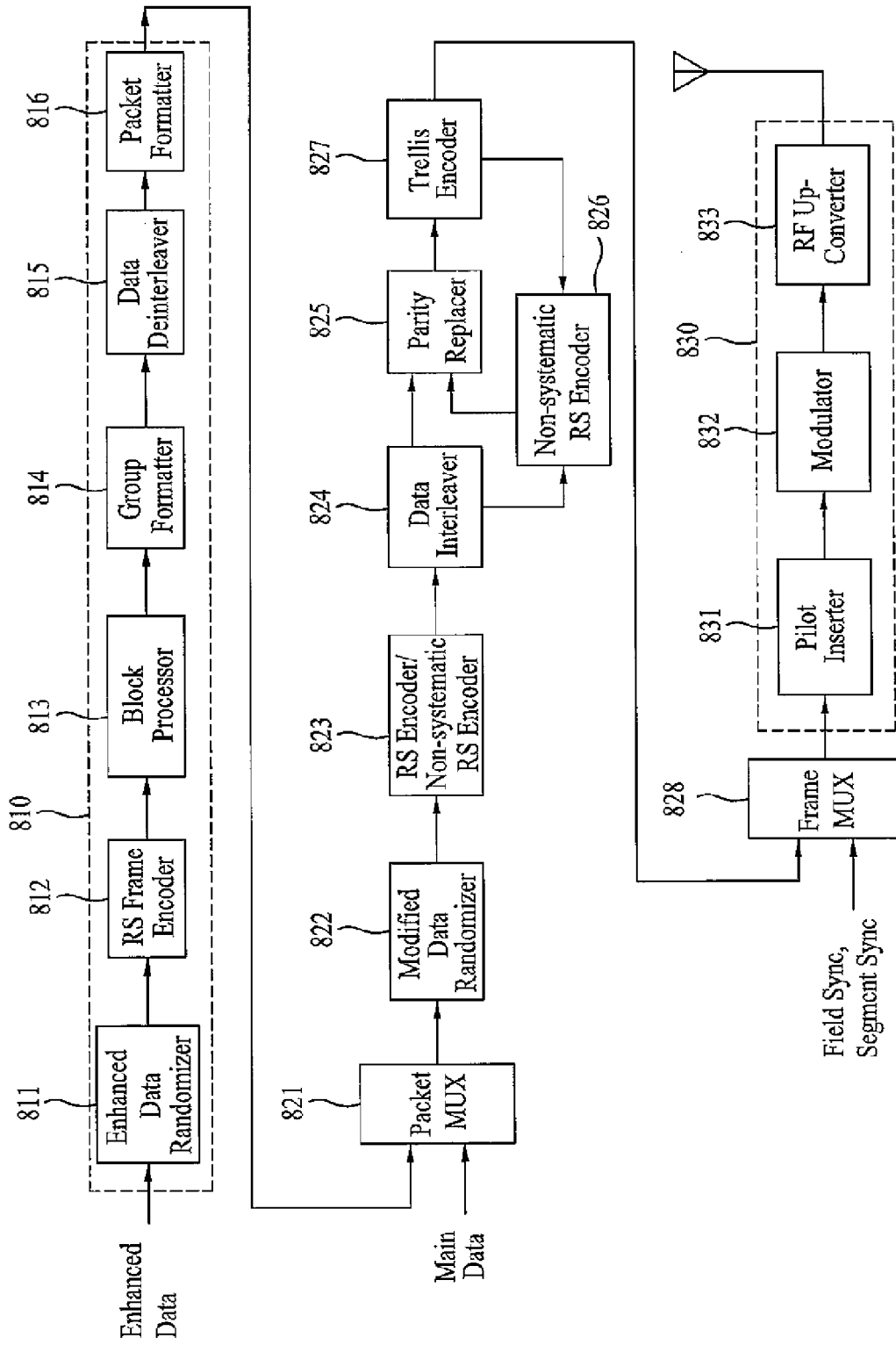

[Fig. 9]

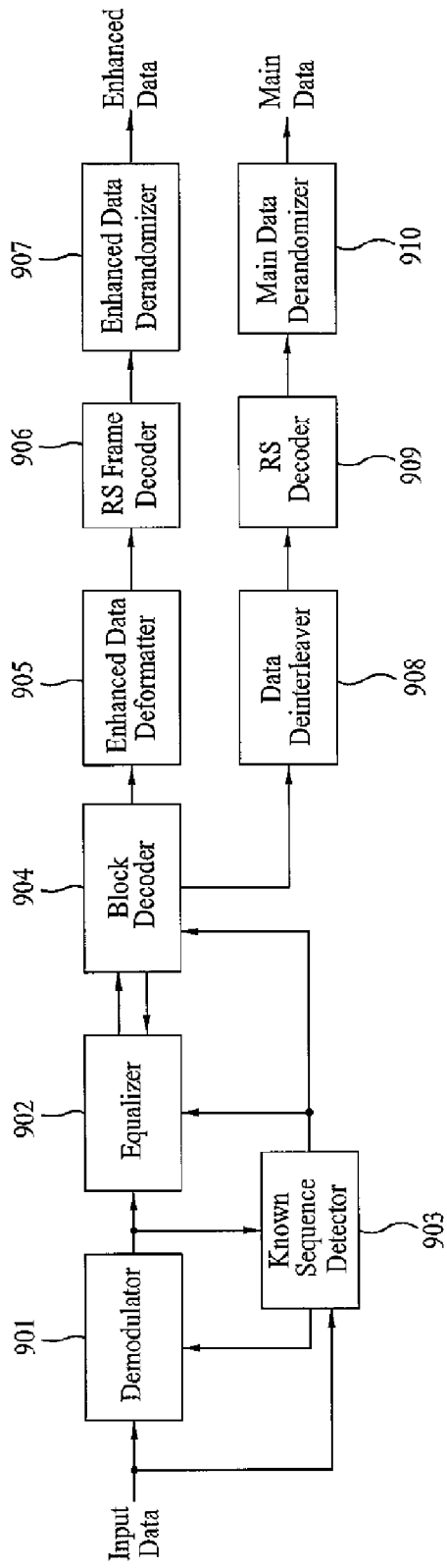

[Fig. 10]

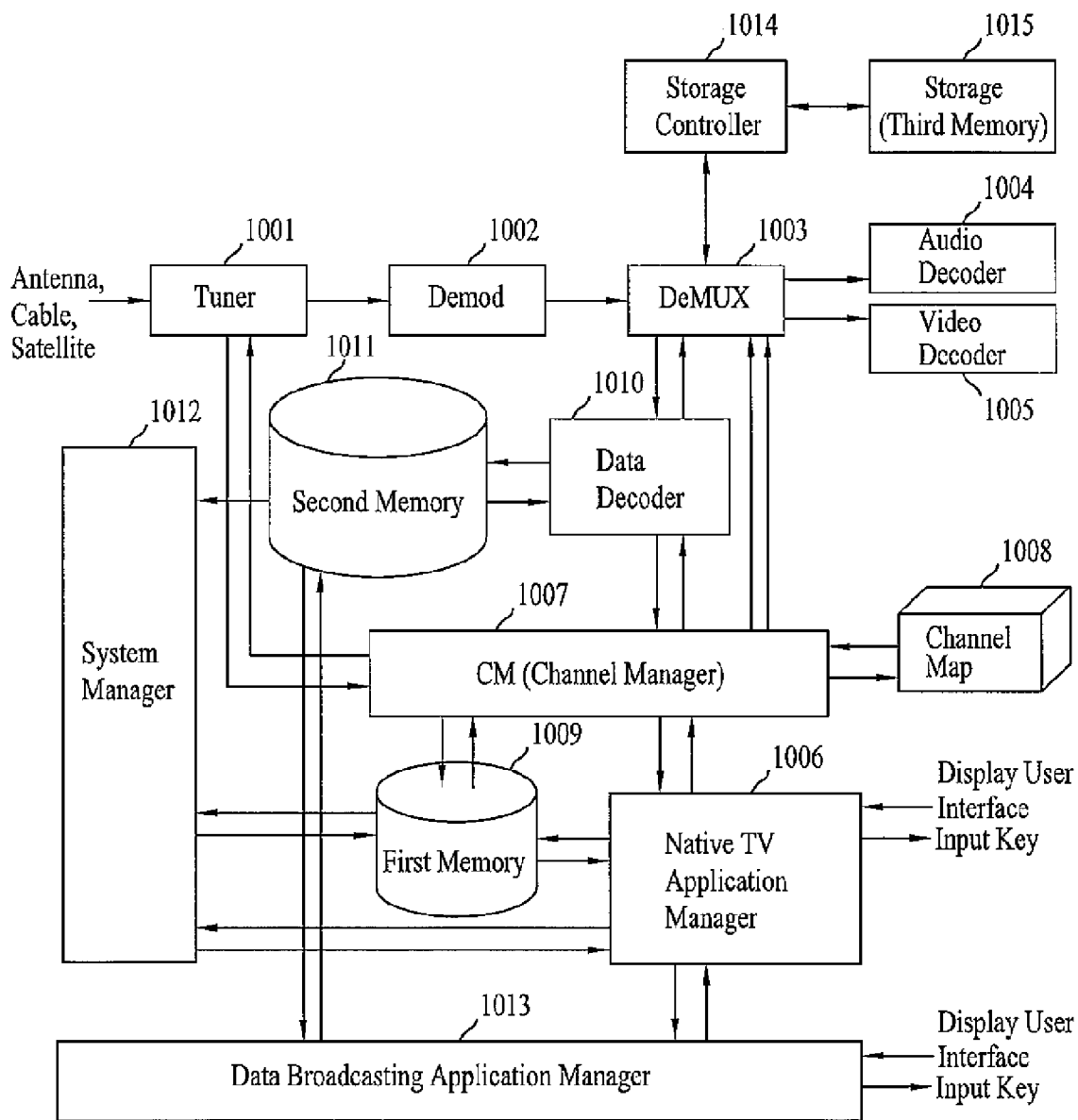

[Fig. 11]

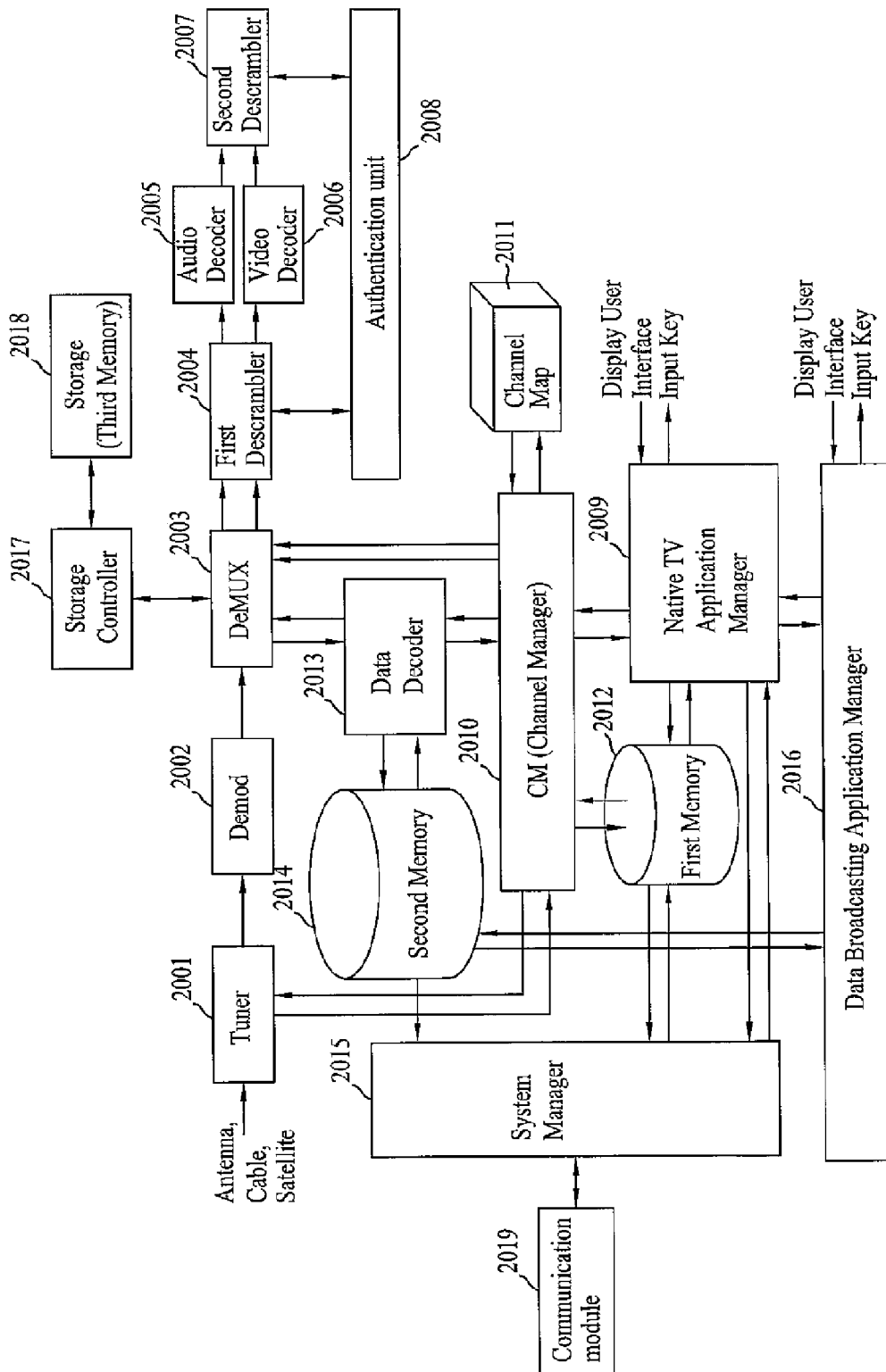



## INTERNATIONAL SEARCH REPORT

International application No.  
PCT/KR2006/005814**A. CLASSIFICATION OF SUBJECT MATTER****H04N 7/015(2006.01)i**

According to International Patent Classification (IPC) or to both national classification and IPC

**B. FIELDS SEARCHED**

Minimum documentation searched (classification system followed by classification symbols)

IPC 8 H04N

Documentation searched other than minimum documentation to the extent that such documents are included in the fields searched

Korean Utility models and applications for Utility models : IPC as above

Electronic data base consulted during the international search (name of data base and, where practicable, search terms used)

eKIPASS(KIPO internal) : "digital broadcast system", "demodulator", "channel equalizer"

**C. DOCUMENTS CONSIDERED TO BE RELEVANT**

Category*	Citation of document, with indication, where appropriate, of the relevant passages	Relevant to claim No.
A	US 2004/0125235 A1 (JOON TAE KIM ET AL) 1 Jul. 2004 See abstract.	1-13
A	US 6734920 B2 (MONISHA GHOSH ET AL) 11 May. 2004 See abstract; column 2, line 65 - column 6, line 10	1-13
A	US 2005/0175080 A1 (AARON REEL BOUILLETT) 11 Aug. 2005 See abstract	1-13

 Further documents are listed in the continuation of Box C. See patent family annex.

\* Special categories of cited documents:

"A" document defining the general state of the art which is not considered to be of particular relevance

"E" earlier application or patent but published on or after the international filing date

"L" document which may throw doubts on priority claim(s) or which is cited to establish the publication date of citation or other special reason (as specified)

"O" document referring to an oral disclosure, use, exhibition or other means

"P" document published prior to the international filing date but later than the priority date claimed

"T" later document published after the international filing date or priority date and not in conflict with the application but cited to understand the principle or theory underlying the invention

"X" document of particular relevance; the claimed invention cannot be considered novel or cannot be considered to involve an inventive step when the document is taken alone

"Y" document of particular relevance; the claimed invention cannot be considered to involve an inventive step when the document is combined with one or more other such documents, such combination being obvious to a person skilled in the art

"&amp;" document member of the same patent family

Date of the actual completion of the international search

03 APRIL 2007 (03.04.2007)

Date of mailing of the international search report

**04 APRIL 2007 (04.04.2007)**

Name and mailing address of the ISA/KR

Korean Intellectual Property Office  
920 Dunsan-dong, Seo-gu, Daejeon 302-701,  
Republic of Korea

Facsimile No. 82-42-472-7140

Authorized officer

KU, Dae Sung

Telephone No. 82-42-481-8192



**INTERNATIONAL SEARCH REPORT**

Information on patent family members

International application No.

PCT/KR2006/005814

Patent document cited in search report	Publication date	Patent family member(s)	Publication date
US20040125235A1	01.07.2004	KR2004053412A	24.06.2004
		US07151573	19.12.2006
		US2004125235A1	01.07.2004
		US2004125235AA	01.07.2004
		US7151573BB	19.12.2006
US06734920	11.05.2004	CN1463525A	24.12.2003
		EP01386459A1	04.02.2004
		EP1386459A1	04.02.2004
		JP16534440	11.11.2004
		JP2004534440T2	11.11.2004
		KR1020030014725	19.02.2003
		US20020154247A1	24.10.2002
		US2002154247A1	24.10.2002
		US2002154247AA	24.10.2002
		US6734920BB	11.05.2004
		W002087180A1	31.10.2002
W02002087180A1	31.10.2002		
US20050175080A1	11.08.2005	AU2003221849AA	03.11.2003
		AU2004282205AA	28.04.2005
		BR200309217A	09.02.2005
		CN1882521A	20.12.2006
		EP01680388A1	19.07.2006
		EP1495537A1	12.01.2005
		EP1680388A1	19.07.2006
		JP17523634	04.08.2005
		JP2005523634T2	04.08.2005
		KR1020040102096	03.12.2004
		MXPA04010248A	03.02.2005
		MXPA06004113A	05.07.2006
		US2005175080AA	11.08.2005
		W02003090349A1	30.10.2003
W02005037753A1	28.04.2005		