

(21) Application No 9021934.6

(22) Date of filing 09.10.1990

(71) Applicant
Biomet Limited

(Incorporated in the United Kingdom)

Waterton Industrial Estate, Bridgend,
South Glamorgan, CF31 3YN, United Kingdom

(72) Inventor
Ronald Bateman

(74) Agent and/or Address for Service
Haseltine Lake & Co
Hazlitt House, 28 Southampton Buildings,
Chancery Lane, London, WC2A 1AT, United Kingdom

(51) INT CL⁵
A61F 2/08

(52) UK CL (Edition K)
A5R RAM
F2H HV H15D H15F
U1S S1033

(56) Documents cited
EP 0279129 A EP 0238223 A

(58) Field of search
UK CL (Edition K) A5R RAM RAP
INT CL⁵ A61F

(54) Ligament fixator

(57) A fixator for securing a natural or synthetic ligament to a bone comprises a base plate 2 provided on one side with a pillar 4 extending generally perpendicularly therefrom and including a longitudinal passage which extends through the pillar and the plate to define a bore 8 for a bone screw, said base plate also including, on the same side as the pillar and also extending generally perpendicularly to the plate, a series of projections 6 capable of penetrating said ligament and bone.

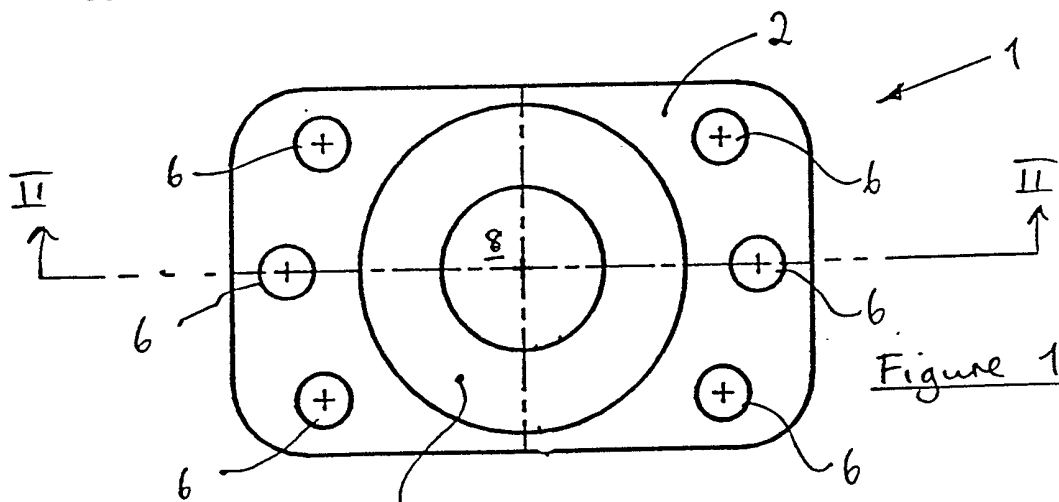

Figure 1

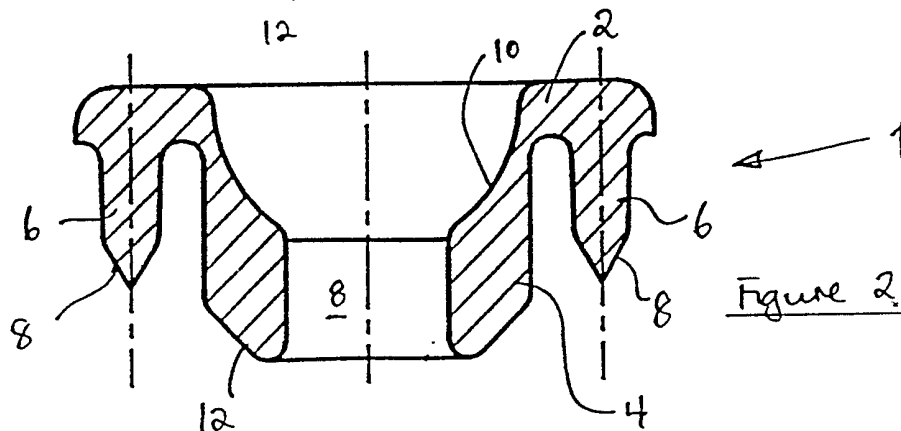
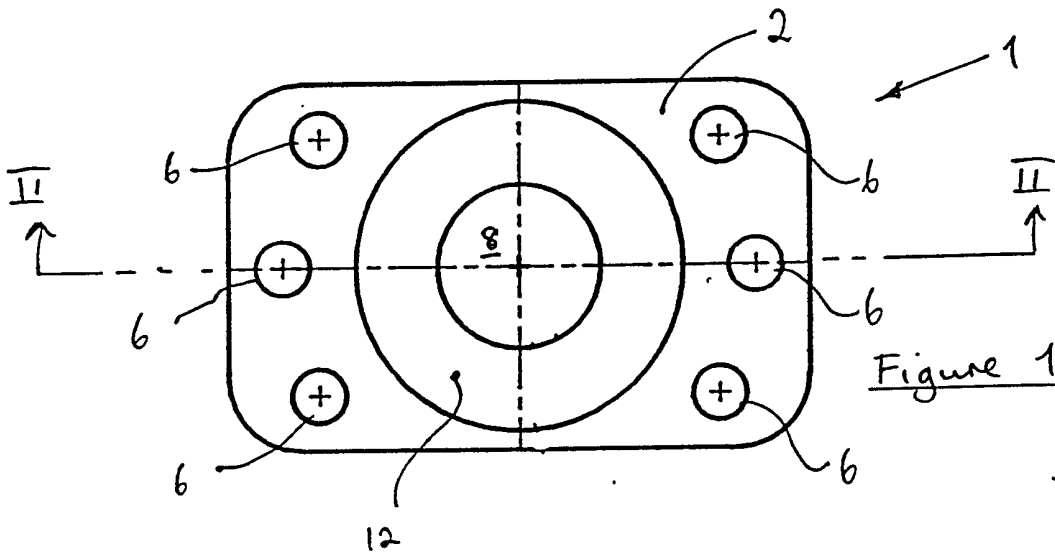
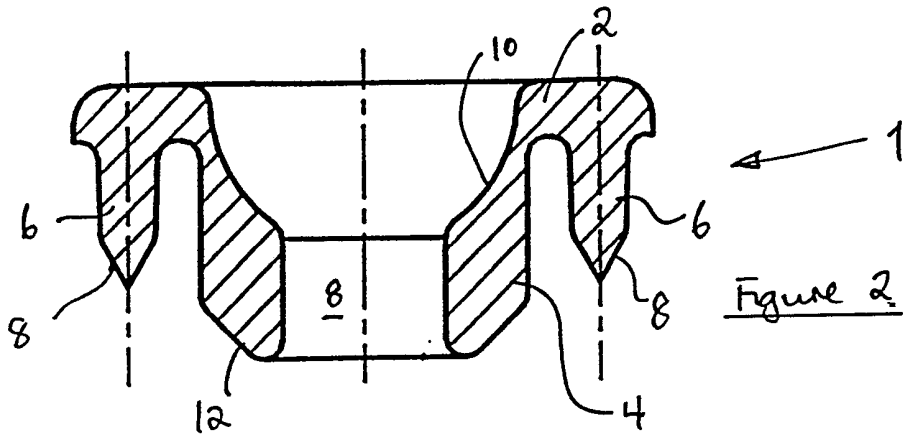

Figure 2



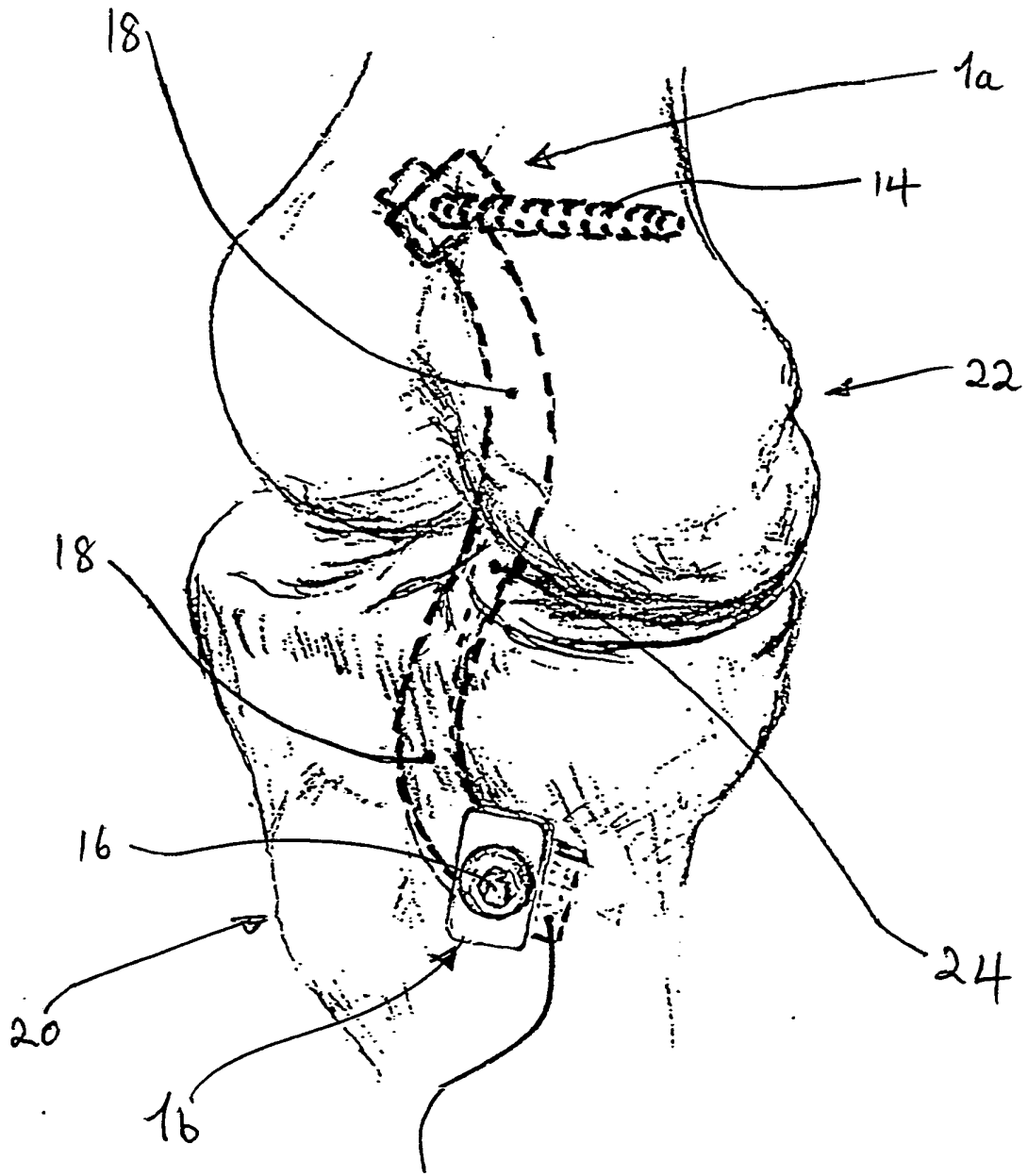

Figure 3

LIGAMENT FIXATOR

This invention relates to a ligament fixator.

In the repair and replacement of ligaments in the human body, it is known that there is difficulty in
5 securely fixing a prosthesis (synthetic ligament) to the bone, or reattaching the natural ligament to bone. The present invention is intended to overcome this problem.

Knee ligaments are commonly damaged accidentally, often whilst participating in sporting activity such as
10 soccer or skiing. The ligament may be damaged such that it may need to be repaired by, for example, suturing, replaced entirely using a prosthetic replacement or replaced using a prosthetic ligament but augmented with host's tissue. Repair sometimes involves reattaching
15 the natural ligament to bone, and replacement usually requires attachment of a prosthesis to bone.

There are a number of techniques that are known for the attachment of ligament to bone. These include the use of screws, grommets and staples.

20 A number of ligament prostheses of an open weave design have been described (see, for instance, EP-A-0126520 and EP-A-0358324). EP-A-0126520 describes fixation using a bone plug technique, but some surgeons prefer other fixation methods for certain conditions.

25 An open weave design fabric, whilst permitting the desirable rapid ingrowth of natural body tissues, makes the fixation difficult if conventional screws and grommets are used. When a screw is placed through the fabric and load is applied to the prosthesis, the load
30 is transferred through the fabric to the bone in such a way that much of the load is applied to the widthways weft yarn of the prosthesis. The weft yarn is able to slip relative to the lengthways warp yarns, and the fabric is damaged and the load is not transferred to the
35 bone. The use of a washer on the screw helps the fixation because the load is transferred to a number of warp and weft fibres by friction between the fibres and

the washer. However, the method is not reliable or secure enough for routine use.

A grommet is described in J. Bone Joint Surg. [Br] 1988 70-B 397-403 which acts as a bollard fixation
5 device for yarns wrapped around it. This is, however, unsuitable for fixing an open weave fabric since the fabric still pulls around the post of the grommet.

A simple spiked washer has been used, an example of which is known as the "AO" bone washer. This washer
10 fits around a conventional bone screw, but permits the bone screw to be pulled through the bone when steady loads are applied.

According to the present invention, there is provided a ligament fixator for use in securing a
15 natural or synthetic ligament to a bone, comprising a base plate which is provided on one side thereof with a pillar extending generally perpendicular from the plate and including a longitudinal passage which extends
20 through the pillar and the plate to define a bore for a bone screw, said base plate also including, on the same side as the pillar, and also extending generally perpendicular to the pillar, a series of projections capable of penetrating said ligament and bone.

Each of the projections may be tapered towards its
25 free end to assist in parting of the fibres of the ligament and bone. It is to be appreciated, however, that the projections could be blunt if pilot holes for the projections are drilled in the bone before use of the fixator. The projections are narrow relative to the
30 width of the pillar and preferably each projection projects from the base plate a distance slightly less than the length of the pillar; this ensures that the fixator locates in a pre-drilled guide hole in the bone before the projections engage the ligament and bone.
35 The base plate and projections ensure that, when a load is applied to the plate, the fixator will not be pulled through the bone, and will also grip the fabric

securely.

In a preferred embodiment of the ligament fixator of the present invention, the base plate is generally rectangular having a single, centrally disposed pillar. 5 The projections are preferably arranged on the base plate in a manner such that the bone fixator is symmetrical about first and second axes through the centre of the base plate parallel to the longer sides and shorter sides respectively of the rectangular base 10 plate. Typically, there are six projections (although there can be more or less) divided into two groups of three with each group of three projections being disposed to an opposite side of the said second axis which is parallel to the shorter sides of the base 15 plate. The projections are preferably not arranged in a straight line so that they can penetrate and grip different warp ends of the fabric and so spread load across more of the bone.

There is preferably a single pillar which is 20 somewhat wider than the corresponding bone screw to be used in order to provide a support for the screw. The passage in the pillar is preferably slightly wider than the diameter of the bone screw. The pillar assists in spreading the load over a wider section of bone, to 25 prevent the possibility of migration of the screw through the bone when loads are applied. The pillar is preferably cylindrical, more preferably circularly cylindrical. The end of the pillar opposite to the base plate may be provided with a slight taper which assists 30 in enabling the pillar to part fibres in the ligament and pass through the ligament without cutting the fibres and hence weakening the ligament. More than one pillar may be employed where the ligament to be secured is particularly wide.

35 The bore for the bone screw may be countersunk at the base plate end so that the head of the bone screw, when fixed into the bone, lays level with the outer

surface of the plate.

The ligament fixator of the present invention is particularly suited for use with synthetic ligaments of an open-weave design. The fibres of the open weave
5 ligament are readily parted by the tapered projections of the ligament fixator.

For a better understanding of the present invention, and to show how the same may be carried into effect, reference will now be made, by way of example,
10 to the accompanying drawings in which:

Figure 1 is an underside view of a ligament fixator in accordance with the present invention;

Figure 2 is a section on the line II-II of Figure 1; and

15 Figure 3 illustrates the use of ligament fixators in accordance with the present invention.

With reference to Figures 1 and 2, ligament fixator 1 comprises a generally rectangular base plate 2, which is provided with a cylindrical pillar 4 and six
20 projections 6. The pillar 4 is provided with a bore 8 which is countersunk 10 at the base plate end; at its other end 12, the pillar 4 is slightly tapered. At their free end regions, each of the projections 6 tapers towards its free end 8. It will be noted that each
25 projection 6 is substantially narrower than the pillar 4.

The projections 6 are arranged symmetrically about the pillar 4, with three projections 6 on each side of the pillar 4. The rectangular base plate 2 is slightly
30 wider than the diameter of the pillar 4; its length however, is sufficient to accommodate on each side the three projections 6.

Typically, the base plate 2 measures 16mm by 10mm, and is 1mm thick. The bore 8 for the bone screw is
35 about 4.5mm internal diameter. The pillar 4 has an outer diameter of about 9mm which is tapered at free end 12 to about 5mm and has a total length of about 7mm

extending from the plate 2. The projections 6 protrude about 4mm from the plate 2 and are capable of penetrating the ligament and the bone. The projections 6 are set such that the centre of each projection 6 is approximately 2mm from the outer edge of the central screw bore 8. Thus, the projections 6 are not in a straight line parallel with the shorter edge of the plate 2 and therefore grip different warp ends of the fabric, and so spread the load across more of the fabric, and improve load transference from fabric to bone.

In Figure 3, the use of ligament fixators 1a, 1b in accordance with the present invention is illustrated. The fixators 1a, 1b are used in Fossa adjacent to the tibial tuberosity. Each fixator 1 is secured by a bone screw 14 having a head 16 which rests on the inside of the countersunk area 10 of the fixator 1. The fixators 1a, 1b secure an artificial ligament 18 (for instance an artificial ligament made by the present applicant, Biomet Limited of South Glamorgan, U.K., and known as a Bio-ligament). This artificial ligament 18 passes through holes in the tibia 20 and femur 22 and is secured at each end by a fixator 1a, 1b. The ligament 18 may be enclosed in natural tissue in the joint space 24 between the tibia 20 and femur 22. The ligament 18 is secured at the back of the femur 22 by fixator 1a and at the front of the tibia 20 by fixator 1b. The projections 6 in the fixator 1 part the fibres of the artificial ligament 18 and firmly secure it at each end to the bone.

The rectangular shape of the plate 2 is such that, by way of example, the plate 2 fits snugly under the tibial tuberosity of the knee, and does not protrude a great distance above the surface of the bone. This is so that the skin above the fixator 1 is less likely to chafe, and so should not need to be removed in a surgical operation at a later date.

The immediate high fixation strength provided by the ligament fixator of the present invention means that the patient need not be immobilised post-operatively.

CLAIMS

1. A ligament fixator for use in securing a natural or synthetic ligament to a bone, comprising a base plate which is provided on one side thereof with a pillar extending generally perpendicular from the plate and including a longitudinal passage which extends through the pillar and the plate to define a bore for a bone screw, said base plate also including, on the same side as the pillar, and also extending generally perpendicular to the pillar, a series of projections capable of penetrating said ligament and bone.
2. A ligament fixator according to claim 1, wherein each of the projections is tapered towards its free end.
3. A ligament fixator according to claim 1 or 2, wherein the projections are narrow relative to the width of the pillar.
4. A ligament fixator according to claim 1, 2 or 3, wherein each projection projects from the base plate a distance slightly less than the length of the pillar.
5. A ligament fixator according to any preceding claim, wherein the base plate is generally rectangular having a single, centrally disposed pillar.
6. A ligament fixator according to claim 5, wherein the projections are arranged on the base plate in a manner such that the fixator is symmetrical about first and second axes through the centre of the base plate, parallel to the longer sides and shorter sides respectively of the base plate.
7. A ligament fixator according to any preceding claim, wherein there are six projections divided into two groups of three, with each group of three projections being disposed to an opposite side of the said second axes which is parallel to the shorter sides of the base plate.
8. A ligament fixator according to claim 7, wherein the projections are not in line.

9. A ligament fixator substantially as hereinbefore described, with reference to the accompanying drawings.

10. A combination of a natural or synthetic
5 ligament and a ligament fixator as claimed in any one of the preceding claims.

Patents Act 1977
Examiner's report to the Comptroller under
Section 17 (The Search Report)

Application number 9021934.6

Relevant Technical fields

(i) UK CI (Edition K) A5R (RAM, RAP)

(ii) Int CI (Edition 5) A61F

Search Examiner

L V THOMAS

Databases (see over)

(i) UK Patent Office

(ii)

Date of Search

10 December 1990

Documents considered relevant following a search in respect of claims

1-10

Category (see over)	Identity of document and relevant passages	Relevant to claim(s)
A	EP A 0279129 (CEROL BANDEIRA ET AL) See line 50 column 2 - line 17 column 3 and figures 1-4	1,2
X	EP A 0238223 (MINNESOTA MINING) See lines 34-57 column 4 and figure 4	1-3, 6-8, 10

SF2(p)