

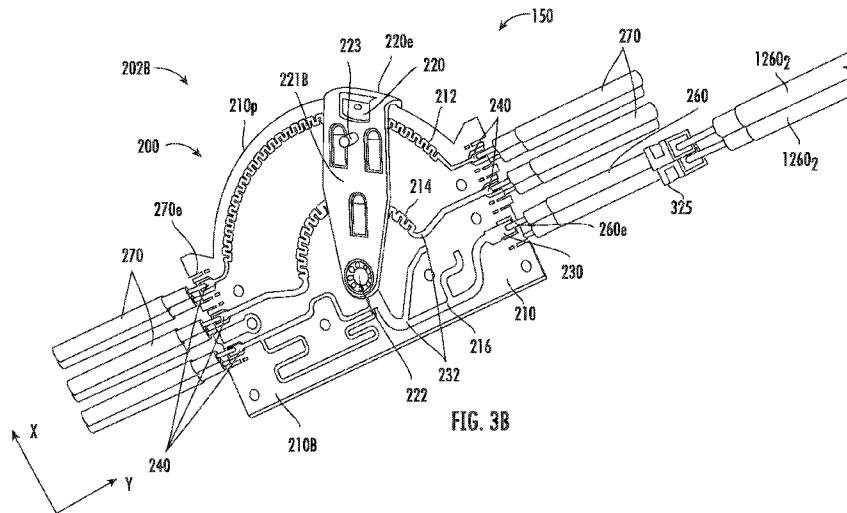

- (51) International Patent Classification:
H01P 1/18 (2006.01) H01Q 3/32 (2006.01)
- (21) International Application Number:
PCT/US2019/051873
- (22) International Filing Date:
19 September 2019 (19.09.2019)
- (25) Filing Language: English
- (26) Publication Language: English
- (30) Priority Data:
62/733,721 20 September 2018 (20.09.2018) US
62/828,831 03 April 2019 (03.04.2019) US
62/877,484 23 July 2019 (23.07.2019) US
- (71) Applicant: COMMSCOPE TECHNOLOGIES LLC
[US/US]; 1100 CommScope Place SE, Hickory, North Carolina 28602 (US).
- (72) Inventors: TANG, Haidan; Suzhou, Jiangsu (CN). YU, Junfeng; Suzhou, Jiangsu (CN). WANG, Dongmin; Suzhou, Jiangsu (CN). LIU, Chaohui; Suzhou, Jiangsu (CN). MERTA, Samantha L.; 110 West Cityline Dr, Richardson, Texas 75082 (US). WEN, Hangsheng; Suzhou, Jiangsu (CN). KAISTHA, Amit; 668 Deforest Road, Coppell, Texas 75019 (US). P, Muhammed Ameer; Kerala (IN).
- (74) Agent: DEROSA, Anthony, P.; MYERS BIGEL, P.A., PO Box 37428, Raleigh, North Carolina 27627 (US).
- (81) Designated States (unless otherwise indicated, for every kind of national protection available): AE, AG, AL, AM, AO, AT, AU, AZ, BA, BB, BG, BH, BN, BR, BW, BY, BZ,

(54) Title: BASE STATION ANTENNAS HAVING DOUBLE-SIDED PHASE SHIFTERS



(57) Abstract: A phase shifter assembly, suitable for a base station antenna, includes a main printed circuit board with opposing first and second primary sides. The main printed circuit board has a plurality of radio frequency (RF) transmission paths on the first primary side and a plurality of RF transmission paths on the second primary side. The phase shifter assembly also includes a first wiper arm rotatably coupled to the main printed circuit board and electrically coupled to the plurality of transmission paths on the first primary side of the main printed circuit board; and a second wiper arm rotatably coupled to the main printed circuit board and electrically coupled to the plurality of transmission paths on the second primary side of the main printed circuit board. Rearwardly extending phase shifter assemblies that are oriented perpendicular to a plane defined by a reflector within a base station antenna are also provided.



WO 2020/061275 A1

CA, CH, CL, CN, CO, CR, CU, CZ, DE, DJ, DK, DM, DO, DZ, EC, EE, EG, ES, FI, GB, GD, GE, GH, GM, GT, HN, HR, HU, ID, IL, IN, IR, IS, JO, JP, KE, KG, KH, KN, KP, KR, KW, KZ, LA, LC, LK, LR, LS, LU, LY, MA, MD, ME, MG, MK, MN, MW, MX, MY, MZ, NA, NG, NI, NO, NZ, OM, PA, PE, PG, PH, PL, PT, QA, RO, RS, RU, RW, SA, SC, SD, SE, SG, SK, SL, SM, ST, SV, SY, TH, TJ, TM, TN, TR, TT, TZ, UA, UG, US, UZ, VC, VN, ZA, ZM, ZW.

- (84) Designated States** (*unless otherwise indicated, for every kind of regional protection available*): ARIPO (BW, GH, GM, KE, LR, LS, MW, MZ, NA, RW, SD, SL, ST, SZ, TZ, UG, ZM, ZW), Eurasian (AM, AZ, BY, KG, KZ, RU, TJ, TM), European (AL, AT, BE, BG, CH, CY, CZ, DE, DK, EE, ES, FI, FR, GB, GR, HR, HU, IE, IS, IT, LT, LU, LV, MC, MK, MT, NL, NO, PL, PT, RO, RS, SE, SI, SK, SM, TR), OAPI (BF, BJ, CF, CG, CI, CM, GA, GN, GQ, GW, KM, ML, MR, NE, SN, TD, TG).

Published:

- *with international search report (Art. 21(3))*
- *before the expiration of the time limit for amending the claims and to be republished in the event of receipt of amendments (Rule 48.2(h))*

**BASE STATION ANTENNAS HAVING DOUBLE-SIDED PHASE SHIFTERS
AND/OR REARWARDLY EXTENDING PHASE SHIFTERS AND
ASSOCIATED PHASE SHIFTER ASSEMBLIES**

STATEMENT OF PRIORITY

[0001] The present application claims priority from and the benefit of U.S. Provisional Application Serial No. 62/733,721, filed September 20, 2018, U.S. Provisional Application Serial No. 62/828,831, filed April 3, 2019, and U.S. Provisional Application Serial No. 62/877,484, filed July 23, 2019, the disclosures of which are hereby incorporated herein in their entirety.

FIELD

[0002] The present invention relates to communication systems and, in particular, to base station antennas having remote electronic tilt capabilities.

BACKGROUND

[0003] Cellular communications systems are used to provide wireless communications to fixed and mobile subscribers. A cellular communications system may include a plurality of base stations that each provides wireless cellular service for a specified coverage area that is typically referred to as a "cell." Each base station may include one or more base station antennas that are used to transmit radio frequency ("RF") signals to, and receive RF signals from, the subscribers that are within the cell served by the base station. Base station antennas are directional devices that can concentrate the RF energy that is transmitted in or received from certain directions. The "gain" of a base station antenna in a given direction is a measure of the ability of the antenna to concentrate the RF energy in that direction. The "radiation pattern" of a base station antenna – which is also referred to as an "antenna beam" – is a compilation of the gain of the antenna across all different directions. Each antenna beam may be designed to service a pre-defined coverage area such as the cell or a portion thereof that is referred to as a "sector." Each antenna beam may be designed to have minimum gain levels throughout the pre-defined coverage area, and to have much lower gain levels outside of the coverage area to reduce interference between neighboring cells/sectors. Base station antennas typically comprise a linear array of radiating elements such as patch, dipole or

crossed dipole radiating elements. Many base station antennas now include multiple linear arrays of radiating elements, each of which generates its own antenna beam.

[0004] Early base station antennas generated antenna beams having fixed shapes, meaning that once a base station antenna was installed, its antenna beam(s) could not be changed unless a technician physically reconfigured the antenna. Many modern base station antennas now have antenna beams that can be electronically reconfigured from a remote location. The most common way in which an antenna beam may be reconfigured electronically is to change the pointing direction of the antenna beam (i.e., the direction in which the antenna beam has the highest gain), which is referred to as electronically "steering" the antenna beam. An antenna beam may be steered horizontally in the azimuth plane and/or vertically in the elevation plane. An antenna beam can be electronically steered by transmitting control signals to the antenna that cause the antenna to alter the phases of the sub-components of the RF signals that are transmitted and received by the individual radiating elements of the linear array that generates the antenna beam. Most modern base station antennas are configured so that the elevation or "tilt" angle of the antenna beams generated by the antenna can be electronically altered. Such antennas are commonly referred to as remote electronic tilt ("RET") antennas.

[0005] In order to electronically change the down tilt angle of an antenna beam generated by a linear array of radiating elements, a phase taper may be applied across the radiating elements of the array. Such a phase taper may be applied by adjusting the settings on a phase shifter that is positioned along the RF transmission path between a radio and the individual radiating elements of the linear array. One widely-used type of phase shifter is an electromechanical "wiper" phase shifter that includes a main printed circuit board and a "wiper" printed circuit board that may be rotated above the main printed circuit board. Such wiper phase shifters typically divide an input RF signal that is received at the main printed circuit board into a plurality of sub-components, and then couple at least some of these sub-components to the wiper printed circuit board. The sub-components of the RF signal may be coupled from the wiper printed circuit board back to the main printed circuit board along a plurality of arc-shaped traces, where each arc has a different diameter. Each end of each arc-shaped trace may be connected to a respective sub-group of one or more radiating elements. By physically (mechanically) rotating the wiper printed circuit board above the main printed circuit board, the locations where the sub-components of the RF signal couple back to the main printed circuit board may be changed, which thus changes the lengths of the transmission paths from the phase shifter to the respective sub-groups of radiating elements.

The changes in these path lengths result in changes in the phases of the respective sub-components of the RF signal, and since the arcs have different radii, the phase changes along the different paths will be different. Typically, the phase taper is applied by applying positive phase shifts of various magnitudes (e.g., $+X^\circ$, $+2X^\circ$ and $+3X^\circ$) to some of the sub-components of the RF signal and by applying negative phase shifts of the same magnitudes (e.g., $-X^\circ$, $-2X^\circ$ and $-3X^\circ$) to additional of the sub-components of the RF signal. Exemplary phase shifters of this variety are discussed in U.S. Patent No. 7,907,096 to Timofeev, the disclosure of which is hereby incorporated herein in its entirety. The wiper printed circuit board is typically moved using an electromechanical actuator such as a DC motor that is connected to the wiper printed circuit board via a mechanical linkage. These actuators are often referred to as "RET actuators." Both individual RET actuators that drive a single mechanical linkage and "multi-RET actuators" that have a plurality of output members that drive a plurality or respective mechanical linkages are commonly used in base station antennas.

SUMMARY

[0006] Pursuant to embodiments of the present invention, base station antennas and/or phase shifter assemblies suitable for base station antennas include double sided printed circuit boards (PCB) providing dual phase shifters, one on each side of the PCB.

[0007] Pursuant to embodiments of the present invention, base station antennas and/or phase shifter assemblies suitable for base station antennas comprise stacked pairs of PCBs with a back panel, with the back panel separating the pairs of PCB and with a wiper sub-assembly coupled to each respective pair of the PCBs.

[0008] Pursuant to embodiments of the present invention, base station antennas are provided that include pairs of PCBs that are mounted substantially perpendicular to a plane defined by a reflector of the base station antenna.

[0009] Embodiments of the invention are directed to a phase shifter assembly that includes a main printed circuit board comprising opposing first and second primary sides. The main printed circuit board has a plurality of radio frequency (RF) transmission paths on the first primary side and a plurality of RF transmission paths on the second primary side. The assembly also includes a first wiper arm rotatably coupled to the main printed circuit board and electrically coupled to at least some of the plurality of transmission paths on the first primary side of the main printed circuit board and a second wiper arm rotatably coupled

to the main printed circuit board and electrically coupled to at least some of the plurality of transmission paths on the second primary side of the main printed circuit board.

[0010] The phase shifter assembly can further include a plurality of coaxial cables coupled to each of the first and second primary sides of the main printed circuit board.

[0011] The main printed circuit board can have a ground plane sandwiched between opposing dielectric layers.

[0012] The phase shifter assembly can further include a plurality of input and/or output pads coupled to the plurality of RF transmission paths on each of the first and second primary sides of the main printed circuit board.

[0013] The input and/or output pads on the first primary side can be laterally and/or longitudinally offset from the input and/or output pads on the second primary side.

[0014] The phase shifter assembly can further include a pivot pin extending through an aperture in the main printed circuit board defining a pivot point. The pivot pin can be coupled to both the first and second wiper arms.

[0015] The main printed circuit board can have an arcuate slot residing adjacent an arcuate segment of at least one of the plurality of RF transmission paths. The first and second wiper arms can cooperate with the slot and the pivot pin to rotate back and forth over the RF transmission paths.

[0016] The main printed circuit board can have an arcuate top side residing adjacent an arcuate segment of at least one of the plurality of RF transmission paths.

[0017] The phase shifter assembly can further include at least one connector block assembly attached to the main printed circuit board. The at least one connector block assembly can be configured to hold a plurality of coaxial cables in first and second stacked rows. The first row can hold the coaxial cables coupled to the first primary side of the main printed circuit board and the second row can hold the coaxial cables coupled to the second primary side of the main printed circuit board.

[0018] The phase shifter assembly can further include at least one transition block connector that can reside completely outside a boundary of the main printed circuit board and can couple a first pair of larger coaxial cables to a corresponding first pair of smaller outer diameter coaxial cables. One coaxial cable of the pair of the smaller outer diameter coaxial cables can couple to the first primary side of the main printed circuit board while another coaxial cable of the pair of the smaller outer diameter coaxial cables can couple to the second primary side of the main printed circuit board.

[0019] At least some of the coaxial cables can have end portions that have a first terminal end segment that merges into a second terminal end segment. The first terminal end segment can have an axially extending center line. The second terminal end segment can be bent to reside closer to the main printed circuit board than the first terminal end segment, optionally at an angle between 45 and 90 degrees from the axially extending center line of the first terminal end segment.

[0020] The main printed circuit board can have a thickness in a range of about 2 mm to about 10 mm, optionally a range of about 3 mm to about 5 mm.

[0021] The main printed circuit board can have a perimeter. The perimeter can include a pair of long sides and a pair of short sides, with one long side defining a bottom and one long side defining a top. The main printed circuit board can have input and/or output pads on the first primary side that can be offset in an X direction from input and/or output pads on the second primary side, with the X direction defined as extending in a direction between the top and bottom.

[0022] The main printed circuit board can have a perimeter. The perimeter can have a pair of long sides and a pair of short sides, with one long side defining a bottom and one long side defining a top. Input and/or output pads on the first and second primary surfaces can include a plurality of pads that can reside adjacent the top and a plurality of pads that can reside adjacent the bottom of the main printed circuit board.

[0023] The input pad on the first primary side can reside in a bottom corner or a top corner of the main printed circuit board. The input pad on the second primary side can reside in the other of the bottom corner or the top corner across a Y direction of the main printed circuit board. Optionally, the main printed circuit board can have an arcuate slot that resides adjacent an arcuate segment of one of the transmission lines.

[0024] The main printed circuit board can have a top and an opposing bottom. The top can be positioned closer to an outer edge of the first and second wiper arms than the bottom. The main printed circuit board can have input and/or output pads on the first primary side that can be above the slot and further away from the pivot pin closer to the wiper arm. The main printed circuit board can also have input and/or output pads on the second primary side that can be below the slot.

[0025] The pivot pin can reside at a medial location of the main printed circuit board, optionally centered in a Y direction where the Y direction corresponds to a lateral direction associated with a primary direction of the transmission paths.

[0026] The pivot pin can reside closer to a bottom side of the main printed circuit board than the top side of the main printed circuit board, optionally centered in a Y direction where the Y direction corresponds to a lateral direction associated with a primary direction of the transmission paths.

[0027] The first and second wiper arms can be coupled together at a respective outer edge portion.

[0028] Embodiments of the invention include a base station antenna with a housing enclosing the phase shifter assembly. Optionally (a) the phase shifter assembly can be held in a vertical orientation in the housing with the main printed circuit board vertically oriented; or (b) the phase shifter assembly can be held in a horizontal orientation in the housing with the main printed circuit board horizontally oriented.

[0029] Embodiments of the invention are directed to a base station antenna. The base station antenna includes: a plate (optionally a metal plate) comprising opposing first and second primary surfaces and a first slot; a first main printed circuit board comprising a plurality of radio frequency (RF) transmission paths residing on the first primary surface of the plate; a second main printed circuit board comprising a plurality of RF transmission paths residing on the second primary surface of the plate, aligned with the first main printed circuit board; a first wiper arm rotatably coupled to the first main printed circuit board; and a second wiper arm rotatably coupled to the second main printed circuit board. The first and second wiper arms cooperate with the first slot in the plate and a pivot pin extending through the first and second main printed circuit boards and the plate to be able to rotate in concert relative to the first and second main printed circuit boards to thereby adjust lengths of RF transmission paths on respective first and second main printed circuit boards.

[0030] The plate can have a second slot adjacent the first slot. The base station antenna can further include: a third main printed circuit board residing adjacent the first main printed circuit board and on the first primary surface of the plate; a fourth main printed circuit board residing adjacent the second main printed circuit board and on the second primary surface of the plate; a third wiper arm rotatably coupled to the third main printed circuit board; and a fourth wiper arm rotatably coupled to the fourth main printed circuit board. The third and fourth wiper arms can cooperate with the second slot in the plate and a pivot pin extending through the third and fourth main printed circuit boards and the plate. The third and fourth wiper arms can rotate in concert relative to the third and fourth main printed circuit boards to thereby adjust lengths of RF transmission paths on respective third and fourth main printed circuit boards.

[0031] The base station antenna can further include a plurality of cable channels held by or defined by the plate that can route a plurality of coaxial cables to the first and second main printed circuit boards.

[0032] The first and second slots can be arcuate slots and can reside at a medial location of the plate. The first arcuate slot can have a first radius of curvature and the second arcuate slot can have a second radius of curvature. The first and second radius of curvatures can be the same but can be oriented to provide opposing arc segments.

[0033] The first, second, third and fourth main printed circuit boards can have a perimeter. The perimeter can have a pair of long sides and a pair of short sides. One long side of the pair of long sides can define a bottom and another long side of the pair of long sides can define a top. The tops of the first and third printed circuit boards can be arcuate and can reside adjacent each other with the first and second slots therebetween. The tops of the second and fourth printed circuit boards can be arcuate and can reside adjacent each other with the first and second slots therebetween.

[0034] The plurality of cable channels can be defined at least partially by a connector block assembly or a transition block connector.

[0035] The phase shifter assembly can be held in a vertical orientation with the plate and the first and second printed circuit boards parallel to each other and vertically oriented.

[0036] The phase shifter assembly can be held in a horizontal orientation with the plate and the first and second printed circuit boards parallel to each other and horizontally oriented.

[0037] Embodiments of the present invention are directed to a base station antenna. The base station antenna may include a reflector; and a plurality of rearwardly extending phase shifter assemblies, where each of the phase shifter assemblies are aligned substantially perpendicular to a plane defined by the reflector.

[0038] Each phase shifter assembly of the base station antenna may include a first and a second plate arranged back-to-back and extending parallel to each other. Each plate may include an outer surface, a first main printed circuit board residing on the outer surface of the first plate, the first main printed circuit board comprising a plurality of radio frequency (RF) transmission paths, a second main printed circuit board residing on the outer surface of the second plate, the second main printed circuit board including a plurality of RF transmission paths. The second main printed circuit board may be aligned with the first main printed circuit board, a first wiper rotatably coupled to the first main printed circuit board, the first wiper having a first attachment link, and a second wiper rotatably coupled to the second main printed circuit board, the second wiper having a second attachment link. The first attachment

link of the first wiper and the second attachment link of the second wiper are each configured to couple their respective wiper to a drive shaft of a mechanical linkage, where the first and second wipers are configured to rotate in concert relative to the first and second main printed circuit boards to thereby adjust lengths of RF transmission paths on respective first and second main printed circuit boards.

[0039] Each phase shifter assembly of the base station antenna may include one or more mounting flanges, each mounting flange being configured to mount the phase shifter assembly to the reflector or a support member.

[0040] The plurality of phase shifter assemblies may be mounted to the reflector by the mounting flanges.

[0041] The plurality of phase shifter assemblies may be mounted on the support member by the mounting flanges.

[0042] The mechanical linkage of each phase shifter assembly may reside in the same transverse plane.

[0043] The base station antenna may include an AISG PING printed circuit board that extends perpendicular to the plurality of phase shifter assemblies.

[0044] The plurality of phase shifter assemblies may be coupled to the AISG PING printed circuit board through respective blind mated or cabled connections.

[0045] The base station antenna may include a calibration circuit board extending perpendicular to the plurality of phase shifter assemblies.

[0046] The plurality of phase shifter assemblies may be coupled to the calibration circuit board through respective blind mated or cabled connections.

[0047] The base station antenna may include about 10 to about 30 phase shifter assemblies.

[0048] Embodiments of the present invention are directed to a method of assembling a base station antenna. The method may include providing a plurality of phase shifter assemblies, each phase shifter assembly including a first plate and a second plate arranged back-to-back and extending parallel to each other, mounting each phase shifter assembly to a support member such that the first and second plates are oriented perpendicular to the support member, and integrating the support member including the plurality of phase shifter assemblies mounted thereon into the base station antenna.

[0049] The method may include integrating an AISG PING printed circuit board extending perpendicular to the plurality of phase shifter assemblies.

[0050] The method may include integrating a calibration printed circuit board extending perpendicular to the plurality of phase shifter assemblies.

[0051] Embodiments of the present invention are directed to a phase shifter assembly adapted for mitigating passive intermodulation within a base station antenna. The assembly may include a polymeric mounting base having opposing first and second primary sides, a first main printed circuit board residing on the first primary side, the first main printed circuit board including a plurality of radio frequency (RF) transmission paths, and a second main printed circuit board residing on the second primary side, the second main printed circuit board including a plurality of RF transmission paths. The second main printed circuit board is aligned with the first main printed circuit board. The assembly may further include a first wiper rotatably coupled to the first main printed circuit board, the first wiper having a first attachment link, and a second wiper rotatably coupled to the second main printed circuit board, the second wiper having a second attachment link. The first attachment link of the first wiper and the second attachment link of the second wiper are each configured to couple their respective wiper to a drive shaft of a mechanical linkage. The first and second wipers are configured to rotate in concert relative to the first and second main printed circuit boards to thereby adjust lengths of RF transmission paths on respective first and second main printed circuit boards.

[0052] The phase shifter assembly may have a depth in the range of about 25 mm to about 35 mm, a length in the range of about 180 mm to about 190 mm, and a width in the range of about 80 mm to about 90 mm.

[0053] Embodiments of the present invention are directed to a base station antenna. The base station antenna may include a reflector and a plurality of phase shifter assemblies. Each phase shifter assembly may include a polymeric mounting base comprising opposing first and second primary sides, a first main printed circuit board residing on the first primary side, the first main printed circuit board including a plurality of radio frequency (RF) transmission paths, and a second main printed circuit board residing on the second primary side, the second main printed circuit board including a plurality of RF transmission paths. The second main printed circuit board is aligned with the first main printed circuit board. Each phase shifter assembly may further include a first wiper rotatably coupled to the first main printed circuit board, the first wiper having a first attachment link and a second wiper rotatably coupled to the second main printed circuit board, the second wiper having a second attachment link. The first attachment link of the first wiper and the second attachment link of the second wiper are each configured to couple their respective wiper to a drive shaft of a

mechanical linkage. The first and second wipers are configured to rotate in concert relative to the first and second main printed circuit boards to thereby adjust lengths of RF transmission paths on respective first and second main printed circuit boards.

[0054] The base station antenna may include at least two phase shifter assemblies. The first and second attachment links of one of the at least two phase shifter assemblies and the first and second attachment links of the second of the at least two phase shifter assemblies are configured to couple their respective wipers to a drive link that is coupled to the drive shaft of the mechanical linkage. The first and second wipers of each of the at least two phase shifter assemblies are configured to rotate in concert relative to their respective first and second main printed circuit boards to thereby adjust the phase of the base station antenna.

[0055] The polymeric mounting base of each phase shifter assembly may include mounting holes, and each of the phase shifter assemblies may be mounted to the reflector with nylon screws or rivets received through the mounting holes.

[0056] Each phase shifter assembly of the base station antenna may include mounting features integral with the polymeric mounting base and configured to be received by a plurality of mounting apertures in the reflector.

[0057] The mounting features of the mounting base may include a snap-lock or snap-fit feature.

BRIEF DESCRIPTION OF THE DRAWINGS

[0058] **FIG. 1A** is a perspective view of an example base station antenna according to embodiments of the present invention.

[0059] **FIG. 1B** is a perspective view of the base station antenna of **FIG. 1A** with the radome thereof removed.

[0060] **FIG. 2** is a schematic block diagram illustrating the electrical connections between various of the components of the base station antenna of **FIGS. 1A-1B**.

[0061] **FIG. 3A** is a perspective first primary side view of an electromechanical phase shifter assembly with phase shifters that may be included in the base station antenna of **FIGS. 1A-1B** according to embodiments of the present invention.

[0062] **FIG. 3B** is a perspective opposing second primary side view of the electromechanical phase shifters shown in **FIG. 3A**.

[0063] **FIG. 4A** is a top view of the first primary side of the device shown in **FIG. 3A**.

[0064] **FIG. 4B** is a bottom view of the second primary side of the device shown in **FIG. 3A**.

[0065] FIG. 5 is a greatly enlarged end view of the device shown in FIG. 3A, shown without the coaxial cables.

[0066] FIG. 6 is a partial primary side view of the device shown in FIG. 3A with a bracket and drive shaft according to embodiments of the present invention.

[0067] FIG. 7A is an enlarged minor side view of the device shown in FIG. 3A.

[0068] FIG. 7B is a greatly enlarged perspective view of the cable connector shown in FIG. 7A according to embodiments of the present invention.

[0069] FIG. 8A is a perspective first primary side view of electromechanical phase shifters that may be included in the base station antenna of FIGS. 1A-1B according to additional embodiments of the present invention

[0070] FIG. 8B is a perspective opposing second primary side view of the electromechanical phase shifters shown in FIG. 8A.

[0071] FIG. 9A is a top view of the first primary side of the device shown in FIG. 8A.

[0072] FIG. 9B is a bottom view of the second primary side of the device shown in FIG. 8A.

[0073] FIG. 10A is a greatly enlarged perspective, minor side view of the device shown in FIG. 8A.

[0074] FIG. 10B is an exploded view of an example cable connector assembly for the device shown in FIG. 8A according to embodiments of the present invention.

[0075] FIG. 11A is a perspective first primary side view of electromechanical phase shifters that may be included in the base station antenna of FIGS. 1A-1B according to additional embodiments of the present invention

[0076] FIG. 11B is a perspective opposing second primary side view of the electromechanical phase shifters shown in FIG. 11A.

[0077] FIG. 11C is a side, top perspective view of the device shown in FIG. 11A.

[0078] FIG. 12 is a greatly enlarged perspective, minor side view of the device shown in FIG. 11A.

[0079] FIG. 13 is a greatly enlarged view of the PCB cable interface of the device shown in FIG. 12.

[0080] FIG. 14A is a top view of a first primary side of an example PCB for a phase shifter according to embodiments of the present invention.

[0081] FIG. 14B is a bottom view of a second primary side of the example PCB shown in FIG. 14A.

[0082] FIG. 15A is a top view of a first primary side of another example PCB for a phase shifter according to embodiments of the present invention.

[0083] FIG. 15B is a bottom view of the second primary side of the example PCB shown in FIG. 15A.

[0084] FIG. 16A is a top view of a first primary side of yet another example PCB for a phase shifter according to embodiments of the present invention.

[0085] FIG. 16B is a bottom view of the second primary side of the example PCB shown in FIG. 16A.

[0086] FIG. 17A is a top perspective view of a first primary side of another embodiment of a phase shifter assembly with phase shifters according to embodiments of the present invention.

[0087] FIG. 17B is a bottom perspective view of a second primary side of the device shown in FIG. 17A.

[0088] FIG. 17C is a schematic partial section view of the device shown in FIG. 17C.

[0089] FIG. 17D is a schematic top view of an example metal panel of the device shown in FIG. 17A.

[0090] FIG. 18A is a top view of the first primary side of the device shown in FIG. 17A.

[0091] FIG. 18B is a bottom view of the second primary side of the device shown in FIG. 18A.

[0092] FIG. 19A is a side perspective view of a phase shifter assembly according to embodiments of the present invention.

[0093] FIG. 19B is a side perspective view of another phase shifter assembly according to embodiments of the present invention.

[0094] FIG. 20A is a rear view of a base station antenna with the radome thereof removed showing a plurality of phase shifter assemblies in pairs aligned parallel with the reflector of the antenna.

[0095] FIG. 20B is a rear view of a base station antenna with the radome thereof removed showing a plurality of phase shifter assemblies aligned perpendicular to the reflector of the antenna according to embodiments of the present invention.

[0096] FIG. 21A is a schematic cross-sectional view of the base station antenna of FIG. 20A.

[0097] FIG. 21B is a schematic cross-sectional view of the base station antenna of FIG. 20B.

[0098] FIG. 22 is a schematic cross-sectional view of the base station antenna of FIG. 20B showing the mechanical linkages for each phase shifter assembly aligned in the same transverse plane according to embodiments of the present invention.

[0099] FIG. 23 is a schematic cross-sectional view of the base station antenna of FIG. 20B including a PING printed circuit board extending perpendicular to the phase shifter assemblies according to embodiments of the present invention.

[00100] FIG. 24 is a schematic block diagram illustrating the electrical connections for the PING printed circuit board of FIG. 23 according to embodiments of the present invention.

[00101] FIG. 25 is a schematic cross-sectional view of the base station antenna of FIG. 20B including a calibration printed circuit board extending perpendicular to the phase shifter assemblies according to embodiments of the present invention.

[00102] FIG. 26A is a perspective view of a phase shifter assembly according to embodiments of the present invention.

[00103] FIG. 26B is a top view of the phase shifter assembly of FIG. 26A.

[00104] FIG. 26C is a side view of the phase shifter assembly of FIG. 26A.

[00105] FIG. 27 is an enlarged bottom perspective view of the phase shifter assembly of FIG. 26A with the bottom phase shifter printed circuit board omitted to show the grounding pin.

[00106] FIG. 28 is a perspective view of another phase shifter assembly according to embodiments of the present invention including two phase shifter assemblies of FIG. 26A.

[00107] FIG. 29A is a top view of the phase shifter assembly of FIG. 28 showing maximum tilt.

[00108] FIG. 29B is a top view of the phase shifter assembly of FIG. 28 showing middle tilt.

[00109] FIG. 29C is a top view of the phase shifter assembly of FIG. 28 showing minimum tilt.

[00110] FIG. 30A is a top perspective view of a mounting base of the phase shifter assembly FIG. 26A having alternative mounting features according to embodiments of the present invention.

[00111] FIG. 30B is a perspective view of the mounting base of FIG. 30A.

[00112] FIG. 31 is a top perspective view of a reflector configured to receive the mounting features shown in FIG. 30A.

[00113] FIG. 32A is a top perspective view of the mounting base of FIG. 30A mounted to the reflector of FIG. 31.

[00114] FIG. 32B and FIG. 32C are enlarged views of the mounting features of the mounting base of FIG. 30A secured to the reflector of FIG. 31.

[00115] FIG. 33 is a perspective view of the entire phase shifter assembly of FIG. 26A mounted on the reflector of FIG. 31.

[00116] FIG. 34A is a top perspective view of a mounting base of the phase shifter assembly FIG. 26A having alternative mounting features according to embodiments of the present invention.

[00117] FIG. 34B is a perspective view of the mounting base of FIG. 34A.

[00118] FIG. 35 is a top perspective view of a reflector configured to receive the mounting features shown in FIG. 34A.

[00119] FIG. 36A is a top perspective view of the mounting base of FIG. 34A mounted to the reflector of FIG. 35.

[00120] FIG. 36B and FIG. 36C are enlarged views of the mounting features of the mounting base of FIG. 34A secured to the reflector of FIG. 35.

[00121] FIG. 37 is a perspective view of the entire phase shifter assembly of FIG. 34A mounted on the reflector of FIG. 35.

DETAILED DESCRIPTION

[00122] Modern base station antennas often include two, three or more linear arrays of radiating elements, where each linear array has an electronically adjustable down tilt. The linear arrays typically include cross-polarized radiating elements, and a separate phase shifter is provided for electronically adjusting the down tilt of the antenna beam for each polarization, so that the antenna may include twice as many phase shifters as linear arrays. Moreover, in many antennas, separate transmit and receive phase shifters are provided so that the transmit and receive radiation patterns may be independently adjusted. This again doubles the number of phase shifters. Thus, it is not uncommon for a base station antenna to have eight, twelve or more phase shifters for applying remote electronic down tilts to the linear arrays. As described above, RET actuators are provided in the antenna that are used to adjust the phase shifters. While the same downtilt is typically applied to the phase shifters for the two different polarizations, allowing a single RET actuator and a single mechanical linkage to be used to adjust the phase shifters for both polarizations, modern base station antennas still often include four, six or more RET actuators (or, alternatively, one or two multi-RET actuators) and associated mechanical linkages.

[00123] In order to change the downtilt angle of an antenna beam generated by a linear array on a base station antenna, a control signal may be transmitted to the antenna that causes a RET actuator associated with the linear array to generate a desired amount of movement in an output member thereof. The movement may comprise, for example, linear movement or rotational movement. A mechanical linkage is used to translate the movement of the output member of the RET actuator to movement of a moveable element of a phase shifter (e.g., a wiper PCB) associated with the linear array. Accordingly, each mechanical linkage may extend between the output member of the RET actuator and the moveable element of the phase shifter. Typically, a mechanical linkage may comprise a series of longitudinally-extending plastic or fiberglass RET rods that are connected by RET linkages that extend in the width and/or depth directions of the antenna. The RET linkages connect the RET rods to each other and/or to the RET actuator or the phase shifter.

[00124] Pursuant to embodiments of the present invention, base station antennas with new phase shifter assemblies are provided that may reduce one or more of hardware, footprint requirements, volumetric space requirements, surface area requirements, mechanical stack up tolerances, and/or costs over conventional phase shifters. Embodiments of the invention may provide improved access to solder joints for service and/or installation ease.

[00125] Embodiments of the present invention will now be discussed in greater detail with reference to the drawings. In some cases, two-part reference numerals are used in the drawings. Herein, elements having such two-part reference numerals may be referred to individually by their full reference numeral (e.g., linear array 120-2) and may be referred to collectively by the first part of their reference numerals (e.g., the linear arrays 120). Like numbers refer to like elements throughout and different embodiments of like elements can be designated using a different number of superscript indicator apostrophes (e.g., 10, 10', 10'').

[00126] FIG. 1A is a perspective view of a RET base station antenna 100 according to embodiments of the present invention. FIG. 1B is a perspective view of the base station antenna 100 with the radome removed to show the four linear arrays of radiating elements that are included in antenna 100.

[00127] As shown in FIG. 1A, the RET base station antenna 100 includes a radome 102, a mounting bracket 104, and a bottom end cap 106. A plurality of input/output ports 110 are mounted in the end cap 106. Coaxial cables (not shown) may be connected between the input/output ports 110 and the RF ports on one or more radios (not shown). These coaxial cables may carry RF signals between the radios and the base station antenna 100. The input/output ports 110 may also include control ports that carry control signals to the base

station antenna **100** from a controller that is located remotely from base station antenna **100**. These control signals may include control signals for electronically changing the tilt angle of the antenna beams generated by the base station antenna **100**.

[00128] For ease of reference, **FIG. 1A** includes a coordinate system that defines the length (**L**), width (**W**) and depth (**D**) axes (or directions) of the base station antenna **100** that may be referred to in the application.

[00129] **FIG. 1B** is a perspective view of the base station antenna of **FIG. 1A** with the radome **102** removed. As shown in **FIG. 1B**, the base station antenna **100** includes two linear arrays **120-1**, **120-2** of low-band radiating elements **122** (*i.e.*, radiating elements that transmit and receive signals in a lower frequency band) and two linear arrays **130-1**, **130-2** of high-band radiating elements **132** (*i.e.*, radiating elements that transmit and receive signals in a higher frequency band). Each of the low-band radiating elements **122** is implemented as a cross-polarized radiating element that includes a first dipole that is oriented at an angle of -45° with respect to the azimuth plane and a second dipole that is oriented at an angle of $+45^\circ$ with respect to the azimuth plane. Similarly, each of the high-band radiating elements **132** is implemented as a cross-polarized radiating element that includes a first dipole that is oriented at an angle of -45° with respect to the azimuth plane and a second dipole that is oriented at an angle of $+45^\circ$ with respect to the azimuth plane. Since cross-polarized radiating elements are provided, each linear array **120-1**, **120-2**, **130-1**, **130-2**, for example, will generate two antenna beams, namely a first antenna beam generated by the -45° dipoles and a second antenna beam generated by the $+45^\circ$ dipoles. The radiating elements **122**, **132** extend forwardly from a backplane **112** which may comprise, for example, a sheet of metal that serves as a ground plane for the radiating elements **122**, **132**.

[00130] **FIG. 2** is a schematic block diagram illustrating various additional components of the RET base station antenna **100** and the electrical connections therebetween. It should be noted that **FIG. 2** does not show the actual location of the various elements on the antenna **100**, but instead is drawn to merely show the electrical transmission paths between the various elements.

[00131] As shown in **FIG. 2**, each input/output port **110** may be connected to a phase shifter **150**. The base station antenna **100** performs duplexing between the transmit and receive sub-bands for each linear array **120**, **130** within the antenna (which allows different downtilts to be applied to the transmit and receive sub-bands), and hence each linear array **120**, **130** includes both a transmit (input) port **110** and a receive (output) port **110**. A first end of each transmit port **110** may be connected to the transmit port of a radio (not

shown) such as a remote radio head. The other end of each transmit port **110** is coupled to a transmit phase shifter **150**. Likewise, a first end of each receive port **110** may be connected to the receive port of a radio (not shown), and the other end of each receive port **110** is coupled to a receive phase shifter **150**. Two transmit ports, two receive ports, two transmit phase shifters and two receive phase shifters are provided for each linear array **120**, **130** to handle the two different polarizations.

[00132] Each transmit phase shifter **150** divides an RF signal input thereto into five sub-components, and applies a phase taper to these sub-components that sets the tilt (elevation) angle of the antenna beam generated by an associated linear array **120**, **130** of radiating elements **122**, **132**. The five outputs of each transmit phase shifter **150** are coupled to five respective duplexers **140** that pass the sub-components of the RF signal output by the transmit phase shifter **150** to five respective sub-arrays of radiating elements **122**, **132**. In the example antenna **100** shown in **FIG. 1A**, **FIG. 1B** and **FIG. 2**, each low-band linear array **120** includes ten low-band radiating elements **122** that are grouped as five sub-arrays of two radiating elements **122** each. Each high-band linear array **130** includes fifteen high-band radiating elements **132** that are grouped as five sub-arrays of three radiating elements **132** each.

[00133] Each sub-array of radiating elements passes received RF signals to a respective one of the duplexers **140**, which in turn route those received RF signals to the respective inputs of an associated receive phase shifter **150**. The receive phase shifter **150** applies a phase taper to each received RF signal input thereto that sets the tilt angle for the receive antenna beam and then combines the received RF signals into a composite RF signal. The output of each receive phase shifter **150** is coupled to a respective receive port **110**.

[00134] While **FIG. 1B** and **FIG. 2** show an antenna having two linear arrays **120** of ten low-band radiating elements **122** each and two linear arrays **130** of fifteen high-band radiating elements **132** each, it will be appreciated that the number of linear arrays **120**, **130** and the number of radiating elements **122**, **132** included in each of the linear array **120**, **130** may be varied. It will also be appreciated that duplexing may be done in the radios instead of in the antenna **100**, that the number(s) of radiating elements **122**, **132** per sub-array may be varied, that different types of radiating elements may be used (including single polarization radiating elements) and that numerous other changes may be made to the base station antenna **100** without departing from the scope of the present invention.

[00135] As can be seen from **FIG. 2**, the base station antenna **100** may include a total of sixteen phase shifters **150**. While the two transmit phase shifters **150** for each linear

array **120, 130** (*i.e.*, one transmit phase shifter **150** for each polarization) may not need to be controlled independently (and the same is true with respect to the two receive phase shifters **150** for each linear array **120, 130**), there still are eight sets of two phase shifters **150** each that should be independently controllable.

[00136] Each phase shifter **150** shown in **FIG. 2** may be implemented, for example, as a rotating wiper phase shifter. The phase shifts imparted by a phase shifter **150** to each sub-component of an RF signal may be controlled by a mechanical positioning system that physically changes the position of the rotating wiper of each phase shifter **150**, as will be explained with reference to **FIG. 3**. It will be appreciated that other types of phase shifters may be used instead rotating wiper phase shifters such as, for example, trombone phase shifters, sliding dielectric phase shifters and the like.

[00137] Referring now to **FIGS. 3A, 3B, 4A, 4B** and **5**, a wiper phase shifter assembly **200** is illustrated that may be used to implement, for example, two of the phase shifters **150** of **FIG. 2**. The wiper phase shifter assembly **200** includes first and second phase shifters **202A, 202B**. To be clear, in the description, the two phase shifters **202A, 202B** may be described as each being transmit phase shifters that have one input **230** and five outputs **240**. It will be appreciated that if the phase shifters **202A, 202B** are instead used as receive phase shifters then the terminology changes, because when used as receive phase shifters there are five inputs and a single output.

[00138] As shown in **FIG. 3A**, the phase shifter assembly **200** includes a single main (stationary) printed circuit board **210** (the term "printed circuit board" can be interchangeably referred to as "PCB" herein) that is double-sided providing different phase shifters **202A, 202B**, respectively, one on each side of the main PCB **210**. The main PCB **210** and can have a primary first side **210A** (*i.e.*, a primary first surface) with a plurality of transmission lines **212, 214, 216** and a primary opposing second side (*i.e.*, a primary second surface) **210B** with transmission lines **212, 214, 216**. The dual phase shifter **200** also includes a rotatable wiper **220**, shown as comprising first and second rotatable wiper printed circuit boards **220A, 220B** that are each rotatably coupled to the single respective main printed circuit board **210**, one of the wiper printed circuit boards on one side of the main PCB and the other parallel with an on the opposing side of the main PCB, with a ground plane **210G** (**FIG. 5**) of the main PCB **210** therebetween. The wiper **220** can be pivotally mounted on the main printed circuit board **210** at a pivot joint provided by a pivot pin **222** so that both wiper printed circuit boards **220A, 220B** rotate in concert in a desired direction relative to the main PCB **210**.

[00139] As shown, in some embodiments, the main PCB **210** can have a perimeter **210p** which can include one arcuate side and three straight linear sides. The outer end of the wiper **220e** can extend outside of and about the arcuate side.

[00140] Referring to **FIGS. 3B, 5 and 6**, the wiper **220** can have a body with a closed outer end **220e** that couples first and second wiper arms **221A, 221B** that hold respective first and second wiper printed circuit boards **220A, 220B**. The wiper **220** can have an attachment link **223** that can couple to a bracket **224** that connects to a drive shaft **228** of a mechanical linkage allowing the RET directional input for phase shift adjustment. Thus, the parallel wiper arms **221A, 221B** may be joined together at their outer or distal ends via a bracket **224**. However, the wiper arms **221A, 221B** may be decoupled from each other and comprise different attachment links to connect to the same or a different drive shaft (not shown). As shown, the protruding attachment link **223** is orthogonal to the arms **221A, 221B** and also extends outward from each of the arms **221A, 221B**. However, the attachment link **223**, where used, can protrude off a single one of the arms or a different attachment configuration can be used.

[00141] The position of each rotatable wiper printed circuit boards **220A, 220B** relative to the main printed circuit board **210** is controlled by the position of a drive shaft **228** (partially shown in **FIG. 6**), the end of which may constitute one end of a mechanical linkage. The other end of the mechanical linkage (not shown) may be coupled to an output member of a RET actuator.

[00142] As discussed above, each side **210A, 210B** of the main printed circuit board **210**, **210a** includes transmission line traces **212, 214**. The transmission line traces **212, 214** can be curvilinear and include arcuate segments. In some embodiments, the transmission line traces **212, 214** may be disposed in a serpentine pattern to achieve a longer effective length. In the example illustrated in **FIGS. 3A, 3B, 4A, 4B, and 6**, for example, there are two curvilinear transmission lines with arcuate segment traces **212, 214** on each side **210A, 210B** of the main printed circuit board **210**. The first transmission line trace **212** can be disposed along an outer perimeter of one side of the printed circuit board **210** and the second transmission line trace **214** can be disposed more medially to the main PCB **210** typically on a shorter radius concentrically within the outer transmission line trace **212**. A third transmission line trace **216** on each side **210A, 210B** of the main printed circuit board **210** connects an input pad **230** to an output pad **240** that is not required to be subjected to an adjustable phase shift.

[00143] An arcuate segment of the first transmission line **212** can reside adjacent the arcuate side of the main PCB **210**.

[00144] Referring to **FIGS. 3A** and **3B**, the main PCB **210** includes one or more input traces **232** leading from the input pad **230** near an edge of the main printed circuit board **210** to the position where the pivot pin **222** is located. RF signals on a respective input trace **232** are coupled to a transmission line trace on a corresponding wiper printed circuit board **220A**, **220B**, typically via a capacitive connection. The transmission line trace on the respective wiper printed circuit board **220A**, **220B** may split into a plurality of (*i.e.*, two) secondary transmission line traces (not shown). The RF signals can be capacitively coupled from the secondary transmission line traces on the wiper printed circuit board **220A**, **220B** to the transmission line traces **212**, **214** on the main printed circuit board. Each end of each transmission line trace **212**, **214** may be coupled to a respective output pad **240**. A coaxial cable **260** or other RF transmission line component may be connected to input pad **230**. A respective coaxial cable **270** or other RF transmission line component may be connected to each respective output pad **240**. As the wiper printed circuit boards **220A**, **220B** move, an electrical path length from the input pad **230** of a respective phase shifter **202A**, **202B** to each corresponding output pad **240** changes.

[00145] For example, as each wiper printed circuit board **220A**, **220B** moves (in concert) to the left it shortens the electrical length of the path from a corresponding input pad **230** to a corresponding output pad **240** connected to the left side of transmission line trace **212** (which connects to a first sub-array of radiating elements), while the electrical length from the input pad **230** to the output pad **240** connected to the right side of transmission line trace **212** (which connects to a second sub-array of radiating elements) increases by a corresponding amount. These changes in path lengths result in phase shifts to the signals received at the output pads **240** connected to transmission line trace **212** relative to, for example, the output pad **240** connected to transmission line trace **216**.

[00146] One or more of the transmission lines **212**, **214**, **216** on each side **210A**, **210B** of the main PCB **210** can be aligned in the X and Y direction, *i.e.*, have a duplicate geometry that is symmetrically arranged, one above the other and spaced apart from each other the thickness of the main PCB **210**.

[00147] In some embodiments, corresponding pairs of pads **230** and/or **240** on each side **210A**, **210B** of the main PCB **210** for each phase shifter **202A**, **202B** can be aligned in a Y direction and offset in an X direction. Thus, as shown in **FIGS. 3A** and **3B** and **FIGS. 4A** and **4B**, one input pad **230** on the first primary surface/side of the main PCB **210A** (measured

from a centerline thereof) can reside a distance x_1 from a bottom edge of the main PCB **210** and the other input pad **230** on the other primary surface/side of the main PCB **210B** can reside a distance x_2 (also measured from the centerline thereof) from the bottom edge of the main PCB **210**. This can allow pairs of the coaxial cables **260** and **270** that connect to input/output pads **230**, **240** on each side of the main PCB to reside laterally adjacent each other rather than stacked one above the other for connection to the main PCB **210**. The end portions **260e**, **270e** of the respective cables **260**, **270** that engage the pads **230/240** can extend in a straight linear configuration forward over a respective pad **230/240** without interference between adjacent cables on the different sides **210A**, **210B** of the main PCB **210**.

[00148] Referring to FIG. 4A, neighboring pairs of cables **260p₁**, **260p₂** can be separated by a longitudinally extending gap **260g**. The gap **260g** can have an X direction dimension that is greater than an X direction dimension of a gap **260g** between each cable **260₁**, **260₂** of a respective cable pair **260p**.

[00149] Depending on the thickness of the main PCB **210**, different cable connection and/or PCB interfaces can be used. Other example embodiments will be discussed below.

[00150] Referring to FIG. 5, the main PCB **210** can comprise a ground plane **210G** sandwiched between first and second dielectric layers **211** and with the conductive transmission lines **212**, **214**, **216** and pads **230**, **240** provided as conductive trace layers **213** on outer surfaces of the first and second dielectric layers **211**. In some embodiments, the main PCB **210** can have multiple layers, with one or more copper layers. Each respective copper layer can be sandwiched between dielectric material layers. In some embodiments, the main PCB **210** can comprise at least five layers (*i.e.*, five, six, seven, eight, nine, ten or even more layers) and can have a thickness in a range of about 2 mm to about 10 mm, more typically a range of about 3 mm to about 5 mm.

[00151] Referring to FIGS. 3A, 3B, 7A and 7B, the phase shifter assembly **200** can include at least one transition block connector **325** that can reside outside a boundary of the main PCB **210** and can couple pairs **1260p** of larger cables **1260₁**, **1260₂** to corresponding pairs **260p** of smaller outer diameter (and shorter length) coaxial cables **260₁**, **260₂**. The centerlines of the first and second larger cables **1260₁**, **1260₂** can be closely spaced from each other, optionally offset a distance **d1** in a depth (Z direction) and a distance **d2** in the X direction. The transition block connector **325** can allow a suitable mechanical connection for cable size reduction to avoid physical interference at the main PCB **210**. The transition block connector **325** can be configured to frictionally engage each of the two pairs of cables **260p**, **1260p**.

[00152] FIGS. 8A, 8B, 9A, 9B and 10A illustrate another embodiment of a phase shifter assembly 200. In this embodiment, one or more connector block assemblies 330 can be used to provide the interface connection of the coaxial cables 260, 270 to the main PCB 210. Each connector block assembly 330 can be configured to hold a plurality of pairs of cables 260p, 270p. The connector block assembly 330 can be configured to hold each pair of cables 260p, 270p stacked in the Z direction (one above another in the orientation of the main PCB 210 shown) and aligned in the X and Y directions. The connector block assembly 330 can hold a plurality of cables 260/270 in parallel rows, with one set of rows adjacent the first primary side 210A and a second set of rows adjacent the second primary side 210B to route and support respective coaxial cables 260/270 to the first and second primary sides of the main PCB 210.

[00153] The cable connector block assembly 330 may help restrict undesired movement of the antenna RF cables, and may strengthen electrical connections with the antenna RF cables, thereby improving performance of the associated base station antenna.

[00154] Referring to FIG. 10B, an example cable connector block assembly 330 is shown. The assembly 330 can include a plurality of cable retention clips 331. Each clip 331 can define a longitudinally extending channel or recess 331r that is sized and configured to receive and retain a respective RF cable 260 or 270. The clips 331 can hold the cables 260 or 270 in place during a soldering process and provide strain relief when a tower supporting a base station antenna that includes the cable connector block assembly 330 is subject to wind or other vibrations.

[00155] The clips 331 may be on a first end portion 332f of a connector block 332, further away from the main PCB 210 than a second end of the connector block 332. The cable connector block assembly 330 can also include metal members 330M in recessed portions of the connector block 332. A first set of the metal members 330M may be adjacent the clips 331, and a second set of the metal members 330M may be on the second end portion 332s of the connector block 332. FIG. 10B illustrates that an adhesive layer 334 may optionally be provided between the connector block 332 and the main PCB 210. The shape of, and openings 334a in, the adhesive layer 334 may conform to the main PCB 210.

[00156] The connector block assembly 330 can comprise one or more protruding portions 336 that can extend through respective openings 209 in the main PCB 210. The adhesive layer 334 and/or the protruding portion(s) 336 may help to keep the connector block 332 in a stationary position on the main PCB 210. The main PCB 210 may further

include apertures **234, 235** that are configured to receive protruding portions of the different sets of metals **330M**.

[00157] **FIG. 10B** also illustrates that each of the cables **270** may include four different portions: (1) a center conductor **270C**, (2) a dielectric separator **270D**, (3) a ground sleeve **270G**, and (4) an insulating cover **270I**. In some embodiments, the center conductor **270C** may be referred to as an "inner" conductor or a "lead" conductor. The connector block assembly **330** can ground the cables **260, 270** directly to the main PCB **210** using the metal members **330M**.

[00158] Although three pairs of cables **270p** are held by each connector block assembly **330**, three cables **260/270** facing the first side of the main PCB **210A** and three cables **260/270** facing a second side of the main PCB **210B**, as illustrated in **FIGS. 10A and 10B**, the connector block **332** may be configured to receive more or fewer of the cables **270** and/or **260**. For example, the connector block **332** may be configured to receive one, two, four, five, six, seven, eight, or more of the cables **270** and/or **260**. For additional details of example connector block assemblies, *see* co-pending U.S. Patent Application Serial No. 16/052,844, the contents of which are hereby incorporated by reference as if recited in full herein.

[00159] Referring now to **FIGS. 11A, 11B, 11C, 12 and 13**, another embodiment of a phase shifter assembly **200** is shown. In this embodiment, center conductors of pairs of cables **260p, 270p** can each have an end portion **260e, 270e** that is bent toward the other, across a thickness of the main PCB **210**, to have a first terminal segment **261, 271** that merges into an adjacent second terminal segment **262, 272** configured to place the main body of the cable **260, 270** a distance away from the main PCB **210** with the second segment **262, 272** being planar and residing closer to the main PCB **210**. Referring to **FIG. 13**, the second terminal segments **262, 272** can be parallel to the primary sides/surfaces **210A, 210B** of the main PCB **210** and can reside at an angle β measured from an axially extending centerline (C/L) of the first terminal segment **261, 271** and/or primary body of the cable **260, 270**. The angle β can be between 45 degrees and 90 degrees, more typically between 60-90 degrees. The cables **260, 270** can be provided for installation with the ends pre-bent or a tool may be provided to allow a technician to form the desired bend. The bent terminal end segments can eliminate any requirement to use offset traces or pads **230, 240** and each primary side **210A, 210B** can be the mirror image of the other.

[00160] **FIGS. 14A and 14B** illustrate that the main PCB **210** can have a perimeter **210p** that is configured to provide offset pad traces. The main PCB **210** can have an arcuate

slot 277 that allows the wiper 220 to rotate relative to the pivot joint 222p. The pads 230, 240 on the first primary side 210A can reside on one side of the slot 277 (shown as above the slot) and the pads 230, 240 on the other primary side 210B can reside offset from those on the first primary side, shown on an opposing side of the slot 277 (shown as below the slot). The main PCB 210 can have a perimeter 210p that is rectangular with a pair of long sides 210l and a pair of shorter sides 210s. The longer sides 210l can be in the Y dimension. The slot 277 can reside adjacent the arcuate segment of the first transmission line 212, closer to an outer edge of the perimeter of the main PCB 210 than the first transmission line 212. The pads 230, 240 can reside on outer edge portions of the short sides 210s. This configuration can extend the traces of the pads 230, 240 past the wiper 220.

[00161] FIGS. 15A and 15B illustrate another embodiment of the main PCB 210 that can provide offset pads 230, 240 and corresponding connection traces on each primary side 210A, 210B thereof. The primary transmission lines 212, 214 can have the same position and configuration on each primary side 210A, 210B of the main PCB 210. The perimeter 210p of the main PCB 210 can have a pair of long sides 210l and a pair of shorter sides 210s. One of the longer sides 210l can be arcuate. The arcuate segment of the first transmission line 212 can reside adjacent the arcuate (long) side of the main PCB 210. On one primary side of the main PCB 210, shown as the first primary side 210A, the terminal pads 230, 240 can reside closer to the arcuate side of the perimeter 210p of the main PCB 210 than the terminal pads 230, 240 on the opposing primary side, shown as the second primary side 210B. The terminal pads 230, 240 on the second primary side 210B can reside further away from the pivot point 222p than the pads 230, 240 on the first primary side 210A. The main PCB 210 can have a perimeter 210p with an increased length in the X direction relative to other shapes and to place the pivot 222p closer to a medial location of the main PCB 210, in the X and Y directions, relative to the main PCB 210 shown in other figures herein.

[00162] FIGS. 16A and 16B illustrate another embodiment of the main PCB 210 that can provide input and/or output pads 230, 240 and corresponding connection traces on each primary side 210A, 210B. As shown, the main PCB 210 is configured with pads 230, 240 on the top and bottom rather than on the sides of the main PCB 210. The top and bottom can be long sides 210l of the main PCB 210. The main PCB 210 can include an arcuate slot 277 that is spaced apart but adjacent the top side 210t. The top 210t and the bottom 210b can have a straight linear shape. The first side 210A and the second side 210B can place a plurality of pads 230, 240 on the top 210t and a plurality of pads 240 on the bottom 210b. The pads on

the top **210t** can reside above the slot **277**. The pads **230**, **240** on the bottom **210b** can reside below the slot **277**. The input pad **230** on the first side **210A** can reside adjacent a top corner **210tc** and the input pad on the second side **210B** can reside adjacent a bottom corner **210bc**. The input pad **230** on the first primary side **210A** can be an outermost pad in the top corner **210tc**. The input pad **230** on the bottom corner **210bc** can be an innermost pad in the bottom corner. The pivot point **222p** can reside closer to the bottom **210b** than the top **210t**. The slot **277** can allow the wiper **220** to rotate while held by a pin **222** (FIG. 3A) at the pivot point **222p**.

[00163] Turning now to FIGS. 17A-17C, 18A and 18B, yet another embodiment of a phase shifter assembly **200'** is shown. In this embodiment, first and second **210₁₋₁**, **210₁₋₂** co-planar laterally spaced apart and adjacent main PCBs **210** reside on one primary side **1210A** of a plate (e.g., panel) **1210** (FIG. 17A, 18A) and first **210₂₋₁** and second **210₂₋₂** co-planar laterally spaced apart adjacent main PCBs **210** reside on an opposing primary side **1210B** of the plate **1210** (FIGS. 17B, 18B). The main PCBs **210** can each abut the plate **1210**. The main PCBs **210** can each be attached mechanically or adhesively to the plate **1210**. A pivot pin **222** can extend through an aligned pair **210pr** of first and second main PCBs **210₁**, **210₂** and an aperture **1210a** in the plate **1210** (FIG. 17D) to allow the pivot arms **221A**, **221B** to rotate about the pair of main PCBs **210**.

[00164] The plate **1210** can be a metal plate. The plate **1210** can comprise aluminum, stainless steel, other metals or metal alloys. The plate **1210** can comprise first and second slots **1212**. The slots **1212** can be arcuate and reside adjacent each other along a medial portion of the plate **1210**. The phase shifter assembly **200'** can include a wiper **220** with pairs of the wiper arms **221A**, **221B** configured to rotate in concert about aligned and parallel pairs of the main PCBs **210₁**, **210₂**. As shown by FIG. 17C, aligned parallel pairs of the main PCBs **210₁**, **210₂** can reside one on each primary side **1210A**, **1210B** of the plate **1210**. The main PCBs **210₁**, **210₂** can each be single sided with the conductive traces **212**, **214**, **216** and pads **230**, **240** on only one primary side/surface **210A** and oriented to face away from the plate **1210**.

[00165] As shown in FIG. 17D, the first and second arcuate slots reside at a medial location of the plate **1210** and the first slot **1212** has a first radius of curvature **R1** and the second slot has a second radius of curvature **R2**. **R1** can be equal to **R2** but oriented to provide opposing rather than concentric arc segments.

[00166] As shown in FIGS. 17A and 17B, the perimeter of the main PCB **210** can have an arcuate side that faces an arcuate side of the adjacent PCB **210**. The pivot pins **222** can be

aligned in the Y direction and spaced apart in the X direction. As shown in FIGS. 17A, 17B and 17D, pairs of the conductors 260p, 270p can be held in channels 1210c coupled to or formed by the plate 1210 to be able to support and/or route the cables 260, 270 to couple to respective pads 230, 240 of the aligned first and second (shown as upper and lower) PCBs 210₁, 210₂. The plate 1210 can have (four) spaced apart open spaces 1213 residing between an outer perimeter 1210p thereof and the slots 1212 as shown. The wiper arms 221A, 221B can include an open or closed end segment facing away from the pivot pin 222 and a protruding attachment link 223 that is orthogonal to the arms 221A, 221B.

[00167] Thus, referring to FIGS. 18A and 18B, the phase shifter assembly 200' can include four printed circuit boards 210 that can be identified as first 210₁₋₁, second 210₂₋₁, third 210₁₋₂ and fourth 210₂₋₁ main printed circuit boards 210, each having a perimeter 210p. The perimeter 210p can have a pair of long sides 210l and a pair of short sides 210s, with one long side defining a bottom 210b and one long side defining a top 210t. The tops 210t of the first 210₁₋₁ and third 210₁₋₂ printed circuit boards 210 can be arcuate and reside adjacent each other with the first and second slots 1212 therebetween. The tops 210t of the second 210₂₋₁ and fourth 210₂₋₂ printed circuit boards can be arcuate and reside adjacent each other with the first and second slots 1212 therebetween.

[00168] The plate 1210 can couple to the transition block connector 325 (FIGS. 7A and 7B) and/or the transition block connector 325 can be integrated with the plate 1210 as a unitary member. The transition block connector 325 can define at least part of the cable channels 1210c (FIG 17D).

[00169] The plate 1210 can couple to the connector block assembly 330 (FIGS. 8A and 8B) or these components can be integrated to form a unitary member. The transition block connector 325 can define at least part of the cable channels 1210c (FIG 17D).

[00170] The phase shifter assembly 200, 200' can be oriented in a base station antenna housing either vertically or horizontally.

[00171] Referring now to FIGS. 19A-25, additional embodiments of the present invention are illustrated. FIG. 19A is a side perspective view of a phase shifter assembly 300 having a pair of phase shifters extending parallel to each other according to embodiments of the present invention. FIG. 19B is a side perspective view of another phase shifter assembly 300' according to embodiments of the present invention that has a similar construction to the phase shifter assembly 300 of FIG. 19A. The phase shifter assemblies 300, 300' may have many of the same or similar components as described above with respect to phase shifter assemblies 200, 200'.

[00172] As shown in **FIGS. 19A-19B**, the phase shifter assemblies **300, 300'** have a pair of main PCBs **210A, 210B**. Each main PCB **210A, 210B** resides on a respective plate (*e.g.*, panel) **1210A, 1210B**. The plates **1210A, 1210B** are arranged back-to-back and extend parallel to each other. The main PCBs **210A, 210B** can each be attached mechanically or adhesively to their respective plates **1210A, 1210B**. Similar to embodiments discussed above, a pivot pin **222** (or a pair of pivot pins **222**) allows wiper arms **221A, 221B** to rotate about the pair of main PCBs **210A, 210B**.

[00173] The wipers **220A, 220B** can have a body with a closed outer end **220e**. The ends **220e** of the wipers **220A, 220B** can have an attachment link **223** that can be coupled to a bracket **224** that connects both wipers **220A, 220B** to a drive shaft **228** of a mechanical linkage. The parallel wipers **220A, 220B** may be joined together at their outer or distal ends **220e** via the bracket **224**. As shown in **FIGS. 19A-19B**, the plates **1210A, 1210B** (and main PCBs **210A, 210B**) extend parallel to each other.

[00174] As discussed above, the radiating elements **122, 132** of the base station antenna **100** extend forwardly from a backplane **112** (*see, e.g., FIG. 1B*). In some embodiments, as will be discussed in further detail below, the phase shifter assemblies **300, 300'** may be oriented in the base station antenna **100** such that the phase shifter assemblies **300, 300'** extend rearwardly from the backplane **112** (*e.g.*, a reflector **305** of the antenna **100**). The reflector **305** defines a plane that is oriented typically parallel with the front of the antenna **100** (the side of the antenna that is opposite the mounting bracket **104** as shown in **FIG. 1A**). Thus, the phase shifter assemblies **300, 300'** (*i.e.*, the plates **1210A, 1210B** and main PCBs **210A, 210B**) may be aligned substantially perpendicular to the plane defined by the reflector **305** of the antenna **100**. Herein, a phase shifter assembly is considered to be oriented perpendicular to the plane defined by the reflector, if the main surfaces of the one or more main PCBs included in the phase shifter assembly extend perpendicular to the plane defined by the reflector. As used herein, "substantially perpendicular" means at an angle of 90 degrees to a given line, plane, or surface (± 10 degrees).

[00175] Still referring to **FIGS. 19A-19B**, in some embodiments, the phase shifter assemblies **300, 300'** may include one or more mounting flanges **302**. The mounting flanges **302** may be coupled to or integral with the plates **1210A, 1210B** of the phase shifter assemblies **300, 300'**. In some embodiments, the mounting flanges **302** may be configured to mount a respective phase shifter assembly **300, 300'** (*i.e.*, the plates **1210A, 1210B**) to the reflector **305** of the antenna **100**. In some embodiments, the mounting flanges **302** may be

configured to mount the phase shifter assembly **300, 300'** to a support member **304** (e.g., a tray) (see, e.g., **FIG. 21B**). The mounting flanges **302** are configured such that, when the phase shifter assemblies **300, 300'** are mounted to the reflector **305** or support member **304**, each phase shifter assembly **300, 300'** extends rearwardly from the reflector **305** or support member **304**. In other words, the mounting flanges **302** are configured such that the rearwardly extending phase shifter assemblies **300, 300'** (i.e., the plates **1210A, 1210B**) are oriented substantially perpendicular to the plane defined by the reflector **305** or support member **304** when mounted thereon.

[00176] According to some embodiments of the present invention, the rearwardly extending phase shifter assemblies **300, 300'** may provide for reduced manufacturing costs and/or improved performance, for example, when compared to assemblies that are aligned parallel to the reflector **305** of the antenna **100**. For example, in some embodiments, the rearwardly extending phase shifter assemblies **300, 300'** of the present invention may use a single bracket **224** to couple both wipers **220A, 220B** of the phase shifter assembly **300, 300'** to the drive shaft **228** rather than using two separate pins for each wiper **220A, 220B** which are typically used for phase shifter assemblies that are aligned in parallel with the reflector **305**. This reduction in the number of parts may provide for a reduction in manufacturing costs for base station antennas **100** having the rearwardly extending phase shifter assemblies **300, 300'** of the present invention. In addition, the use of a single bracket **224** for the phase shifter assemblies **300, 300'** of the present invention allows for the wipers **220A, 220B** to rotate in concert which may provide for better accuracy in phase adjustments of the base station antenna **100**.

[00177] In some embodiments, each phase shifter assembly **300, 300'** may further comprise rod supports **229**. The rod supports **229** may be configured to couple the plates **1210A, 1210B** together. The rod supports **229** may also provide additional support to the drive shaft **228** and help maintain the drive shaft **228** aligned within the ends **220e** of the wipers **220A, 220B**.

[00178] Referring now to **FIGS. 20A-20B** and **21A-21B**, according to some embodiments of the present invention, when the phase shifter assemblies **300, 300'** of the present invention are oriented substantially perpendicular to the plane defined by the reflector **305**, this orientation may allow for more phase shifter assemblies **300, 300'** to fit within the base station antenna **100** without having to increase the size of the antenna **100**.

[00179] **FIG. 20A** is a rear view of a base station antenna **100** with the radome **102** thereof removed showing a plurality of phase shifter assemblies **160a, 160b** in pairs and oriented

parallel to the plane defined by the reflector **305** of the antenna **100**. **FIG. 20B** is a rear view of a base station antenna **100** with the radome **102** thereof removed showing a plurality of phase shifter assemblies **300, 300'** oriented substantially perpendicular to the plane defined by the reflector **305** of the antenna **100** according to embodiments of the present invention. **FIG. 21A** is a schematic cross-sectional view of a base station antenna **100** showing the phase shifter assemblies **160a, 160b** aligned parallel to the reflector **305** and stacked on top of each other (*i.e.*, extending rearwardly from the reflector **305**). **FIG. 21B** is a schematic cross-sectional view of a base station antenna **100** showing an array of rearwardly extending phase shifter assemblies **300, 300'** (*i.e.*, oriented substantially perpendicular to the reflector **305**) according to embodiments of the present invention.

[00180] Referring to **FIGS. 20A-20B**, **FIG. 20A** shows the interior of a base station antenna **100** having four high band phase shifter assemblies **160a₁, 160a₂, 160a₃, 160a₄** and two low band phase shifter assemblies **160b₁, 160b₂**. The phase shifter assemblies **160a₁, 160a₂, 160a₃, 160a₄, 160b₁, 160b₂** are arranged in pairs and oriented parallel with the reflector **305**. As shown in **FIG. 20B**, in some embodiments, a base station antenna **100** may have two, three, four times, or more rearwardly extending phase shifter assemblies **300, 300'** within a similarly sized antenna **100** when the phase shifter assemblies **300, 300'** are mounted perpendicular to the plane defined by the reflector **305**. For example, in some embodiments, the base station antenna **100** may have 2, 4, 6, 8, 10, 12, 14, 16, 18, 20, 22, 24, 26, 28, 30 or more phase shifter assemblies **300, 300'** mounted perpendicularly to the reflector **305**. The orientation of the assemblies **300, 300'** of the present invention allows for a more efficient arrangement of mechanical linkages within the antenna **100**. Thus, more phase shifter assemblies **300, 300'** may fit in the additional space within an antenna **100** that is no longer being occupied by the mechanical linkages. As shown in **FIG. 20B**, in some embodiments, the base station antenna **100** may have twenty-six phase shifter assemblies **300, 300'** (*e.g.*, twenty high band assemblies **300** and six low band phase shifter assemblies **300'**).

[00181] As shown in **FIGS. 21A-21B**, the phase shifter assemblies **300, 300'** of the present invention may eliminate the need to stack phase shifter assemblies **160a, 160b** within a base station antenna **100** in planes parallel to the reflector **305**. The rearwardly extending phase shifter assemblies **300, 300'** of the present invention may allow for a more efficient arrangement and organization (*e.g.*, mechanical linkages) within the base station antenna **100**, thereby creating more space within the antenna **100**. As compared to traditional stacking of phase shifter assemblies **160a, 160b** within a base station antenna **100**, which may lead to design issues, such as, for example, spacing issues within the base station antenna **100** and/or

complex mechanical linkage designs, which can lead to more parts and/or higher manufacturing costs.

[00182] The phase shifter assemblies **300, 300'** of the present invention may help to alleviate these issues. For example, **FIG. 21A** shows phase shifter assemblies **160a, 160b** aligned parallel with the reflector **305** and stacked on top of each other (rearwardly extending from the reflector **305**) within a base station antenna **100**. The base station antenna **100** shown in **FIG. 21B**, according to some embodiments, illustrates rearwardly extending phase shifter assemblies **300, 300'** oriented such that the assemblies **300, 300'** are perpendicular to the reflector **305** which may fit more phase shifter assemblies **300, 300'** within the same space as the stacked phase shifter assemblies **160a, 160b** that are oriented parallel to the reflector **305** (**FIG. 21A**). Thus, as shown in **FIG. 21B**, the phase shifter assemblies **300, 300'** of the present invention may help to eliminate the need to stack phase shifter assemblies **160a, 160b** within the base station antenna **100** in planes parallel to the reflector **305**, thereby reducing spacing issues and allowing for less complex mechanical linkage designs.

[00183] As shown in **FIG. 22**, in some embodiments, the rearwardly extending phase shifter assemblies **300, 300'** of the present invention may have all of the mechanical linkages (*e.g.*, attached to drive shafts **228**) aligned along the same transverse plane (**P**). Having all the mechanical linkages aligned along the same plane (**P**) will allow for simple straight linkages to be utilized within the base station antenna **100**, which will help to simplify mechanical linkage designs within the antenna **100**.

[00184] In some embodiments, the rearwardly extending phase shifter assemblies **300, 300'** of the present invention may be formed into a modular design. For example, the phase shifter assemblies **300, 300'** may be subdivided into smaller arrays of phase shifter assemblies **350**, *i.e.*, "modules." In some embodiments, an array of phase shifters assemblies **350** may be built/assembled separately from the base station antenna **100** as a module (*e.g.*, on a support member **304**) and then added to the base station antenna **100** later in the assembly process. According to some embodiments, the modular design of the present invention may allow for the phase shifter assemblies **300, 300'** to be built and tested prior to being integrated into the base station antenna **100**. For example, in some embodiments, the each phase shifter assembly **300, 300'** may be mounted on a support member via the mounting flanges **302** such that the phase shifter assemblies **300, 300'** are oriented substantially perpendicularly to a plane defined by the support member **304**. The support member **304** with the array of phase shifter assemblies **300, 300'** mounted thereon may then

be mounted within the base station antenna **100**. This modular design may allow for multiple phase shifter assemblies **300, 300'** of the present invention to be integrated into a base station antenna **100** as one unit, which may provide for a more efficient and cost effective way to assemble a base station antenna **100**.

[00185] Referring now to **FIG. 23**, according to some embodiments of the present invention, a base station antenna **100** may have a PING printed circuit board (PCB) **310** that extends perpendicular to the phase shifter assemblies **300, 300'**.

[00186] As the number of RF ports at the bottom of an antenna continue to increase, it is becoming harder and harder for technicians to install base station antennas. The increased numbers of RF ports are leading to technicians more frequently crisscrossing cables between antennas and radio. Currently, most antennas typically include color coding located near the RF ports to help guide technicians (with visual inspection) make the correct cable connections.

[00187] To further reduce the frequency of crisscrossed cable connections, the Antenna Interface Standards Group ("AISG") recently released a new standard that would require every RF port of a new base station antenna **100** have the ability to receive a PING signal ("AISG PING signal"). *See, e.g.*, AISG Standard v3.0 (November 5, 2018). Incorporating a PING printed circuit board **310** within the base station antenna **100** will allow an operator to send an AISG PING signal from a radio into the antenna **100** for a specific RF port (*see, e.g.*, **FIG. 24**). In response to the AISG PING signal, identifying information about the specific RF port will be returned, *e.g.*, information that the RF port is a low band port with a -45 degree polarization. An installer will be able to use this identifying information to confirm the correct cable connections are being made.

[00188] Grouping an array of phase shifters **150** in a single location according to embodiments of the present invention, *e.g.*, using the modular design of the phase shifter assemblies **300, 300'** discussed above, will allow for the implementation of a PING feature into a base station antenna **100** in a cost effective matter. As shown in **FIG. 23**, a plurality of phase shifter assemblies **300, 300'** may be serially connected to a PING printed circuit board (PCB) **310**. The PING PCB **310** may be mounted on the reflector **305** or support member **304** with the rearwardly extending phase shifter assemblies **300, 300'**. In some embodiments, each phase shifter **150** may be coupled to the PING PCB **310** through a respective blind mated or cabled connection **360**. In a cabled connection **360**, having the PING PCB **310** extending perpendicularly to the rearwardly extending phase shifter assemblies **300, 300'** will allow for shorter cables to be used. In operation, the PING

PCB **310** selectively-distributes an AISG PING signal from a RET controller **320** to each phase shifter **150** as desired to implement the AISG PING feature.

[00189] **FIG. 24** is a schematic block diagram illustrating an exemplary electrical connection for the PING PCB **310** according to embodiments of the present invention. As shown in **FIG. 24**, the PING PCB **310** includes a multiplexer. In a typical base station antenna **100**, *e.g.*, where the phase shifter assemblies **160a**, **160b** are oriented parallel to the reflector **305**, the PING PCB **310** is most likely located at an end of the antenna **100**. This layout within an antenna **100** requires long cables to connect the phase shifter assemblies **160a**, **160b** to the multiplexer of the PING PCB **310**. In some embodiments of the present invention, extending the PING PCB **310** perpendicularly to the rearwardly extending phase shifter assemblies **300**, **300'** allows for shorter cables to be used (*e.g.*, with a cabled connection **360**), which may help to enhance performance, such as, for example, mitigating signal loss, as well as, reducing the cost and weight of the antenna **100**.

[00190] Referring now to **FIG. 25**, in some embodiments, a base station antenna **100** may have a calibration PCB **330** extending perpendicularly to the phase shifter assemblies **300**, **300'**. In order to reduce the impact of amplitude and phase variations, beam-forming antennas may include a calibration circuit that samples the RF signals and passes these samples back to the radio. The calibration circuit may comprise a plurality of directional couplers, each of which is configured to tap RF energy from a respective one of the RF transmission paths that extend between the RF ports and the respective columns of radiating elements, as well as a calibration combiner that is used to combine the RF energy tapped off of each of these RF transmission paths. The output of the calibration combiner is coupled to a calibration port on the antenna, which in turn is coupled back to the radio. The radio may use the samples of each RF signal to determine the relative amplitude and/or phase variations along each transmission path, and may then adjust the applied amplitude and phase weights to account for these variations.

[00191] Typically, the calibration printed circuit board (PCB) **330** is located at an end of the antenna **100**. Similar to the PING PCB **310** discussed above, this configuration requires long cables to be routed from each phase shifter **150** to the calibration PCB **330**. For example, a Nokia massive MIMO style calibration board would require 32 long cables routed from the phase shifters **150** (typically located in the center of the antenna **100**) to the calibration PCB **330** (typically located at an end of the antenna **100**).

[00192] As shown in **FIG. 25**, a calibration PCB **330** extending perpendicular to the rearwardly extending phase shifter assemblies **300**, **300'** will allow for 32 shorter cables **370**

to be routed from the perpendicularly mounted phase shifters **150** (relative to the reflector **305** and/or support member **304**) of the rearwardly extending phase shifter assemblies **300**, **300'** to the calibration PCB **330**. The plurality of phase shifter assemblies **300**, **300'** may be serially connected to the calibration PCB **330**. The calibration PCB **330** may be mounted on the reflector **305** or support member **304** with the rearwardly extending phase shifter assemblies **300**, **300'**. In some embodiments, each phase shifter **150** may be coupled to the calibration PCB **330** through a respective blind mated or cabled connection **370**. Single cables **331** may then be routed from the calibration PCB **330** to the calibration ports **332a**, **332b**, thereby saving space within the base station antenna **100** and providing for a more accurate calibration of the antenna beams (*e.g.*, mitigating signal loss).

[00193] In some embodiments, the PING PCB **310** and the calibration PCB **330** may be combined into a single printed circuit board. In some embodiments, a base station antenna **100** may have a combined printed circuit board extending perpendicular to the phase shifter assemblies **300**, **300'** to utilize shorter cables as discussed above.

[00194] As shown above, the rearwardly extending phase shifter assemblies **300**, **300'** of the present invention may be advantageous over traditional configurations where the phase shifter assemblies **160a**, **160b** are oriented parallel to the reflector **305** within the base station antenna **100**. Some advantages may include, but are not limited to, providing for a modular design for manufacturing and assembling base station antennas **100**, allowing for less complex mechanical linkage designs within the antenna **100**, eliminating the need to stack the phase shifter assemblies **160a**, **160b** within the antenna **100**, allowing for more phase shifter assemblies to fit within a similarly sized antenna **100**, reducing the number of parts (*i.e.*, reducing manufacturing costs), saving space within the antenna **100**, and providing for more accurate calibration of antenna beams (*e.g.*, mitigating signal loss).

[00195] Another example of a phase shifter assembly **400** according to embodiments of the present invention is illustrated in **FIGS. 26-29D**. Features of the phase shifter assembly **400**, for example, individual components of the phase shifters such as inputs and outputs, transmission line traces, printed circuit boards, etc., may be as described above and duplicate discussion thereof may be omitted for the purposes of discussing **FIGS. 26-29D**.

[00196] Referring to **FIGS. 26A-27**, a phase shifter assembly **400** of the present invention may comprise a mounting base **401** formed of a polymeric material having opposing first and second primary sides **401A**, **401B**. In some embodiments, the polymeric mounting base **401** may comprise nylon, acetal, ABS, polycarbonate or polypropylene. In some embodiments, the mounting base **401** may be formed by injection molding. Forming the mounting base **401**

from a non-metallic material helps to eliminate some of the metal-to-metal interfaces within a base station antenna **100** which may reduce internal sources of passive intermodulation (PIM). In addition, changing the mounting base **401** of the phase shifter assembly **400** from a metallic material (*e.g.*, typically aluminum in existing designs) to a plastic injected molded part will reduce the weight of the component as well as reduce manufacturing costs.

[00197] As shown in **FIGS. 26A-26C**, the phase shifter assembly **400** further comprises a first main printed circuit board (PCB) **410A** residing on the first primary side **401A**. Similar to printed circuit boards discussed above, the first main PCB **410A** may comprise a plurality of radio frequency (RF) transmission paths **414** and a first wiper **420A** rotatably coupled to the first main PCB **410A**. The first wiper **420A** may comprise a first attachment link **423A**.

[00198] The phase shifter assembly **400** further comprises a second main PCB **410B** residing on the second primary side **401B**. The second main PCB **410B** may comprise a plurality of RF transmission paths **414** and a second wiper **420B** rotatably coupled to the second main PCB **410B**. The second wiper **420B** may comprise a second attachment link **423B**.

[00199] As shown in **FIG. 26A**, the second main PCB **410B** is aligned with the first main PCB **410A**. In some embodiments, the first attachment link **423A** of the first wiper **420A** and the second attachment link **423B** of the second wiper **420B** are each configured to couple their respective wiper **420A**, **420B** to a drive link **424**. The drive link **424** is coupled to a drive shaft **428** of a mechanical linkage (not shown). In some embodiments, the first and second wipers **420A**, **420B** are configured to rotate in concert relative to the first and second main PCB **410A**, **410B** to thereby adjust lengths of RF transmission paths on respective first and second main PCBs **410A**, **410B**.

[00200] As shown in **FIGS. 26A** and **26B**, the polymeric mounting base **401** may comprise a plurality of mounting apertures **402**. The mounting apertures **402** allow the mounting base **401** to be mounted to the reflector **305** of the antenna **100**, for example, with nylon screws or rivets. Alternative mounting features may also be incorporated into the phase shifter assembly **400**. For example, in some embodiments, snap fitting features or non-metallic standoffs may be integrated into the mounting base **401**.

[00201] As shown in **FIGS. 26A** and **26B**, the mounting apertures **402** are configured to allow horizontal mounting of the phase shifter assembly **400** within the antenna **100** (*i.e.*, parallel to the plane defined by the reflector **305**). Note that the phase shifter assembly **400** of the present invention may be configured to be vertically mounted to the reflector **305** (*i.e.*, perpendicular) within a base station antenna **100** utilizing a modified mounting base **401**, for

example, a mounting base **401** further comprising mounting flanges **302** (*see, e.g., FIGS. 19A and 19B*).

[00202] As shown in **FIGS. 26B and 26C**, the phase shifter assembly **400** has a length (**L'**), a width (**W'**) and a depth (**D'**). In addition to being adapted for mitigating PIM within a base station antenna **100**, the phase shifter assembly **400** according to embodiments of the present invention, provides a more compact size compared to existing phase shifter assemblies. For example, in some embodiments, the phase shifter assembly **400** may have a length (**L'**) in the range of about 180 mm to about 190 mm. In some embodiments, the phase shifter assembly **400** may have a width (**W'**) in the range of about 80 mm to about 90 mm. In some embodiments, the phase shifter assembly **400** may have a depth (**D'**) in the range of about 25 mm to about 35 mm.

[00203] In some embodiments, the phase shifter assembly **400** consumes about half of the space within a base station antenna **100** compared to existing phase shifter assembly designs. Thus, the phase shifter assembly **400** of the present invention may be used in narrow reflector antennas or in larger port antennas where space on the reflector **305** is a constraint.

[00204] Referring now to **FIG. 27**, in some embodiments, the phase shifter assembly **400** further comprises a grounding pin **461** (*see also, FIG. 26A*). **FIG. 27** is an enlarged bottom perspective view of the phase shifter assembly **400** with the bottom phase shifter printed circuit board (*i.e.*, the second main PCB **410B**) omitted to show the grounding pin **461**. As shown in **FIG. 27**, the grounding pin **461** extends through the mounting base **401** and is coupled (*e.g.*, soldered) to the first and second main PCBs **410A, 410B**. A grounding cable **460** connects the grounding pin **461** to the reflector **305** or other grounding point, thereby providing a ground for the phase shifter assembly **400**.

[00205] Referring now to **FIGS. 28-29C**, another phase shifter assembly **400'** according to embodiments of the present invention is illustrated. As shown in **FIG. 28**, the phase shifter assembly **400'** comprises at least two phase shifter assemblies **400** (*i.e.*, **400a, 400b**) described above mounted horizontally on the reflector **305**. The phase shifter assembly **400'** can be operated using a single drive shaft **428** (*e.g.*, square rod) without the need for additional mechanical linkages. In some embodiments, a base station antenna **100** may comprise a plurality of phase shifter assemblies **400'**, for example, in beam-forming antennas.

[00206] Referring now to **FIGS 29A-29C**, in some embodiments, a base station antenna **100** of the present invention may comprise at least two phase shifter assemblies **400a, 400b**. In some embodiments, the wipers **420A, 420B** of the four phase shifters (*i.e.*, two phase shifter assemblies **400a, 400b**) may be configured to rotate in concert

relative to the first and second main PCBs **410A**, **410B** of their respective phase shifter assembly **400a**, **400b** to adjust the phase (or tilt) of the antenna **100**. The first and second attachment links **423A**, **423B** of the first and second wipers **420A**, **420B** of one of the phase shifter assemblies **400a** and the first and second attachment links **423A**, **423B** of the first and second wipers **420A**, **420B** of the second phase shifter assemblies **400b** may be configured to couple their respective wipers **420A**, **420B** to the drive link **424** which is coupled to the drive shaft **428** of a mechanical linkage. The first and second wipers **420A**, **420B** of each of the at least two phase shifter assemblies **400a**, **400b** may be configured to rotate in concert relative to their respective first and second main printed circuit boards **410A**, **410B** to thereby adjust the phase of the base station antenna **100**.

[00207] FIG. 29A illustrates the phase shifter assembly **400'** applying minimum tilt, FIG. 29B illustrates the phase shifter assembly **400'** applying middle tilt, and FIG. 29C illustrates the phase shifter assembly **400'** applying maximum tilt.

[00208] Referring now to FIGS. 30A-32C, another mounting base **401'** according to embodiments of the present invention is illustrated. The mounting base **401'** comprises an alternative option for mounting the phase shifter assembly **400'** to the reflector **305'** of a base station antenna **100**.

[00209] As shown in FIGS. 30A and 30B, the mounting base **401'** of the phase shifter assembly **400'** may comprise mounting features **403**, **404** which may allow the phase shifter assembly **400'** to be easily mounted to the reflector **305'** of an antenna **100**. In some embodiments, the mounting features **403**, **404** may be integral with the mounting base **401'**. As shown in FIGS. 30A and 30B, the mounting features **403** may extend outwardly from and perpendicular to the second primary side **401B'** of the mounting base **401'**. The mounting features **403** may comprise a snap-lock or snap-fit feature that is configured to be received by mounting cutouts (or apertures) **306b'** residing in a base **305b** of the reflector **305'** (*see, e.g., FIG. 31 and FIGS. 32A-32C*). The mounting apertures **306b'** are sized to receive a respective mounting feature **403**. For example, the mounting features **403** may comprise a cantilever snap joint having a flexible U-shaped end **403e** configured to interlock with a respective mounting aperture **306b'**.

[00210] Still referring to FIGS. 30A and 30B, the mounting features **404** may extend outwardly from a secondary side **401C** of the mounting base **401'**. The mounting features **404** may comprise a snap-lock or snap-fit feature that is configured to be received by mounting cutouts (or apertures) **306a'** residing in a sidewall **305w** of the reflector **305'** (*see, e.g., FIG. 31 and FIGS. 32A-32C*). The mounting apertures **306a'** are sized to receive a

respective mounting feature 404. For example, the mounting features 404 may be inserted into a wide portion of a respective aperture 306a' and then slid to a narrow portion of the aperture 306a', thereby locking the mounting feature 404 within the mounting aperture 306a' (see, e.g., FIG. 31 and FIG. 32B).

[00211] As shown in FIGS. 32A-32C, in some embodiments, the mounting features 403 are each received (and secured) in respective mounting apertures 306b' residing in the base 305b of the reflector 305' and the mounting features 404 are each received (and secured) in respective mounting apertures 306a' residing in the sidewall 305w of the reflector 305'.

[00212] FIG. 33 illustrates the entire phase shifter assembly 400' mounted on reflector 305' using the mounting features 403, 404 described above. As shown in FIG. 33, the phase shifter assembly 400' may be mounted against the sidewall 305w of the reflector 305'.

[00213] Referring now to FIGS. 34A-36C, another mounting base 401'' according to embodiments of the present invention is illustrated. The mounting base 401'' comprises another alternative option for mounting the phase shifter assembly 400' to the reflector 305'' of a base station antenna 100.

[00214] As shown in FIGS. 34A and 34B, the mounting base 401'' of the phase shifter assembly 400' may also comprise mounting features 403', 404' which may allow the phase shifter assembly 400' to be easily mounted to the reflector 305'' of an antenna 100. In some embodiments, the mounting features 403', 404' may be integral with the mounting base 401''. Similar to the mounting features 403, 404, mounting features 403', 404' may comprise snap-lock or snap-fit features that are configured to be received by mounting cutouts (or apertures) 306a', 306b' in the reflector 305''.

[00215] Still referring to FIGS. 34A and 34B, the mounting features 403' extend outwardly from and perpendicular to the second primary side 401B'' of the mounting base 401'' and may comprise a similar cantilever snap joint having a flexible U-shaped end 403e configured to interlock with the mounting aperture 306b', as described above with respect to mounting base 401'. Mounting base 401'' differs from mounting base 401' in that the mounting features 403' also extend outwardly from and perpendicular to the second primary side 401B'' of the mounting base 401''. Like mounting features 404, the mounting features 404' may be inserted into a wide portion of a respective aperture 306a' and then slid to a narrow portion of the aperture 306a', thereby locking the mounting feature 404' within the mounting aperture 306a' (see, e.g., FIG. 35 and FIG. 36B).

[00216] The mounting apertures **306a'**, **306b'** are sized to receive a respective mounting feature **403'**, **404'**. As shown in **FIG. 35**, since all of the mounting features **403'**, **404'** extend outwardly from the second primary side **401B''** of the mounting base **401''**, all of the mounting apertures **306a'**, **306b'** reside in the base **305b'** of the reflector **305''**. In some embodiments, the mounting apertures **306a'** may be offset from the mounting apertures **306b'** in the base **305b'** of the reflector **305''**. As such, the mounting features **403**, **404** are positioned on the second primary side **401B''** of the mounting base **401''** such that the features **403**, **404** will align with the mounting apertures **306a'**, **306b'** when the mounting base **401'** is being mounted to the reflector **305''**.

[00217] As shown in **FIGS. 36A-36C**, in some embodiments, the mounting features **403'** are each received (and secured) in a respective mounting aperture **306b'** and the mounting features **404'** are each received (and secured) in a respective mounting aperture **306a'**.

[00218] **FIG. 37** illustrates the entire phase shifter assembly **400'** mounted on reflector **305''** using the mounting features **403'**, **404'** described above.

[00219] As noted above, a RET actuator is used to drive the moveable element of a phase shifter **150**/phase shifter assembly **200**, **200'**, **300**, **300'**. *See, e.g.*, U.S. Provisional Application Serial No. 62/696,996, the contents of which are hereby incorporated by reference as if recited in full herein for example components an RET actuator that may be used in the base station antennas according to embodiments of the present invention. The RET actuator can be a multi-RET actuator that includes multiple output members that can drive multiple respective mechanical linkages.

[00220] It will be appreciated that the above embodiments are intended as examples only, and that a wide variety of different embodiments fall within the scope of the present invention. It will also be appreciated that any of the above embodiments or features of different embodiments may be combined.

[00221] The present invention has been described above with reference to the accompanying drawings. The invention is not limited to the illustrated embodiments; rather, these embodiments are intended to fully and completely disclose the invention to those skilled in this art. In the drawings, like numbers refer to like elements throughout. Thicknesses and dimensions of some components may be exaggerated for clarity.

[00222] Spatially relative terms, such as "under", "below", "lower", "over", "upper", "top", "bottom" and the like, may be used herein for ease of description to describe one element or feature's relationship to another element(s) or feature(s) as illustrated in the figures. It will be understood that the spatially relative terms are intended to encompass different orientations of

the device in use or operation in addition to the orientation depicted in the figures. For example, if the device in the figures is turned over, elements described as "under" or "beneath" other elements or features would then be oriented "over" the other elements or features. Thus, the exemplary term "under" can encompass both an orientation of over and under. The device may be otherwise oriented (rotated 90 degrees or at other orientations) and the spatially relative descriptors used herein interpreted accordingly.

[00223] Herein, the terms "attached", "connected", "interconnected", "contacting", "mounted" and the like can mean either direct or indirect attachment or contact between elements, unless stated otherwise.

[00224] Well-known functions or constructions may not be described in detail for brevity and/or clarity. As used herein the expression "and/or" includes any and all combinations of one or more of the associated listed items.

[00225] The terminology used herein is for the purpose of describing particular embodiments only and is not intended to be limiting of the invention. As used herein, the singular forms "a", "an" and "the" are intended to include the plural forms as well, unless the context clearly indicates otherwise. It will be further understood that the terms "comprises", "comprising", "includes" and/or "including" when used in this specification, specify the presence of stated features, operations, elements, and/or components, but do not preclude the presence or addition of one or more other features, operations, elements, components, and/or groups thereof.

That which is claimed is:

1. A phase shifter assembly, comprising:
a main printed circuit board comprising opposing first and second primary sides, wherein the main printed circuit board comprises a plurality of radio frequency (RF) transmission paths on the first primary side and a plurality of RF transmission paths on the second primary side;
a first wiper arm rotatably coupled to the main printed circuit board and electrically coupled to at least some of the plurality of transmission paths on the first primary side of the main printed circuit board; and
a second wiper arm rotatably coupled to the main printed circuit board and electrically coupled to at least some of the plurality of transmission paths on the second primary side of the main printed circuit board.
2. The phase shifter assembly of Claim 1, further comprising a plurality of coaxial cables coupled to each of the first and second primary sides of the main printed circuit board.
3. The phase shifter assembly of any one of Claims 1 or 2, wherein the main printed circuit board comprises a ground plane sandwiched between opposing dielectric layers.
4. The phase shifter assembly of any one of Claims 1-3, further comprising a plurality of input and/or output pads coupled to the plurality of RF transmission paths on each of the first and second primary sides of the main printed circuit board.
5. The phase shifter assembly of Claim 4, wherein the input and/or output pads on the first primary side are laterally and/or longitudinally offset from the input and/or output pads on the second primary side.
6. The phase shifter assembly of any one of the preceding claims, further comprising a pivot pin extending through an aperture in the main printed circuit board defining a pivot point, wherein the pivot pin is coupled to both the first and second wiper arms.

7. The phase shifter assembly of Claim 6, wherein the main printed circuit board comprises an arcuate slot residing adjacent an arcuate segment of at least one of the plurality of RF transmission paths, and wherein the first and second wiper arms cooperate with the slot and the pivot pin to rotate back and forth over the RF transmission paths.

8. The phase shifter assembly of any one of the preceding claims, wherein the main printed circuit board comprises an arcuate top side residing adjacent an arcuate segment of at least one of the plurality of RF transmission paths.

9. The phase shifter assembly of Claim 2, further comprising at least one connector block assembly attached to the main printed circuit board, wherein the at least one connector block assembly is configured to hold a plurality of coaxial cables in first and second stacked rows, the first row holding the coaxial cables coupled to the first primary side of the main printed circuit board and the second row holding the coaxial cables coupled to the second primary side of the main printed circuit board.

10. The phase shifter assembly of any one of Claims 2-9, further comprising at least one transition block connector that resides completely outside a boundary of the main printed circuit board and couples a first pair of larger coaxial cables to a corresponding first pair of smaller outer diameter coaxial cables, wherein one coaxial cable of the pair of the smaller outer diameter coaxial cables couples to the first primary side of the main printed circuit board while another coaxial cable of the pair of the smaller outer diameter coaxial cables couples to the second primary side of the main printed circuit board.

11. The phase shifter assembly of any one of Claims 2-10, wherein at least some of the coaxial cables have end portions that comprises a first terminal end segment that merges into a second terminal end segment, wherein the first terminal end segment has an axially extending center line, and wherein the second terminal end segment is bent to reside closer to the main printed circuit board than the first terminal end segment, optionally at an angle between 45 and 90 degrees from the axially extending center line of the first terminal end segment.

12. The phase shifter assembly of any one of the preceding claims, wherein the main printed circuit board has a thickness in a range of about 2 mm to about 10 mm, optionally a range of about 3 mm to about 5 mm.

13. The phase shifter assembly of any one of the preceding claims, wherein the main printed circuit board has a perimeter, wherein the perimeter comprises a pair of long sides and a pair of short sides, with one long side defining a bottom and one long side defining a top, and wherein the main printed circuit board comprises input and/or output pads on the first primary side that are offset in an X direction from input and/or output pads on the second primary side, with the X direction defined as extending in a direction between the top and bottom.

14. The phase shifter assembly of any one of the preceding claims, wherein the main printed circuit board has a perimeter, wherein the perimeter comprises a pair of long sides and a pair of short sides, with one long side defining a bottom and one long side defining a top, and wherein input and/or output pads on the first and second primary surfaces include a plurality of pads that reside adjacent the top and a plurality of pads that reside adjacent the bottom of the main printed circuit board.

15. The phase shifter assembly of Claim 14, wherein the input pad on the first primary side resides in a bottom corner or a top corner of the main printed circuit board and wherein the input pad on the second primary side resides in the other of the bottom corner or the top corner across a Y direction of the main printed circuit board, and optionally wherein the main printed circuit board comprises an arcuate slot that resides adjacent an arcuate segment of one of the transmission lines.

16. The phase shifter assembly of any one of Claims 7-15, wherein the main printed circuit board has a top and an opposing bottom with the top positioned closer to an outer edge of the first and second wiper arms than the bottom, wherein the main printed circuit board comprises input and/or output pads on the first primary side above the slot further away from the pivot pin closer to the first wiper arm, and wherein the main printed circuit board comprises input and/or output pads on the second primary side that are below the slot.

17. The phase shifter assembly of any one of Claims 6-16, wherein the pivot pin resides at a medial location of the main printed circuit board, optionally centered in a Y direction where the Y direction corresponds to a lateral direction associated with a primary direction of the transmission paths.

18. The phase shifter assembly of any one of Claims 6-16, wherein the pivot pin resides closer to a bottom side of the main printed circuit board than the top side of the main printed circuit board, optionally centered in a Y direction where the Y direction corresponds to a lateral direction associated with a primary direction of the transmission paths.

19. The phase shifter assembly of any one of the preceding claims, wherein the first and second wiper arms are coupled to each other at a respective outer edge portion thereof.

20. A base station antenna with a housing enclosing the phase shifter assembly of any one of the preceding claims, optionally wherein either:

(a) the phase shifter assembly is held in a vertical orientation in the housing with the main printed circuit board vertically oriented; or (b) the phase shifter assembly is held in a horizontal orientation in the housing with the main printed circuit board horizontally oriented.

21. A base station antenna, comprising:
a plate comprising opposing first and second primary surfaces and a first slot;
a first main printed circuit board comprising a plurality of radio frequency (RF) transmission paths residing on the first primary surface of the plate;
a second main printed circuit board comprising a plurality of RF transmission paths residing on the second primary surface of the plate, aligned with the first main printed circuit board;
a first wiper arm rotatably coupled to the first main printed circuit board; and
a second wiper arm rotatably coupled to the second main printed circuit board,
wherein the first and second wiper arms cooperate with the first slot in the plate and a pivot pin extending through the first and second main printed circuit boards and the plate to be able to rotate in concert relative to the first and second main printed circuit boards to thereby adjust lengths of RF transmission paths on respective first and second main printed circuit boards.

22. The base station antenna of Claim 21, wherein the metal panel further comprises a second slot adjacent the first slot, the base station antenna further comprising:

- a third main printed circuit board residing adjacent the first main printed circuit board and on the first primary surface of the plate;
- a fourth main printed circuit board residing adjacent the second main printed circuit board and on the second primary surface of the plate;
- a third wiper arm rotatably coupled to the third main printed circuit board; and
- a fourth wiper arm rotatably coupled to the fourth main printed circuit board,

wherein the third and fourth wiper arms cooperate with the second slot in the plate and a pivot pin extending through the third and fourth main printed circuit boards and the plate to be able to rotate in concert relative to the third and fourth main printed circuit boards to thereby adjust lengths of RF transmission paths on respective third and fourth main printed circuit boards.

23. The base station antenna of any one of Claims 21 or 22, further comprising a plurality of cable channels held by or defined by the plate that route a plurality of coaxial cables to the first and second main printed circuit boards.

24. The base station antenna of any one of Claims 22 or 23, wherein the first and second slots are first and second arcuate slots that reside at a medial location of the metal panel, and wherein the first arcuate slot has a first radius of curvature and the second arcuate slot has a second radius of curvature, the first and second radius of curvatures being the same but oriented to provide opposing arc segments.

25. The base station antenna of any one of Claims 22-24, wherein the first, second, third and fourth main printed circuit boards have a perimeter, wherein the perimeter comprises a pair of long sides and a pair of short sides, wherein one long side of the pair of long sides defining a bottom and another long side of the pair of long sides defining a top, wherein the tops of the first and third printed circuit boards are arcuate and reside adjacent each other with the first and second slots therebetween, and wherein the tops of the second and fourth printed circuit boards are arcuate and reside adjacent each other with the first and second slots therebetween.

26. The base station antenna of any one of Claims 23-25, wherein the plurality of cable channels are defined at least partially by a connector block assembly or a transition block connector.

27. The base station antenna of any one of Claims 21-26, wherein the phase shifter assembly is held in a vertical orientation with the plate and the first and second printed circuit boards parallel to each other and vertically oriented.

28. The base station antenna of any one of Claims 21-26, wherein the phase shifter assembly is held in a horizontal orientation with the plate and the first and second printed circuit boards parallel to each other and horizontally oriented.

29. A base station antenna, comprising:
a reflector; and
a plurality of rearwardly extending phase shifter assemblies, wherein each of the phase shifter assemblies are aligned substantially perpendicular to a plane defined by the reflector.

30. The base station antenna of Claim 29, wherein each phase shifter assembly comprises:
a first and a second plate arranged back-to-back and extending parallel to each other, each plate comprising an outer surface;
a first main printed circuit board residing on the outer surface of the first plate, the first main printed circuit board comprising a plurality of radio frequency (RF) transmission paths;
a second main printed circuit board residing on the outer surface of the second plate, the second main printed circuit board comprising a plurality of RF transmission paths, wherein the second main printed circuit board is aligned with the first main printed circuit board;
a first wiper rotatably coupled to the first main printed circuit board, the first wiper having a first attachment link; and
a second wiper rotatably coupled to the second main printed circuit board, the second wiper having a second attachment link,

wherein the first attachment link of the first wiper and the second attachment link of the second wiper are each configured to couple their respective wiper to a drive shaft of a mechanical linkage,

wherein the first and second wipers are configured to rotate in concert relative to the first and second main printed circuit boards to thereby adjust lengths of RF transmission paths on respective first and second main printed circuit boards.

31. The base station antenna of any one of Claims 29 or 30, wherein each phase shifter assembly comprises one or more mounting flanges, each mounting flange being configured to mount the phase shifter assembly to the reflector or a support member.

32. The base station antenna of Claim 31, wherein the plurality of phase shifter assemblies are mounted to the reflector by the mounting flanges.

34. The base station antenna of Claim 31, wherein the plurality of phase shifter assemblies are mounted on the support member by the mounting flanges.

33. The base station antenna of any one of Claims 30-34, wherein the mechanical linkage of each phase shifter assembly align in the same transverse plane.

34. The base station antenna of any one of Claims 29-33, further comprising an AISG PING printed circuit board extending perpendicular to the plurality of phase shifter assemblies.

35. The base station antenna of Claim 34, wherein the plurality of phase shifter assemblies are coupled to the AISG PING printed circuit board through respective blind mated or cabled connections.

36. The base station antenna of any one of Claims 29-35, further comprising a calibration circuit board extending perpendicular to the plurality of phase shifter assemblies.

37. The base station antenna of Claim 36, wherein the plurality of phase shifter assemblies are coupled to the calibration circuit board through respective blind mated or cabled connections.

38. The base station antenna of any one of Claims 29-37, wherein the base station antenna comprises about 10 to about 30 rearwardly extending phase shifter assemblies.

39. A method of assembling a base station antenna, the method comprising:
providing a plurality of phase shifter assemblies, each phase shifter assembly comprising a first and a second plate arranged back-to-back and extending parallel to each other;

mounting each phase shifter assembly to a support member such that the first and second plates are oriented perpendicular to the support member; and

integrating the support member comprising the plurality of phase shifter assemblies mounted thereon into the base station antenna.

40. The method of Claim 39, the method further comprising integrating an AISG PING printed circuit board extending perpendicular to the plurality of phase shifter assemblies.

41. The method of any one of Claims 39 or 40, the method further comprising integrating a calibration printed circuit board extending perpendicular to the plurality of phase shifter assemblies.

42. A phase shifter assembly adapted for mitigating passive intermodulation within a base station antenna, the assembly comprising:

a polymeric mounting base having opposing first and second primary sides;

a first main printed circuit board residing on the first primary side, the first main printed circuit board comprising a plurality of radio frequency (RF) transmission paths;

a second main printed circuit board residing on the second primary side, the second main printed circuit board comprising a plurality of RF transmission paths, wherein the second main printed circuit board is aligned with the first main printed circuit board;

a first wiper rotatably coupled to the first main printed circuit board, the first wiper having a first attachment link; and

a second wiper rotatably coupled to the second main printed circuit board, the second wiper having a second attachment link,

wherein the first attachment link of the first wiper and the second attachment link of the second wiper are each configured to couple their respective wiper to a drive shaft of a mechanical linkage; and

wherein the first and second wipers are configured to rotate in concert relative to the first and second main printed circuit boards to thereby adjust lengths of RF transmission paths on respective first and second main printed circuit boards.

43. The phase shifter assembly of Claim 42, wherein the phase shifter assembly has a depth in the range of about 25 mm to about 35 mm, a length in the range of about 180 mm to about 190 mm, and a width in the range of about 80 mm to about 90 mm.

44. A base station antenna, comprising:

a reflector; and

a plurality of phase shifter assemblies, each phase shifter assembly comprising:

a polymeric mounting base comprising opposing first and second primary sides;

a first main printed circuit board residing on the first primary side, the first main printed circuit board comprising a plurality of radio frequency (RF) transmission paths;

a second main printed circuit board residing on the second primary side, the second main printed circuit board comprising a plurality of RF transmission paths, wherein the second main printed circuit board is aligned with the first main printed circuit board;

a first wiper rotatably coupled to the first main printed circuit board, the first wiper having a first attachment link; and

a second wiper rotatably coupled to the second main printed circuit board, the second wiper having a second attachment link;

wherein the first attachment link of the first wiper and the second attachment link of the second wiper are each configured to couple their respective wiper to a drive shaft of a mechanical linkage; and

wherein the first and second wipers are configured to rotate in concert relative to the first and second main printed circuit boards to thereby adjust lengths of RF transmission paths on respective first and second main printed circuit boards.

45. The base station antenna of Claim 44, wherein the base station antenna comprises at least two phase shifter assemblies, wherein first and second attachment links of one of the at least two phase shifter assemblies and the first and second attachment links of the second of the at least two phase shifter assemblies are configured to couple their respective wipers to a drive link that is coupled to the drive shaft of the mechanical linkage, and wherein the first and second wipers of each of the at least two phase shifter assemblies are configured to rotate in concert relative to their respective first and second main printed circuit boards to thereby adjust the phase of the base station antenna.

46. The base station antenna of any one of Claims 44 or 45, wherein the polymeric mounting base comprises mounting holes, and wherein each of the phase shifter assemblies is mounted to the reflector with nylon screws or rivets received through the mounting holes.

47. The base station antenna of any one of Claims 44-46, wherein the phase shifter assembly comprises mounting features integral with the polymeric mounting base and configured to be received by a plurality of mounting apertures in the reflector.

48. The base station antenna of Claim 47, wherein the mounting features comprise a snap-lock or snap-fit feature.

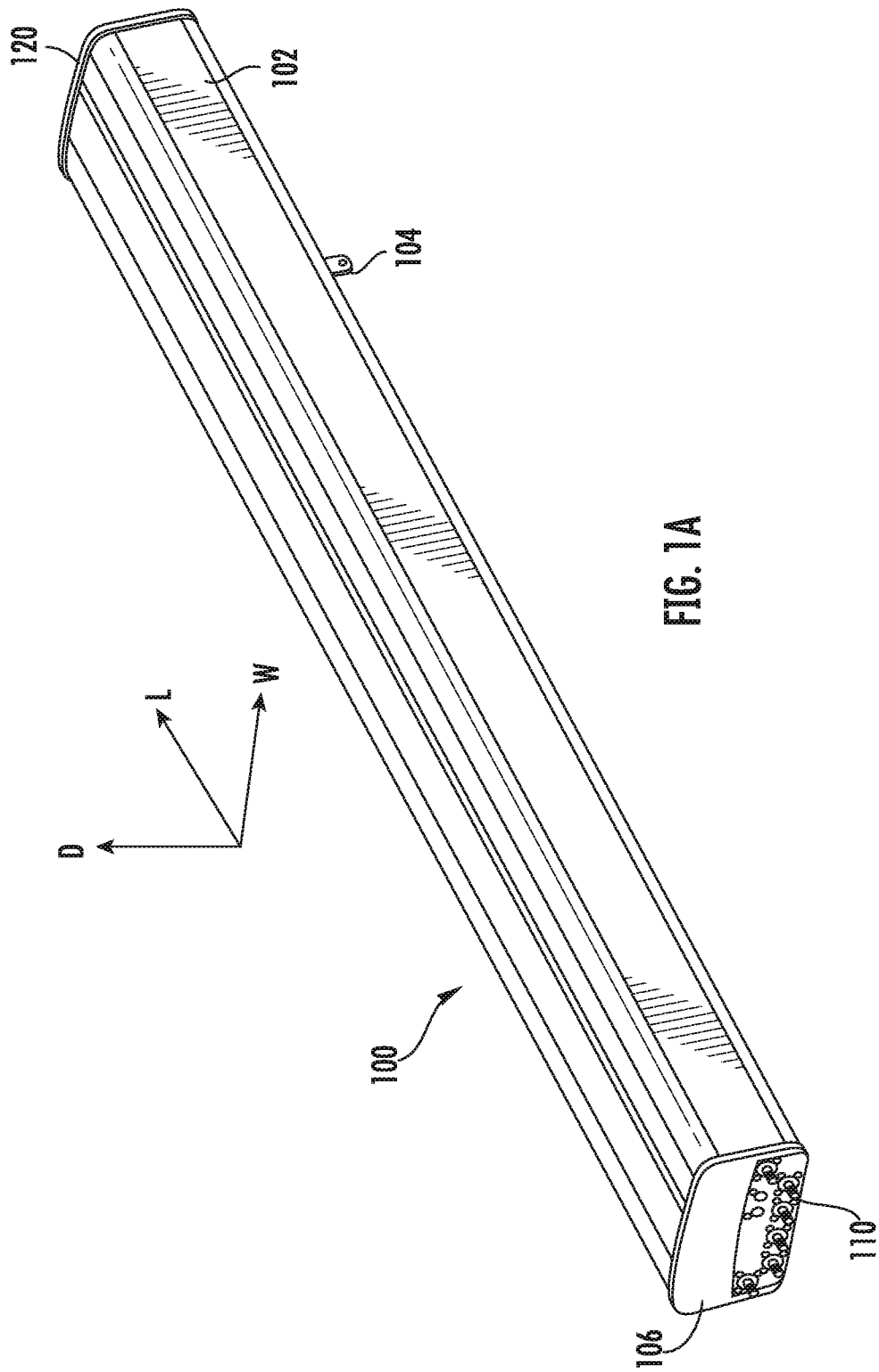

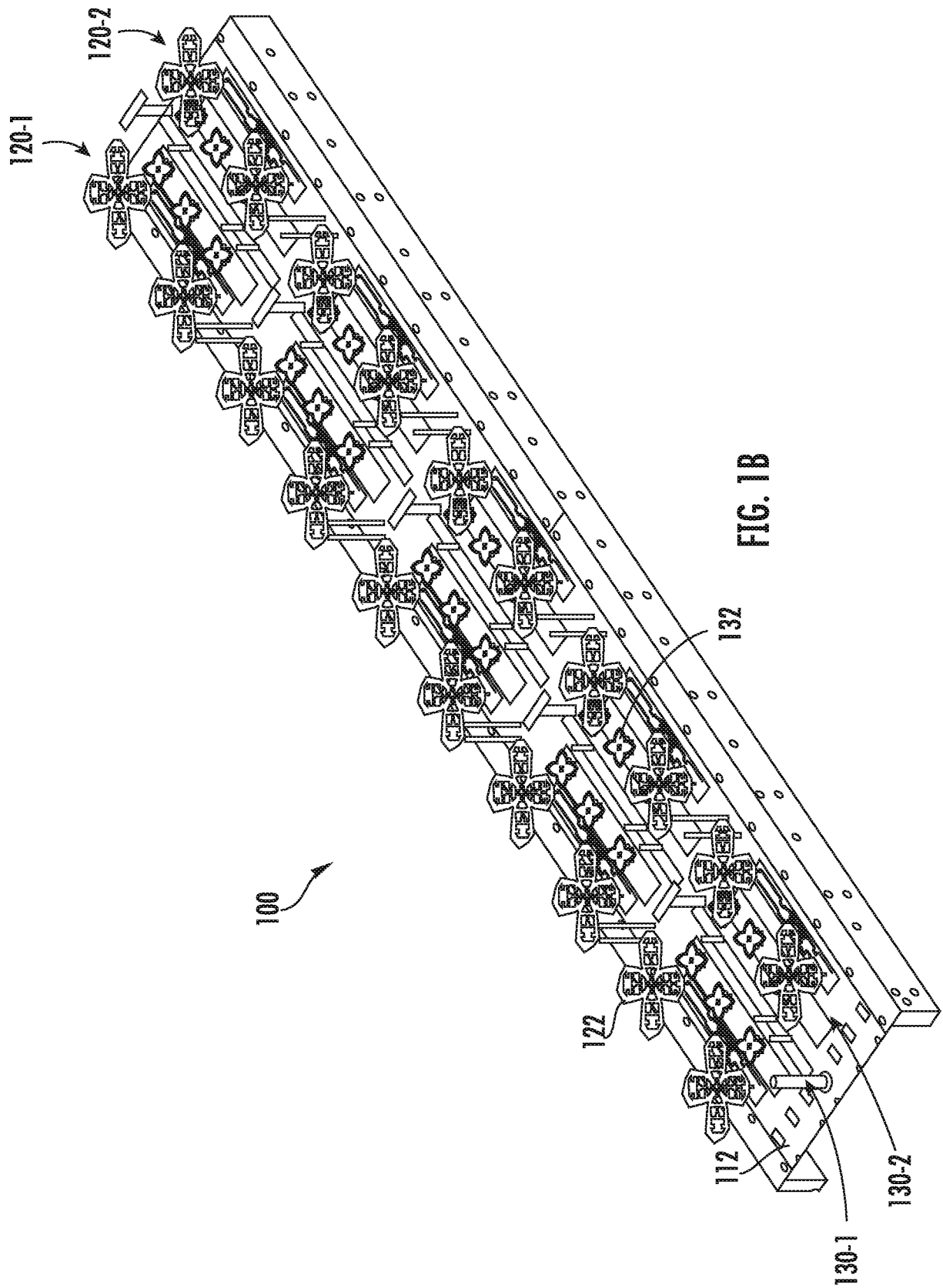

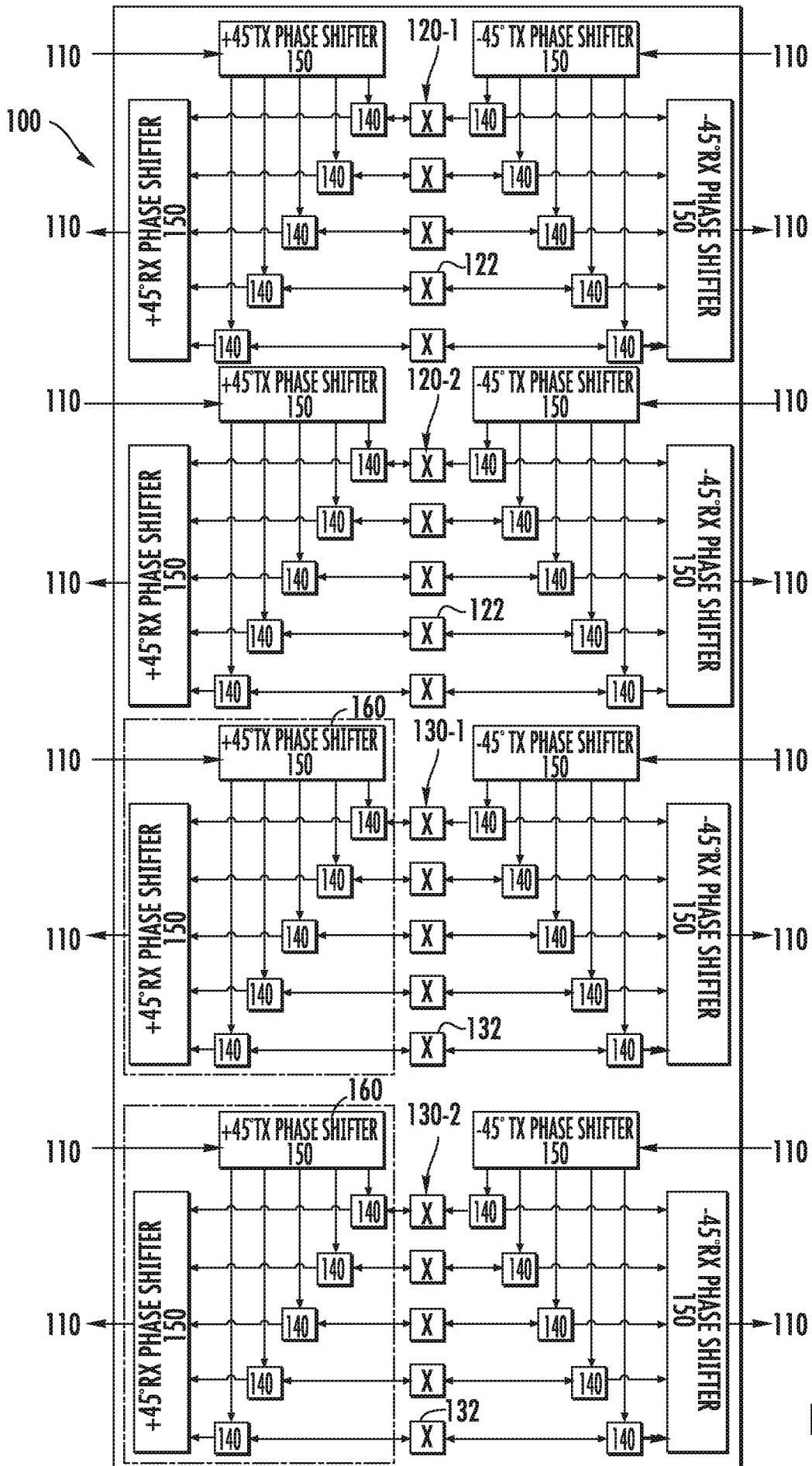

FIG. 2

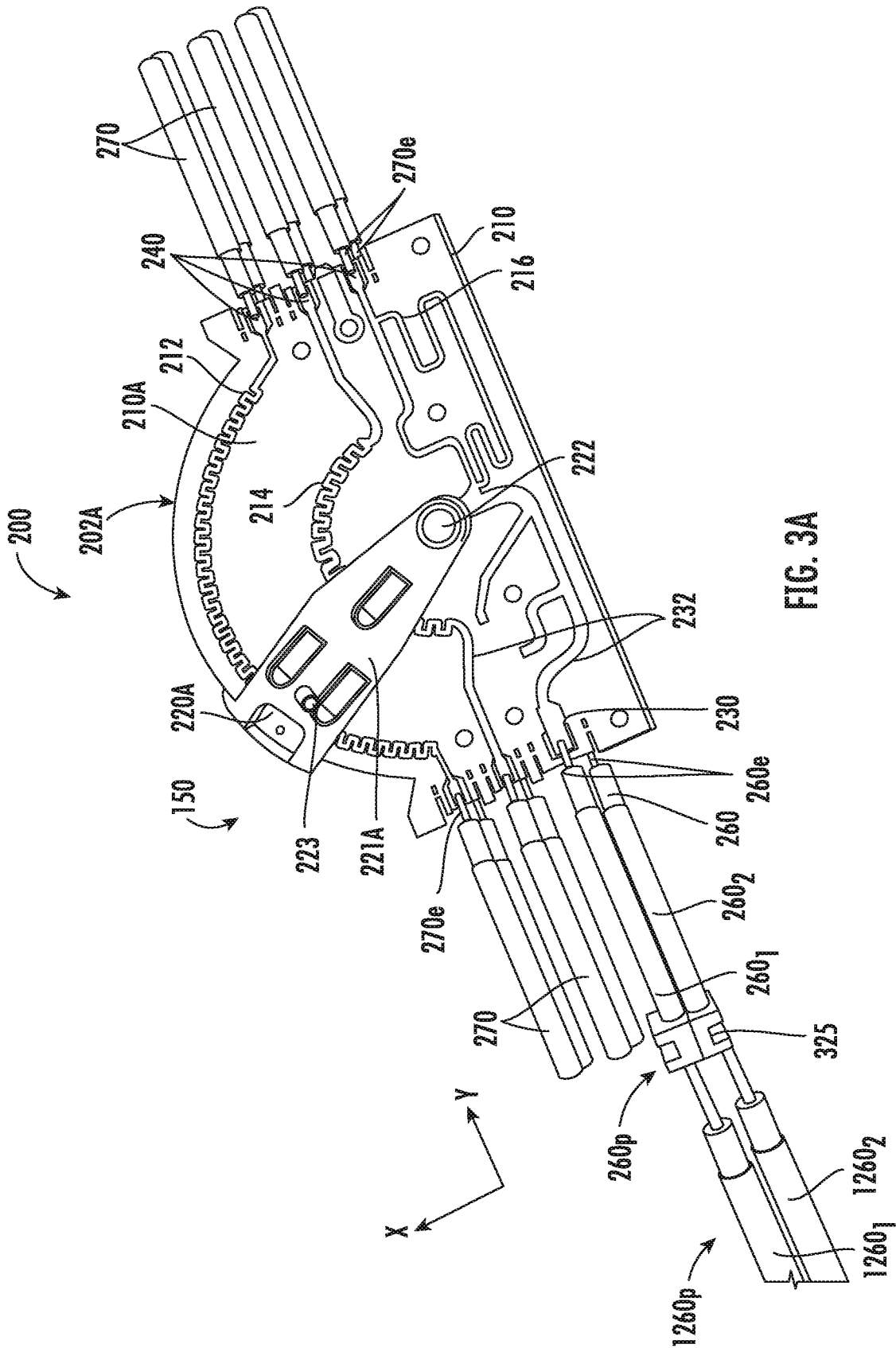
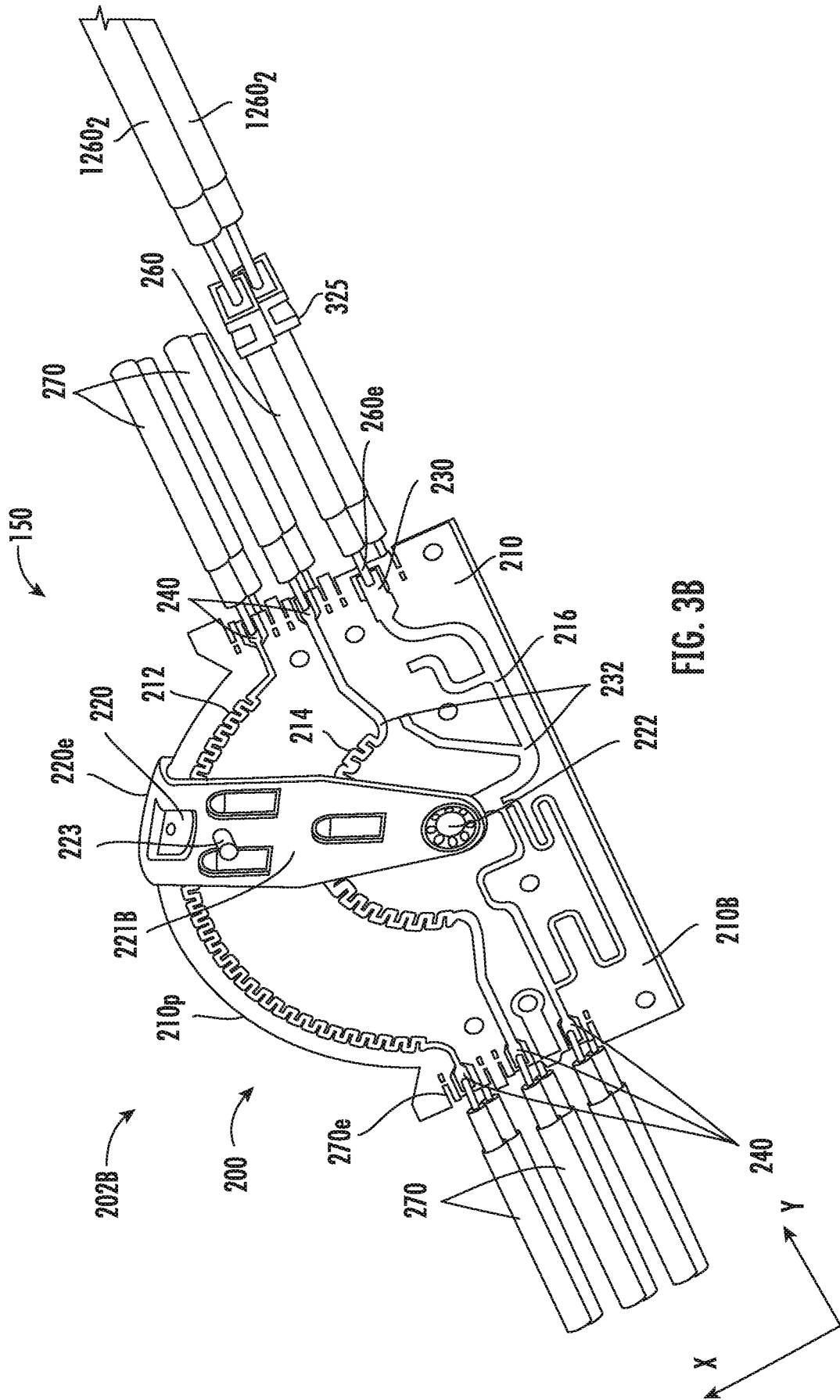

FIG. 3A



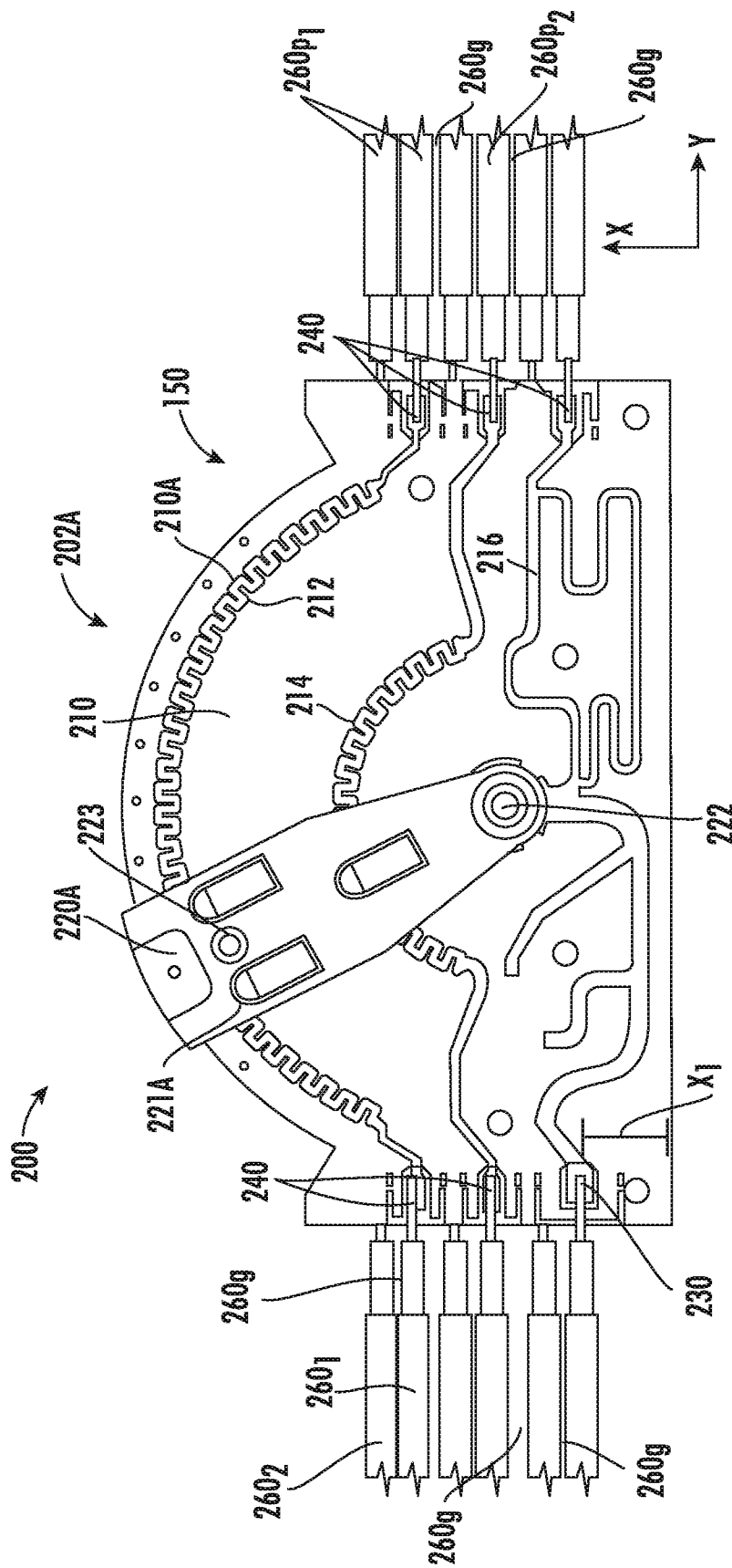

FIG. 4A

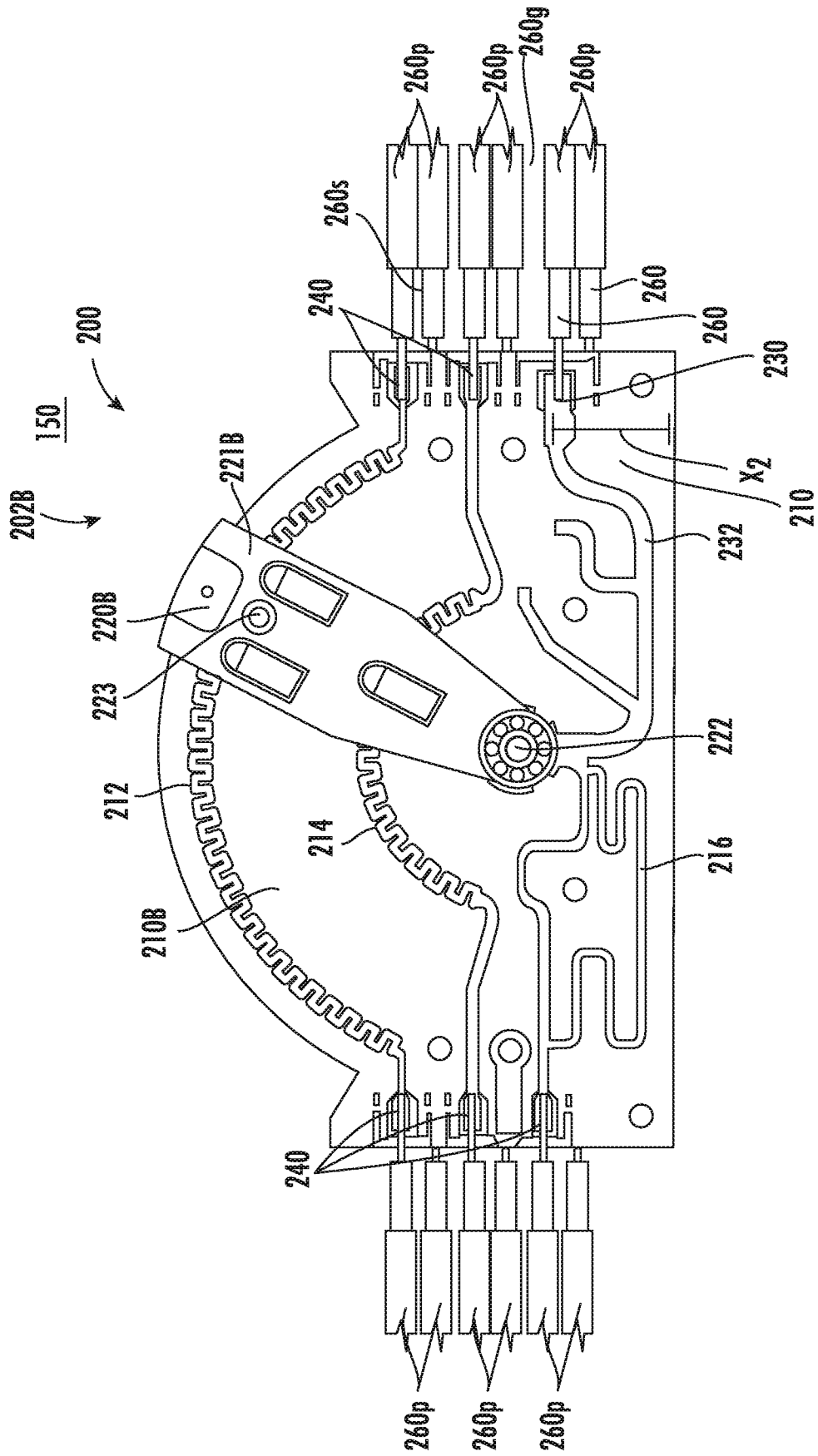

FIG. 4B

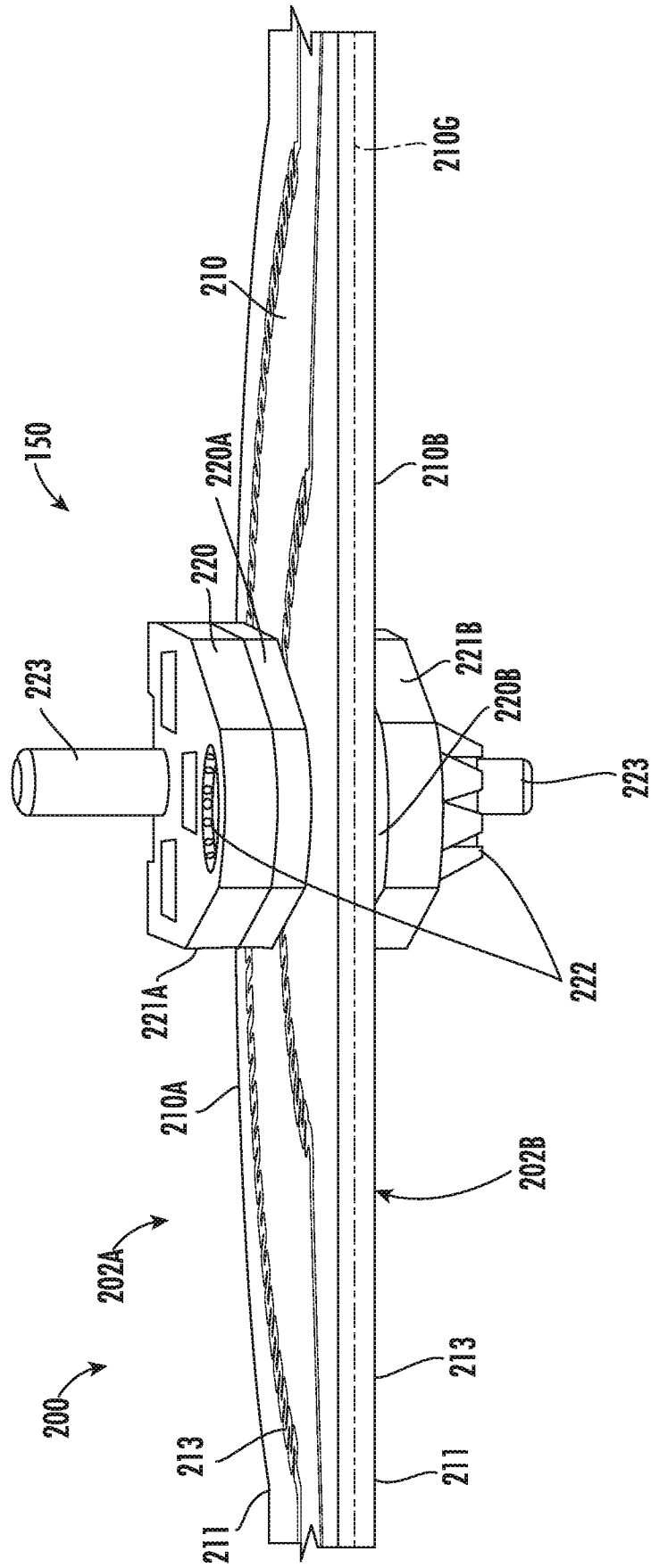

FIG. 5

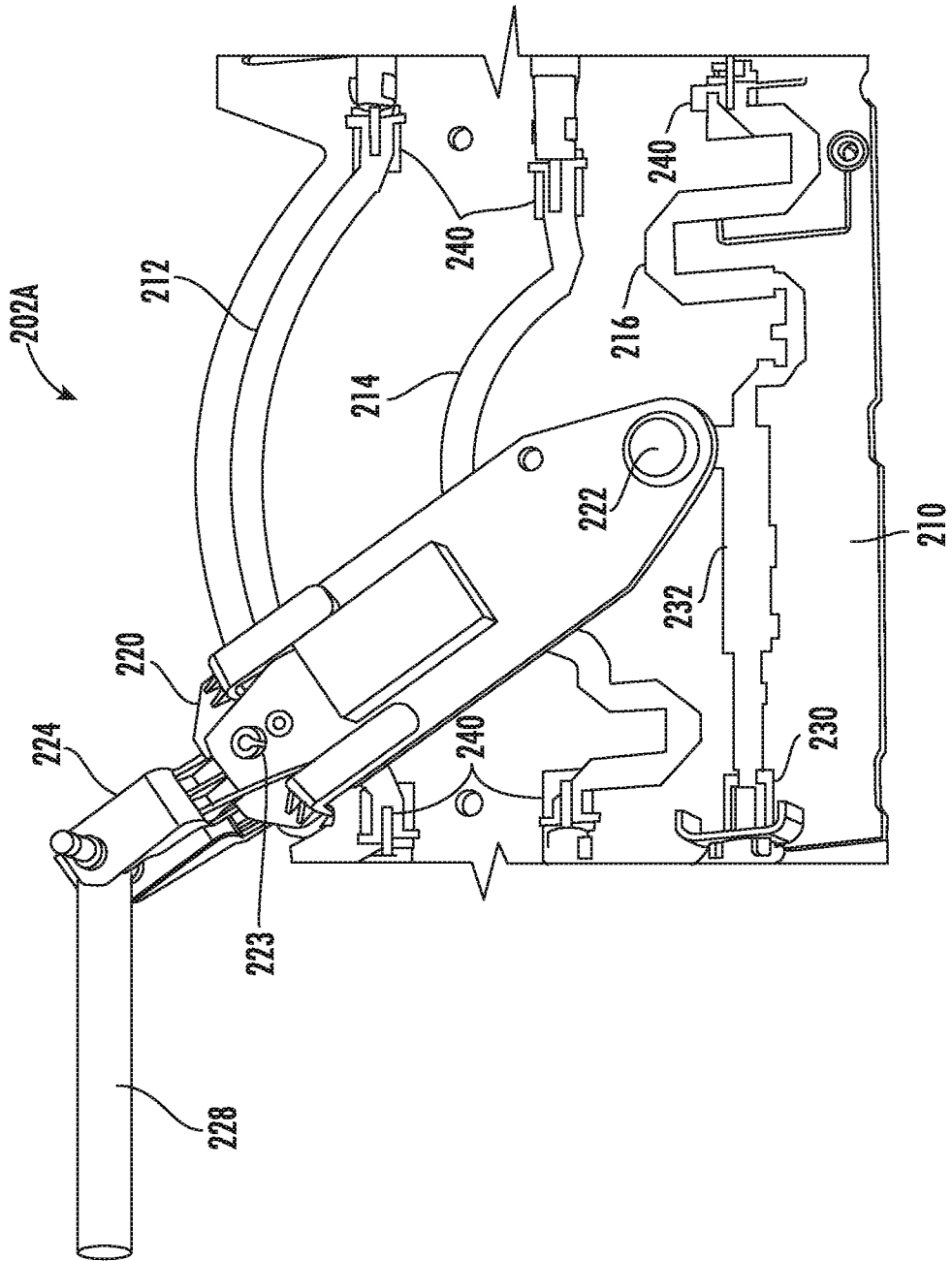

FIG. 6

10/48

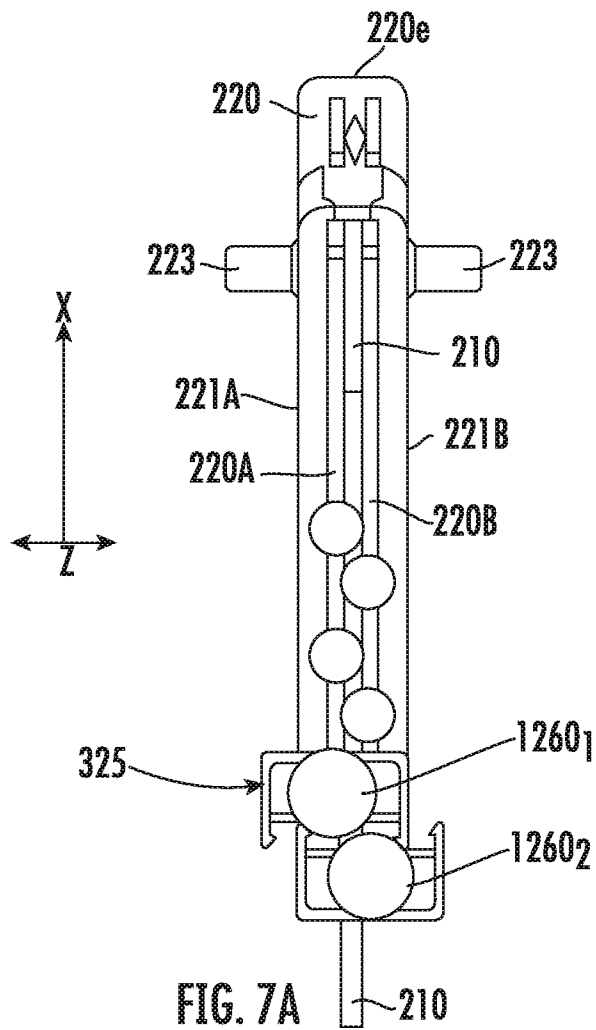

FIG. 7A

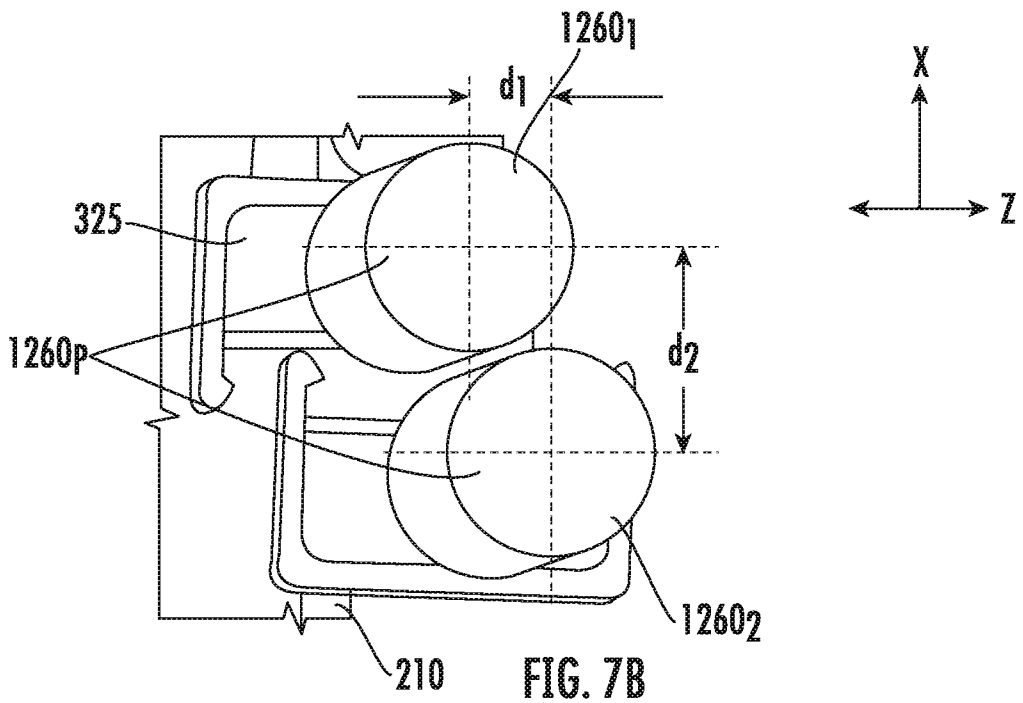

FIG. 7B

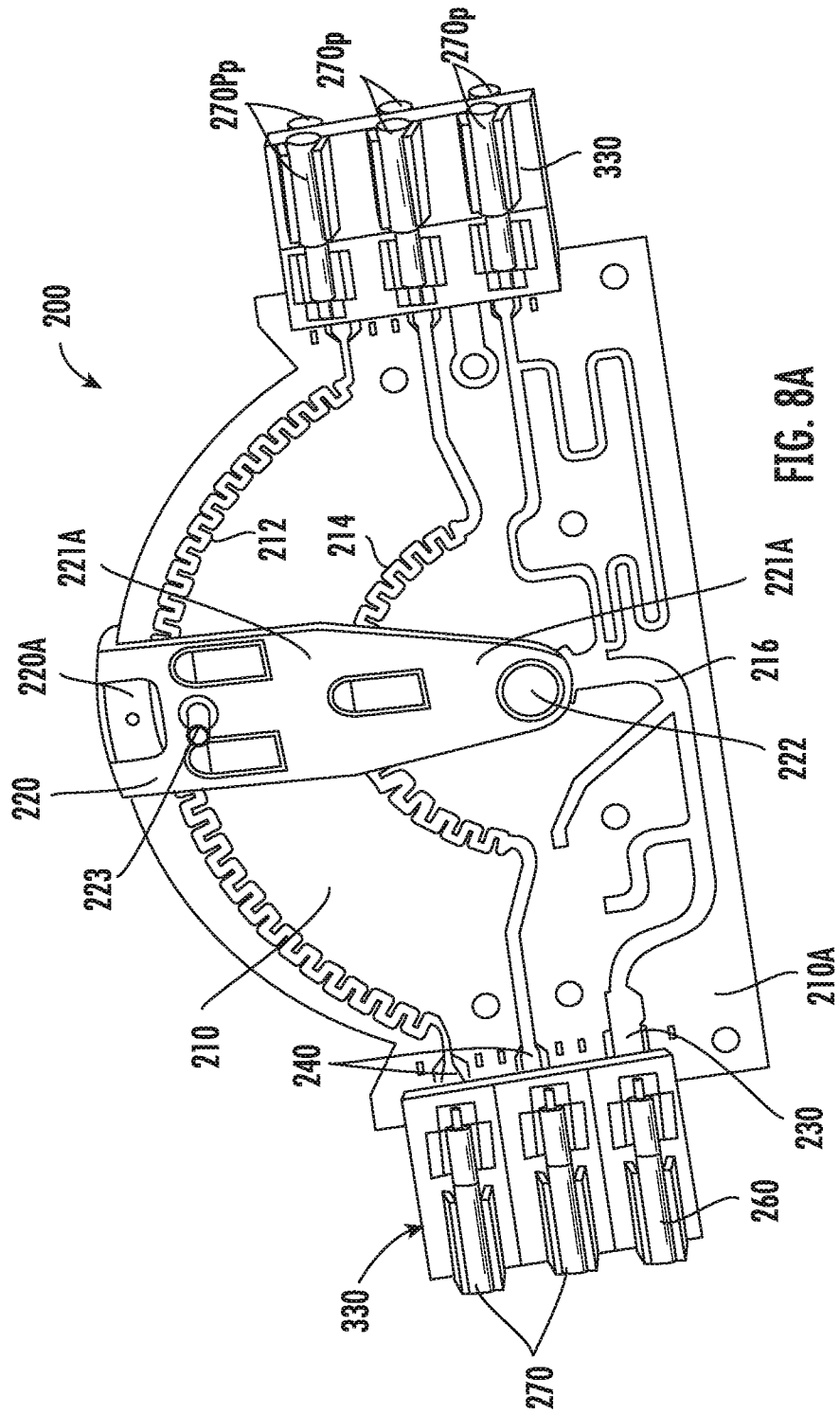

FIG. 8A

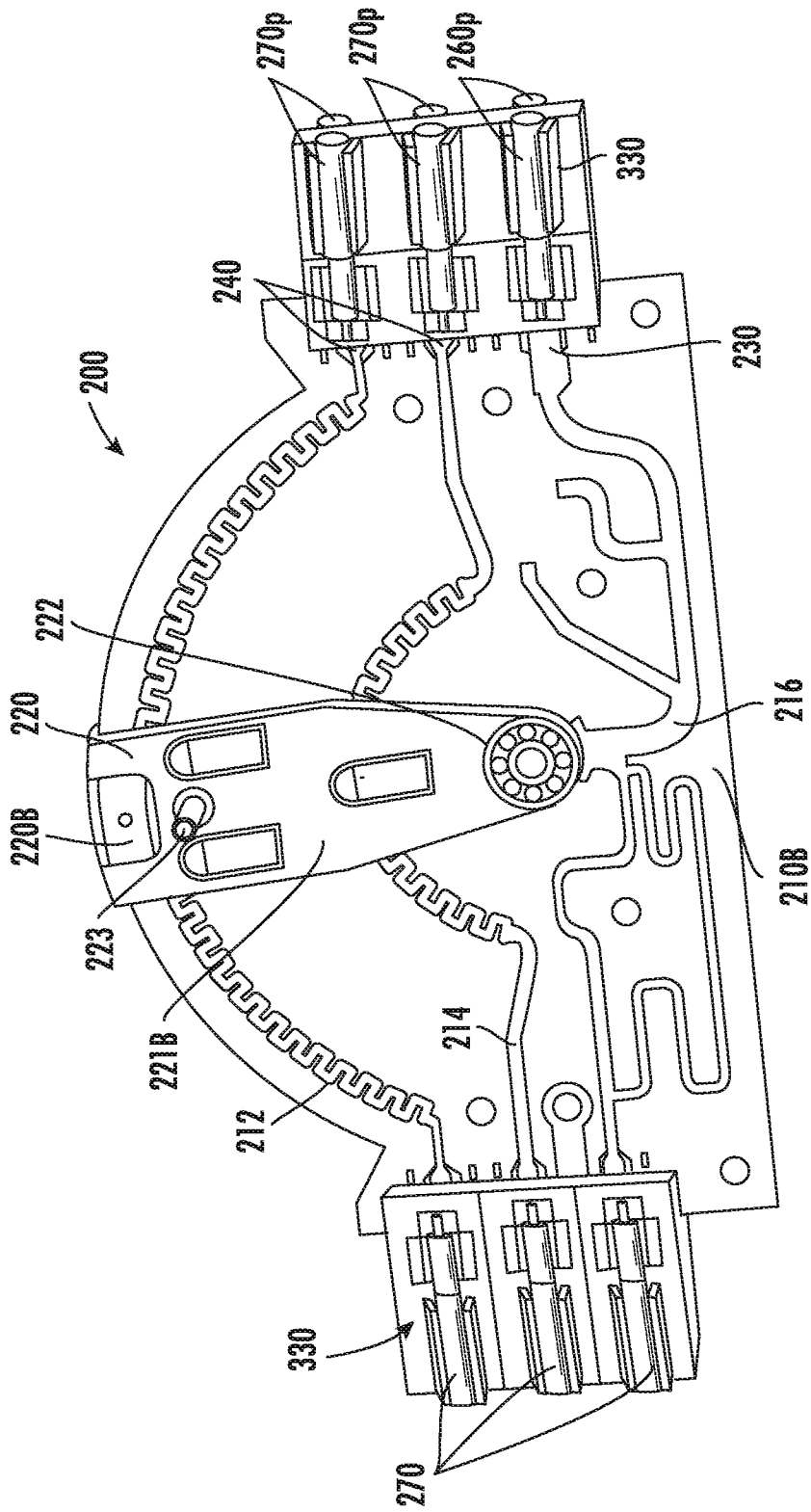

FIG. 8B

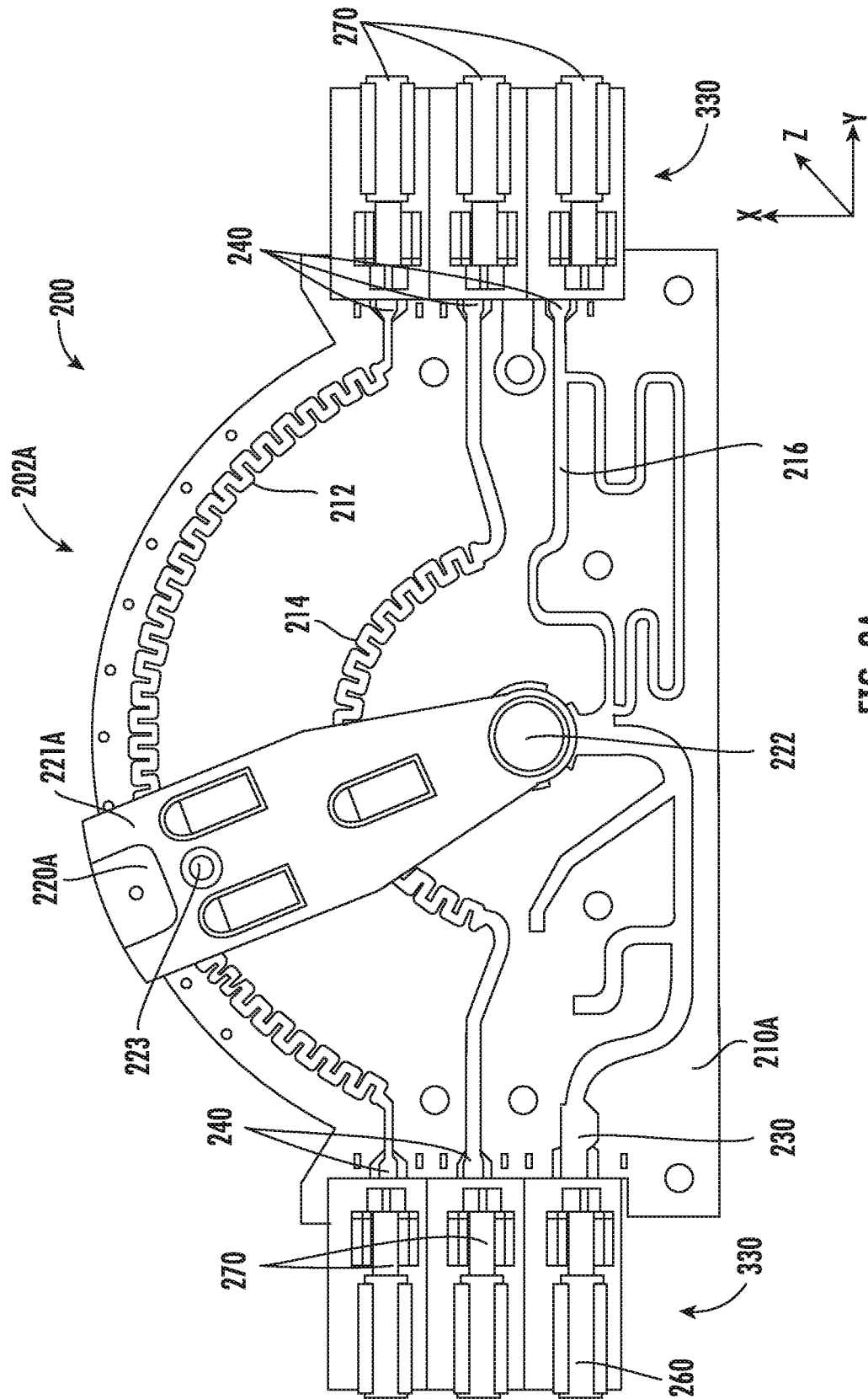

FIG. 9A

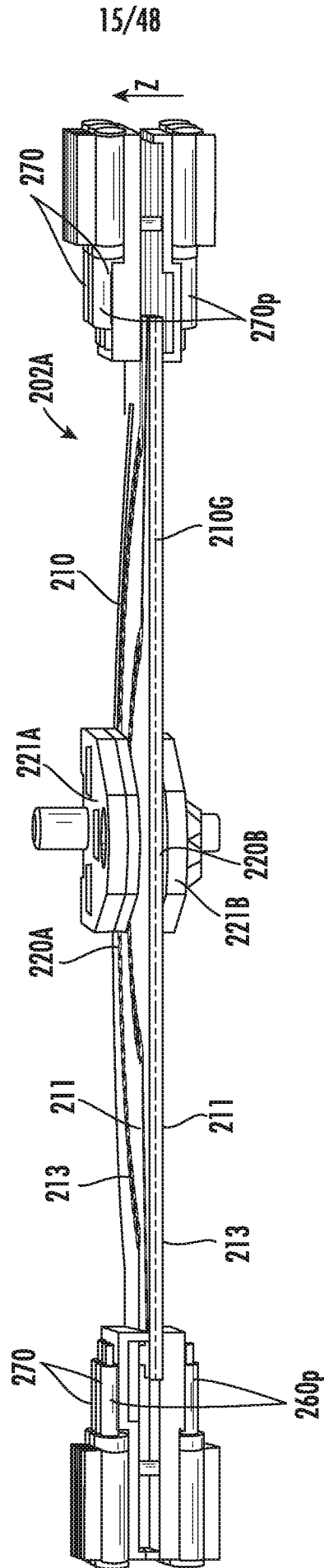

FIG. 10A

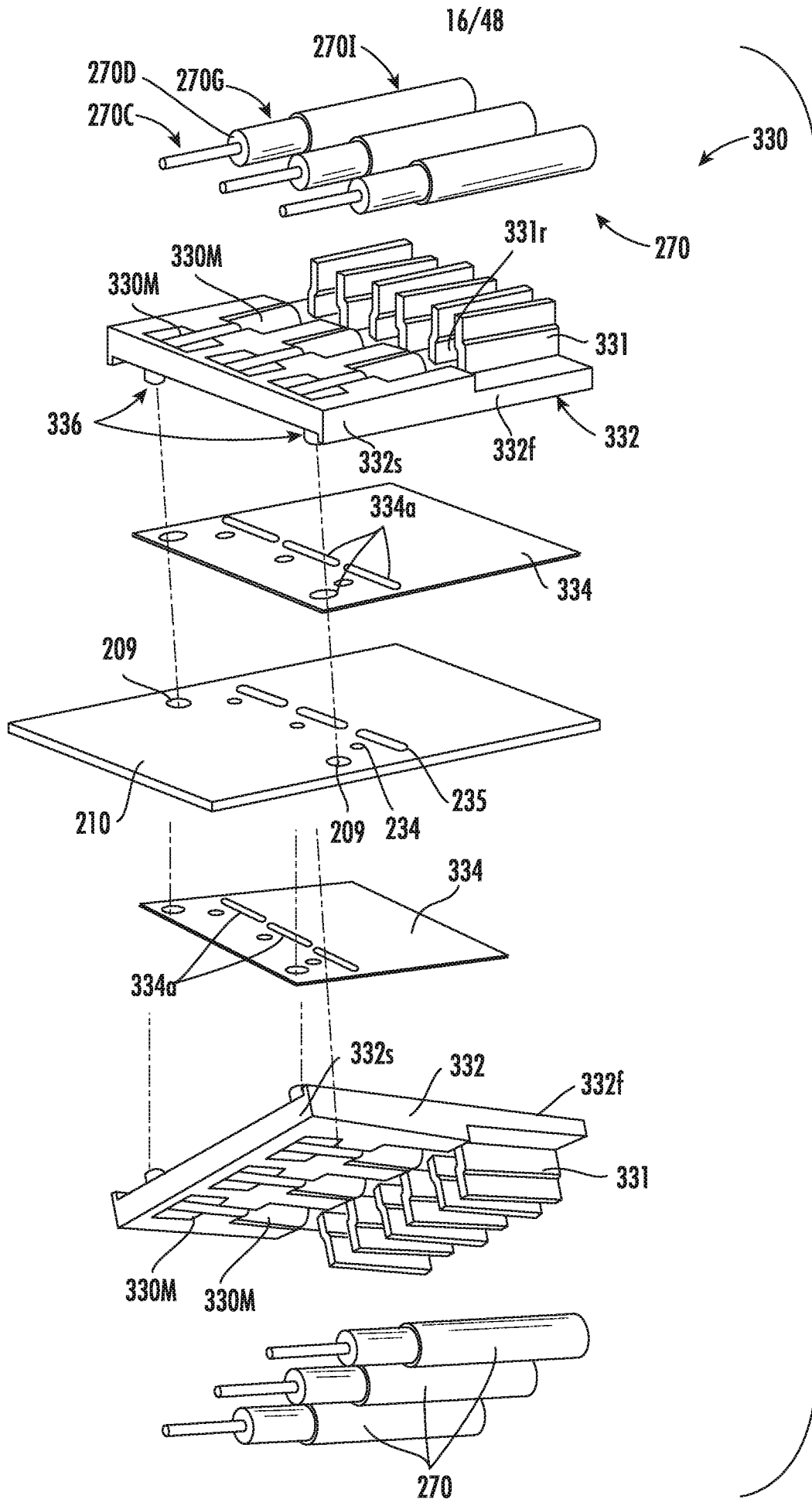

FIG. 10B

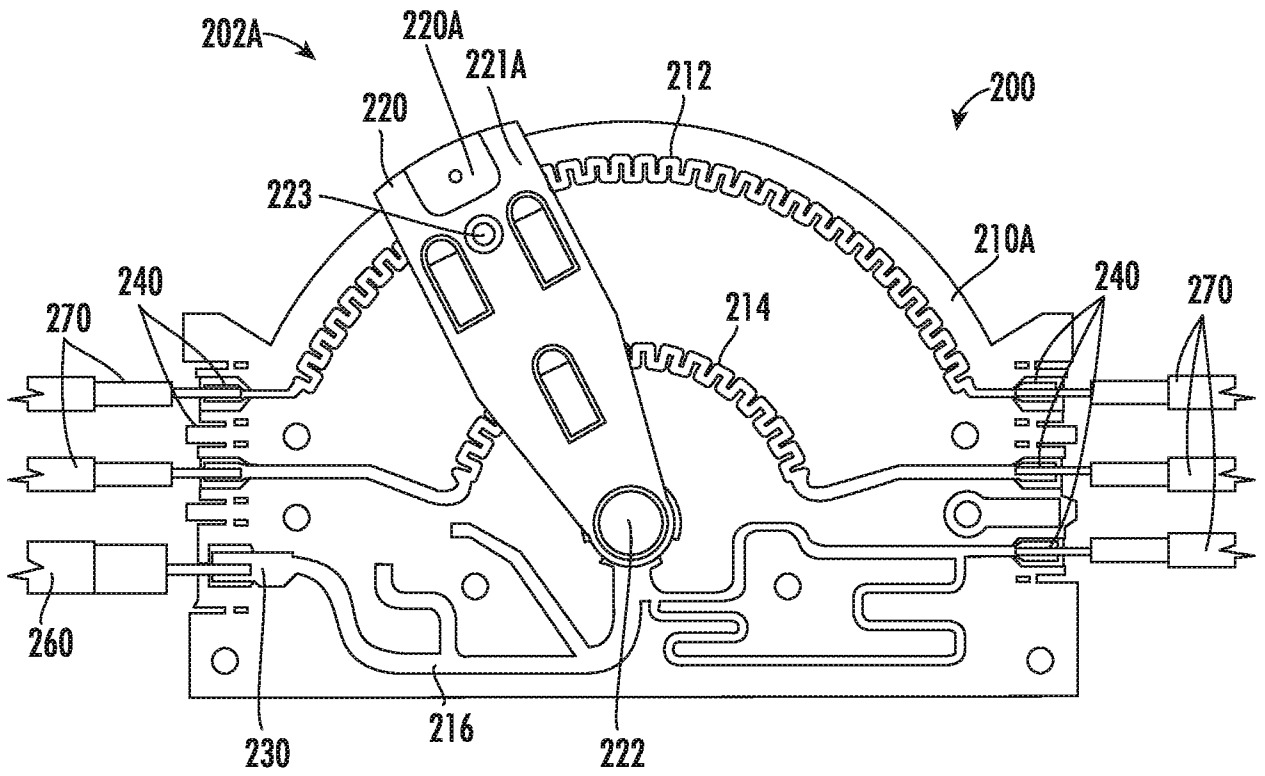

FIG. 11A

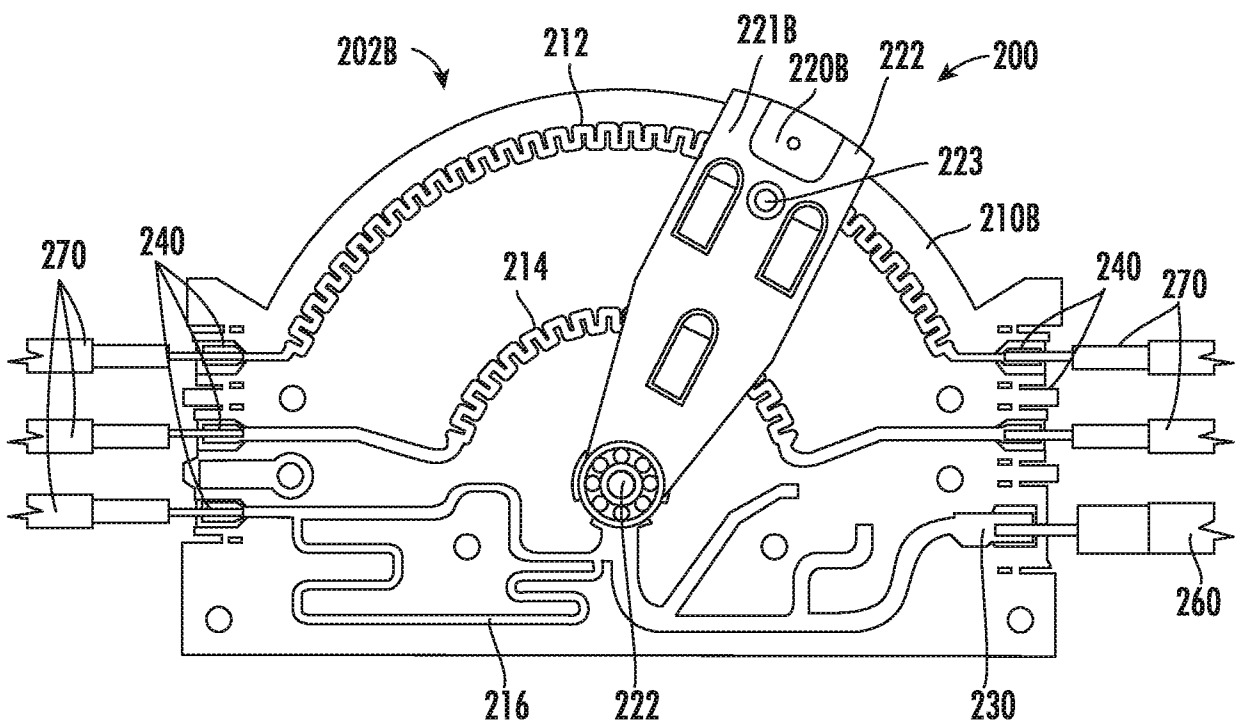

FIG. 11B

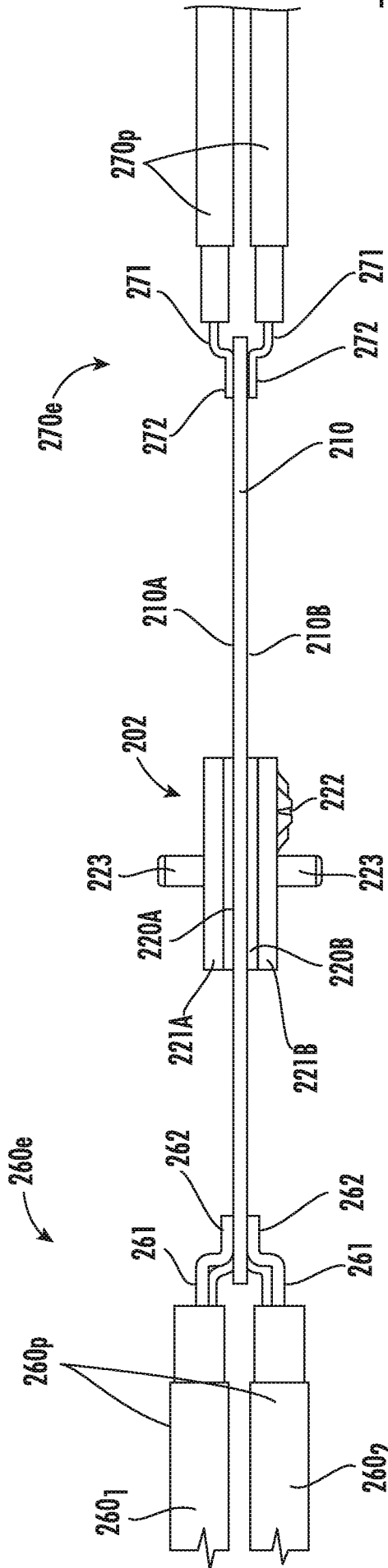

FIG. 12

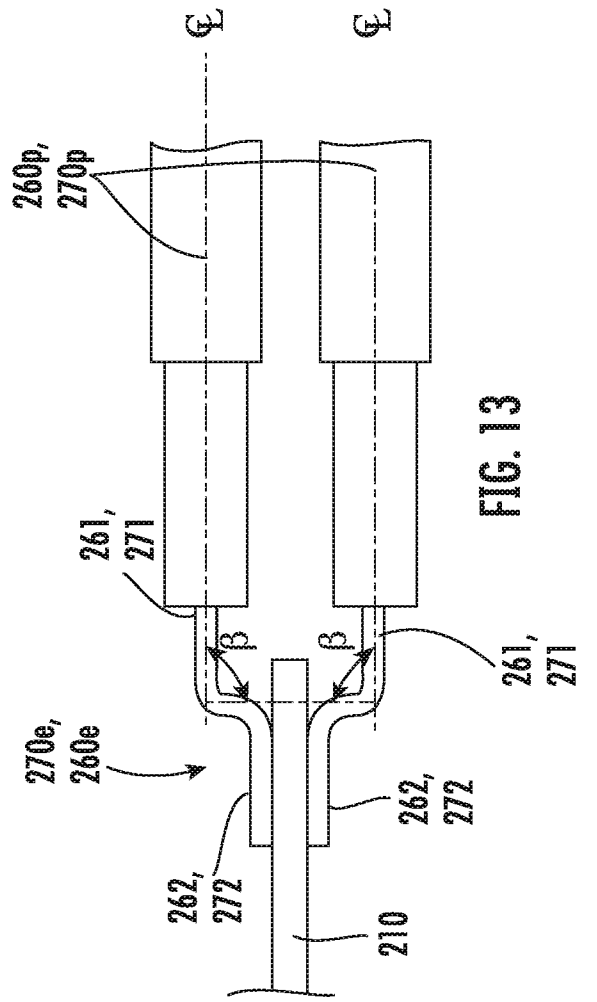

FIG. 13

20/48

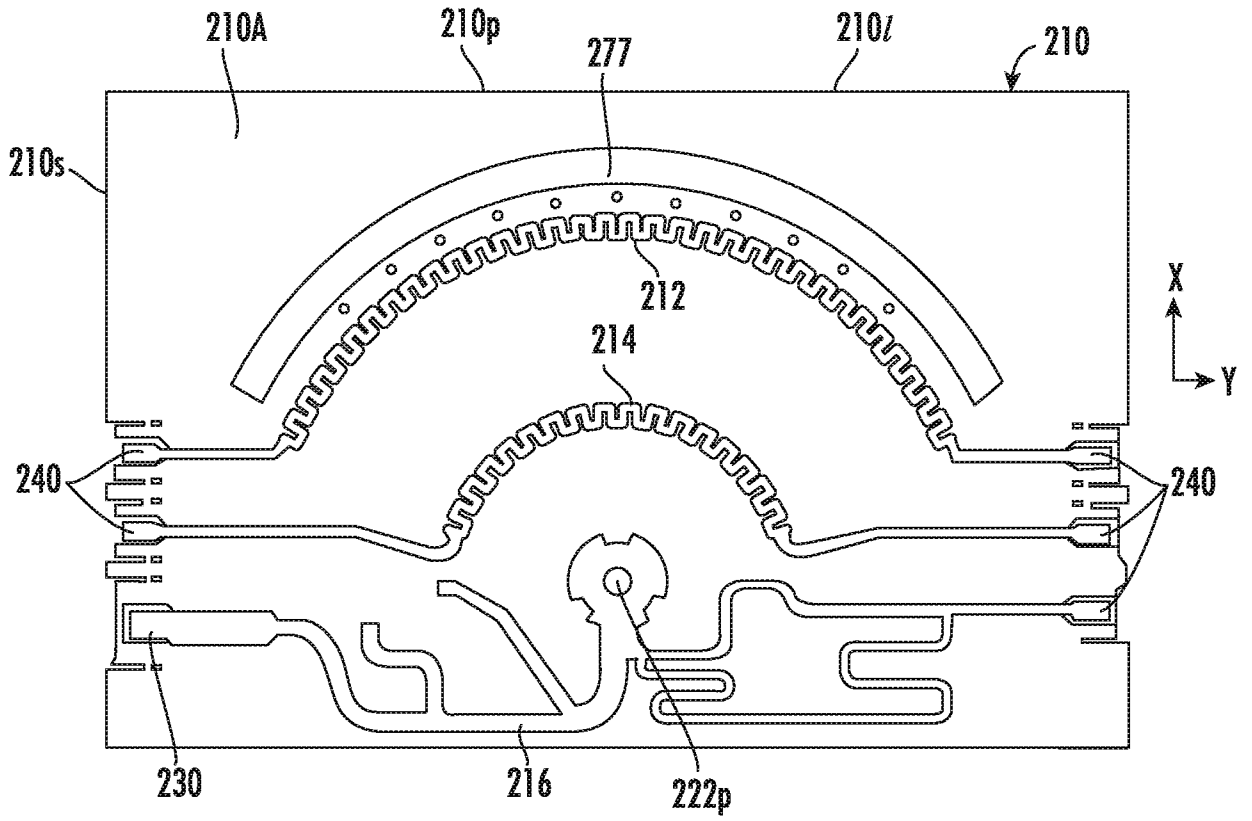

FIG. 14A

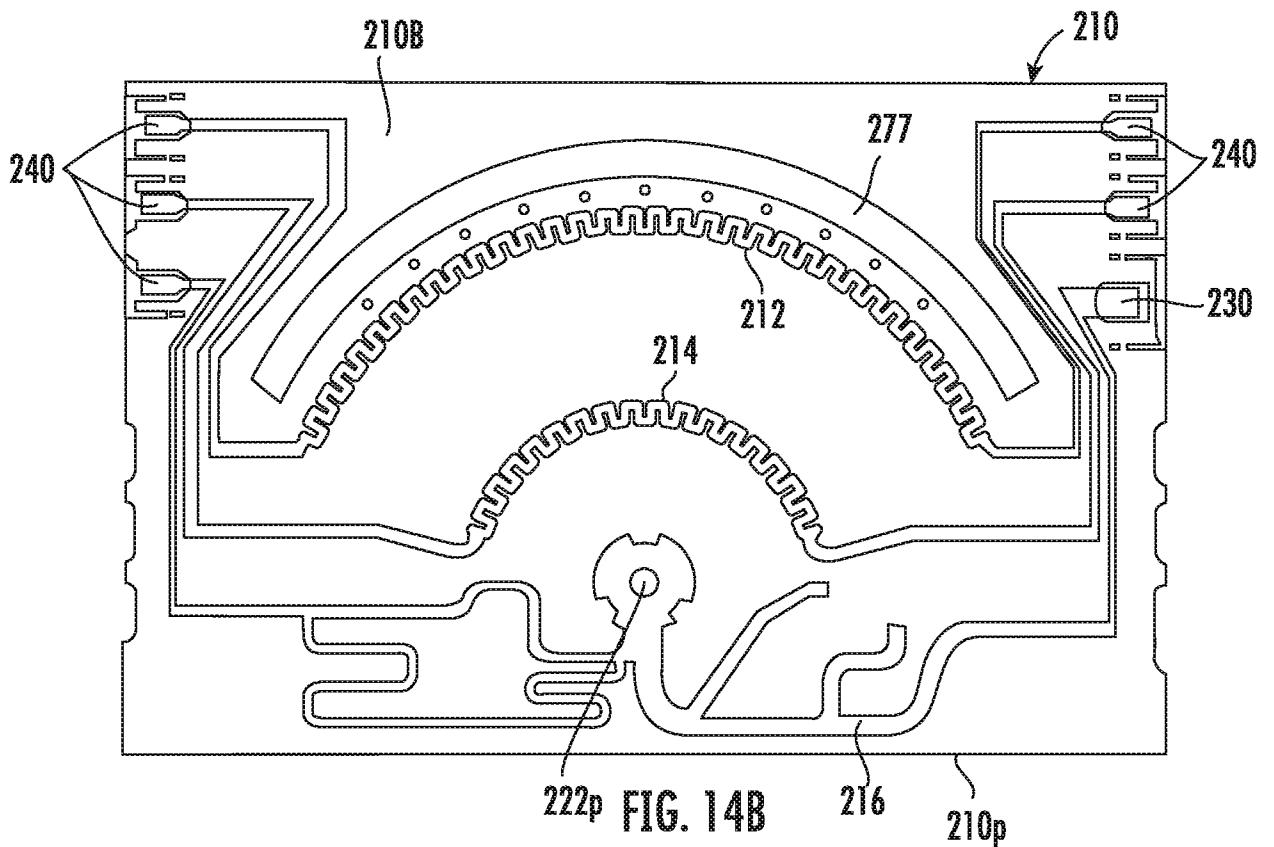

FIG. 14B

21/48

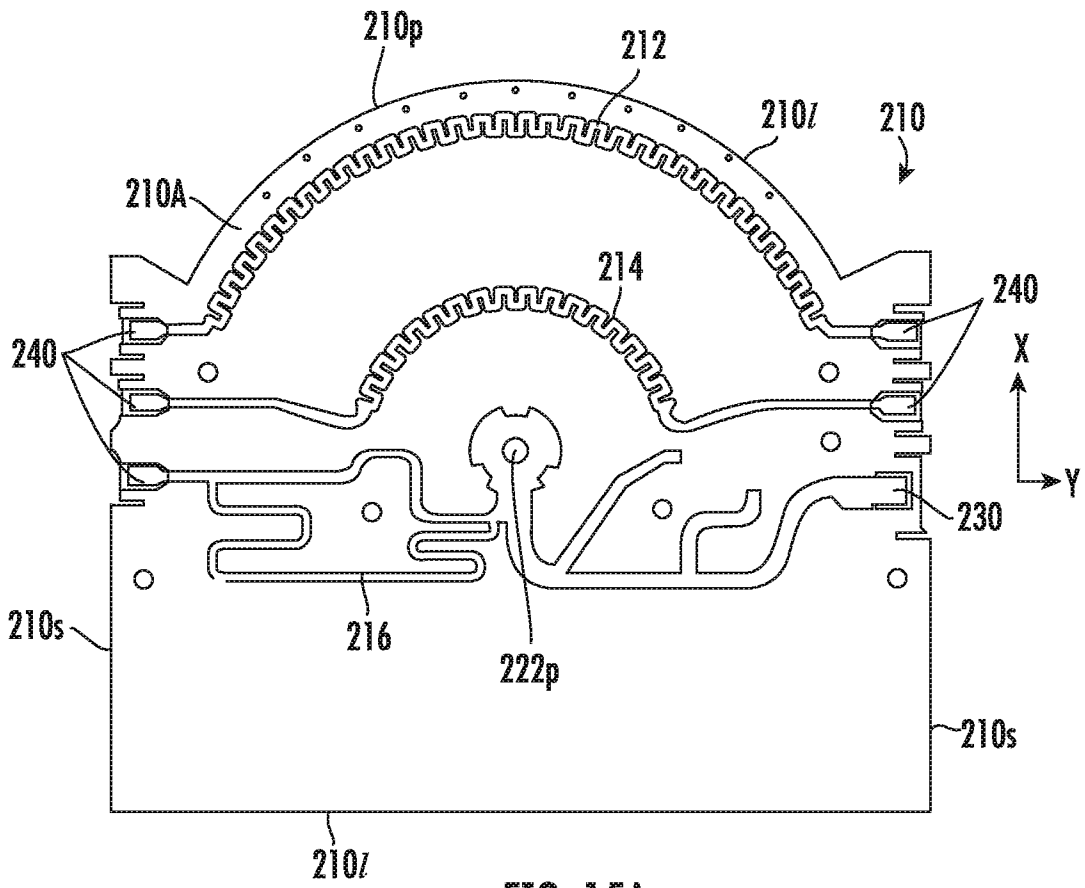

FIG. 15A

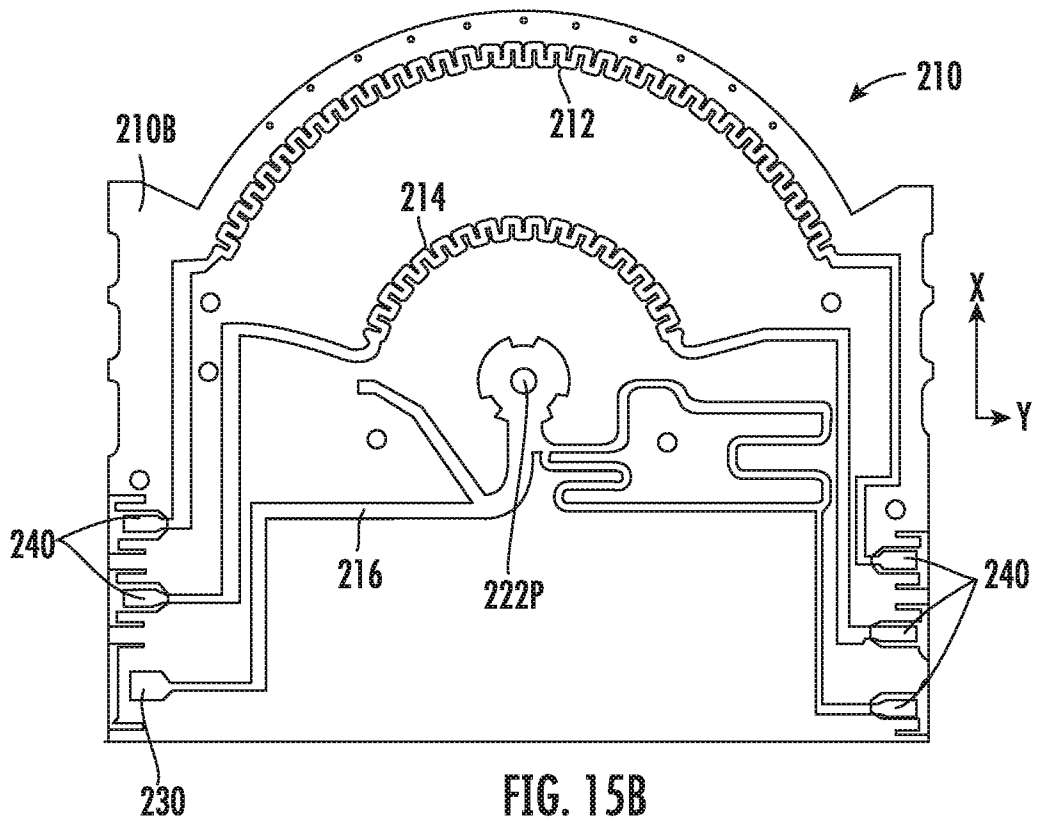

FIG. 15B

22/48

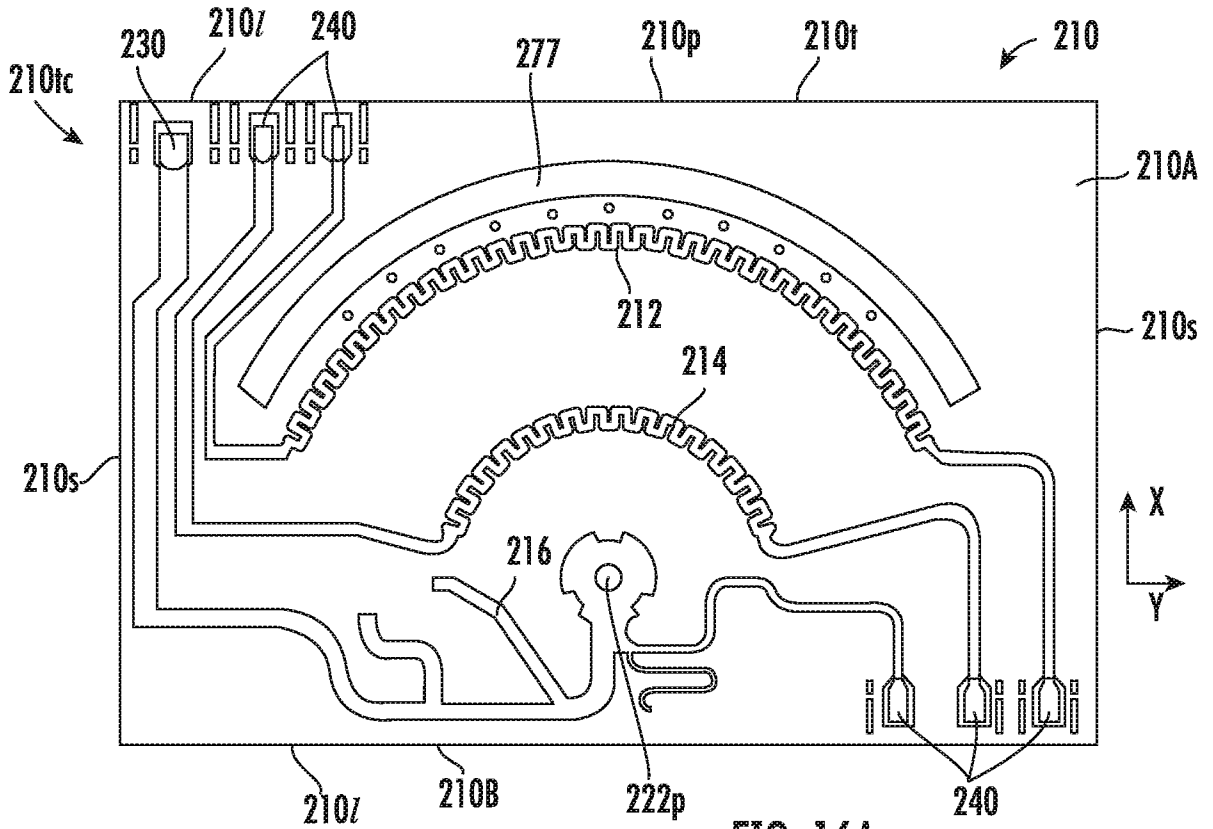

FIG. 16A

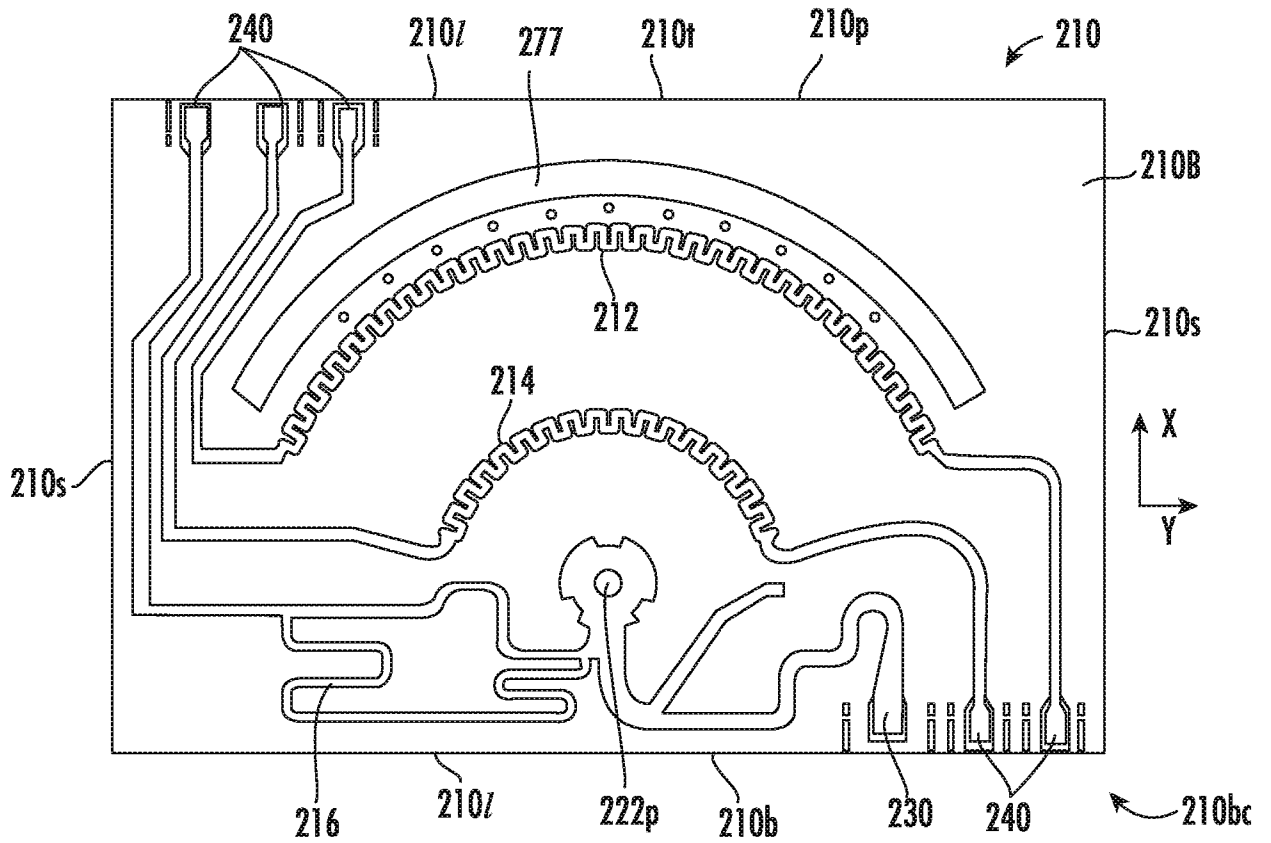

FIG. 16B

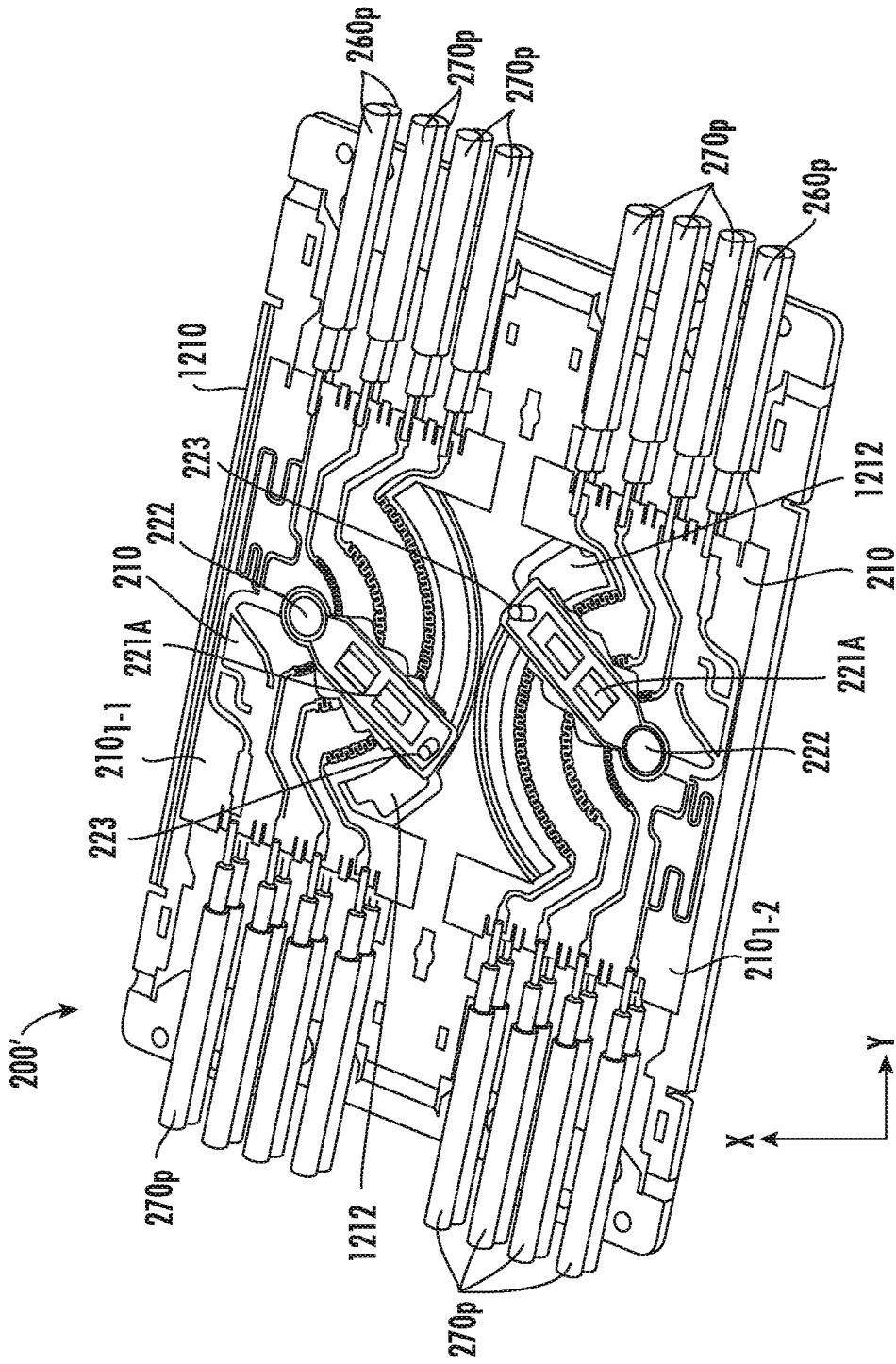

FIG. 17A

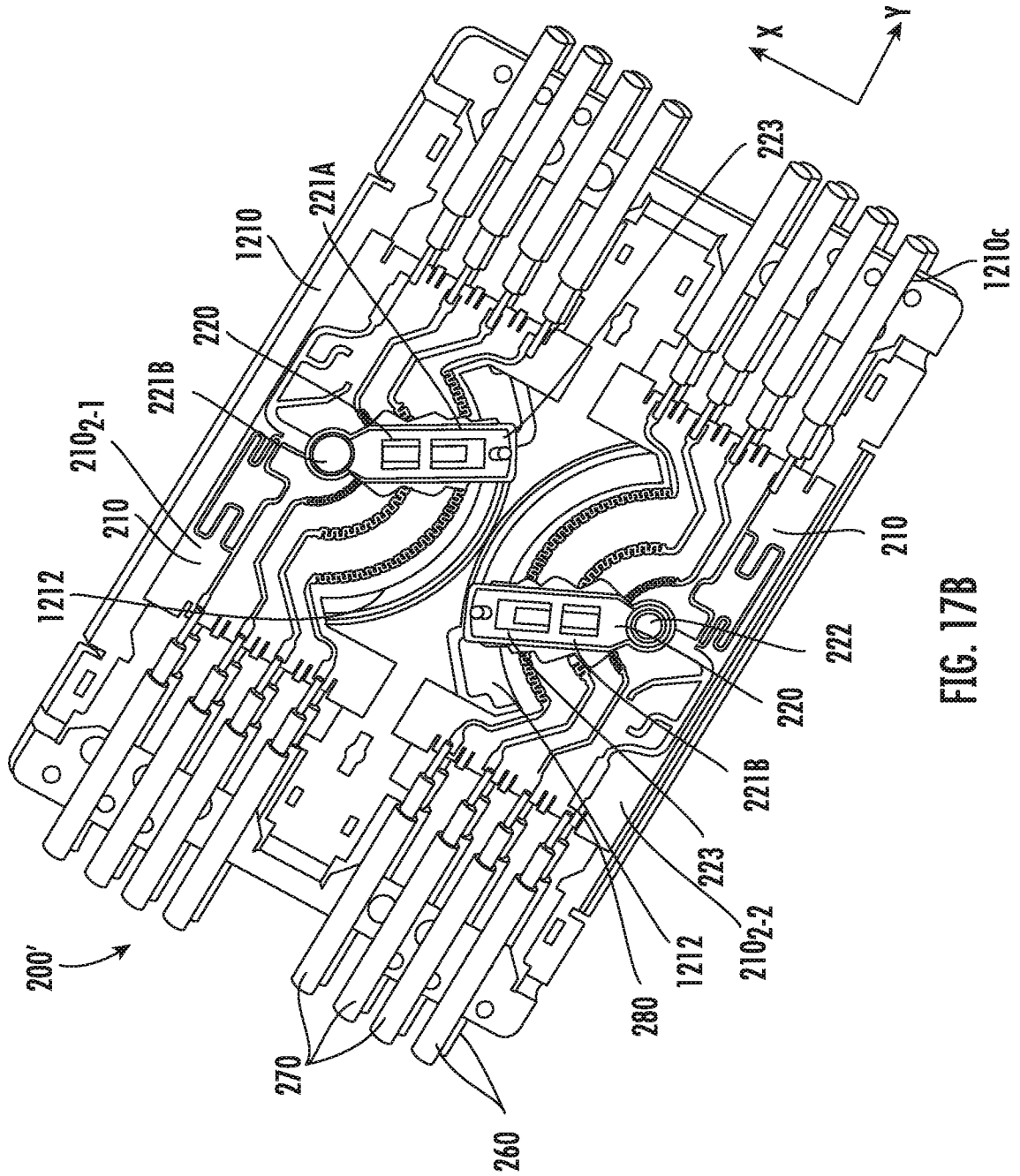

FIG. 17B

25/48

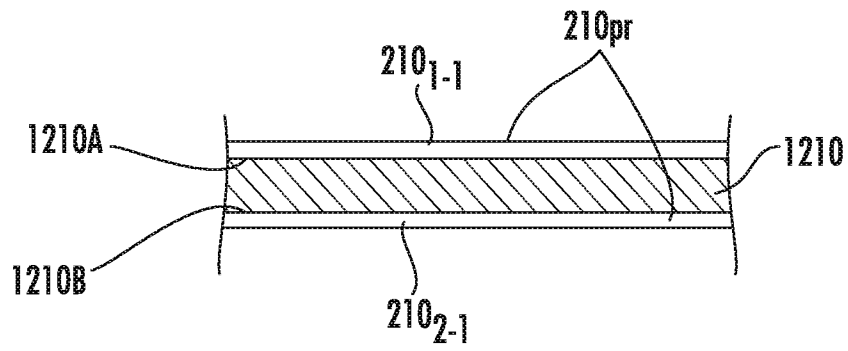

FIG. 17C

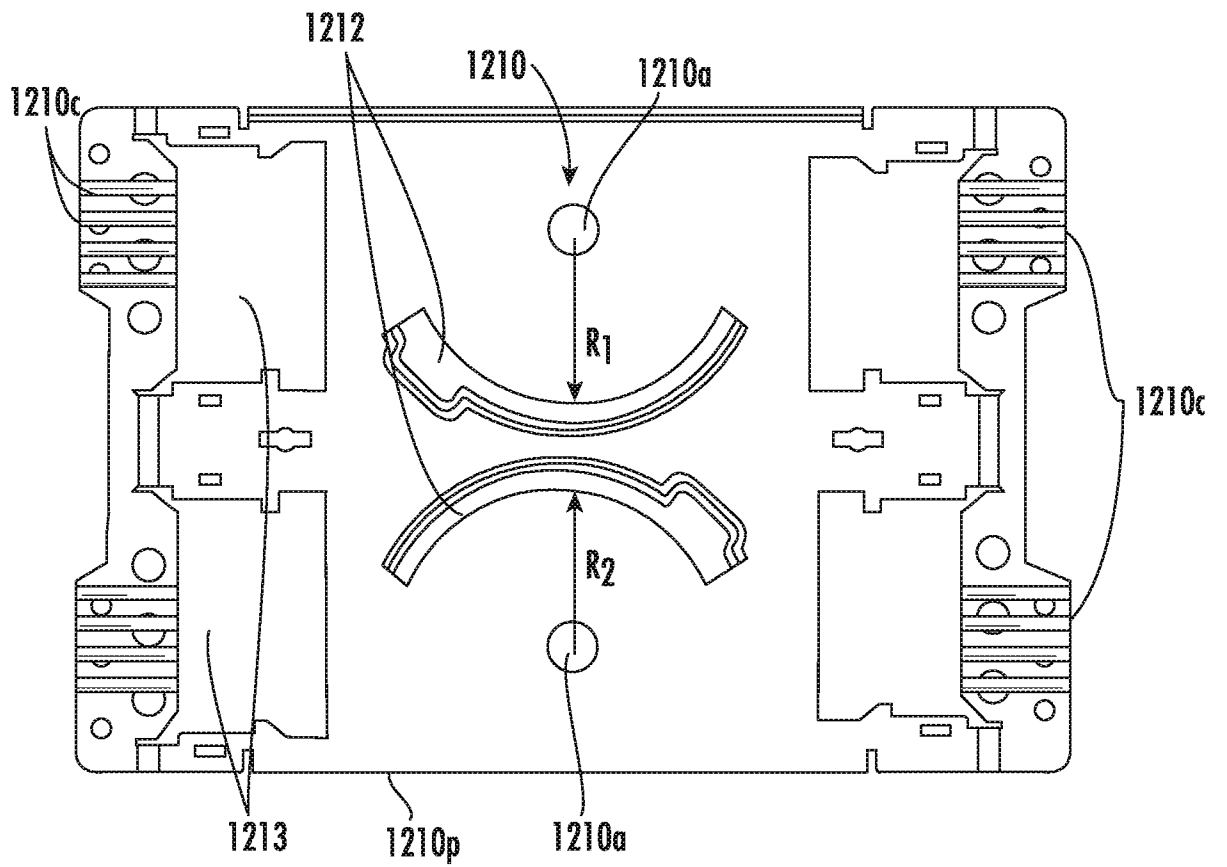

FIG. 17D

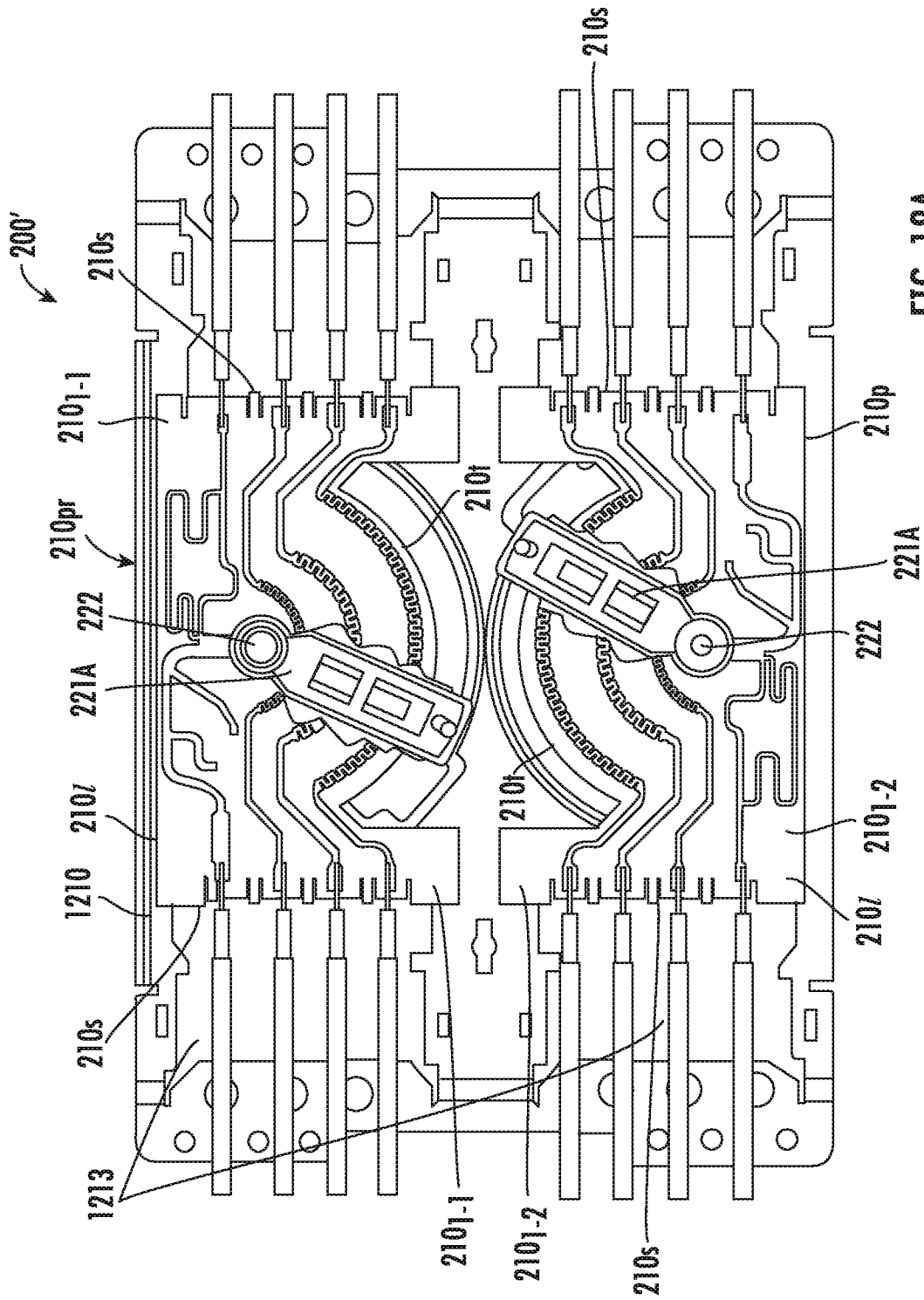

FIG. 18A

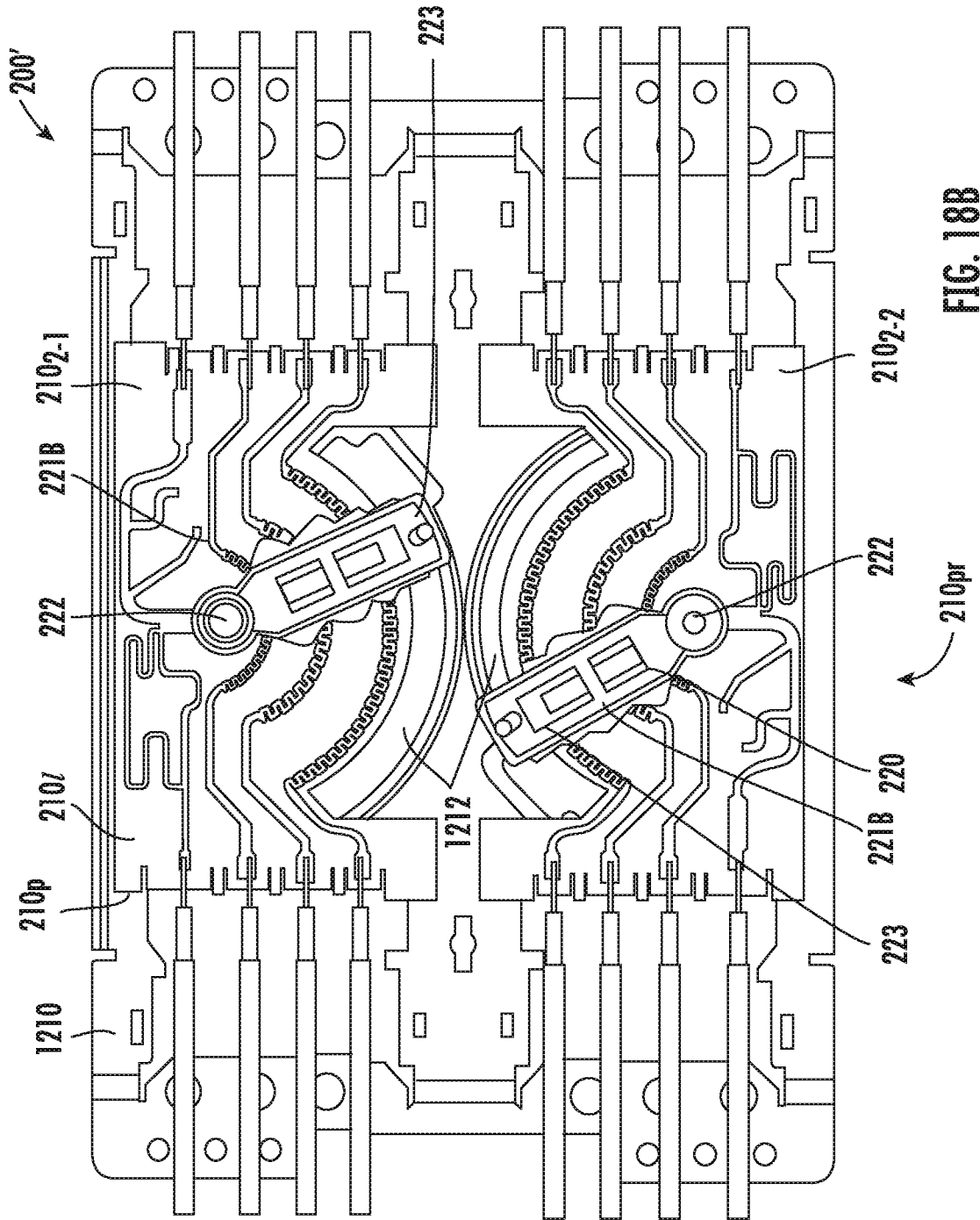
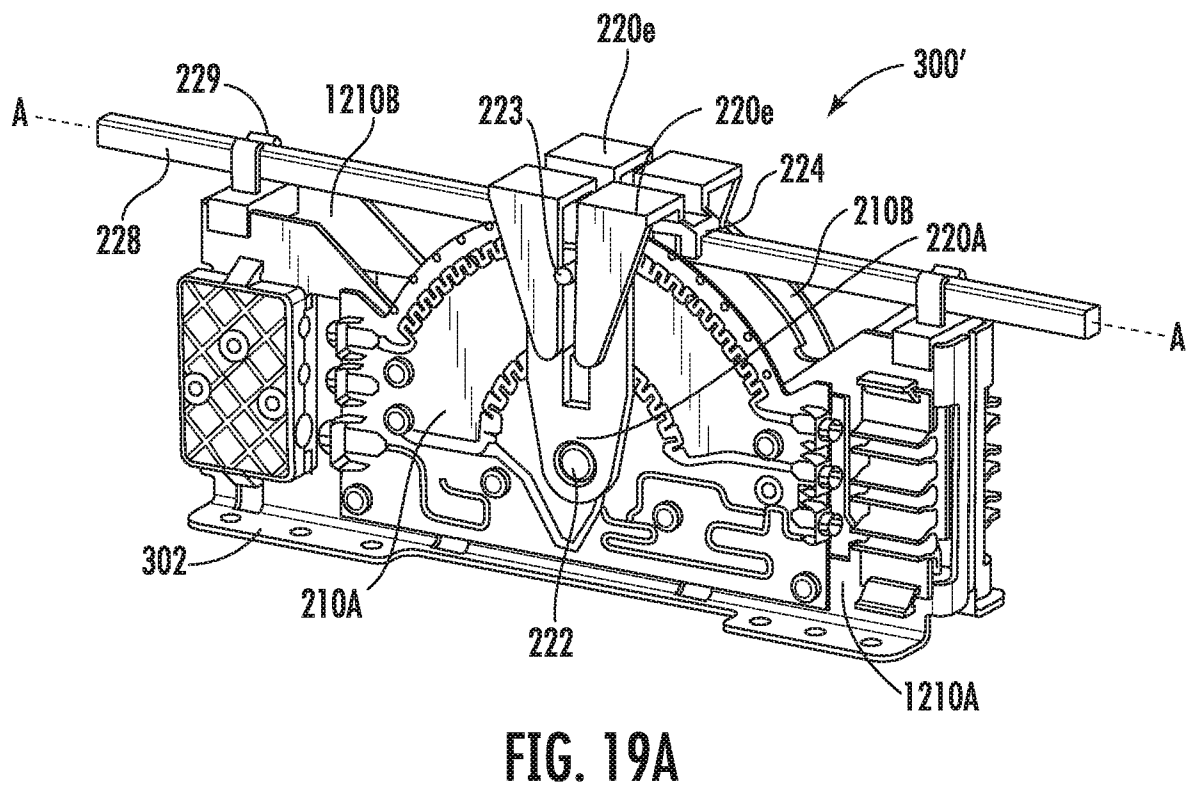
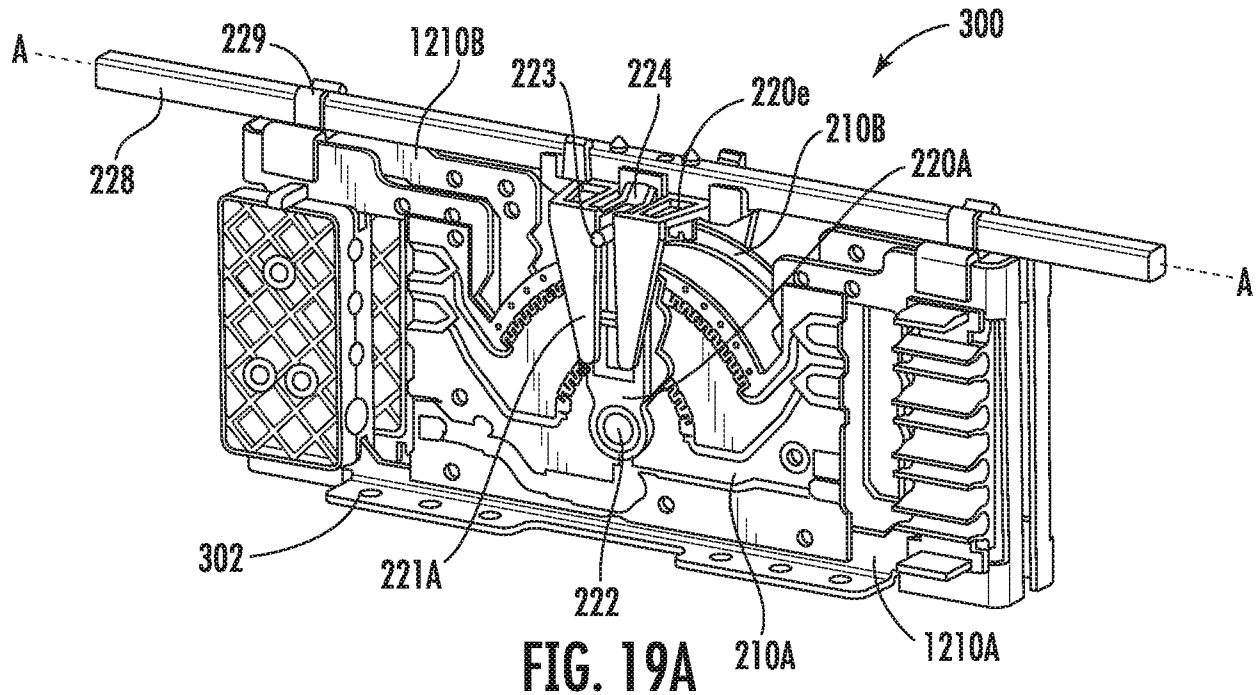

FIG. 18B



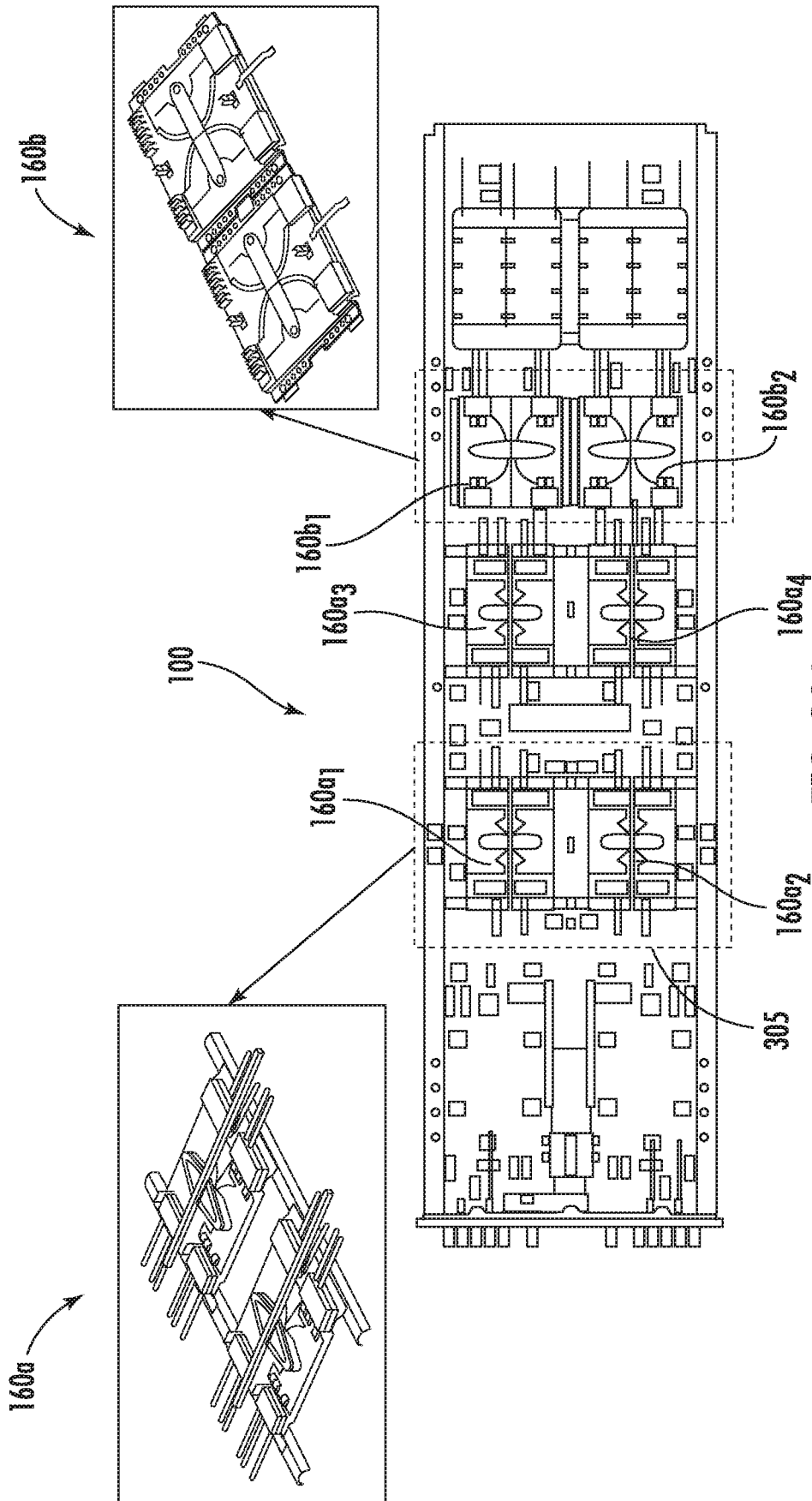

FIG. 20A

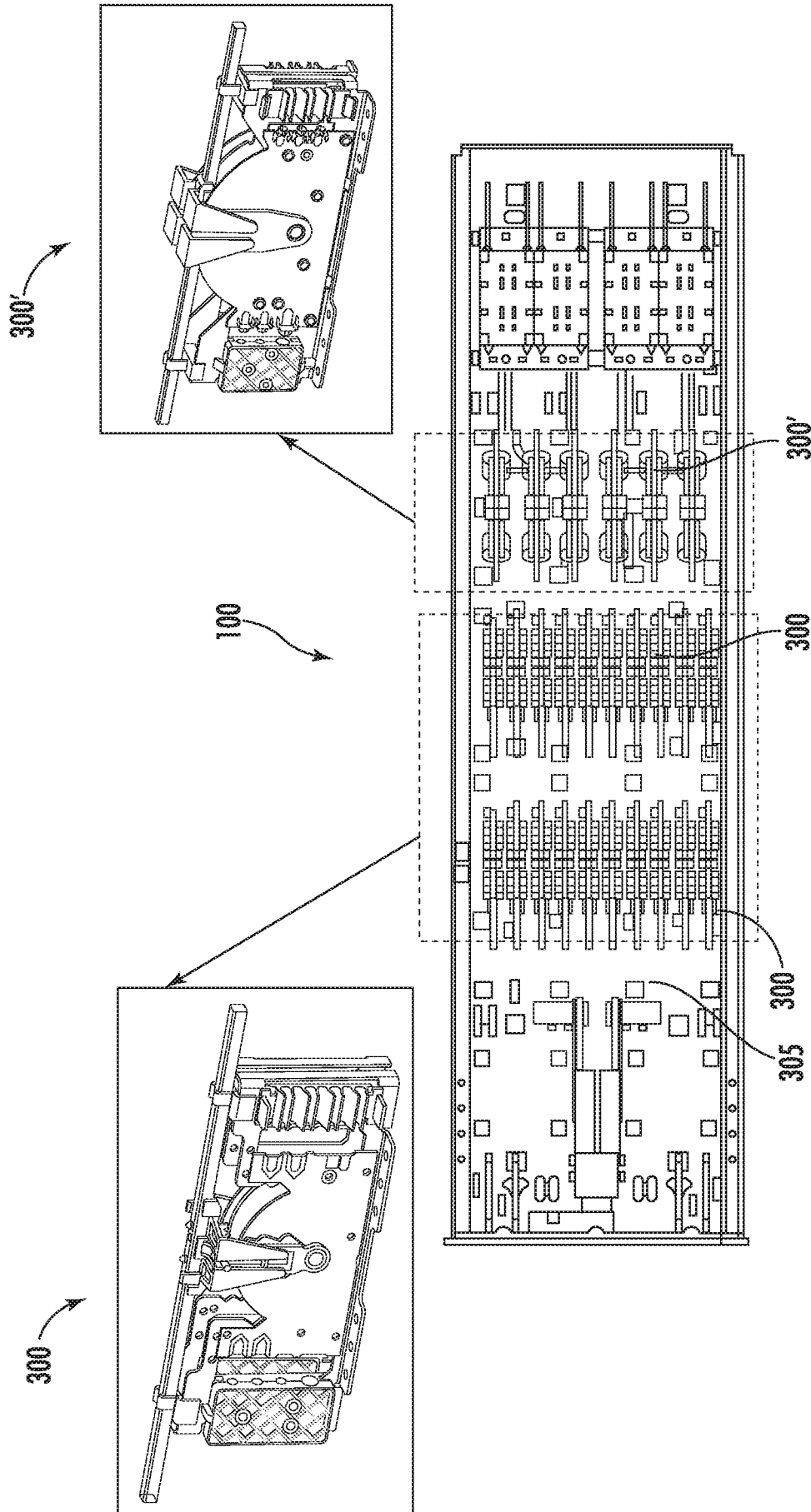
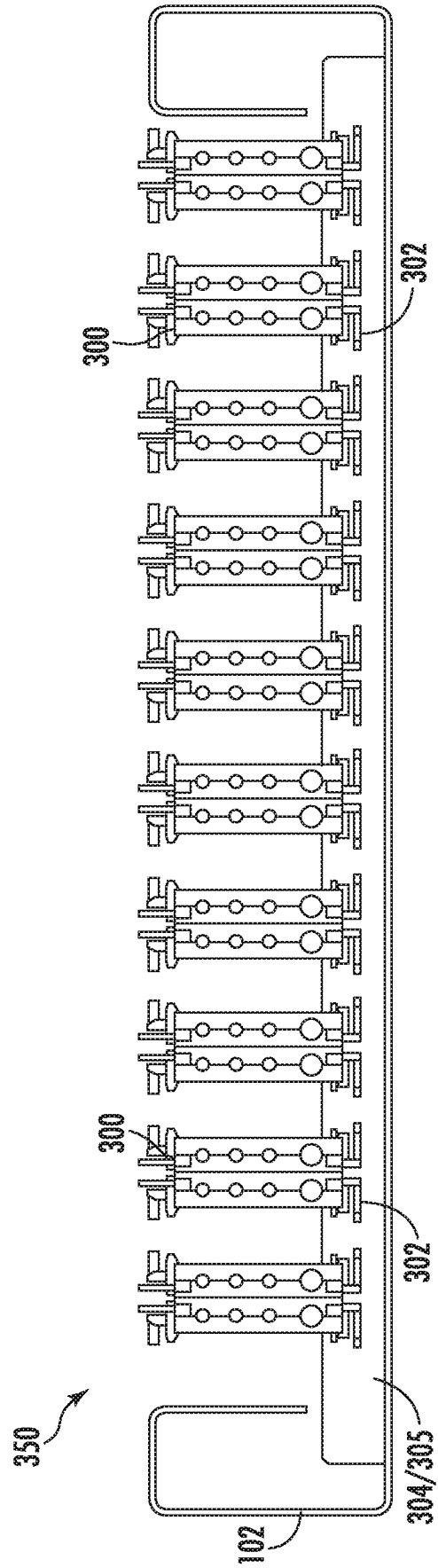
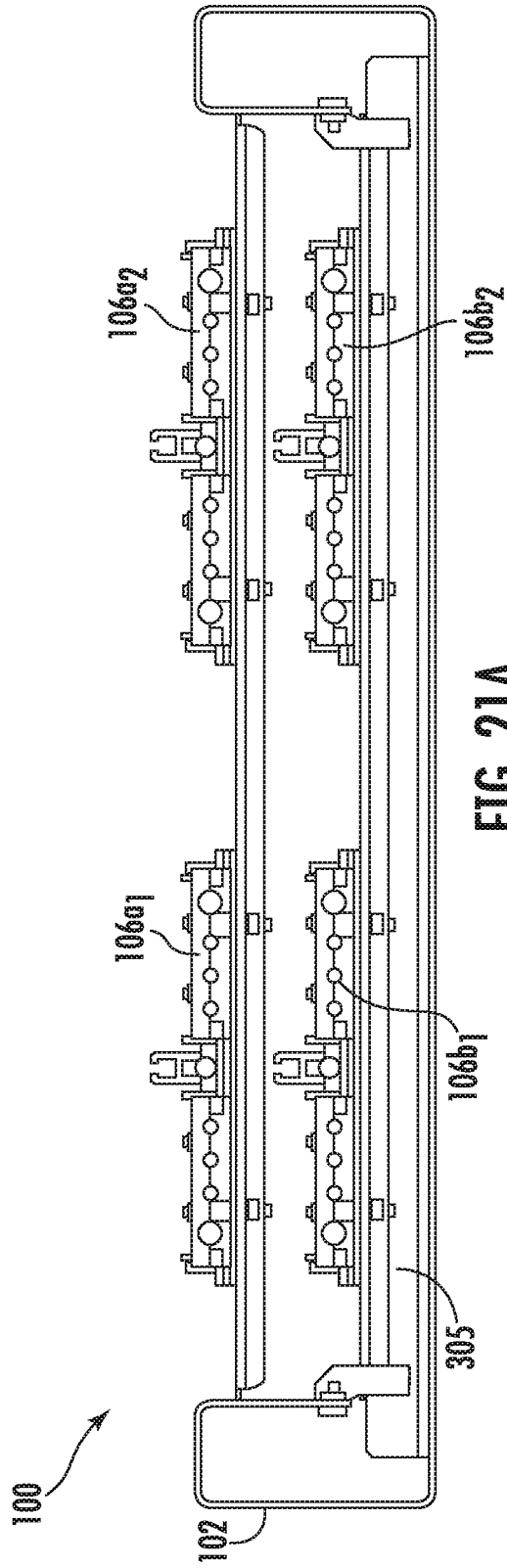

FIG. 20B



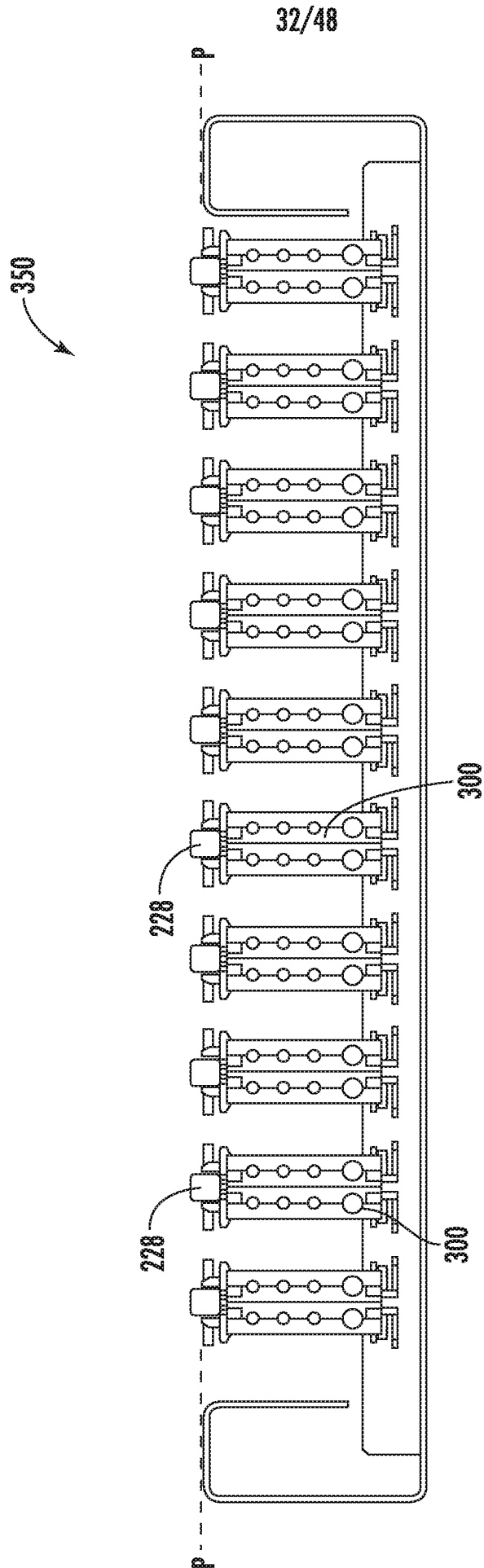

FIG. 22

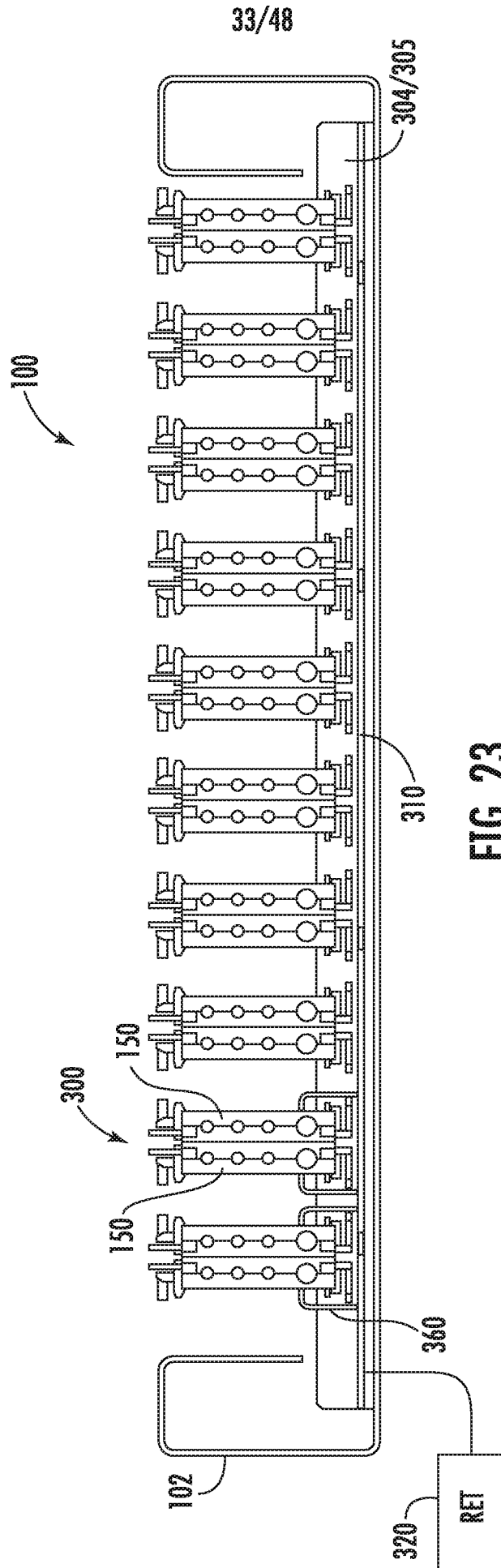

FIG. 23

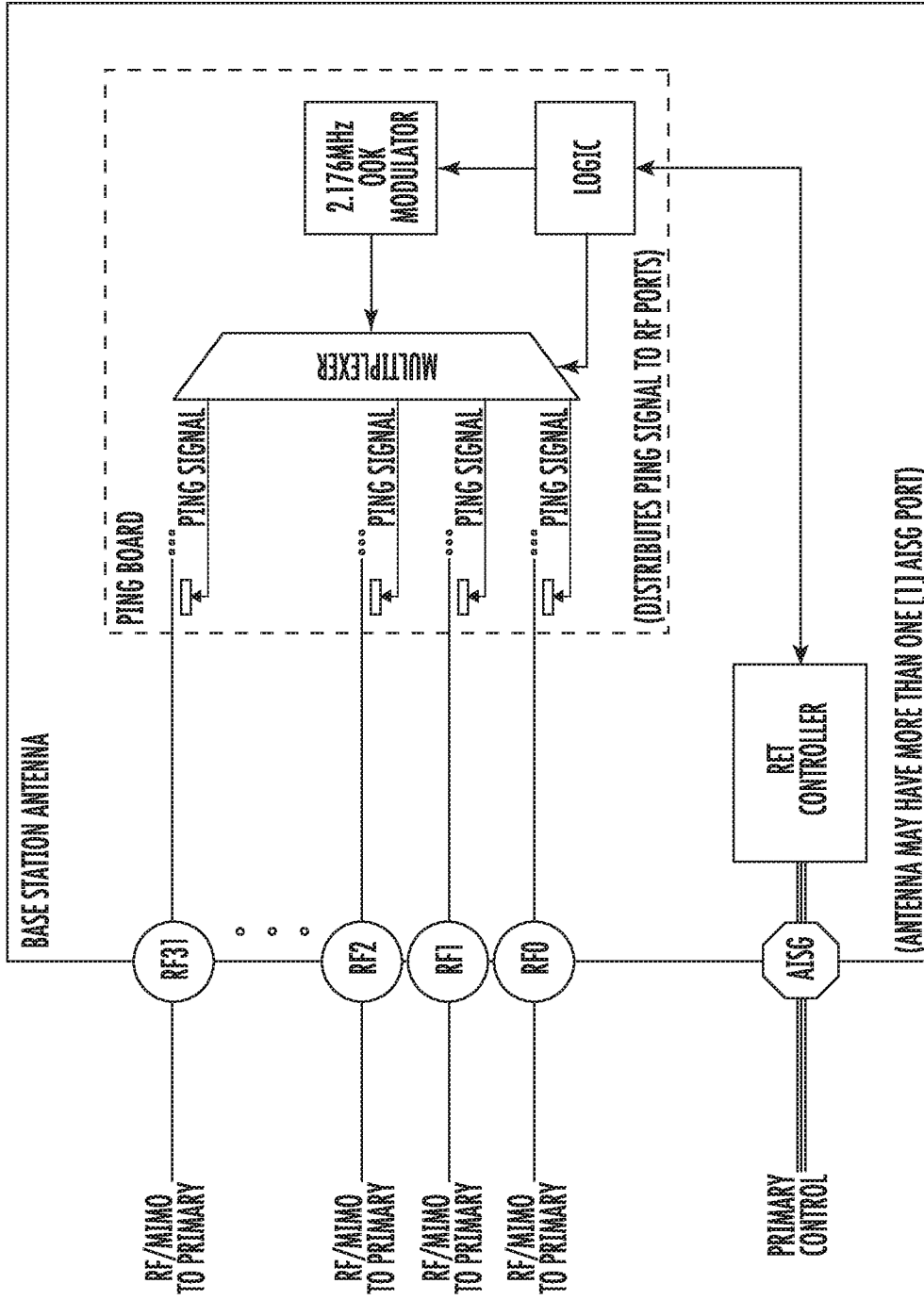

FIG. 24

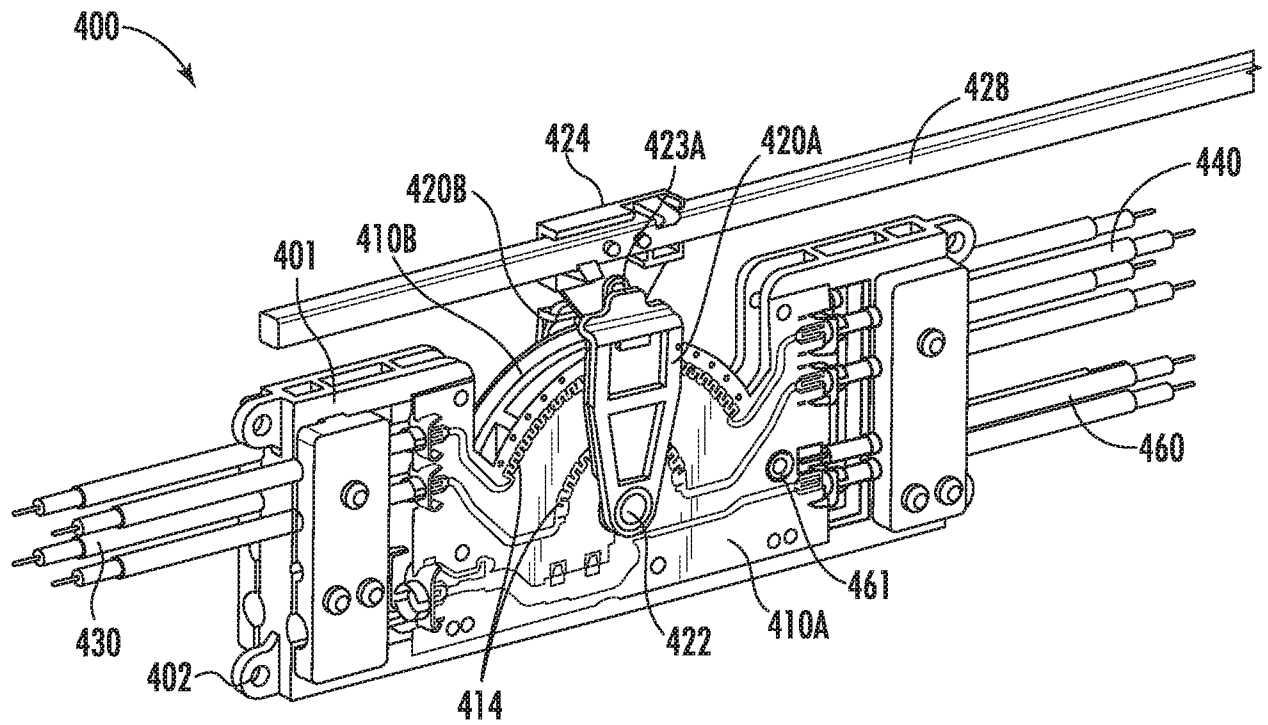

FIG. 26A

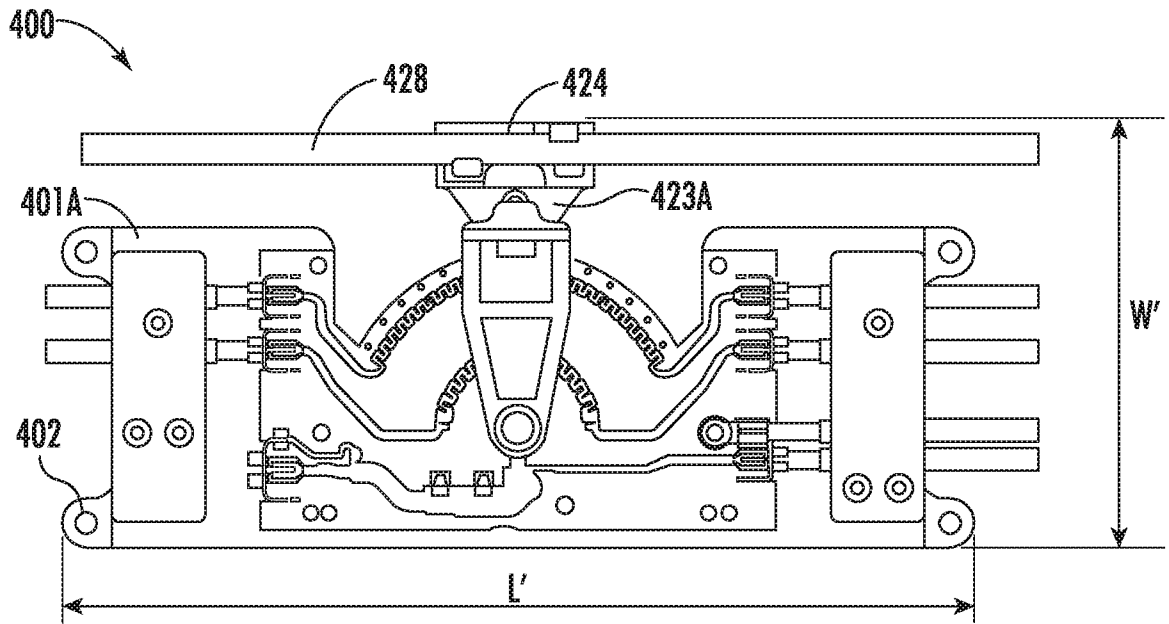

FIG. 26B

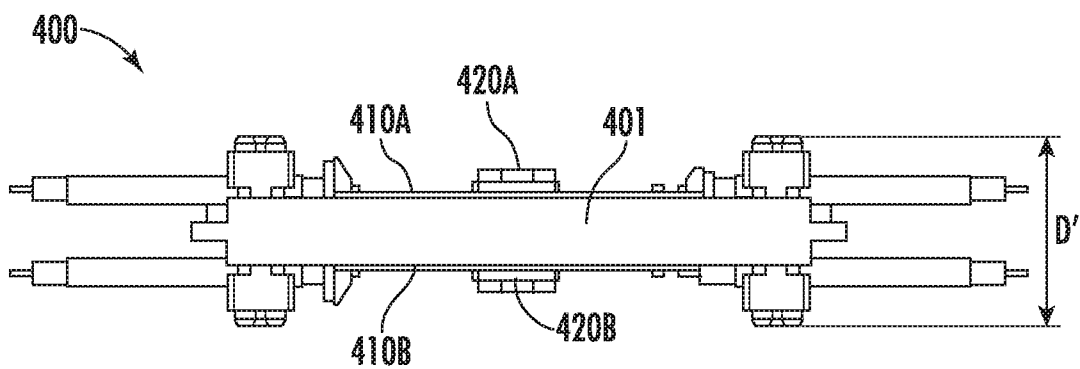

FIG. 26C

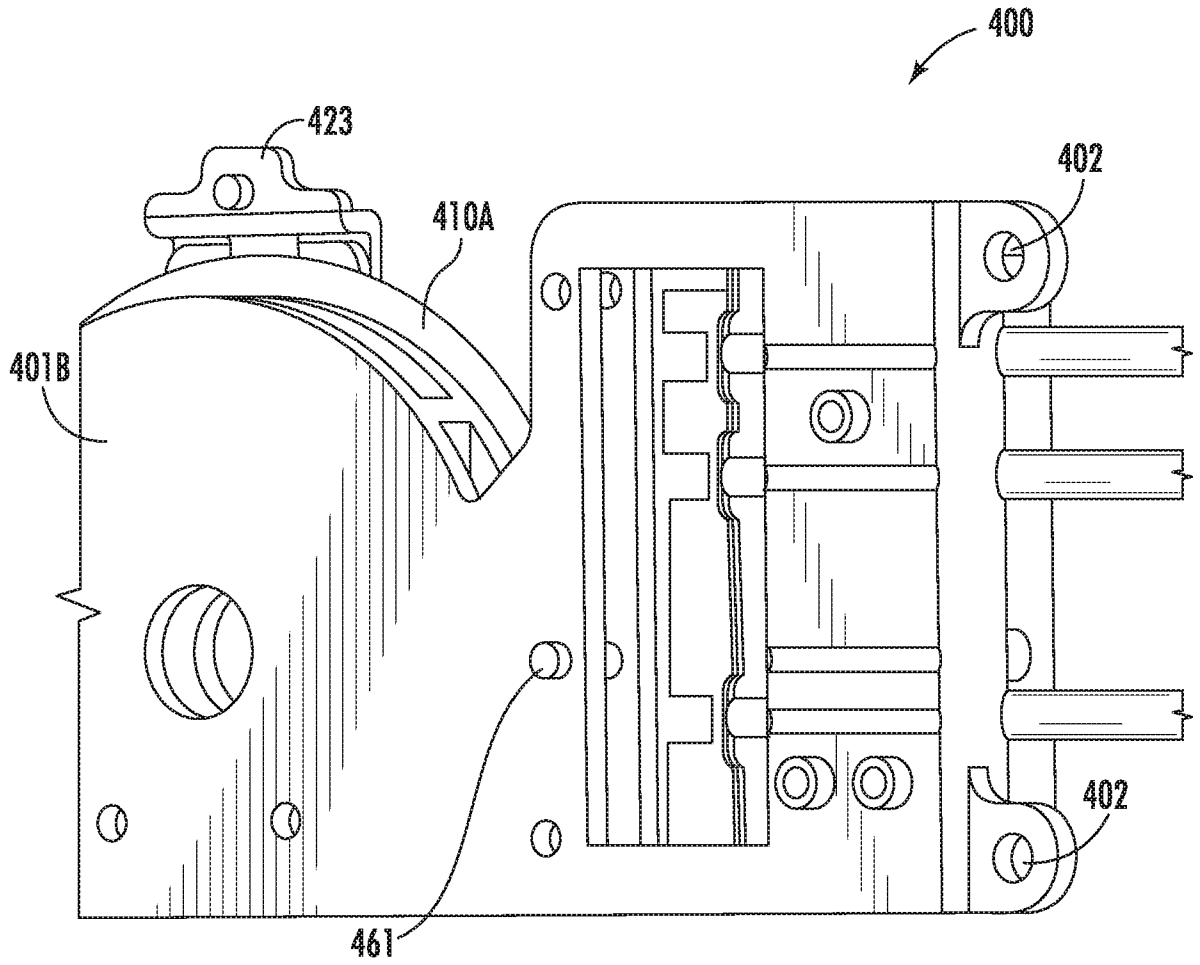

FIG. 27

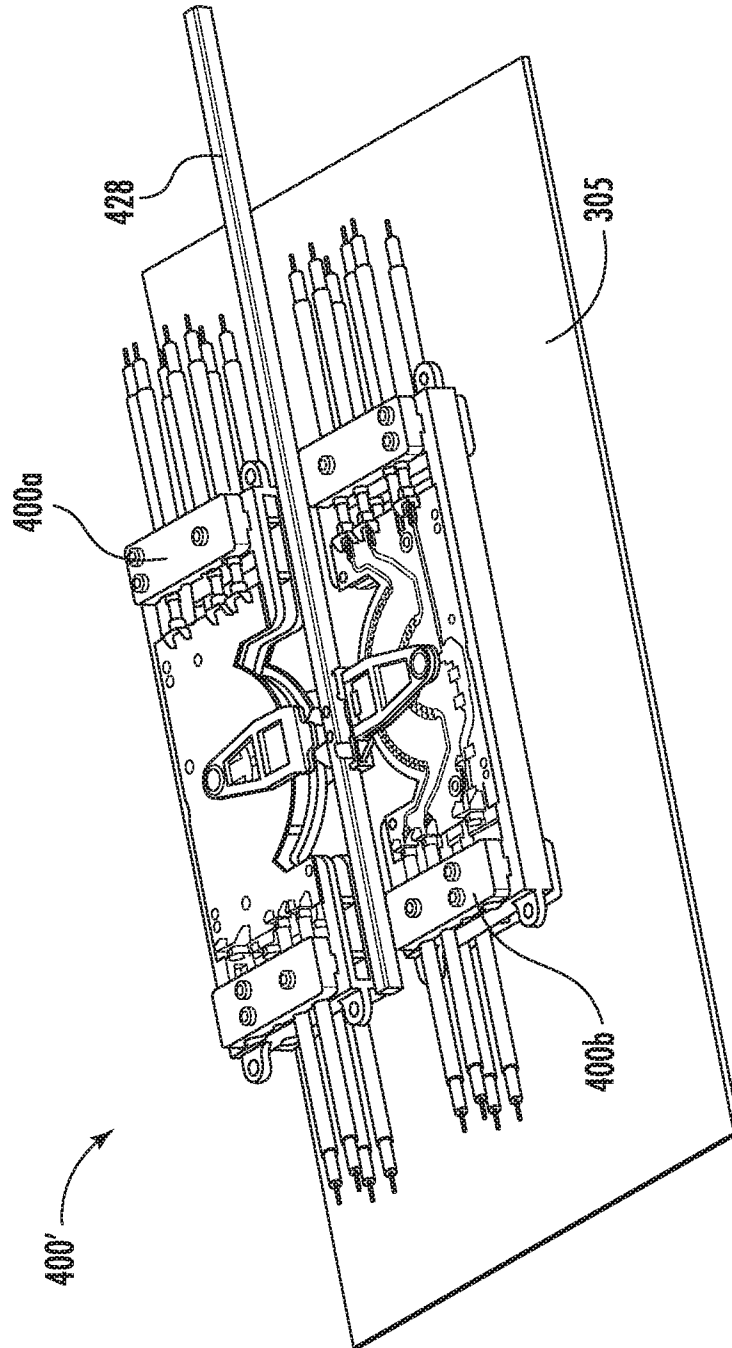

FIG. 28

40/48

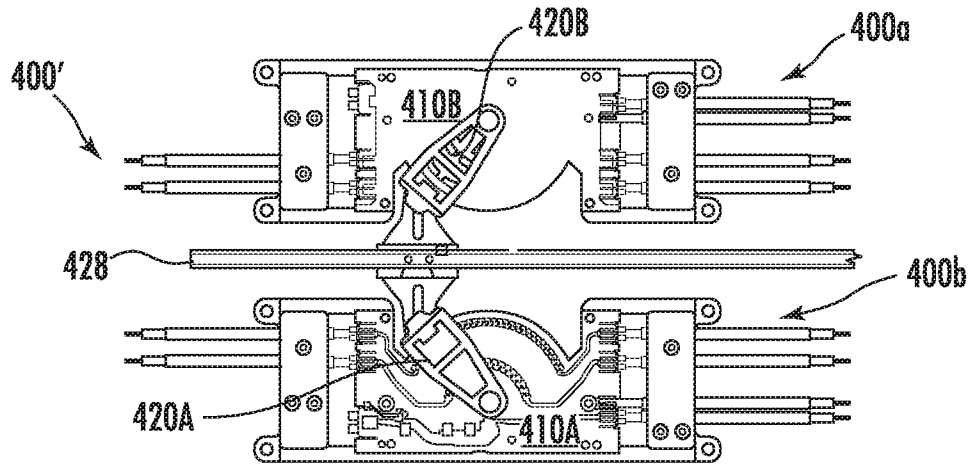

FIG. 29A

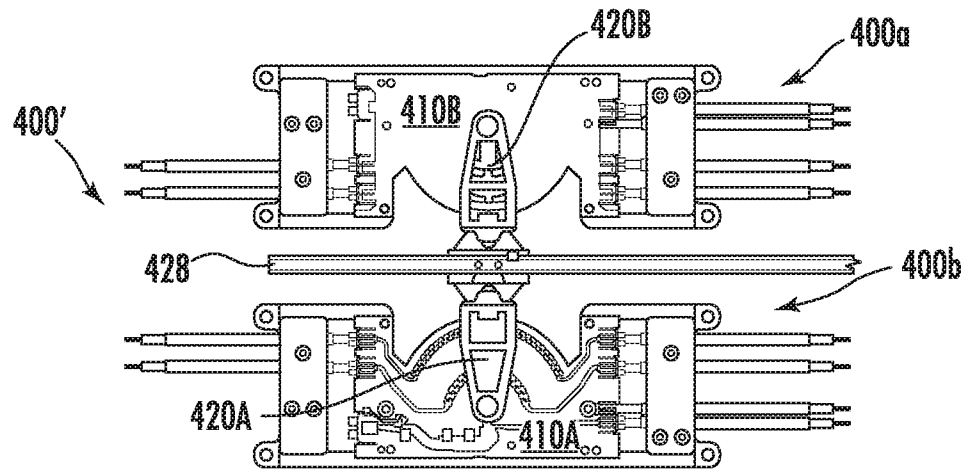

FIG. 29B

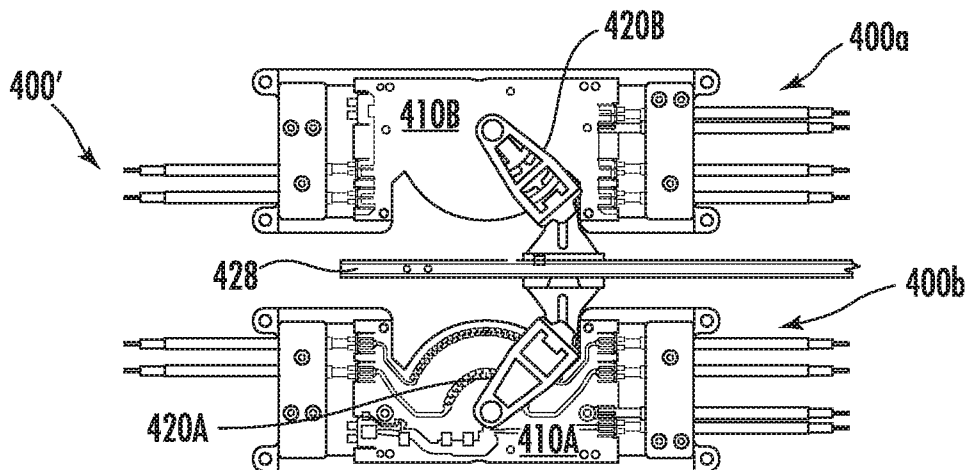

FIG. 29C

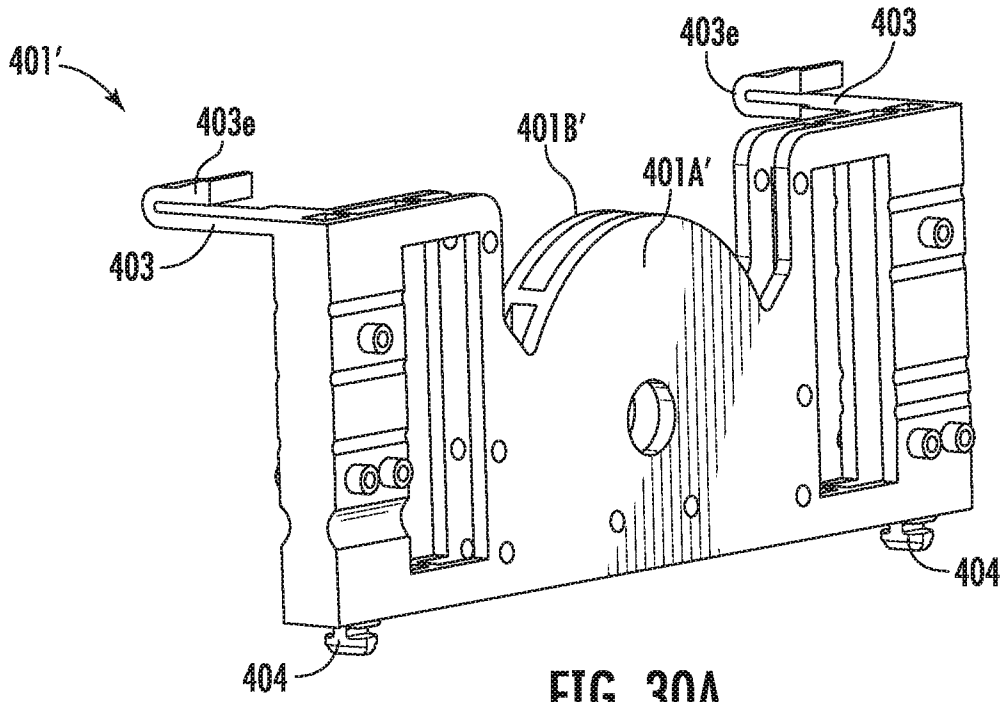

FIG. 30A

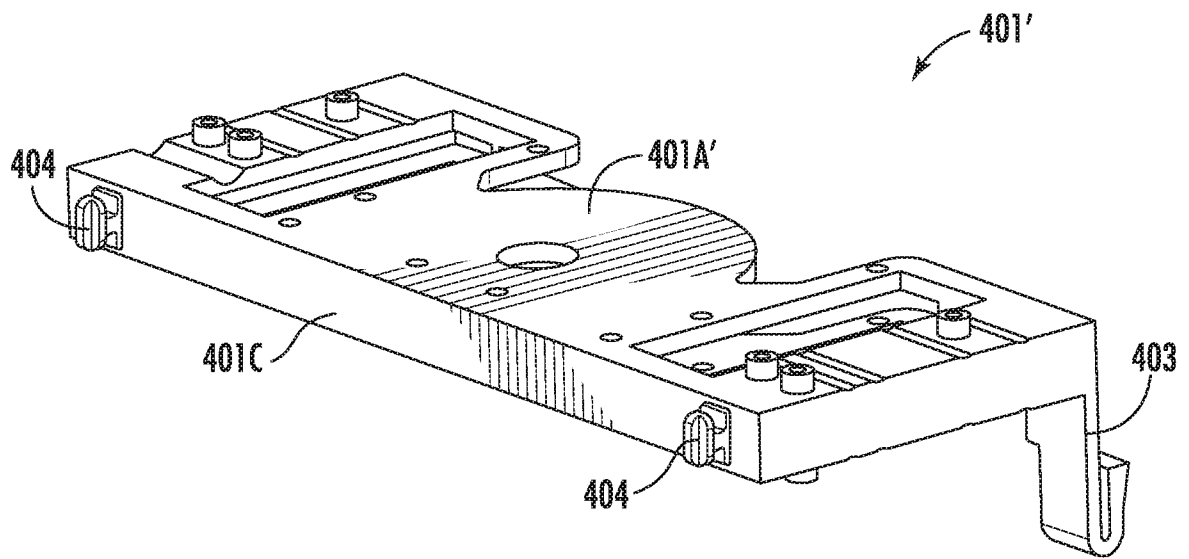

FIG. 30B

42/48

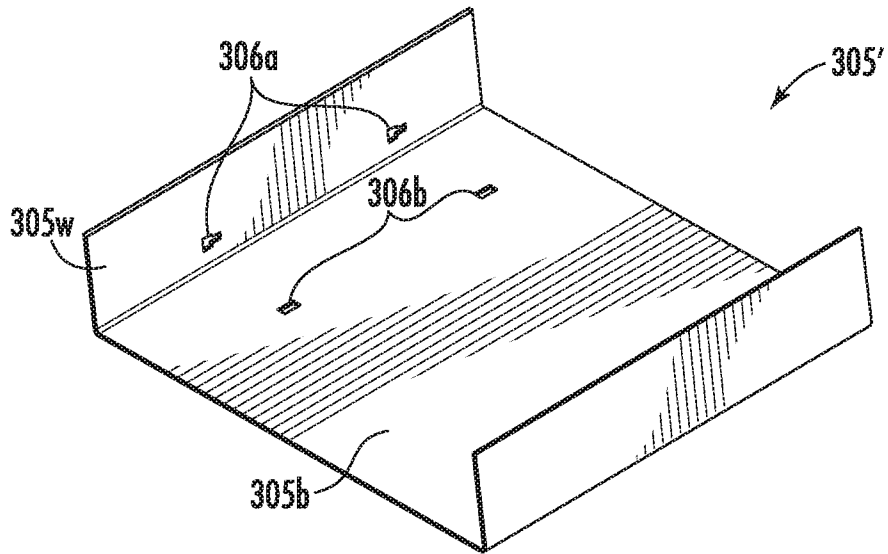

FIG. 31

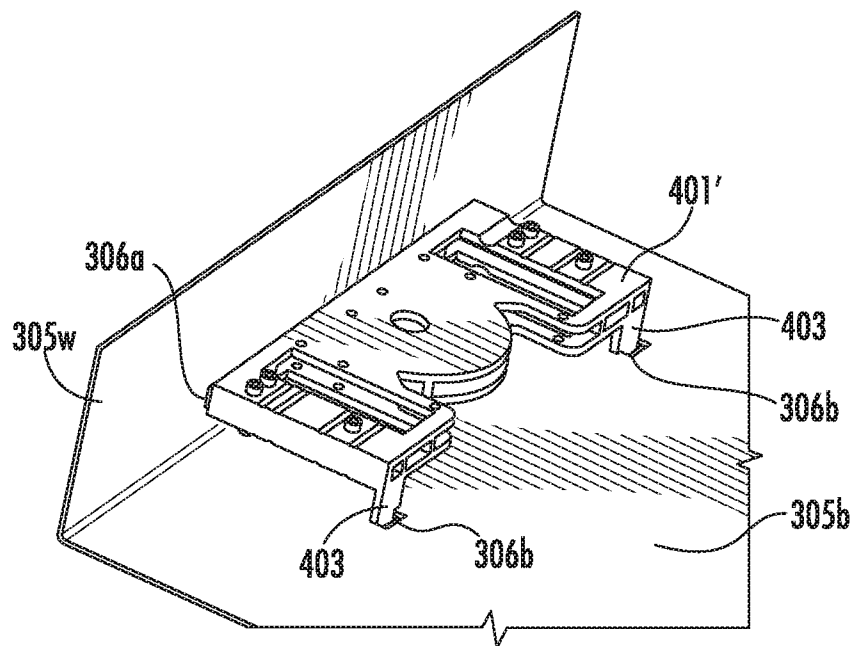

FIG. 32A

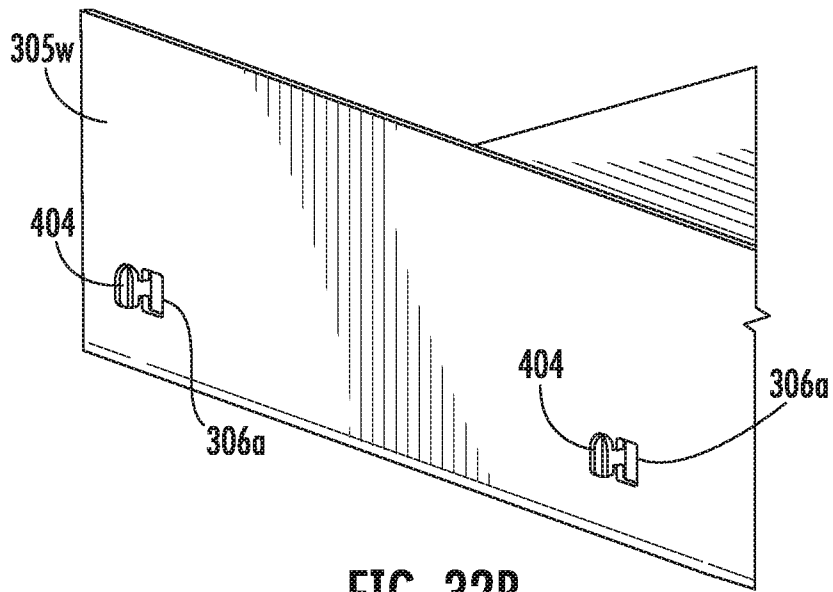

FIG. 32B

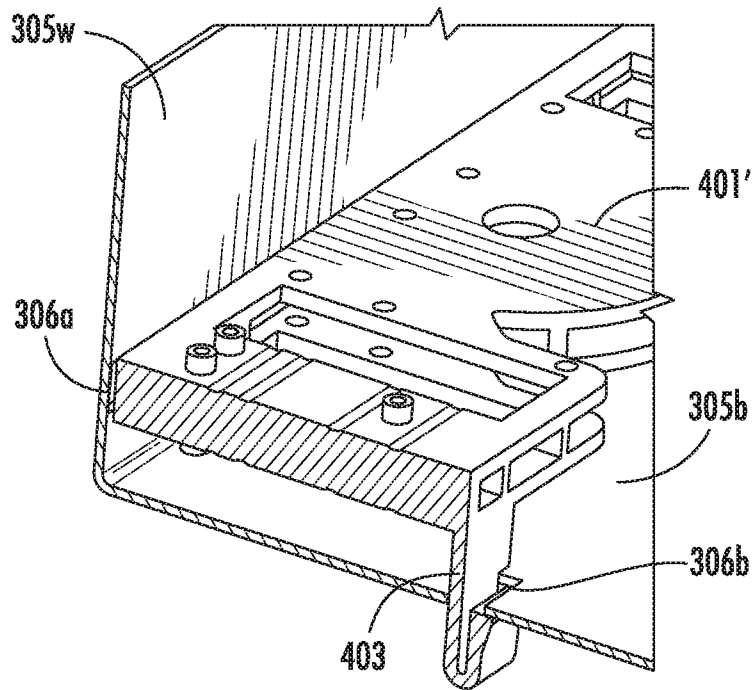

FIG. 32C

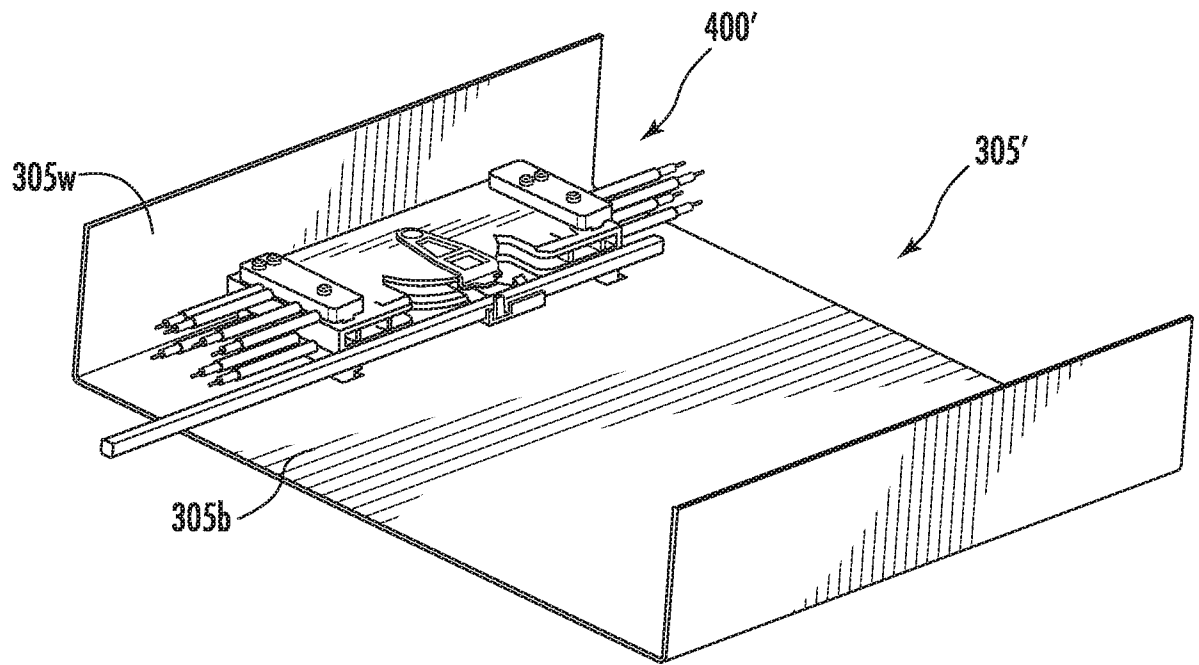

FIG. 33

45/48

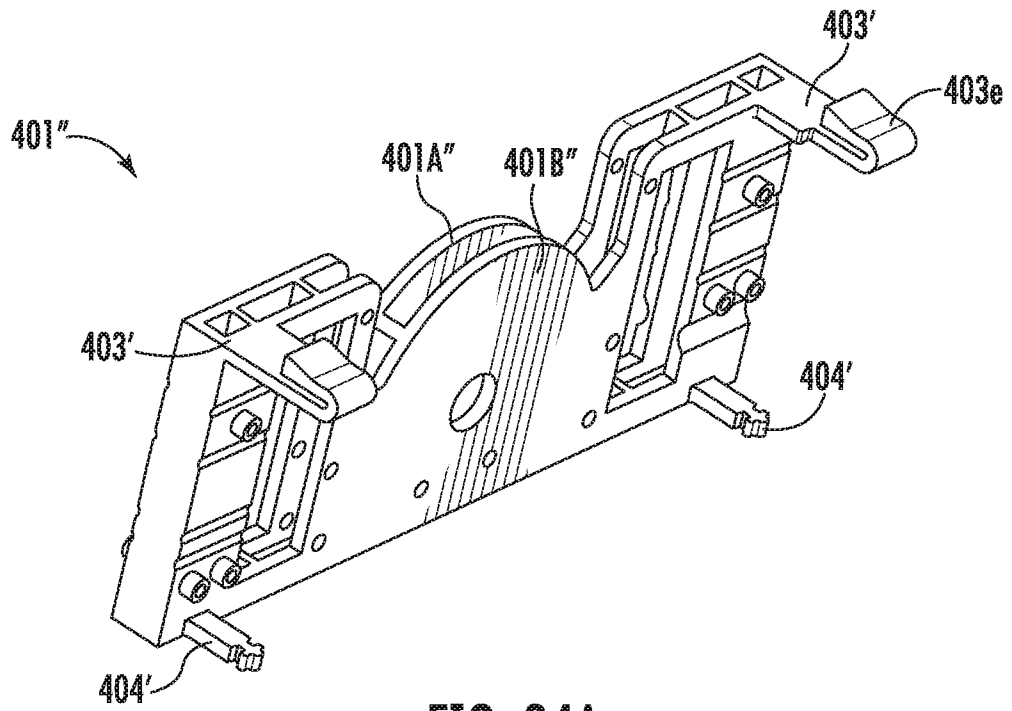

FIG. 34A

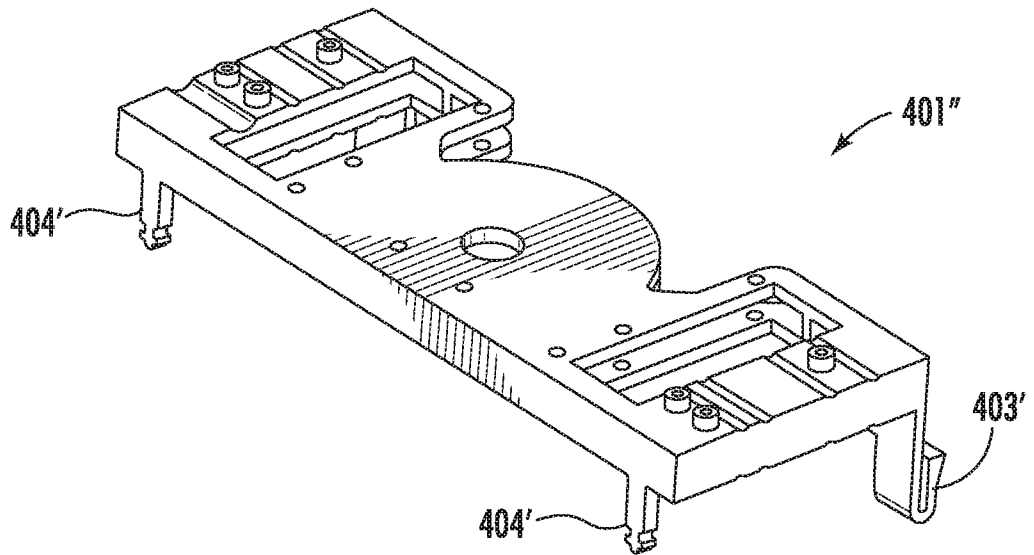

FIG. 34B

46/48

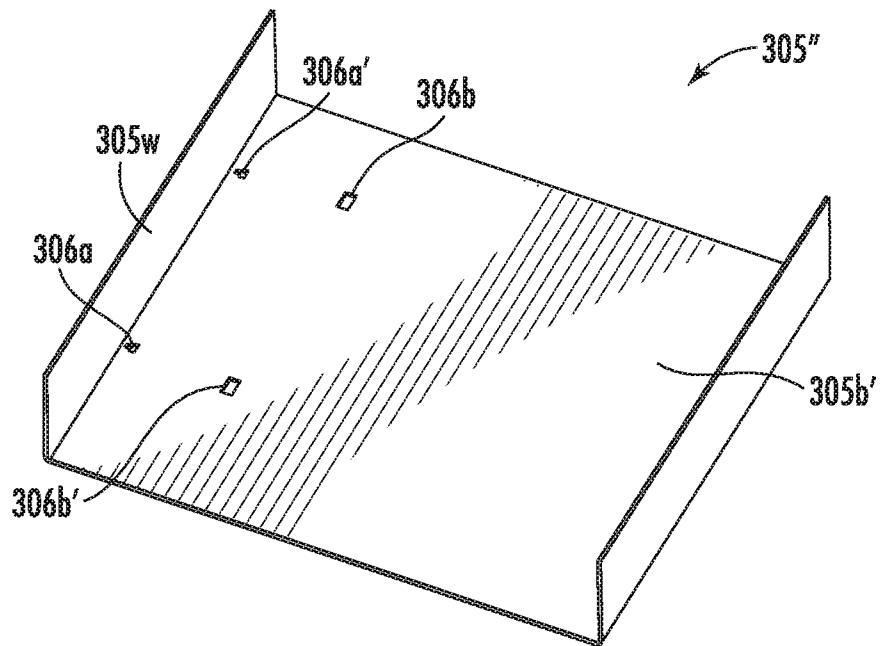

FIG. 35

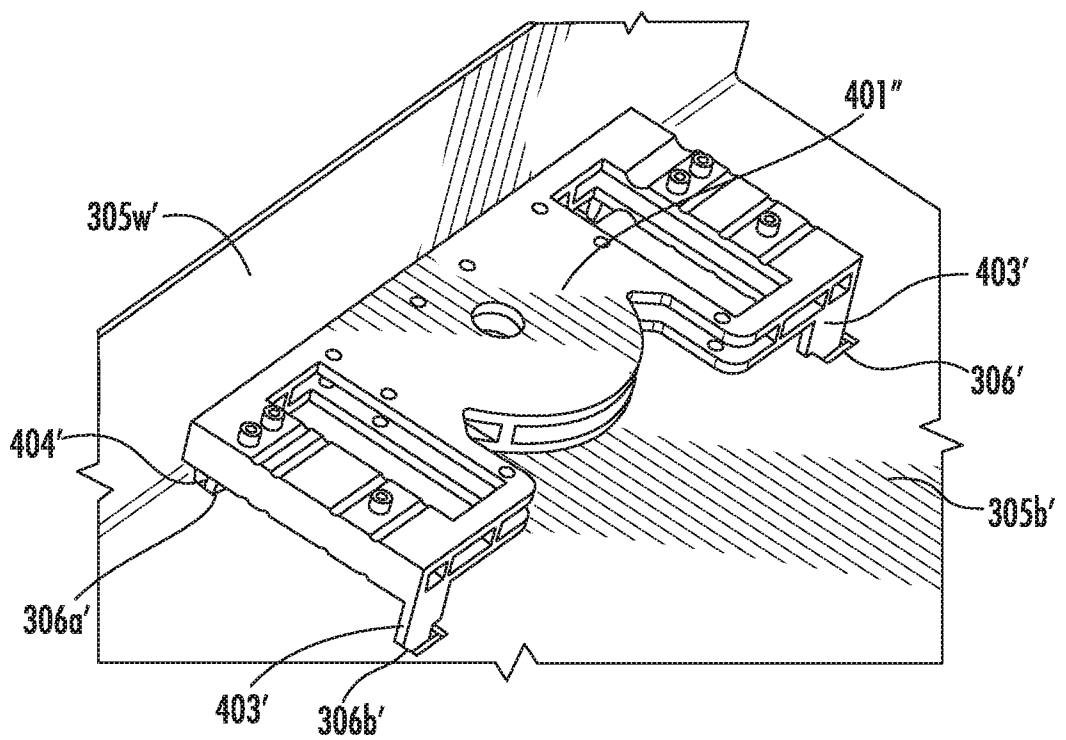

FIG. 36A

47/48

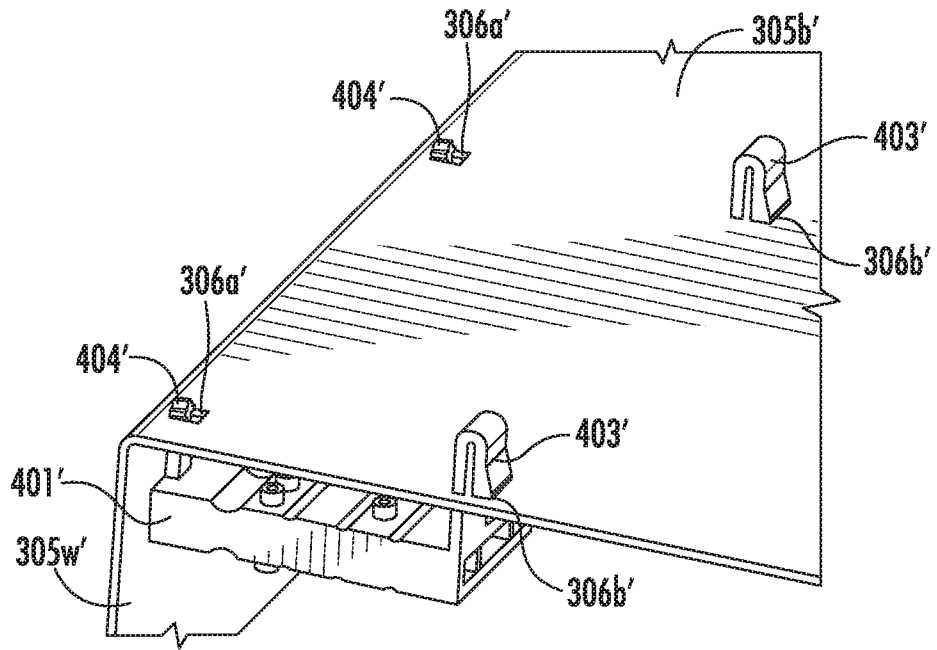

FIG. 36B

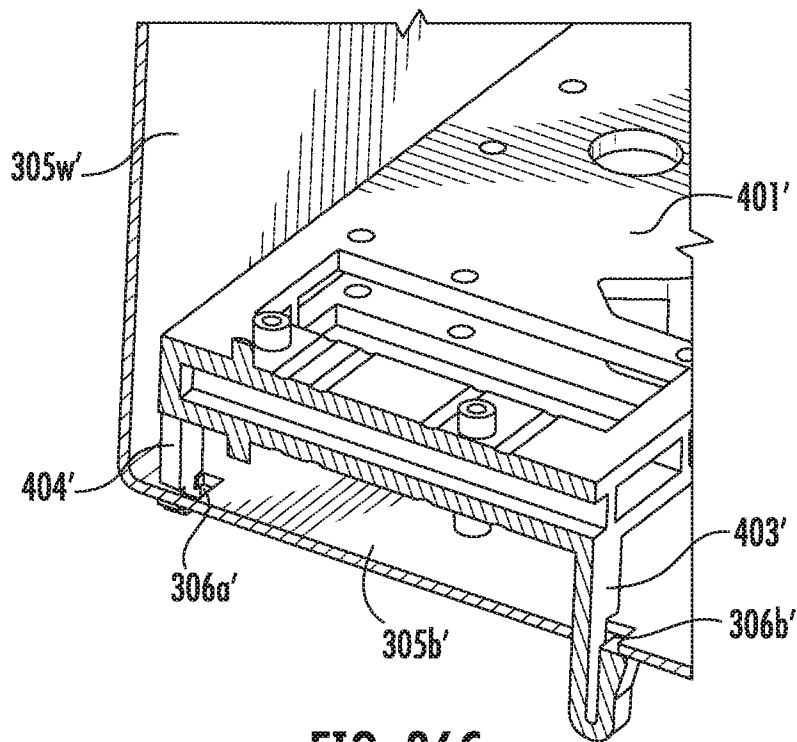

FIG. 36C

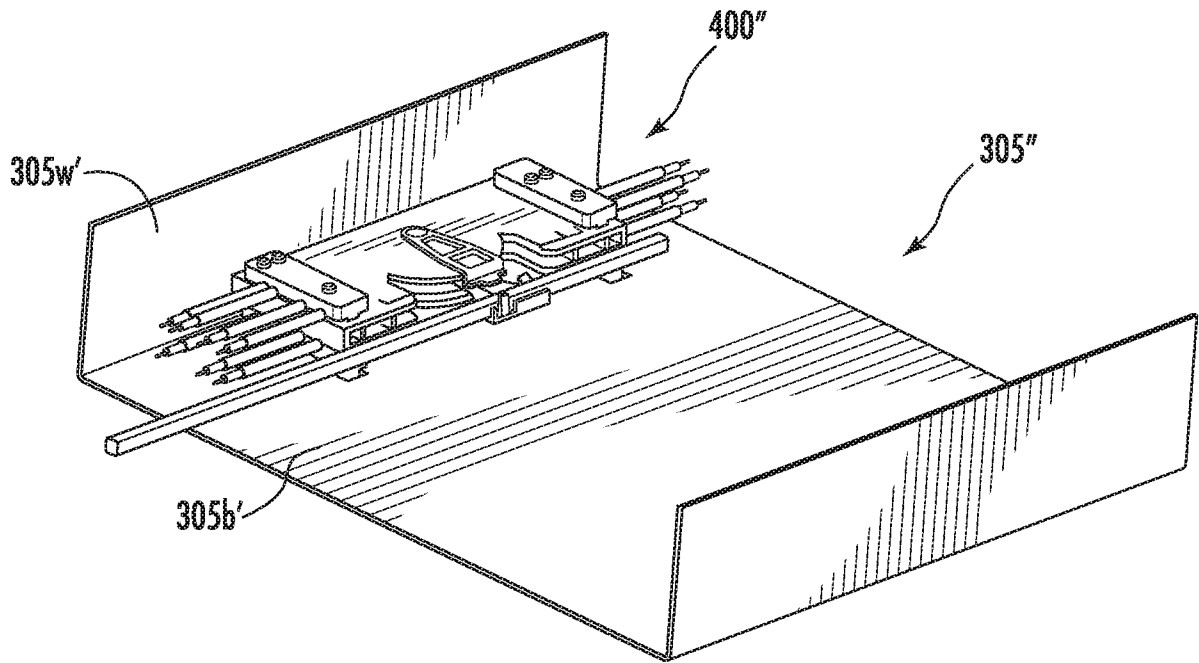

FIG. 37

INTERNATIONAL SEARCH REPORT

International application No.

PCT/US19/51873

A. CLASSIFICATION OF SUBJECT MATTER
 IPC - H01P 1/18; H01Q 3/32; G05K 1/02, 9/00 (2019.01)
 CPC - H01P 1/18; H01Q 3/32; G05K 1/02, 9/00

According to International Patent Classification (IPC) or to both national classification and IPC

B. FIELDS SEARCHED

Minimum documentation searched (classification system followed by classification symbols)
 See Search History document

Documentation searched other than minimum documentation to the extent that such documents are included in the fields searched
 See Search History document

Electronic data base consulted during the international search (name of data base and, where practicable, search terms used)
 See Search History document

C. DOCUMENTS CONSIDERED TO BE RELEVANT

Category*	Citation of document, with indication, where appropriate, of the relevant passages	Relevant to claim No.
X -- Y	US 2009/0189826 A1 (TIMOFEEV, I et al.) 30 July 2009, fig. 4 paragraphs [0021], [0043], [0061]	1 -- 2-3, 9
Y	US 2011/0063049 A1 (BRADLEY, E et al.) 17 March 2011, fig. 1, paragraphs [0056], [0074]	2, 3/2, 9
Y	TW 201406276 A (TDK TIAWAN CORP) 01 February 2014, abstract	3/1-3/2

Further documents are listed in the continuation of Box C. See patent family annex.

* Special categories of cited documents:

"A" document defining the general state of the art which is not considered to be of particular relevance	"T" later document published after the international filing date or priority date and not in conflict with the application but cited to understand the principle or theory underlying the invention
"D" document cited by the applicant in the international application	"X" document of particular relevance; the claimed invention cannot be considered novel or cannot be considered to involve an inventive step when the document is taken alone
"E" earlier application or patent but published on or after the international filing date	"Y" document of particular relevance; the claimed invention cannot be considered to involve an inventive step when the document is combined with one or more other such documents, such combination being obvious to a person skilled in the art
"L" document which may throw doubts on priority claim(s) or which is cited to establish the publication date of another citation or other special reason (as specified)	"&" document member of the same patent family
"O" document referring to an oral disclosure, use, exhibition or other means	
"P" document published prior to the international filing date but later than the priority date claimed	

Date of the actual completion of the international search
 12 November 2019 (12.11.2019)

Date of mailing of the international search report
24 JAN 2020

Name and mailing address of the ISA/US
 Mail Stop PCT, Attn: ISA/US, Commissioner for Patents
 P.O. Box 1450, Alexandria, Virginia 22313-1450
 Facsimile No. 571-273-8300

Authorized officer
 Shane Thomas
 Telephone No. PCT Helpdesk: 571-272-4300

INTERNATIONAL SEARCH REPORT

International application No.

PCT/US19/51873

Box No. II Observations where certain claims were found unsearchable (Continuation of item 2 of first sheet)

This international search report has not been established in respect of certain claims under Article 17(2)(a) for the following reasons:

- 1. Claims Nos.:
because they relate to subject matter not required to be searched by this Authority, namely:

- 2. Claims Nos.:
because they relate to parts of the international application that do not comply with the prescribed requirements to such an extent that no meaningful international search can be carried out, specifically:

- 3. Claims Nos.: 4-8, 10-20, 24-28, 33, 34.2,35-38, 47-48
because they are dependent claims and are not drafted in accordance with the second and third sentences of Rule 6.4(a).

Box No. III Observations where unity of invention is lacking (Continuation of item 3 of first sheet)

This International Searching Authority found multiple inventions in this international application, as follows:

*** Continued in Extra Sheet ***

- 1. As all required additional search fees were timely paid by the applicant, this international search report covers all searchable claims.
- 2. As all searchable claims could be searched without effort justifying additional fees, this Authority did not invite payment of additional fees.
- 3. As only some of the required additional search fees were timely paid by the applicant, this international search report covers only those claims for which fees were paid, specifically claims Nos.:

- 4. No required additional search fees were timely paid by the applicant. Consequently, this international search report is restricted to the invention first mentioned in the claims; it is covered by claims Nos.:
1-3, 9

- Remark on Protest**
- The additional search fees were accompanied by the applicant's protest and, where applicable, the payment of a protest fee.
 - The additional search fees were accompanied by the applicant's protest but the applicable protest fee was not paid within the time limit specified in the invitation.
 - No protest accompanied the payment of additional search fees.

-***-Continued from Box III -***-

This application contains the following inventions or groups of inventions which are not so linked as to form a single general inventive concept under PCT Rule 13.1. In order for all inventions to be examined, the appropriate additional examination fee must be paid.

Group I: Claims 1-3, 9 are directed towards a phase shifter assembly having first and second wiper arms connected to opposing sides of the main circuit board.

Group II: Claims 21-23 and 42-46 are directed towards a base station antenna having first and second main printed circuit boards with respective wiper arms coupled to each.

Group III: Claims 29-34 are directed towards a base station antenna having a plurality of rearwardly extending phase shifter assemblies.

Group IV: Claims 39-41 are directed towards a method of assembling a base station by mounting each phase shifter assembly to a support member.

The inventions listed as Groups I-IV do not relate to a single general inventive concept under PCT Rule 13.1 because, under PCT Rule 13.2, they lack the same or corresponding special technical features for the following reasons:

The special technical features of Group I include at least a phase shifter assembly, comprising: a main printed circuit board comprising opposing first and second primary sides, wherein the main printed circuit board comprises a plurality of radio frequency "RF" transmission paths on the first primary side and a plurality of RF transmission paths on the second primary side; a first wiper arm rotatably coupled to the main printed circuit board and electrically coupled to at least some of the plurality of transmission paths on the first primary side of the main printed circuit board; and a second wiper arm rotatably coupled to the main printed circuit board and electrically coupled to at least some of the plurality of transmission paths on the second primary side of the main printed circuit board, which are not present in Groups II-IV.

The special technical features of Group II include at least a base station antenna, comprising: a plate comprising opposing first and second primary surfaces and a first slot; a phase shifter assembly adapted for mitigating passive intermodulation within a base station antenna, the assembly comprising: a polymeric mounting base having opposing first and second primary sides; base station antenna, comprising: a reflector; and a plurality of phase shifter assemblies, each phase shifter assembly comprising: a polymeric mounting base comprising opposing first and second primary sides; a first main printed circuit board comprising a plurality of radio frequency "RF" transmission paths residing on the first primary surface of the plate; a second main printed circuit board comprising a plurality of RF transmission paths residing on the second primary surface of the plate, aligned with the first main printed circuit board; a first wiper arm rotatably coupled to the first main printed circuit board; and a second wiper arm rotatably coupled to the second main printed circuit board, wherein the first and second wiper arms cooperate with the first slot in the plate and a pivot pin extending through the first and second main printed circuit boards and the plate to be able to rotate in concert relative to the first and second main printed circuit boards to thereby adjust lengths of RF transmission paths on respective first and second main printed circuit boards, which are not present in Groups I & III-IV.

The special technical features of Group III include at least base station antenna, comprising: a plurality of rearwardly extending phase shifter assemblies, wherein each of the phase shifter assemblies are aligned substantially perpendicular to a plane defined by the reflector, which are not present in Groups I-II & IV.

The special technical features of Group IV include at least a method of assembling a base station antenna, the method comprising: providing a plurality of phase shifter assemblies, each phase shifter assembly comprising a first and a second plate arranged back-to-back and extending parallel to each other; mounting each phase shifter assembly to a support member such that the first and second plates are oriented perpendicular to the support member; and integrating the support member comprising the plurality of phase shifter assemblies mounted thereon into the base station antenna, which are not present in Groups I-III.

The common technical features shared by Groups I-IV are a phase shifter assembly comprising: a main printed circuit board; a plurality of radio frequency "RF" transmission paths; a first wiper arm rotatably coupled to a main board; and a second wiper arm rotatably coupled to a main board; and a base station antenna comprising a reflector.

However, these common features are previously disclosed by US 2009/0189826 A1 to TIMOFEEV, I et al. (hereinafter "Timofeev"). Timofeev discloses a phase shifter assembly, comprising (phase shifter, abstract): a main printed circuit board (a PCB having a top and bottom as shown in fig. 4, paragraph [0061]); a plurality of radio frequency "RF" transmission paths; a first wiper arm rotatably coupled to a main board; and a second wiper arm rotatably coupled to a main board (the multi-bladed wiper has two arms (first and second wiper arms) is connected to both the top and bottom of the PCB at the conductive strips which are an outputs to the antennas (plurality of RF transmission paths) as shown in fig 4 and connected to the PCB at a pivot point (rotatably coupled), paragraphs [0021], [0061]); and a base station antenna comprising (base station antenna (paragraph [0086]): a reflector (teeth which cause reflections, claim 23 of Timofeev).

Since the common technical features are previously disclosed by the Timofeev reference, these common features are not special and so Groups I-IV lack unity.