

(19) World Intellectual Property Organization
International Bureau



(43) International Publication Date
11 August 2011 (11.08.2011)

(10) International Publication Number
WO 2011/096005 A1

(51) International Patent Classification:
H02K 15/02 (2006.01)

(21) International Application Number:
PCT/IT2010/000040

(22) International Filing Date:
5 February 2010 (05.02.2010)

(25) Filing Language: Italian

(26) Publication Language: English

(71) Applicant (for all designated States except US):
TRANCERIE EMILIANE S.P.A. [IT/IT]; Strada Manara n. 22, I-43100 Parma (IT).

(72) Inventor; and

(75) Inventor/Applicant (for US only): **FELISA, Pierino** [IT/IT]; c/o TRANCERIE EMILIANE S.P.A., Strada Manara n. 22, I-43100 Parma (IT).

(74) Agent: **GUARESCHI, Antonella**; c/o ING. DAL-
LAGLIO S.R.L., Via Mazzini n. 2, I-43121 Parma (IT).

(81) Designated States (unless otherwise indicated, for every kind of national protection available): AE, AG, AL, AM,

AO, AT, AU, AZ, BA, BB, BG, BH, BR, BW, BY, BZ, CA, CH, CL, CN, CO, CR, CU, CZ, DE, DK, DM, DO, DZ, EC, EE, EG, ES, FI, GB, GD, GE, GH, GM, GT, HN, HR, HU, ID, IL, IN, IS, JP, KE, KG, KM, KN, KP, KR, KZ, LA, LC, LK, LR, LS, LT, LU, LY, MA, MD, ME, MG, MK, MN, MW, MX, MY, MZ, NA, NG, NI, NO, NZ, OM, PE, PG, PH, PL, PT, RO, RS, RU, SC, SD, SE, SG, SK, SL, SM, ST, SV, SY, TH, TJ, TM, TN, TR, TT, TZ, UA, UG, US, UZ, VC, VN, ZA, ZM, ZW.

(84) Designated States (unless otherwise indicated, for every kind of regional protection available): ARIPO (BW, GH, GM, KE, LS, MW, MZ, NA, SD, SL, SZ, TZ, UG, ZM, ZW), Eurasian (AM, AZ, BY, KG, KZ, MD, RU, TJ, TM), European (AT, BE, BG, CH, CY, CZ, DE, DK, EE, ES, FI, FR, GB, GR, HR, HU, IE, IS, IT, LT, LU, LV, MC, MK, MT, NL, NO, PL, PT, RO, SE, SI, SK, SM, TR), OAPI (BF, BJ, CF, CG, CI, CM, GA, GN, GQ, GW, ML, MR, NE, SN, TD, TG).

Declarations under Rule 4.17:

- as to applicant's entitlement to apply for and be granted a patent (Rule 4.17(ii))
- of inventorship (Rule 4.17(iv))

[Continued on next page]

(54) Title: PROCESS FOR MAKING A STATOR OR ROTOR LAMINATION PACK FOR A LARGE ELECTRIC ROTATING MACHINE

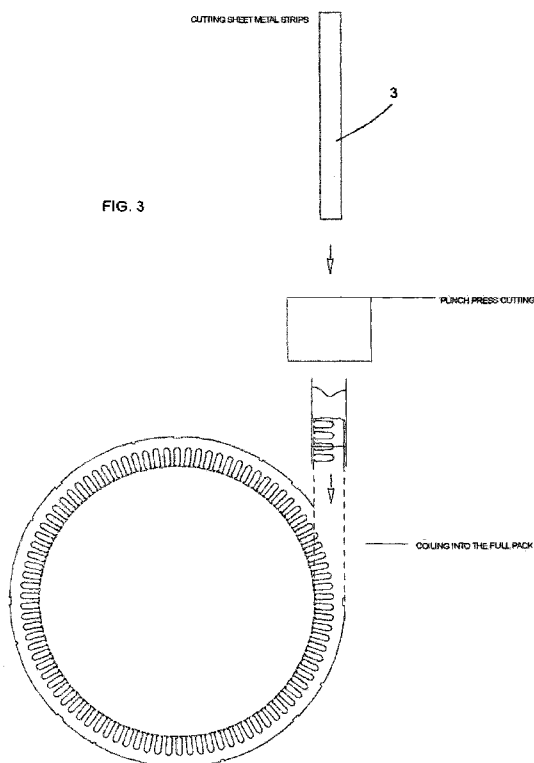

(57) Abstract: The invention finds application in the field of electric rotating machines and namely relates to a process for making a stator or rotor lamination pack for an electric rotating machine. The process includes punching of a rectilinear sheet metal strip and curving of said strip at a later time. The rectilinear strip may be punched continuously or alternately.

WO 2011/096005 A1

Published:

— *with international search report (Art. 21(3))*

TITLE: PROCESS FOR MAKING A STATOR OR ROTOR LAMINATION
PACK FOR A LARGE ELECTRIC ROTATING MACHINE

SPECIFICATION

The present invention relates to a process for
5 forming a lamination pack for stators or rotors of
electric machines such as alternators, motors,
generators and electric rotating machines in general,
particularly having large sizes.

In large-diameter (> 300 mm) rotors and stators,
10 the lamination pack is currently formed by punching
circular sectors from the sheet metal strip or coil and
later welding together the sectors.

According to another prior art method, the whole
annulus is punched and the portion inside the annulus
15 is recovered to obtain smaller-diameter laminations.

These methods involve high manufacturing costs for
the lamination packs due to a number of reasons,
including:

creation of unrecoverable off-cuts (only
20 recoverable as scrap) of high cost material, with more
or less performing sheet metal being increasingly
required;

high pack formation costs, due to the welding
required for joining the sectors even with small or
25 medium diameters;

if the lamination packs are required to have
inclined slots, they cannot be automatically formed
during the punching step;

a special circular die is required for lamination
30 die, which involves huge investments both for the
number and the size of the dies.

The main object of the present invention is to
limit the off-cuts to the slot material, which may be

achieved by linear punching of a rectilinear sheet metal strip.

A further object is to dramatically reduce the investments on plants and dies associated with varying diameters of stators and rotors.

Yet another object is to reduce the installed power for the equipment and thus achieve power savings with identical throughputs.

These objects and advantages are achieved by the process for making a stator or rotor lamination pack for a large-diameter electric machine according to this invention, which is characterized as defined in the annexed claims.

These and other features will be more apparent upon reading the following description of the process, with reference to the steps as schematically shown in the accompanying drawings, in which:

Figures 1 and 2 show a punching step according to the prior art;

Figures 3, 3a, 3b, 3c show the punching steps according to the present invention.

Referring now to Figure 1, it will be noted that the cutting of a sector 1 requires the whole hatched area 2 to be discarded and be only recovered as scrap.

Even worse, if the whole lamination is punched, then the internal area may be possibly recovered to obtain smaller diameter laminations, but this involves high manufacturing costs.

Referring to Figure 3, according to the present invention, the punching operation is performed rectilinearly on the continuous strip 3, which has already been cut to a height corresponding to the difference between the inside and outside diameters of

the stator pack.

Therefore, the slot material is the only scrap that is created.

Then, the rectilinear strip is continuously
5 curved, to obtain circular laminations connected together into a pack of desired height.

Welds made along multiple generators of the pack will adequately maintain the laminations in contact with each other and ensure bonding therebetween.

10 The circle may be divided into sections in case of large diameters.

The number of sections will be defined by the transportation potential, the weight of the section being handled and by customer requirements,
15 particularly in view of reducing assembly times and costs.

In order to prevent folds or corrugations from forming during continuous bending of the rectilinear lamination, V-shaped cuts 4 have been formed.

20 These cuts 4 are formed during slot punching and are evenly arranged along the band opposite to that in which the slots have been formed.

With the process as described above, a single punch press may be used for all diameters, and the slot
25 dies will only need to be replaced.

The installed power for the machines that stamp the whole sheet metal sector is considerably higher than that required by a machine that stamps a rectilinear sheet, hence the above process affords
30 considerable savings in terms of investments on equipment and dies and power.

The above process provides sections or sectors of laminations that can be transported with no limit as to

the final diameter of the pack, which provides all the above advantages, i.e.:

reduced off-cuts;

lower investments on equipment and dies;

- 5 lower installed power, and lower operating costs of plants.

CLAIMS

1. A process for making a stator or rotor lamination pack for a large electric rotating machine, characterized in that it includes:
- 5 - continuous rectilinear punching of a sheet metal strip as high as the difference between the inside and outside diameters of the stator or rotor pack;
- continuous curving of the strip to obtain a plurality of helically overlapping laminations to the
10 desired height of the lamination pack.
2. A process as claimed in claim 1, characterized in that continuous curving includes the formation of the pack with inclined slots.
3. A process as claimed in claim 1,
15 characterized in that, in the case of large-diameter lamination packs, after linear punching and curving, packs are cut into strip sections or segments for transportation.
4. A process as claimed in claim 1,
20 characterized in that, cuts (4) are formed during linear punching which are evenly arranged along the band opposite to that in which the slots have been formed.

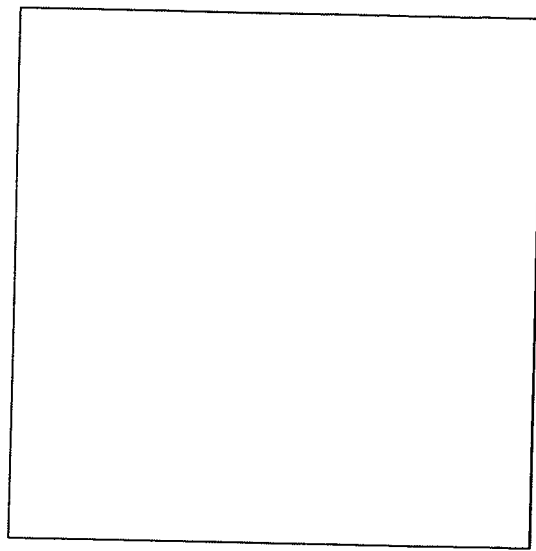

FIG. 1

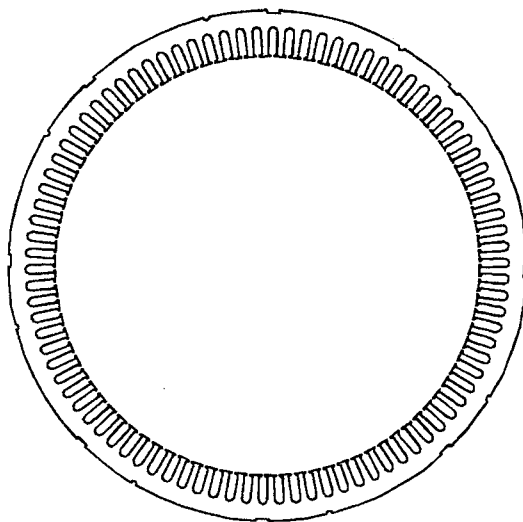
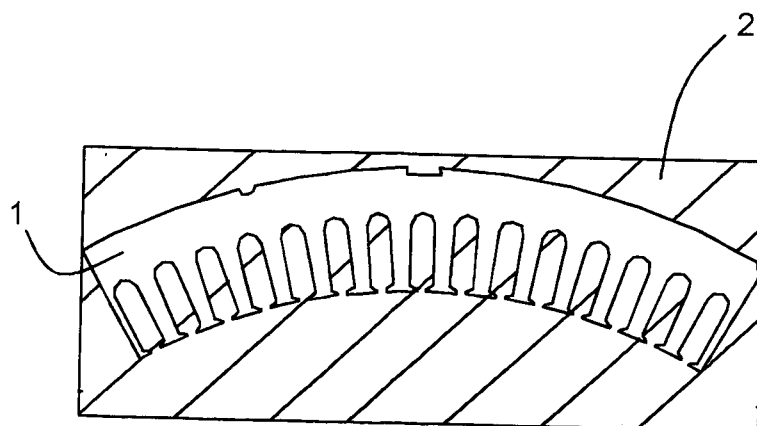

FIG. 2



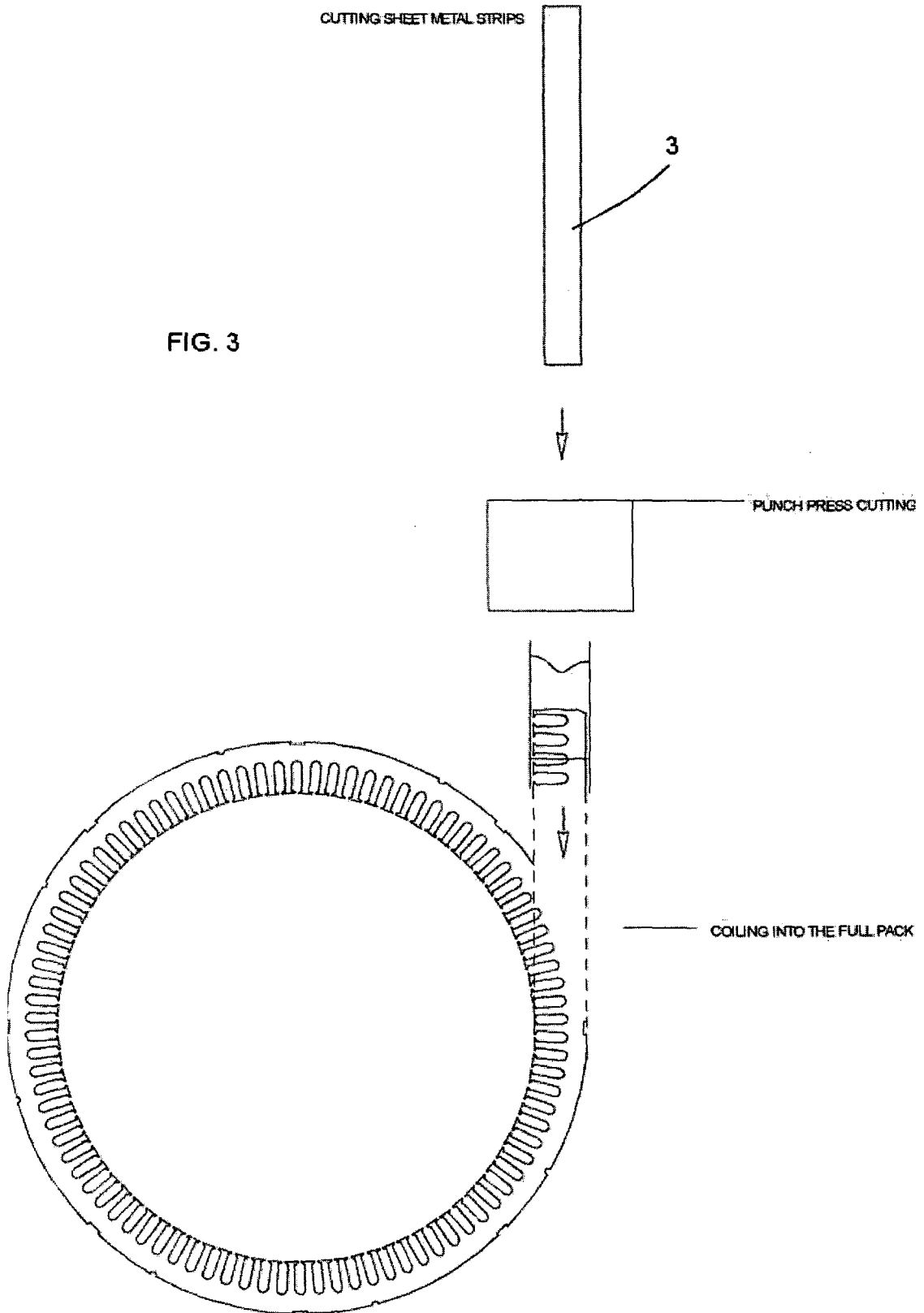

FIG. 3A

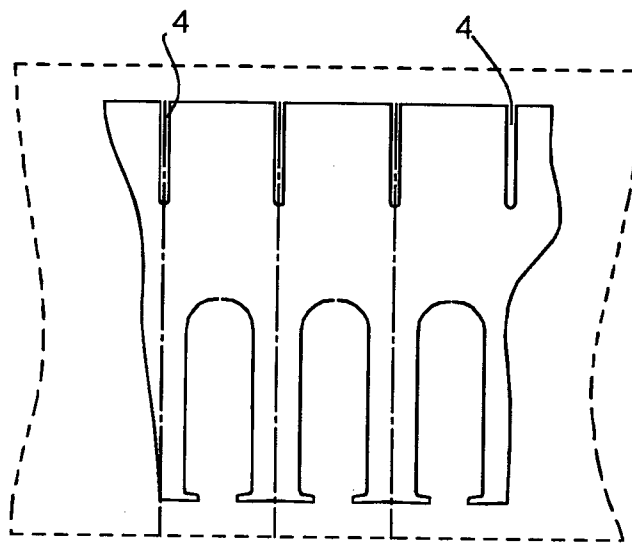

FIG. 3B

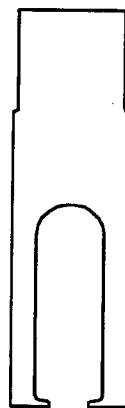
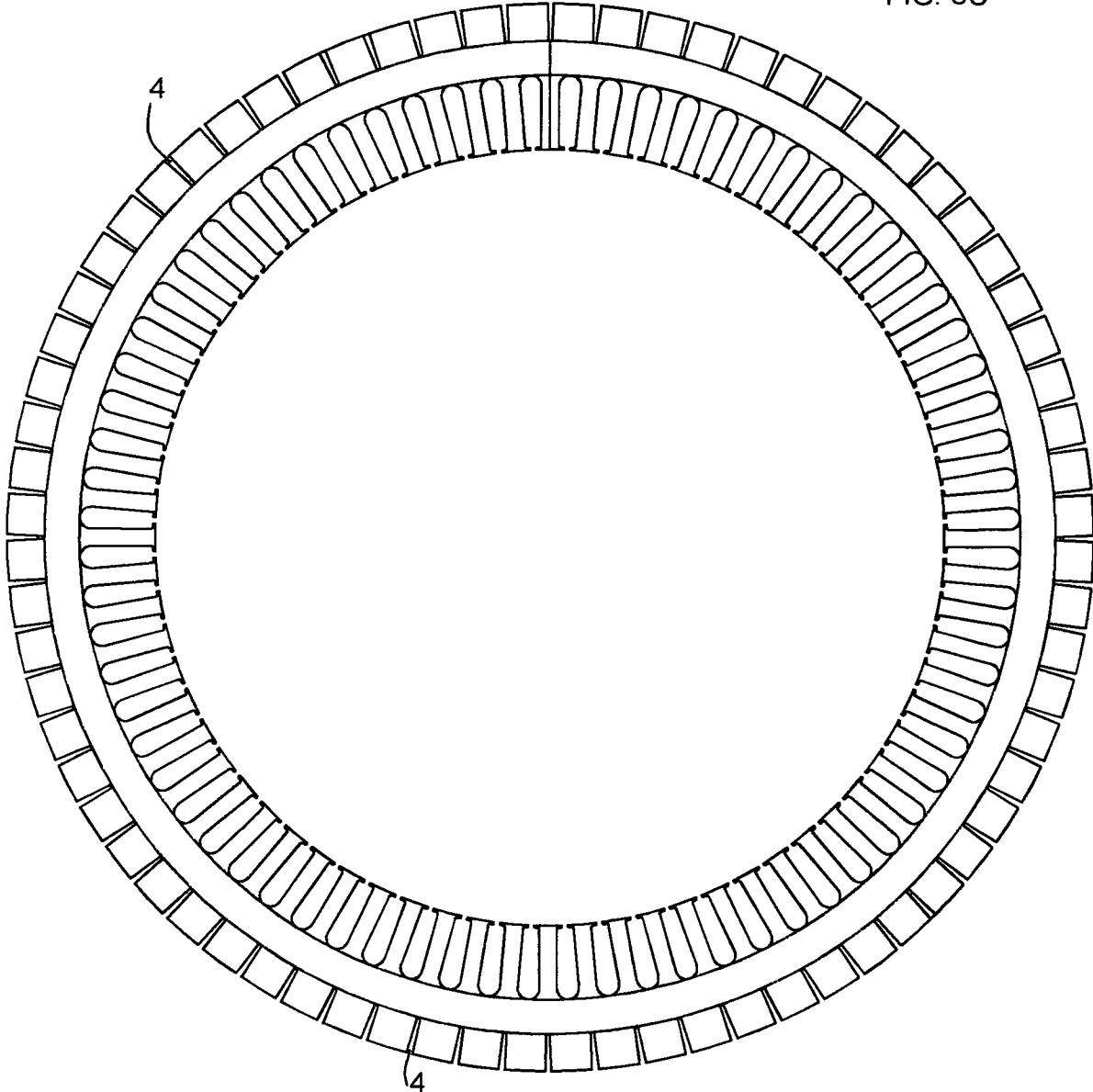

FIG. 3C



INTERNATIONAL SEARCH REPORT

International application No
PCT/IT2010/000040

A. CLASSIFICATION OF SUBJECT MATTER
INV. H02K15/02
ADD.
According to International Patent Classification (IPC) or to both national classification and IPC

B. FIELDS SEARCHED
Minimum documentation searched (classification system followed by classification symbols)
H02K

Documentation searched other than minimum documentation to the extent that such documents are included in the fields searched

Electronic data base consulted during the international search (name of data base and, where practical, search terms used)
EPO-Internal

C. DOCUMENTS CONSIDERED TO BE RELEVANT

Category*	Citation of document, with indication, where appropriate, of the relevant passages	Relevant to claim No.
X	US 4 403 489 A (MUNSTERMAN RONALD S [US] ET AL) 13 September 1983 (1983-09-13) figures 2,3 -----	1,3
X	US 4 395 815 A (STANLEY LOUIS [AU] ET AL) 2 August 1983 (1983-08-02) figure 2 -----	1
X	EP 1 517 427 A2 (HITACHI LTD [JP]; HITACHI CAR ENG CO LTD [JP]) 23 March 2005 (2005-03-23) figure 2 -----	1,4
X	JP 55 141958 A (MATSUSHITA ELECTRIC IND CO LTD) 6 November 1980 (1980-11-06) abstract figures 1,2 ----- -/--	1,2

Further documents are listed in the continuation of Box C.

See patent family annex.

* Special categories of cited documents :

- "A" document defining the general state of the art which is not considered to be of particular relevance
- "E" earlier document but published on or after the international filing date
- "L" document which may throw doubts on priority claim(s) or which is cited to establish the publication date of another citation or other special reason (as specified)
- "O" document referring to an oral disclosure, use, exhibition or other means
- "P" document published prior to the international filing date but later than the priority date claimed

- "T" later document published after the international filing date or priority date and not in conflict with the application but cited to understand the principle or theory underlying the invention
- "X" document of particular relevance; the claimed invention cannot be considered novel or cannot be considered to involve an inventive step when the document is taken alone
- "Y" document of particular relevance; the claimed invention cannot be considered to involve an inventive step when the document is combined with one or more other such documents, such combination being obvious to a person skilled in the art.
- "&" document member of the same patent family

Date of the actual completion of the international search 11 April 2011	Date of mailing of the international search report 19/04/2011
Name and mailing address of the ISA/ European Patent Office, P.B. 5818 Patentlaan 2 NL - 2280 HV Rijswijk Tel. (+31-70) 340-2040, Fax: (+31-70) 340-3016	Authorized officer Le Chenadec, Hervé

INTERNATIONAL SEARCH REPORT

International application No
PCT/IT2010/000040

C(Continuation). DOCUMENTS CONSIDERED TO BE RELEVANT		
Category*	Citation of document, with indication, where appropriate, of the relevant passages	Relevant to claim No.
X	JP 60 016159 A (MITSUBISHI ELECTRIC CORP) 26 January 1985 (1985-01-26) abstract figure 4	1

X	US 6 147 431 A (ASAO YOSHIHITO [JP] ET AL) 14 November 2000 (2000-11-14) figure 2	1

INTERNATIONAL SEARCH REPORT

Information on patent family members

International application No PCT/IT2010/000040

Patent document cited in search report	Publication date	Publication date	Patent family member(s)	Publication date
US 4403489	A	13-09-1983	NONE	

US 4395815	A	02-08-1983	NONE	

EP 1517427	A2	23-03-2005	CN 1599197 A	23-03-2005
			CN 101295902 A	29-10-2008
			JP 3894913 B2	22-03-2007
			JP 2005094951 A	07-04-2005
			US 2005061046 A1	24-03-2005
			US 2008072415 A1	27-03-2008

JP 55141958	A	06-11-1980	JP 1484812 C	14-03-1989
			JP 63026618 B	31-05-1988

JP 60016159	A	26-01-1985	NONE	

US 6147431	A	14-11-2000	JP 3359863 B2	24-12-2002
			JP 11299136 A	29-10-1999
