

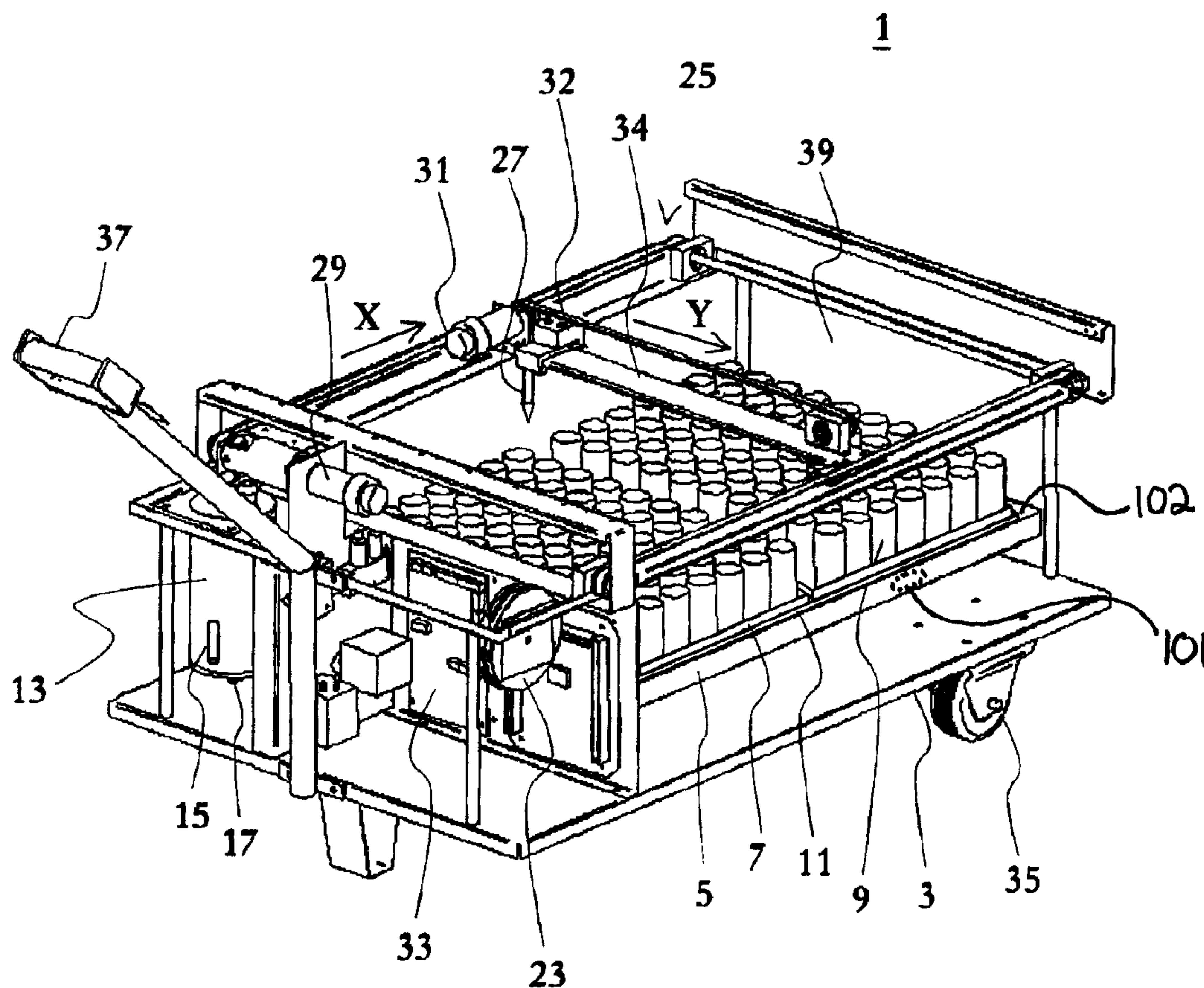

(86) Date de dépôt PCT/PCT Filing Date: 2001/03/28  
 (87) Date publication PCT/PCT Publication Date: 2001/10/11  
 (45) Date de délivrance/Issue Date: 2009/09/29  
 (85) Entrée phase nationale/National Entry: 2002/10/02  
 (86) N° demande PCT/PCT Application No.: SE 2001/000676  
 (87) N° publication PCT/PCT Publication No.: 2001/074149  
 (30) Priorité/Priority: 2000/04/03 (SE0001196-5)

(51) Cl.Int./Int.Cl. *A01J 5/007* (2006.01),  
*A01J 5/04* (2006.01), *G01N 33/04* (2006.01),  
*G01N 35/10* (2006.01)  
 (72) Inventeurs/Inventors:  
 GUDMUNDSSON, MATS, SE;  
 MELLBERG, STEN, SE  
 (73) Propriétaire/Owner:  
 DELAVAL HOLDING AB, SE  
 (74) Agent: BORDEN LADNER GERVAIS LLP

(54) Titre : APPAREIL ET PROCEDE DE PRELEVEMENT DE LAIT  
 (54) Title: MILK SAMPLING APPARATUS AND METHOD



(57) Abrégé/Abstract:

The present invention refers to a milk sampling apparatus and method for use with an automated milking system. The apparatus comprises a cassette (7) wherein milk sample collecting elements (9) are placed, and at least one filling member (27) capable of

(57) **Abrégé(suite)/Abstract(continued):**

being placed above a selected one of said milk sample collecting elements (9) by means of a positioning system, and capable of bringing a milk sample, representatively taken from milk yielded during the milking of an animal by means of said automated milking system, into said selected one of said milk sample collecting elements (9). The positioning system comprises an arm (34) extending in a first dimension (Y) in a plane (XY) above said milk sample collecting elements (9) and being movable in a second direction (X) in said plane (XY), said first (Y) and second (X) directions being orthogonal; a runner (32) holding said filling member (27) and being movable along said arm (34); and first (29) and a second (31) drive means, wherein said first drive means (29) is effective to move said arm (34) and said second drive means (31) is effective to move said runner (32) such that said filling member (27) is positioned above said selected one of said milk sample collecting elements (9).

## (12) INTERNATIONAL APPLICATION PUBLISHED UNDER THE PATENT COOPERATION TREATY (PCT)

(19) World Intellectual Property Organization  
International Bureau



(43) International Publication Date  
11 October 2001 (11.10.2001)

PCT

(10) International Publication Number  
**WO 01/74149 A1**

- (51) International Patent Classification<sup>7</sup>: **A01J 5/04**, G01N 1/10 // A01J 7/00
- (21) International Application Number: PCT/SE01/00676
- (22) International Filing Date: 28 March 2001 (28.03.2001)
- (25) Filing Language: English
- (26) Publication Language: English
- (30) Priority Data:  
0001196-5 3 April 2000 (03.04.2000) SE
- (71) Applicant (for all designated States except US):  
**DELAVAL HOLDING AB** [SE/SE]; Box 39, S-147 21 Tumba (SE).
- (72) Inventors; and  
(75) Inventors/Applicants (for US only): **GUDMUNDSSON, Mats** [SE/SE]; Kringelvägen 5B, S-151 33 Södertälje (SE).  
**MELLBERG, Sten** [SE/SE]; Gyllenborgsgatan 15, S-112 43 Stockholm (SE).
- (74) Agents: **FRITZON, Rolf** et al.; Kransell & Wennborg AB, Box 27834, S-115 93 Stockholm (SE).
- (81) Designated States (*national*): AE, AG, AL, AM, AT, AT (utility model), AU, AZ, BA, BB, BG, BR, BY, BZ, CA, CH, CN, CO, CR, CU, CZ, CZ (utility model), DE, DE (utility model), DK, DK (utility model), DM, DZ, EE, EE (utility model), ES, FI, FI (utility model), GB, GD, GE, GH, GM, HR, HU, ID, IL, IN, IS, JP, KE, KG, KP, KR, KZ, LC, LK, LR, LS, LT, LU, LV, MA, MD, MG, MK, MN, MW, MX, MZ, NO, NZ, PL, PT, RO, RU, SD, SE, SG, SI, SK, SK (utility model), SL, TJ, TM, TR, TT, TZ, UA, UG, US, UZ, VN, YU, ZA, ZW.
- (84) Designated States (*regional*): ARIPO patent (GH, GM, KE, LS, MW, MZ, SD, SL, SZ, TZ, UG, ZW), Eurasian patent (AM, AZ, BY, KG, KZ, MD, RU, TJ, TM), European patent (AT, BE, CH, CY, DE, DK, ES, FI, FR, GB, GR, IE, IT, LU, MC, NL, PT, SE, TR), OAPI patent (BF, BJ, CF, CG, CI, CM, GA, GN, GW, ML, MR, NE, SN, TD, TG).
- Published:**  
— with international search report
- For two-letter codes and other abbreviations, refer to the "Guidance Notes on Codes and Abbreviations" appearing at the beginning of each regular issue of the PCT Gazette.

(54) Title: MILK SAMPLING APPARATUS AND METHOD

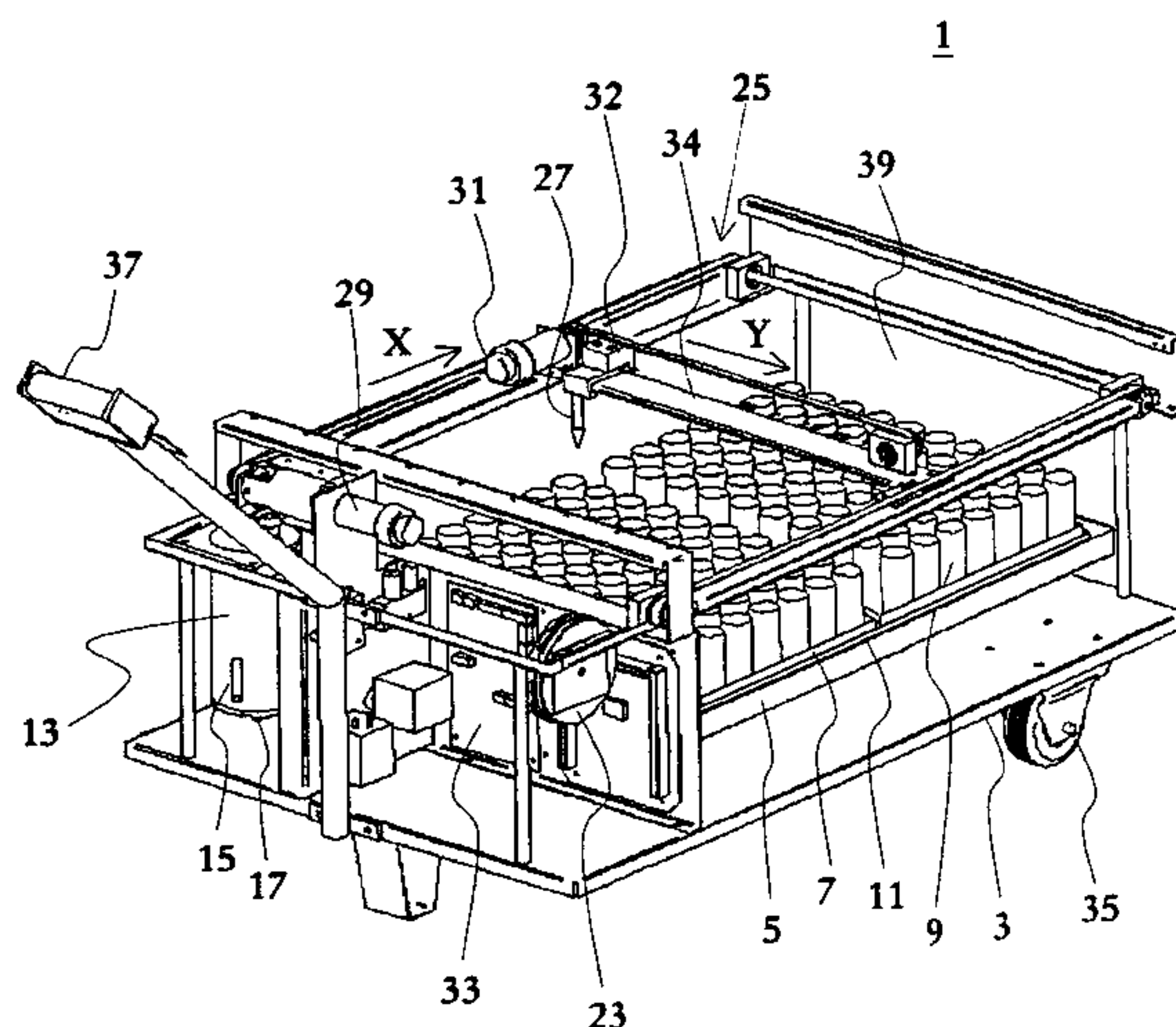

(57) Abstract: The present invention refers to a milk sampling apparatus and method for use with an automated milking system. The apparatus comprises a cassette (7) wherein milk sample collecting elements (9) are placed, and at least one filling member (27) capable of being placed above a selected one of said milk sample collecting elements (9) by means of a positioning system, and capable of bringing a milk sample, representatively taken from milk yielded during the milking of an animal by means of said automated milking system, into said selected one of said milk sample collecting elements (9). The positioning system comprises an arm (34) extending in a first dimension (Y) in a plane (XY) above said milk sample collecting elements (9) and being movable in a second direction (X) in said plane (XY), said first (Y) and second (X) directions being orthogonal; a runner (32) holding said filling member (27) and being movable along said arm (34); and first (29) and a second (31) drive means, wherein said first drive means (29) is effective to move said arm (34) and said second drive means (31) is effective to move said runner (32) such that said filling member (27) is positioned above said selected one of said milk sample collecting elements (9).

WO 01/74149 A1

**MILK SAMPLING APPARATUS AND METHOD****TECHNICAL FIELD OF THE INVENTION**

The present invention generally relates to dairy farm machine milking and to milk sampling related thereto.

5 Particularly, the invention relates to a milk sampling apparatus for use with an automated milking system and to a method for sampling of milk from said automated milking system.

**DESCRIPTION OF RELATED ART AND BACKGROUND OF THE INVENTION**

10 When milking an animal by using an automated milking system, the milk is drawn from the teats of the animal by means of teat cups connected to vacuum. The milk is drawn through a milk tube and into a flow meter wherein the amount of milk is measured. The milk is further transported to a storing tank or similar wherein it is stored together with milk from other animals while waiting  
15 for a milk lorry to collect it.

On regular time basis, e.g. once a month, a sample of the milk from each animal is taken, which sample is typically sent to a laboratory for analysis, in which various parameters such as contents of fat, protein, cell, and urea are examined. It is  
20 expensive to implement the analysis at the milk sampling device and further, the laboratory equipment necessary is space demanding, thus samples are typically taken and sent to a laboratory. Possibly, some kind of simpler measurements could be introduced at the milk sampling device.

25 The milk sampling is typically performed in connection with milking of the animals by employing a milk sampling device provided with a fixed or removable cassette wherein milk test tubes can be placed, and with a filling member connected to the milking system and capable of filling the respective tubes with  
30 milk from the respective animals. When all the tubes are filled

they are removed from the milk sampling device, either manually one by one, or by means of removing the complete cassette, and sent to the laboratory.

The laboratory equipment is adapted to the cassettes and test  
5 tubes that are used by the farmers served by that laboratory. Further, laboratory equipment, cassettes and test tubes, vary quite much from country to country.

Further, the sample tubes are typically prepared with a preservative prior to milk sampling, which preservative shall  
10 restrain the milk from turning to sour before the samples have been delivered to the laboratory and been analyzed. This preservative is to be dissolved in the milk, which typically takes a period of time, during which the increase of bacteria in the milk speeds up, whereby the risk that the milk turns to sour  
15 increases.

One prior art milk sampling device is disclosed in EP 0 564 023 A1 (LELY/MAASLAND). This device is provided with a cassette formed as a rotating box in which, along its circumference, milk sample collecting elements can be arranged. The filling member  
20 is disposed in a fixed position, while the collecting elements can be placed successively under the filling member. The filling member is further provided with a vertically movable type of injection needle to be inserted into the collecting elements. In this construction, the cassette and the injection needle have to  
25 be moved synchronously, which requires specific measures to be taken.

Besides, in case of a relatively large number of collecting elements, the space in the box is insufficiently utilized. Therefore, the cassette occupies relatively much space, which in  
30 view of the extensive equipment present in milking systems of today, is experienced as a drawback.

WO 01/74149

PCT/SE01/00676

Another prior art milk sampling device is depicted in EP 0 749 681 A1 (LELY/MAASLAND). This device is provided with a removable cassette in which milk sample collecting elements can be placed, and at least one filling member capable of being placed successively above various collecting elements and bringing milk samples, taken from milk provided by an automatic milking machine, to the respective collecting elements. Guide means is provided for supporting the filling member such that the filling member is moved, by successively increasing and decreasing the distance between the guide means and the cassette, from a position above a collecting element to an adjacent position above a nearby situated collecting element. In such manner the filling member may step from collecting element to collecting element along a predetermined fixed zigzag formed closed path.

This device has a simple design, but the movement of the filling member is not flexible since it is determined by said fixed path. This may be a major drawback if a single collecting element is to be used for collecting a second non-consecutive sample, e.g. for sampling a cow a second time a number of hours later, as the guide means may have to step through a relatively long path before reaching the collecting element in question.

A further drawback of both these prior art milk sampling devices is that they are designed to fit only one cassette size. As there exist different standards of cassettes and sample collecting elements in different countries a device has to be manufactured in various designs if it is to be put on several markets.

Further, there is a certain risk of mixing samples at the milking farm, during transport, or at the laboratory since the individual sample collecting elements are only identified through their respective positions in the cassette.

If the individual sample collecting elements are removed from the cassette of the milk sampling device and placed in other cassette or box for being dispatched to the laboratory, this risk of mixing samples is considerably increased as well as such an approach is time consuming, labor intensive and thus costly.

Further, the above-mentioned documents neither address the apparent problem that the milk samples may turn sour before reaching the laboratory nor discuss the dissolving of a preservative in the milk samples.

#### **SUMMARY OF THE INVENTION**

The present invention seeks to provide a milk sampling apparatus and method, which avoid at least some of the problems associated with prior art devices.

More particularly, the invention seeks to provide such milk sampling apparatus and method, which are flexible and which filling member has a variable movement capability.

The invention further seeks to provide a milk sampling apparatus and method, in which cassettes of various designs and sizes can be placed.

The invention further seeks to provide a milk sampling apparatus and method, which are capable of being adaptable for two-way communication with an automated milking system.

The invention further seeks to provide a milk sampling apparatus and method, in which milk samples can be preserved by adding a preservative to them.

The invention further seeks to provide such milk sampling apparatus and method, in which the preservative and the milk can be mixed appropriately.

The invention further seeks to provide a milk sampling apparatus and method, which are effective, fast, accurate, reliable, safe, easy to use, and of low cost.

5 According to one aspect of the present invention there is provided a milk sampling apparatus for use with an automated milking system, said apparatus comprising a cassette wherein milk sample collecting elements are placed, and at least one filling member capable of being placed above a selected one  
10 of said milk sample collecting elements by means of a positioning system, and capable of bringing a milk sample, representatively taken from milk yielded during a milking of an animal by means of said automated milking system, into said selected one of said milk sample collecting elements,  
15 characterized in that said position system comprises an arm extending a first direction (Y) in a plane (XY) above said milk sample collecting elements being movable in a second direction (X) in said plane (XY), said first (Y) and second (X) directions being orthogonal; a first runner holding said  
20 filling member and being movable along said arm; and first and a second drive means, wherein said first drive means is effective to move said arm in said second direction (X) in response to a first provided signal value or a first provided number of pulses and said second drive means is  
25 effective to move said first runner along said arm (Y direction) in response to a second provided signal value or a second provided number of pulses to position said filling member above said selected one of said milk sample collecting elements.

30 According to a further aspect of the present invention there is provided a method for milk sampling in a milk sampling apparatus comprising a cassette wherein milk sample collecting elements are placed, and at least one filling  
35 member movable above said milk sample collecting elements, and capable of bringing a milk sample, representatively taken from milk yielded during a milking of an animal by

5a

means of an automated milking system, into any one of said milk sample collecting elements, characterized by moving said filling member to a position above a selected one of said milk sample collecting elements by means of moving an arm, which extended in a first direction (Y) in a plane (XY) above said milk sample collecting elements, in a second direction (X) in said plane (XY) by means of a first drive means and in response to a first provided signal value or a first provided number of pulses, said first (Y) and second (X) directions being orthogonal; and moving a first runner holding said filling member along said arm by means of a second drive means and in response to a second provided signal value or a second provided number of pulses; and bringing said milk sample into said selected one of said milk sample collecting elements.

The present invention is directed to a milk sampling apparatus and method that comprise a flexible filling member movement capability, wherein the filling member can be automatically positioned above a milk sample collecting element placed in a cassette of the apparatus, independently of where the collecting element is placed in the cassette, e.g. by just providing the coordinates for the position of the collecting element.

The flexible positioning is obtained by means of a positioning system, which makes use of the movement mechanism of a conventional XY recorder, for moving the filling member in a plane above the cassette.

The positioning system comprises an arm extending in a first direction, or Y direction, in the plane and being movable in a second direction, or X direction, in said plane. A runner is further provided, at which the filling member is mounted, the runner being movable along the arm. In order to move the arm and the runner two drive means, preferably servo-operated motors, are provided. By means of e.g. supplied

5b

voltages or number of pulses corresponding to the coordinates for the position of the milk sample collecting element, the drive means are effective to position the filling member at said location.

5

A major advantage of the invention is that it provides for a very flexible use, particularly as regards the movement of the filling member. Indeed, the filling member may be directly moved to any desired position (in terms of position coordinates) above the cassette, thus not unduly restricting the movement of the

10

filling member to predetermined positions along a predetermined path.

A further advantage of the invention is the usability with a large range of cassette and sample collecting element designs and sizes, i.a. due to the variable movement capability of the flexible filling member.

Further characteristics of the invention and advantages thereof will be evident from the following detailed description of embodiments of the invention.

#### 10 **BRIEF DESCRIPTION OF THE DRAWINGS**

The present invention will become more fully understood from the detailed description of embodiments of the present invention given hereinbelow and the accompanying Figs. 1-4, which are given by way of illustration only, and thus are not limitative of the present invention.

Fig. 1 displays schematically an embodiment of a milk sampling apparatus according to the present invention.

Figs. 2a-d illustrate four different embodiments of an XY-positioning system as being included in the milk sampling apparatus of Fig. 1.

Fig. 3 is a schematic block diagram of an embodiment of the milk sampling apparatus according to the present invention connected to an automated milking system, the sampling apparatus being adapted for two-way communication with the milking system.

25 Fig. 4 illustrate an embodiment of a shaking table as being included in the milk sampling apparatus of Fig. 1.

#### **DETAILED DESCRIPTION OF EMBODIMENTS**

In the following description, for purposes of explanation and not limitation, specific details are set forth, such as

particular techniques and applications in order to provide a thorough understanding of the present invention. However, it will be apparent to one skilled in the art that the present invention may be practiced in other embodiments that depart from these specific details. In other instances, detailed descriptions of well-known methods and apparatuses are omitted so as not to obscure the description of the present invention with unnecessary details.

Referring to Fig. 1 an embodiment of a milk sampling apparatus 1 according to the present invention comprises a stainless steel chassis 3 at which a shaking or vibrating table 5 is mounted. At table 5 one, or preferably two, cassettes 7 are removably mounted, in which cassette(s) milk sample collecting elements or tubes 9 are placed. Tubes 9 are arranged vertically with their openings pointing upwards.

A rubber sheet or insert 11 may be provided at the upper surface of table 5 having a punched through opening, wherein cassette(s) 7 can be arranged. The opening is made such that a close fit between cassette(s) 7 and rubber sheet 11 is obtained. Sheet 11 is preferably about 25 mm thick and may be of any other suitable material such as e.g. steel. The provision of rubber sheet 11 allows for possibilities to tailor-make the sampling apparatus to fit with a particular cassette or a particular practice or standard.

The lateral dimensions of chassis 3, shaking table 5 and rubber sheet 11 are preferably such that there is room for two conventional German sample cassettes, which are the largest cassettes the present inventors have found on the market. In such a cassette there is room for 70 sample tubes and 140 sample tubes will probably be sufficient in order to handle 50 milking animals during a period of 24 hours if each animal yields one sample per milking. If a single sample tube may be used more than one time for a given animal that presents for milking

during the 24 hours interval, the milk sample device can handle even more animals or, alternatively, the number of sample tubes may be reduced.

5 Further, the milk sampling apparatus comprises a collection vessel 13, which can be arranged in fluid connection with a milk passage, e.g. vessel or conduit, of an automated milking station to which the milk sampling apparatus is connectable via adjustment of a valve (not shown in Fig. 1).

10 Preferably, collection vessel 13 is by means of a vacuum supplied hose connected to a likewise vacuum supplied flow meter of the automated milking system, through which flow meter all milk as drawn from a milking animal is passed. A representative milk amount, typically about 2 % (corresponding to about half a liter) of the total milk amount from a milking, is by way of  
15 gravity flowed into collection vessel 13 when a sample is to be taken. The hose has in a preferred embodiment an inner diameter of 10 mm and a thickness of material of about 3 mm.

20 Collection vessel 13 is also connected to a source of compressed air via a pressure regulator (not shown in Fig. 1) for the supply of air.

Further, two different discharge outlets are arranged at different heights of collection vessel 13, of which the upper outlet 15 is connected to a discharge line (not shown in Fig. 1) and the lower outlet 17, being located at bottom of vessel 13,  
25 is via a conduit connected to a hose (not shown in Fig. 1) arranged in a spring biased reel 23.

The milk sampling apparatus of Fig. 1 comprises further a servo-operated XY-positioning system or table 25 arranged parallel with and above cassette(s) 7. XY-positioning system 25 is a  
30 device adapted for flexible positioning of a filling member 27 above a selected one of the plurality of sample tubes in cassette(s) 7. XY-positioning system 25 comprises two servo

WO 01/74149

PCT/SE01/00676

systems 29, 31, of which a first moves an arm 34 in the X-direction such that the position of the arm is proportional to a first provided signal value (e.g. a voltage) or a first provided number of pulses. The filling member, being connected to the hose of hose reel 23, is mounted on a runner 32 that is movable along the arm in the Y-direction such that the position of runner 32 and filling member 27 is proportional to a second provided signal value (e.g. voltage) or a second provided number of pulses. The operation is thus similar to a conventional XY recorder.

A processing means 33 is provided for two-way communication with the automated milking system, which will be further depicted below with reference to Fig. 3. Processing means 33 controls the position of the filling member as well as all valves included in the apparatus.

All valves are preferably of hose clamping kind such that no pockets or spaces, where dirt and bacteria may settle, exists. The hose clamps are preferably electro-mechanical, wherein the hose is pinched by means of a spring and opened by means of an electromagnet. Pneumatic valves may alternatively be used.

The milk sampling apparatus may preferably be provided with wheels 35 and a handle 37, such that the apparatus may easily be transported by the farmer. The apparatus comprises also a cover 39 to protect from dirt, the cover being preferably transparent such that the operation of the apparatus may be observed by the farmer. Furthermore, the apparatus is designed such that the distance between the cassette and the floor is large and the handling of the sample tubes takes place from above. In such an instance the risk of contamination of the samples is minimized and a good hygiene is safeguarded.

Next, with reference to Figs. 2a-d, four different designs of the XY-positioning system as being part of the milk sampling apparatus of Fig. 1 will briefly be discussed.

A simple and low cost implementation of the transmission of force, as illustrated in Fig. 2a, is the use of synchronous transmission or drive belts 41. Using such transmission a reliable design, which require no maintenance, is achieved. The precision is not excellent, but acceptable for the present purpose. The force the transmission has to cope with, is only the tension force from the hose reel and any occurring friction.

An alternative implementation, shown in Fig. 2b, uses linear rails with runners. The transmission of the runners is realized by means of gear racks 43 along rails 44, 45 and motors 29, 31 mounted on respective runners 46, 47, wherein rail 44 is firmly mounted on runner 47. The performance of this implementation would be similar to that of the implementation of Fig. 2a. One drawback using this implementation, however, is that more cords must be flexible and movable.

A further alternative, shown in Fig. 2c, is implementing a rotatable trapezoid threaded screw 49 and a runner or nut 50 for transmission, gearing, and load carrying in the X direction, said runner being prevented from being rotated. The movement in the Y direction is realized by a wire 51, which is journalled 53 at runner 50 and is attached to a further runner 54, which in turn is attached to a biased slidable spring 55. In this alternative, the spring 55 and the end of wire 51 attached to the spring may be considered to constitute arm 34 of Fig. 1.

A still further alternative implementation, shown in Fig. 2d, uses a respective rotatable screw 56 and a respective runner 57 for transmission, gearing, and load carrying in the respective direction. In such instance weak step motors may be used.

WO 01/74149

PCT/SE01/00676

It shall be appreciated that any combination of the above discussed transmission implementations may be employed. The movements in the X and Y directions have different prerequisites in terms of e.g. available space.

5 Next, with reference to Fig. 3, which is a schematic block diagram of the inventive milk sampling apparatus including a two-way communication interface to the automated milking system, said milk sampling apparatus, and particularly the function thereof, will be further described.

10 When a sample is to be taken an initiating signal from a processing means 59 of automated milking system 61 is via line 63 sent to processing means 33 of milk sampling apparatus 1 together with XY coordinates for the sample tube to be used for the current sample. Processor 33 sends a control signal to open  
15 valve 65 and a representative fraction of milk from a milking, is then by way of gravity flowed from automated milking system 61, through conduit 67 and into collection vessel 13. At this point all other valves 69, 71, 73 are closed. Meanwhile processor 33 sends control signals to servo systems 29, 31  
20 instructing them to move filling member 27 to the coordinates as received from automated milking system 61.

Further, when all milk has been flowed into vessel 13 compressed air is supplied to the vessel through line 75 by opening valve 69, which is controlled by processor 33. During the supply of  
25 compressed air valve 65 is either opened or closed; in the latter instance the amount of air supplied has to be controlled such that the pressure in collection vessel 13 does not raise unduly much. Line 75 ends inside vessel 13 close to the bottom thereof and by blowing air through the milk it is prevented from  
30 being bedded, which would not yield a representative sample.

Next, valve 71 is opened by processor 33 such that a major portion of the milk is evacuated through line 77. The milk left

WO 01/74149

PCT/SE01/00676

in vessel 13 is given by the cross sectional area of vessel 13 and the height at which outlet 15 is arranged. A typical volume is 8-16 ml. The evacuated milk may be thrown away, recirculated to automated milking system 61, or transported to e.g. a milk storage tank (not shown in Fig. 3).

Valve 71 is closed and valve 73 is opened. At this time the filling member is at place at the given coordinates, i.e. above the selected sample tube. By means of the compressed air the milk sample is flowed out of outlet 17, through a conduit 19 and a hose 21, and out through the orifice of filling member 27, and finally collected in the selected sample tube. The air is blown for a period of time such that it is safeguarded that the entire milk sample has been transferred to the sample tube. The vertical distance between the orifice of filling member 27 and the upper end of the sample tube has to be small enough to secure that the entire milk sample will be collected in the correct tube.

When the sample has been collected, processor 33 sends a signal to a motor 79, which shakes shaking table 5 and thus the sample tubes, see further the description with reference to Fig. 4 below.

Finally microprocessor 33 sends a completion message to automated milking system via line 81.

It shall be appreciated that all valves and all motors are controlled by means of processor 33, which is indicated by control lines 83.

Further, processor 33 is preferably provided with a memory, suitable software and a power supply (not shown in Fig. 3). Also, the motors and valves are power supplied in any suitable manner. Preferably, the milk sampling apparatus is provided with a battery for the supplying of power, and thus no electrical

connections have to be made at the installation of the apparatus.

The flexible function of the milk sampling apparatus implies that the filling of the sample tubes may be performed in any order. The filling member may be directly moved to any desired position (in terms of position coordinates) above the cassette. Hence, no undue restriction of the movement of the filling member to predetermined positions along a predetermined path is imposed.

10 Further, if a single sample tube is to be used also for collecting a second non-consecutive sample, e.g. for sampling a cow a second time some hours later, it is readily done simply by instructing the servo systems of the XY-positioning system to move the filling member to the coordinates in question.

15 Cleaning of all parts of the milk sampling apparatus 1 that come into contact with milk may easily be performed by using the conventional cleaning of the automated milking system.

By providing a drain outlet 101 below any suitable XY coordinate position and by moving the filling member 27 to this position cleaning is simply performed by opening valves 65 and 73 (and possibly by opening a valve (not shown) at the automated milking station side of conduit 67) and letting the cleaning fluid pass through line 67, vessel 13, lines 19, 21 and filling member 27 and be discharged through said drain outlet. Valve 73 may be repeatedly closed and opened during the cleaning process such that vessel 13 becomes repeatedly entirely filled with cleaning fluid to enhance cleaning of vessel 13. Valve 69 may be opened such that compressed air is mixed with the cleaning fluid and if it is desirable to also clean line 77, valve 71 is opened.

30 If a more frequent cleaning is desired, e.g. subsequent to each sample being taken out, cleaning fluid may be supplied through line 77 by means of connecting it to a pump and a cleaning fluid

supply (not shown in Fig. 3). In order to minimize the distance that the filling member has to transverse in order to reach a drain outlet, drain outlet channels 102 can be arranged along one or more sides of the milk sampling apparatus. If such channels are arranged along all sides filling member 27 has never to be moved more than half the width of the milk sampling apparatus.

Two-way communication between the processor of the automated milking machine and the processor of the milk sampling apparatus according to the present invention is realized through communication bus 63, 81. Connection of this bus and of milk conduit 67 are the only connections that necessarily have to be performed at installation of the milk sampling apparatus. However, also connection of conduit 75 to the source of compressed air is conveniently performed at installation as well as connection of conduit 77 if the milk flowed through this conduit is to be recovered.

Communication from the automated milking station to the milk sample apparatus may preferably include various kinds of control commands and interrogation and information messages, whereas communication in the opposite direction include various kinds of information and alarm messages.

Communication from the automated milking station to the milk sampling apparatus may particularly include any of:

- i. Initiation of milk sampling (XY coordinates for the selected sample tube is included in the message).
- ii. Initiation of a cleaning cycle, which instructs processor 33 of the milk sampling apparatus to take the steps as described above.
- iii. Instructions that automatic cleaning shall be performed after each sample being taken.

Communication from the milk sampling apparatus to the automated milking station may particularly include any of:

- i. Information of successful completion of milk sampling.
- ii. Electric error alarming message.
- 5 iii. Loose cover alarming message.
- iv. Erroneously placed sample tube or missing sample tube alarming message.

Various kinds of alarming functions can be arranged by providing the milk sampling apparatus with suitable sensors 103.

10 Finally, with reference to Fig. 4, which illustrates an embodiment of shaking table 5 as being part of the milk sampling apparatus 1 of Fig. 1, this aspect of the invention will be described closer.

The sample tubes are typically prepared with a preservative  
15 prior to milk sampling, which preservative shall restrain the milk from turning to sour before the samples have been delivered to the laboratory and been analyzed. This preservative is to be dissolved in the milk. Such dissolving typically takes a certain period of time, during which the increase of bacteria in the  
20 milk speeds up, and thus the risk that the milk turns to sour increases.

The sample tubes are typically delivered to the farmer in a cleaned and preservative prepared condition. The preservative may be 2-bromo-2-nitropropane-1,3-diol, also widely commercially  
25 available under the trademark BRONOPOL, which is crystallized in the bottom of the tubes. The cassette with the prepared sample tubes are typically to be used during a 24 hours period of time, which implies that that the tubes are standing for such a period in the milk sampling apparatus in a milk farm environment  
30 without any individual covers. It is under such circumstances

desirable to safeguard a fast dissolving of the preservative in the milk. The shaking table 5 of the milk sampling apparatus according to the present invention is thus used to accelerate this dissolving by shaking sample tubes 9.

5 The shaking table in Fig. 4 is arranged on chassis 3 of Fig. 1 by means of four elastic isolator feet 85, preferably made of rubber or plastic, of which only two are indicated in Fig. 4. Two cassettes 7 with sample tubes 9 are arranged on shaking table 5 as schematically illustrated in Fig. 4. The table 5 is  
10 being shaken by means of motor 79 rotating an eccentric disk 83. The shaking table 5 can be moved in two transverse directions (X and Y directions) and rotated around a third axis, the Z axis, being perpendicular to X and Y dimensions.

The shaking operation may be affected by the mutual placement of  
15 various parts of the milk sampling apparatus such as shaking table, motor, eccentric disk, cassette, sample tubes and elastic isolator feet. Furthermore, the weights and weight distributions of the eccentric disk and of the shaking table may be altered. System constants such as rotation speed of the eccentric disk,  
20 spring constant and damping constant of the elastic isolator feet may also be altered. All these parameters affect the shaking function and thus a number of actions may be taken in order to properly design the shaking table to yield an appropriate agitation of the samples. Other shaking tables that  
25 may be used in the present invention are disclosed in U.S. Patent Nos. 4,102,649 and 5,259,672.

If no agitation of the sample tubes is performed, the preservative has partly or completely become dissolved after  
30 about an hour, but this may in some applications be a too long period of time since the growth of bacteria has started. By using the shaking table of the present invention the dissolving

of preservative in milk is strongly accelerated. Preferably, shaking is performed subsequent to each taken milk sample.

Other dissolving acceleration means may be used as a complement or instead of the shaking table, such as ultrasonic devices or  
5 any other suitable agitating means known in the art.

Further, it shall be appreciated that a representative small amount (e.g. 8-16 ml) of milk can be sampled directly from the automated milking system, see e.g. U.S. Patent No. 5,303,598. In such version of the present invention collection vessel 13 of  
10 Fig. 1 may be dispensed with and a small portion of milk (typically in the order of  $10^{-4}$  of the total amount of milk) may be flowed from the automated milking system, through a hose and a filling member, and into a sample tube, preferably during the entire time of the milking of an animal in order to obtain a  
15 representative sample.

It will be obvious that the invention may be varied in a plurality of ways. Such variations are not to be regarded as a departure from the scope of the invention. All such modifications as would be obvious to one skilled in the art are  
20 intended to be included within the scope of the appended claims.

**CLAIMS**

1. A milk sampling apparatus for use with an automated milking system, said apparatus comprising a cassette wherein milk sample collecting elements are placed, and at least one filling member capable of being placed above a selected one of said milk sample collecting elements by a positioning system, and capable of bringing a milk sample, representatively taken from milk yielded during a milking of an animal by said automated milking system, into said selected one of said milk sample collecting elements, characterized in that said position system comprises

- an arm extending a first direction (Y) in a plane (XY) above said milk sample collecting elements being movable in a second direction (X) in said plane (XY), said first (Y) and second (X) directions being orthogonal;
- a first runner holding said filling member and being movable along said arm; and
- first and a second drive means, wherein
- said first drive means is effective to move said arm in said second direction (X) in response to a first provided signal value or a first provided number of pulses and said second drive means is effective to move said first runner along said arm (Y direction) in response to a second provided signal value or a second provided number

of pulses to position said filling member above said selected one of said milk sample collecting elements.

2. The milk sampling apparatus as claimed in claim 1, wherein said first and second drive means comprise a respective servo-operated motor.

3. The milk sampling apparatus as claimed in claim 1 or 2, wherein any one of said first and second drive means is effective to move by a drive belt.

4. A milk sampling apparatus as claimed in claim 1, wherein said first drive means comprises a first servo-operated motor, which together with said arm are rigidly mounted on a second runner, said second runner being moved by said first motor cooperating with a first gear rack.

5. The milk sampling apparatus as claimed in claim 4, wherein said second drive means comprises a second servo-operated motor, which is rigidly mounted on said first runner, said first runner being moved by said second motor cooperating with a second gear rack.

6. The milk sampling apparatus as claimed in claim 2, wherein said arm is mounted on a second runner, which is threaded on a screw and prevented from being rotated, and wherein the motor of said first drive means is effective to move said arm by rotating said screw.

7. The milk sampling apparatus as claimed in claim 6, wherein said first runner is threaded on a second screw and prevented from being rotated, and wherein the motor of said second drive means is mounted on said second runner and effective to move said first runner by rotating said second screw.

8. The milk sampling apparatus as claimed in claim 6, wherein said first runner is spring biased and said second drive means is effective to move said first runner by a drive wire.

9. The milk sampling apparatus as claimed in any one of claims 1 to 8, wherein, said milk sampling apparatus is by said positioning system, capable of bringing a second non-consecutive milk sample, representatively taken from milk yielded during a second milking of said animal by said automated milking system, into said selected one of said milk sample collecting elements.

10. The milk sampling apparatus as claimed in any one of claims 1 to 9, wherein said cassette is held at place by an insert.

11. The milk sampling apparatus as claimed in claim 10, wherein said insert has an opening, in which said cassette fits.

12. The milk sampling apparatus as claimed in claim 10 or 11, wherein said milk sampling apparatus comprises a second cassette wherein milk sample collecting elements

are placed, said second cassette being held at place by said insert, and said at least one filling member is capable of being placed above a selected one of said milk sample collecting elements in said second cassette.

13. The milk sampling apparatus as claimed in any one of claims 1 to 12, wherein the vertical distance between said filling member and the upper end of said selected one of said milk sample collecting elements is small when said filling member is positioned above said selected one of said milk sample collecting elements so as to ensure that said milk sample is brought into said selected one of said milk sample collecting elements in its entirety.

14. The milk sampling apparatus as claimed in any one of claims 1 to 13, comprising a drain outlet, and wherein said filling member is capable of being placed above said drain outlet by said positioning system, and capable of bringing cleaning fluid into said drain outlet.

15. The milk sampling apparatus as claimed in claim 14, comprising drain outlet channels along at least one side of said milk sampling apparatus.

16. The milk sampling apparatus as claimed in any one of claims 1 to 15, further comprising processing means arranged to receive an indication of said selected one of said milk sample collecting elements and to control said first and second drive means to move said arm and said first runner such that said filling member is positioned

above said selected one of said milk sample collecting elements.

17. The milk sampling apparatus as claimed in any one of claims 1 to 15, further comprising processing means arranged for two-way communication with said automated milking system.

18. The milk sampling apparatus as claimed in claim 17, further comprising a sensor connected to said processing means wherein said processing means is arranged for sending an alarm signal to said automated milking system in dependence on the sensing of said sensor.

19. The milk sampling apparatus as claimed in any one of claims 1 to 18, further comprising agitating means capable of agitating each of said milk samples.

20. The milk sampling apparatus as claimed in claim 19, wherein said agitating means comprise a shaking table at which said cassette is removably mounted.

21. A method for milk sampling in a milk sampling apparatus comprising a cassette wherein milk sample collecting elements are placed, and at least one filling member movable above said milk sample collecting elements, and capable of bringing a milk sample, representatively taken from milk yielded during a milking of an animal by an automated milking system, into any one of said milk sample collecting elements, characterized by

- moving said filling member to a position above a selected one of said milk sample collecting elements by moving an arm, which extended in a first direction (Y) in a plane (XY) above said milk sample collecting elements, in a second direction (X) in said plane (XY) by a first drive means and in response to a first provided signal value or a first provided number of pulses, said first (Y) and second (X) directions being orthogonal; and moving a first runner holding said filling member along said arm by a second drive means and in response to a second provided signal value or a second provided number of pulses; and

- bringing said milk sample into said selected one of said milk sample collecting elements.

22. The method as claimed in claim 21, wherein any one of said first and second drive means is effective to move by a drive belt.

23. The method as claimed in claim 21, wherein any one of said first and second drive means is effective to move by a gear rack.

24. The method as claimed in claim 21, wherein any one of said first and second drive means is effective to move by a rotatable screw.

25. The method as claimed in claim 21, wherein any one of said first and second drive means is effective to move by a drive wire.

26. The method as claimed in any one of claims 21 to 25, wherein a second non-consecutive milk sample, representatively taken from milk yielded during a second milking of said animal by said automated milking system, is brought into said selected one of said milk sample collecting elements by said drive means.

27. The method as claimed in any one of claims 21 to 26, further comprising holding said cassette in place by an insert.

28. The method as claimed in any one of claims 21 to 27, comprising placing said filling member above a drain outlet by said drive means, and bringing cleaning fluid into said drain outlet.

29. The method as claimed in any one of claims 21 to 28, further comprising receiving an indication of said selected one of said milk sample collecting elements and controlling said first and second drive means to move said arm and said first runner such that said filling member is placed above said selected one of said milk sample collecting elements.

30. The method as claimed in any one of claims 21 to 29, further comprising measuring a parameter of said milk sampling apparatus and sending an alarm signal to said automated milking system in dependence on said measured parameter.

31. The method as claimed in any one of claims 21 to 29, further comprising agitating each of said milk samples.

32. The method as claimed in claim 31, wherein said agitating is performed by shaking a shaking table at which said cassette is removably arranged.

33. The milk sampling apparatus as claimed in any one of claims 1 to 20, wherein the position of said selected one of said milk sample collecting elements in said plane (XY) is provided by a pair of coordinates and wherein said first and second drive means are effective to move in response to said pair of coordinates.

34. The milk sampling apparatus as claimed in any one of claims 1 to 20, wherein the position of said selected one of said milk sample collecting elements in said plane (XY) is provided by a pair of coordinates and wherein said arm and said first runner are moved in response to said pair of coordinates.

1/5

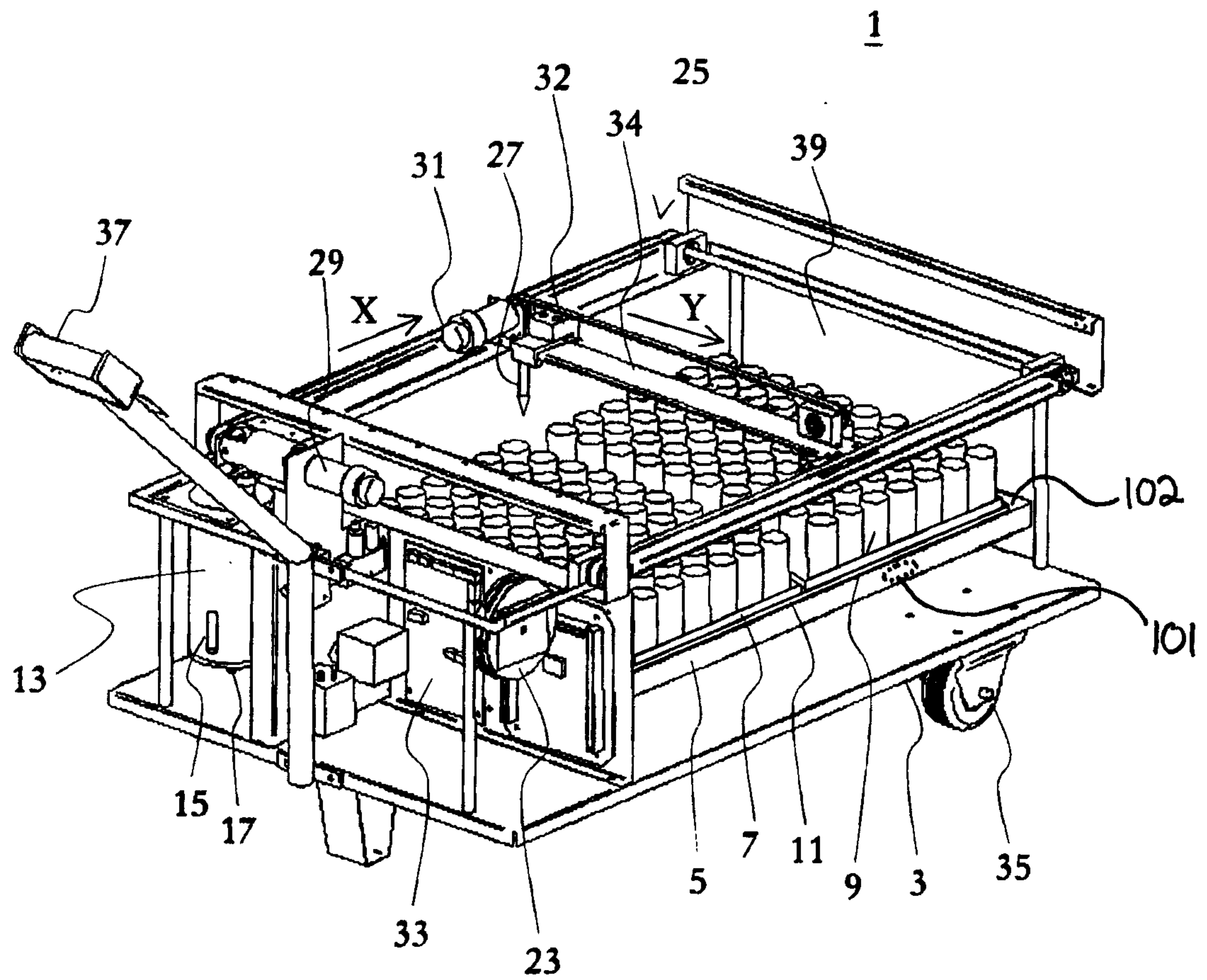

Fig. 1

2/5

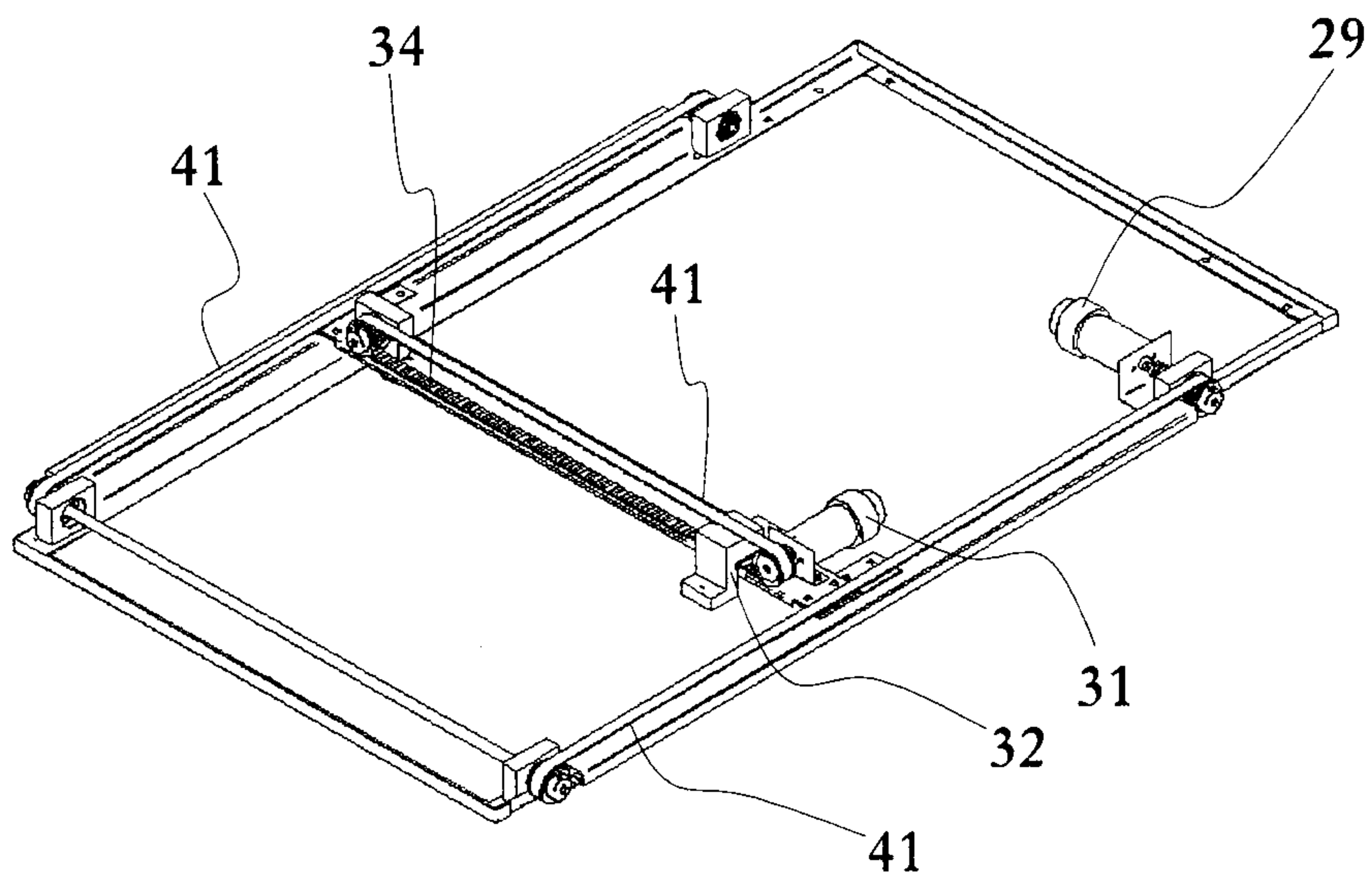

Fig. 2a

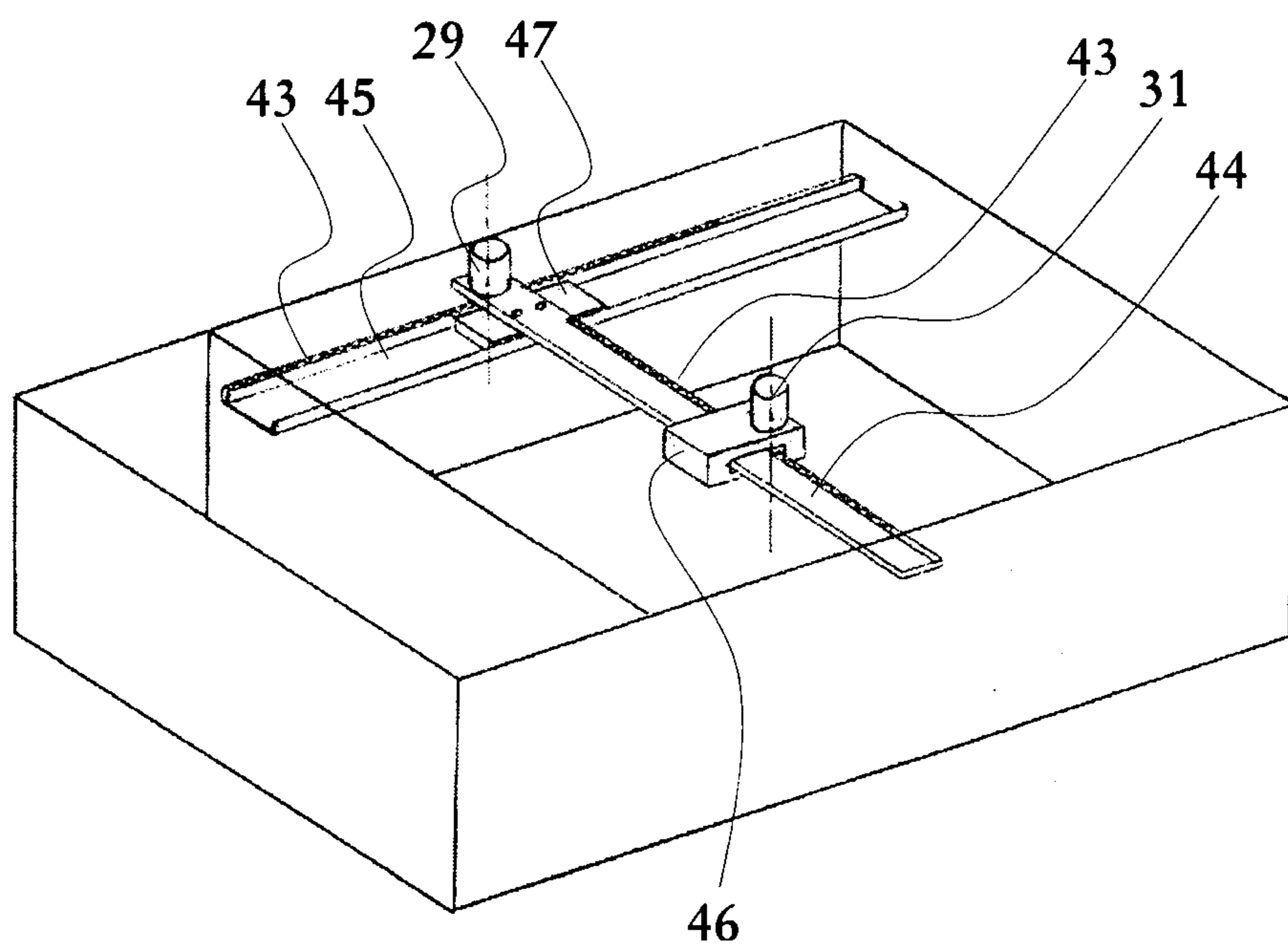

Fig. 2b

3/5

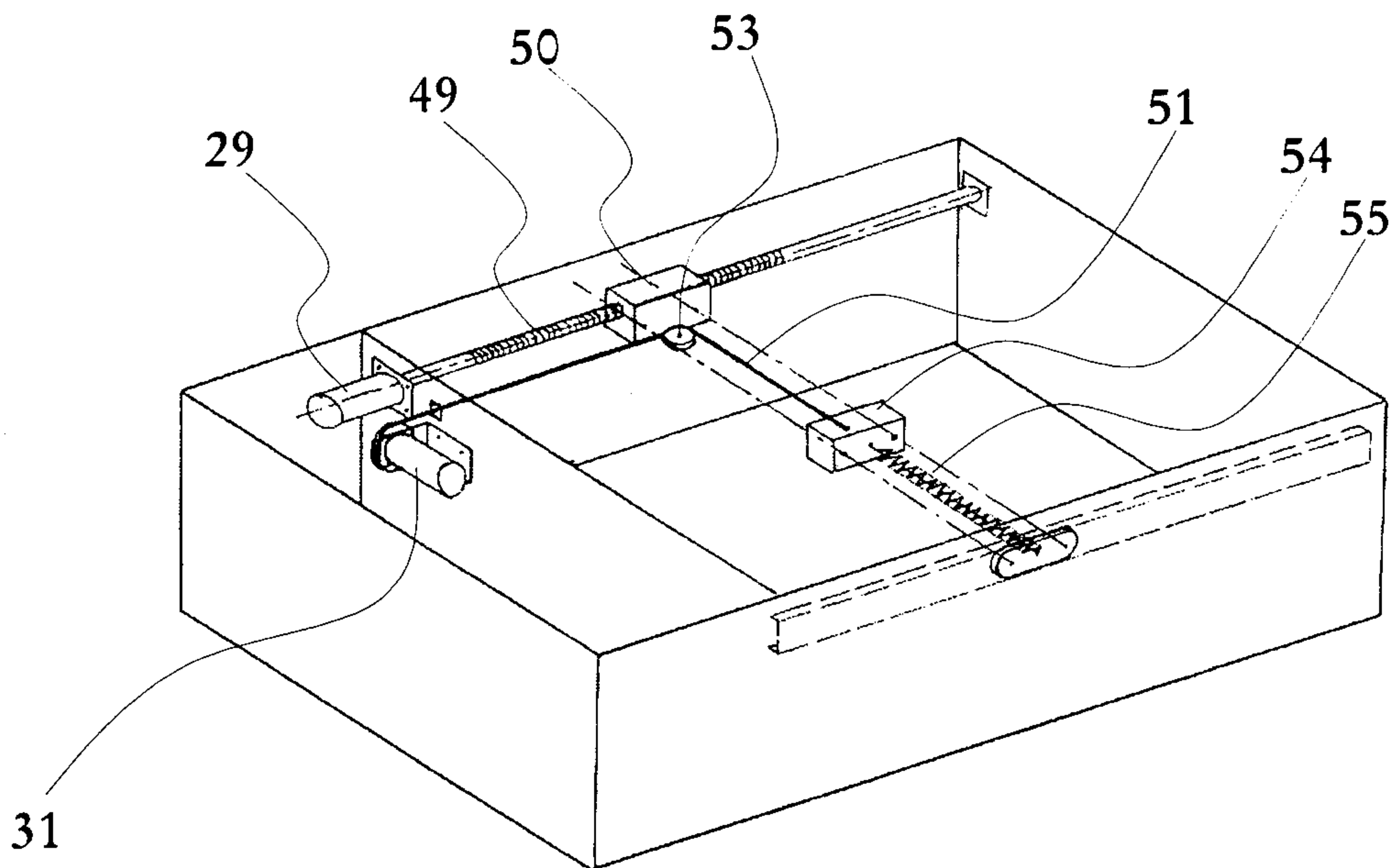

Fig. 2c

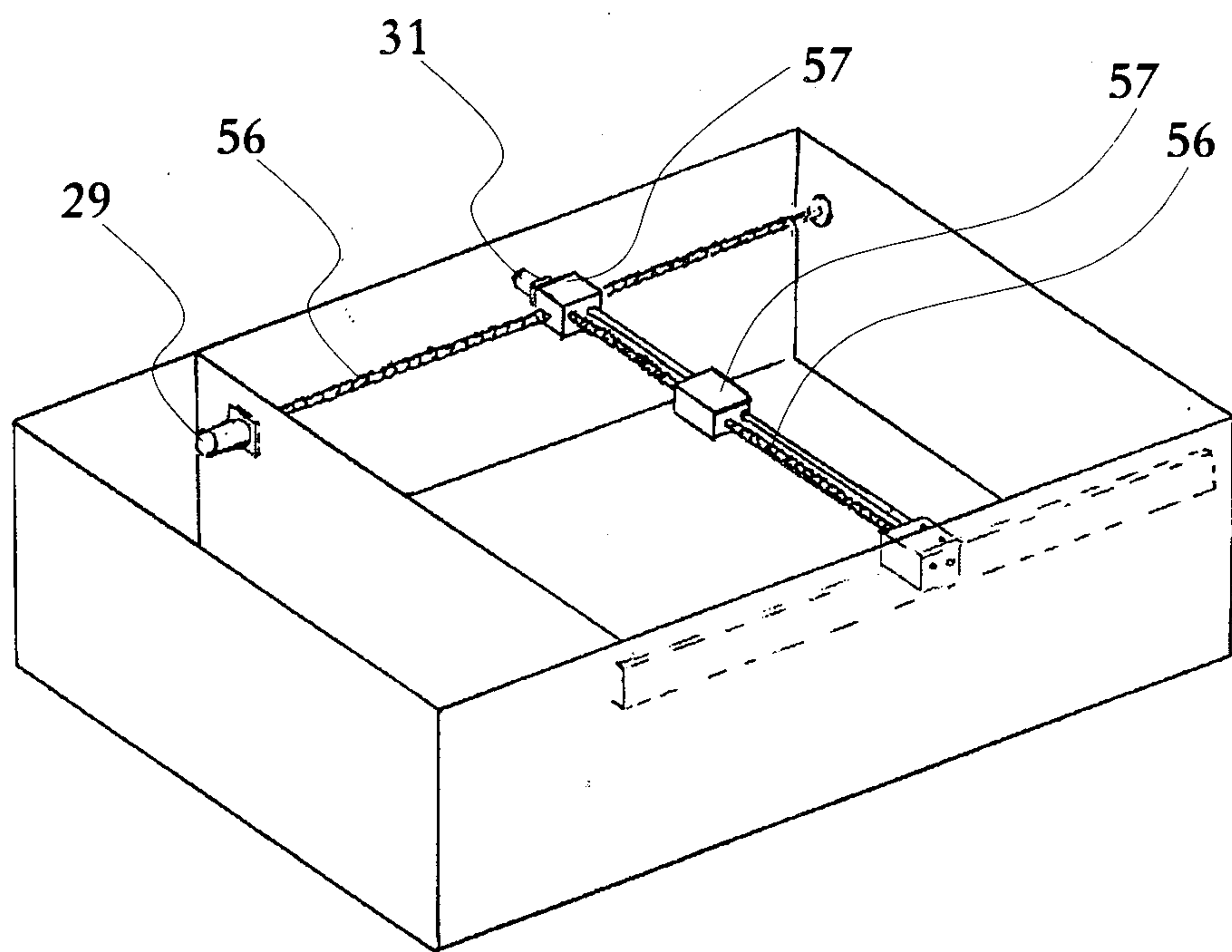

Fig. 2d

4/5

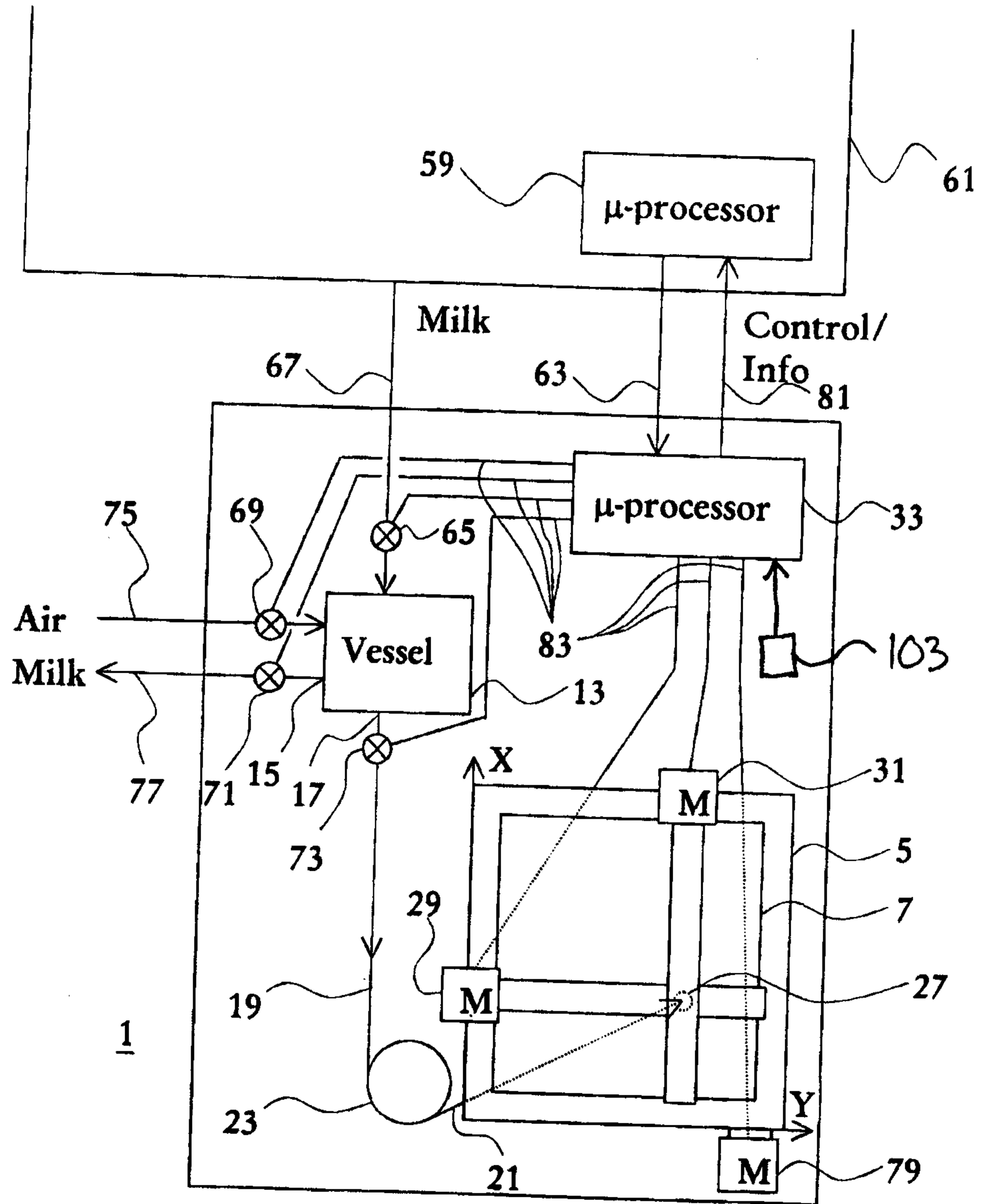

Fig. 3

5/5

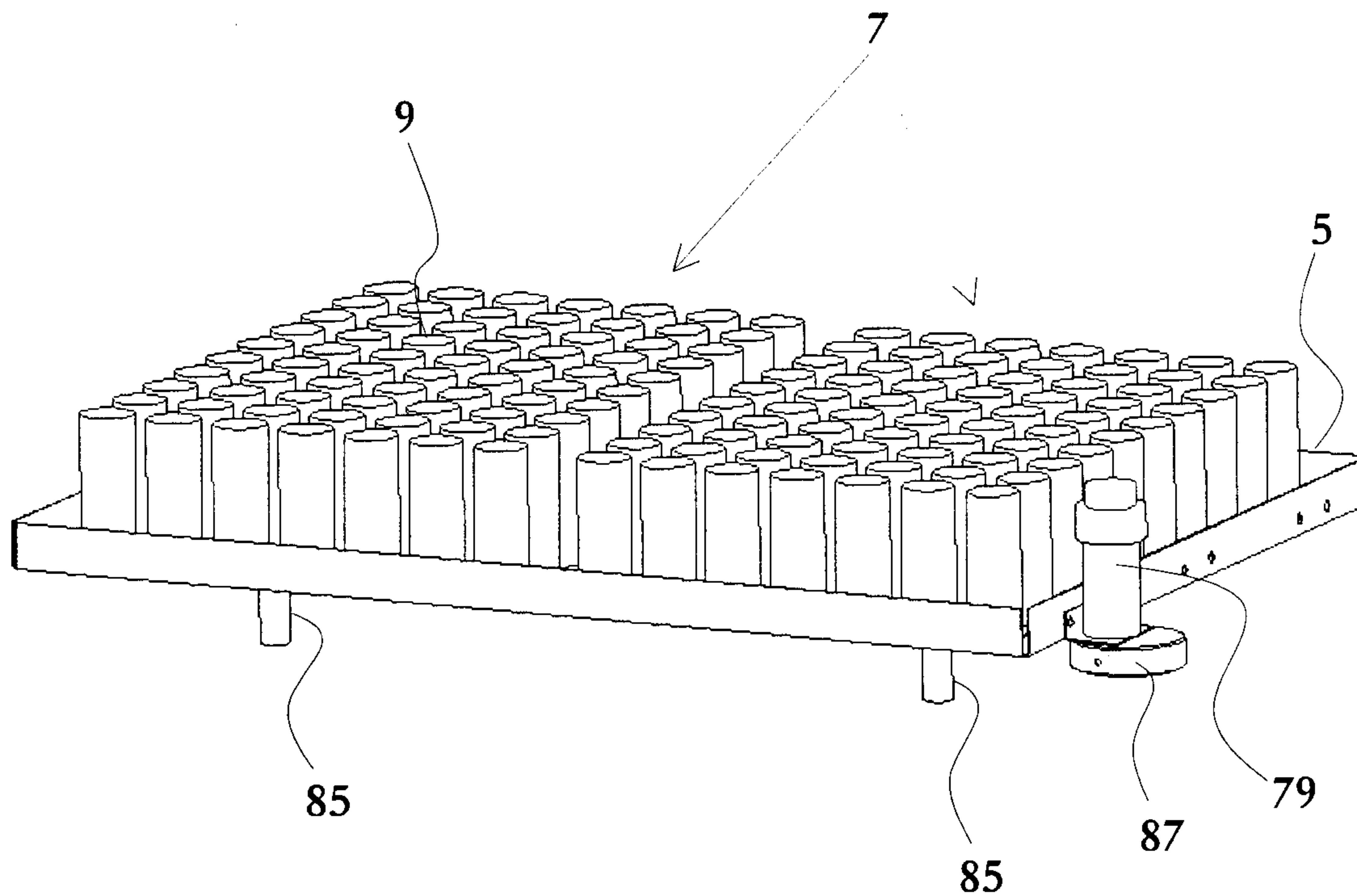

Fig. 4

