

(19) World Intellectual Property Organization
International Bureau



(43) International Publication Date
2 October 2008 (02.10.2008)

PCT

(10) International Publication Number
WO 2008/117296 A1

(51) International Patent Classification:

A61N 1/36 (2006.01) A61F 5/00 (2006.01)
A61B 5/00 (2006.01)

(74) Agent: SANFORD T. COLB & CO.; P.O. Box 2273,
76122 Rehovot (IL).

(21) International Application Number:

PCT/IL2008/000441

(81) Designated States (unless otherwise indicated, for every kind of national protection available): AE, AG, AL, AM, AO, AT, AU, AZ, BA, BB, BG, BH, BR, BW, BY, BZ, CA, CH, CN, CO, CR, CU, CZ, DE, DK, DM, DO, DZ, EC, EE, EG, ES, FI, GB, GD, GE, GH, GM, GT, HN, HR, HU, ID, IL, IN, IS, JP, KE, KG, KM, KN, KP, KR, KZ, LA, LC, LK, LR, LS, LT, LU, LY, MA, MD, ME, MG, MK, MN, MW, MX, MY, MZ, NA, NG, NI, NO, NZ, OM, PG, PH, PL, PT, RO, RS, RU, SC, SD, SE, SG, SK, SL, SM, SV, SY, TJ, TM, TN, TR, TT, TZ, UA, UG, US, UZ, VC, VN, ZA, ZM, ZW.

(22) International Filing Date: 30 March 2008 (30.03.2008)

(25) Filing Language: English

(26) Publication Language: English

(30) Priority Data:
60/908,482 28 March 2007 (28.03.2007) US

(71) Applicant (for all designated States except US):
METACURE LTD. [GB/GB]; Canon's Court, 22 Victoria Street, Hamilton, HM12 (BM).

(84) Designated States (unless otherwise indicated, for every kind of regional protection available): ARIPO (BW, GH, GM, KE, LS, MW, MZ, NA, SD, SL, SZ, TZ, UG, ZM, ZW), Eurasian (AM, AZ, BY, KG, KZ, MD, RU, TJ, TM), European (AT, BE, BG, CH, CY, CZ, DE, DK, EE, ES, FI, FR, GB, GR, HR, HU, IE, IS, IT, LT, LU, LV, MC, MT, NL, NO, PL, PT, RO, SE, SI, SK, TR), OAPI (BF, BJ, CF, CG, CI, CM, GA, GN, GQ, GW, ML, MR, NE, SN, TD, TG).

(72) Inventors; and

(75) Inventors/Applicants (for US only): SPEHR, Paul, Richard [US/US]; 120 Indian Pipe Trail, Medford, NJ 08055 (US). BITTON, Ophir [IL/IL]; 11B Dvora, 30900 Zichron Yaakov (IL). LEVI, Tamir [IL/IL]; Ein Haemek 30, 19250 Ein Haemek (IL). POLICKER, Shai [IL/US]; 258 W. Clinton Avenue, Tenafly, NJ 07670 (US).

Published:
— with international search report

[Continued on next page]

(54) Title: EATING SENSOR

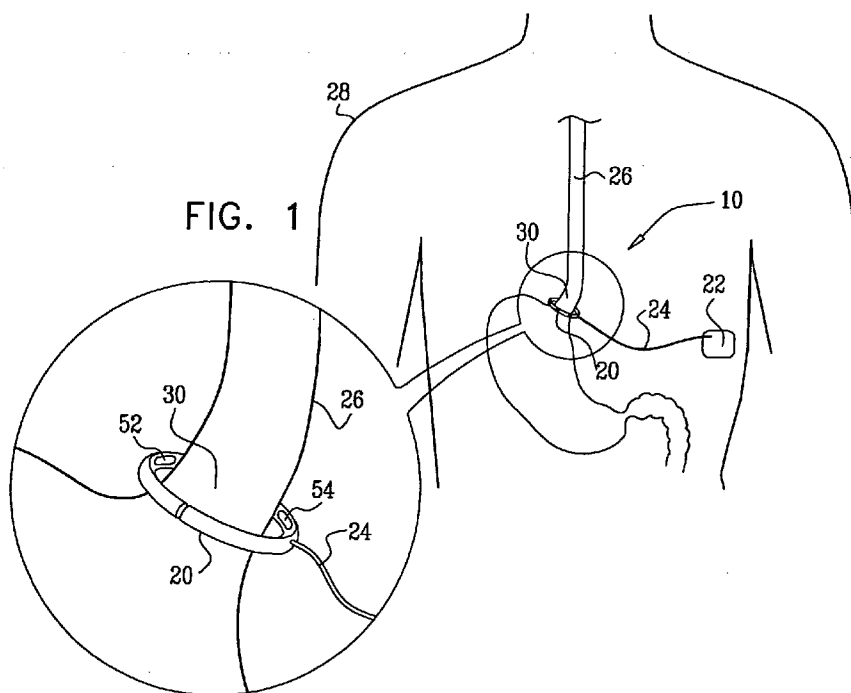

(57) Abstract: Apparatus (10) is provided, including a ring (20) configured to be secured around an esophagus (26) of a subject without being surgically coupled to the esophagus or any other tissue of the subject. A sensor (50) is coupled to the ring, and is configured to sense at least one property indicative of passage of food through the esophagus, the property selected from the group consisting of: a property of the esophagus, and a property of the food.

WO 2008/117296 A1



-
- *before the expiration of the time limit for amending the claims and to be republished in the event of receipt of amendments* — *the filing date of the international application is within two months from the date of expiration of the priority period*

EATING SENSOR**CROSS-REFERENCES TO RELATED APPLICATIONS**

The present application claims the benefit of US Provisional Patent Application 60/908,482 to Spehr et al., filed March 28, 2007, entitled, "Eating sensor," which is assigned to the assignee of the present patent application and is incorporated herein by reference.

FIELD OF THE INVENTION

The present invention relates generally to implantable medical devices, and specifically to methods and apparatus for sensing and analyzing eating.

BACKGROUND OF THE INVENTION

US Patent 6,735,477 to Levine, which is incorporated herein by reference, describes a system including a food intake detection unit, and a stimulator for applying electrical or chemical stimulation upon detection of the intake. In some embodiments, the intake detection unit includes a sensor that is located over (e.g., adjacent) the esophagus to detect whenever food is passing therethrough. The detection mechanism utilized may include, e.g., detection of changes in density of the esophagus, differences in the passage of light or sound waves, or peristaltic action. The food intake detection unit may be placed surgically directly on the esophagus, or, alternatively, may be implanted subcutaneously.

US Patent 6,097,984 to Douglas, which is incorporated herein by reference, describes techniques for directly stimulating the lower esophageal sphincter (LES) of a patient in order to normally maintain it in a

closed state, thereby preventing reflux and treating the symptoms of gastroesophageal reflux disease (GERD). The stimulation is inhibited in response to patient swallowing, by monitoring esophageal motility and timing out an inhibition period following detection of motility representative of swallowing. The system utilizes an implanted stimulator which is programmed to deliver a train of stimulus pulses to one or more electrodes fixed around the gastro-esophageal junction and connected to the stimulator by one or more leads. The motility sensing is performed by a sensor for sensing mechanical wave movement or electrical signals representative of high motility following swallowing. The motility sensor and stimulating electrodes are attached laparoscopically, and are preferably carried by a common stent carrier which is sutured around the lower esophagus.

US Patent 7,310,557 to Maschino, which is incorporated herein by reference, describes a method and apparatus for treatment of an eating disorder including electrically, mechanically and/or pharmaceutically/chemically stimulating the vagus nerve of the lower esophagus, cardia, esophageal/cardia junction, cardia/fundus junction or upper stomach, so as to induce afferent action potentials on the vagus nerve. The device may be noninvasively adjusted after implantation to provide increased or decreased restriction on the patient's gastrointestinal tract. Each stimulus may be administered as a series of programmed pulses of defined amplitude, duration and period, to evoke a responsive signal to the brain by the target nerve, effective for producing a temporary feeling of satiety in the person. An implantable

stimulus generator may be operatively coupled to a nerve electrode, pressure device or chemical outlet to apply a defined signal to a selected nerve branch. The implantable stimulus generator is programmable to allow
5 clinician programming of defined signal parameters effective to treat the eating disorder of the patient. Methods are also provided to identify electrodes nearest to a branch of the vagus nerve to apply an electrical stimulation signal with improved efficiency.

10 US Patent 6,591,137 to Fischell et al., which is incorporated herein by reference, describes techniques for treating gastrointestinal and other disorders via electrical stimulation of plural portions of a patient's gastrointestinal tract. The techniques use an
15 implantable control module, sensors attached to various structures of the gastrointestinal tract, and electrodes also attached to various structures of the gastrointestinal tract. Signals received from the sensors are analyzed to identify events in the
20 gastrointestinal system, and electrical stimulation is applied to structures of the gastrointestinal tract, in sequence, to restore normal function or achieve other clinically desirable results.

US Patent Application Publication 2004/0193229 to
25 Starkebaum et al., which is incorporated herein by reference, describes techniques for treating GERD. Electrical stimulation pulses are generated by an implantable neurostimulator and delivered to a portion of a patient's stomach located downstream from the lower
30 esophageal sphincter via an implantable medical electrical lead. In an embodiment, a motility sensor is fixed in, on or near the stomach or esophagus, and provides a stimulation inhibition or disabling signal

whenever the patient swallows or exhibits esophageal peristalsis.

US Patent 6,678,561 to Forsell, which is incorporated herein by reference, describes a heartburn and reflux disease treatment apparatus including an electric stimulation device adapted to engage the cardia sphincter, and to electrically stimulate the cardia sphincter to increase the sphincter tonus, so that the cardia sphincter completely closes. In an embodiment, the apparatus includes a sensor that senses the contraction wave in the esophagus caused by the patient swallowing food, or a pressure sensor that directly or indirectly senses the pressure in the esophagus.

US Patent 5,833,625 to Essen-Moller, which is incorporated herein by reference, describes an ambulatory system for recording and analyzing gastroesophageal reflux. The system includes a digital recorder, an analysis software package, and a catheter for measurement of changes in esophageal impedance. One embodiment allows for the determination of the direction of flow of the detected material in the esophagus, thus enabling the system to distinguish between swallowed saliva and alkaline gastroesophageal reflux.

US Patent 6,285,897 to Kilcoyne et al., which is incorporated herein by reference, describes an ambulatory system for detecting, recording, and analyzing gastroesophageal reflux or intraesophageal pressure. The system includes an implantable sensor and radiofrequency transmitter, an external receiver and recorder, and an analysis software package. This system provides for monitoring any of various physiological parameters, including pH, temperature, and pressure, within the esophagus or other body lumens.

US Patent 5,938,669 to Klaiber et al., which is incorporated herein by reference, describes an adjustable gastric band for contracting a patient's stomach in order to fight obesity. A gastric band of a known type, implanted around the stomach and including a cavity filled with liquid, is connected by a tube to a control box and a balancing reservoir which are implanted under the patient's skin. The box contains an electric pump and an electronic control unit capable of communicating by radio with a monitor carried by the patient and with a controller intended for the doctor. The controller can operate the pump by remote control to transfer determined volumes of liquid in a closed circuit from the gastric band to the reservoir or vice versa, to adjust the diameter of a passage in the stomach. The monitor receives and signals alarms from the control box.

US Patent 6,454,699 to Forsell, which is incorporated herein by reference, describes a food intake restriction apparatus that includes a restriction device implanted in a patient, which engages the stomach or esophagus to form an upper pouch and a restricted stoma opening in the stomach or esophagus. The restriction device optionally includes at least one implanted sensor for sensing at least one physical parameter of the patient, in which case the control device may control the restriction device in response to signals from the sensor.

US Patent Application Publication 2003/0066536 to Forsell, which is incorporated herein by reference, describes food intake restriction apparatus, including an operable restriction device implanted in a patient and engaging the stomach or esophagus to form a

restricted stoma opening in the stomach or esophagus.
The apparatus includes a source of energy for energizing
the restriction device, and a control device for
releasing energy from the source of energy from outside
5 the patient's body. The released energy is used in
connection with the operation of the restriction device
to vary the size of the stoma opening to allow or
substantially prevent the passage of food therethrough.
The restriction apparatus optionally includes a pressure
10 sensor for directly or indirectly sensing the pressure
in the stomach. The control device may control the
restriction device in response to signals from the
pressure sensor.

The following references, which are incorporated
15 herein by reference, may be of interest:

US Patent 5,188,104 to Wernicke

US Patent Application Publication 2005/0165440 to
Cancel

20 US Patent Application Publication 2006/0116564 to
Mintchev

SUMMARY OF THE INVENTION

In embodiments of the present invention, an eating sensor comprises a ring that is configured to be placed around an esophagus of a subject, typically in a vicinity of a lower esophageal sphincter (LES). The ring comprises a flexible, biocompatible material such as silicone. The ring is typically configured to be secured in place around the esophagus without being surgically coupled to the esophagus or any other tissue of the subject. As a result, implantation is less likely to cause damage to the esophagus or other tissue than techniques which require surgical coupling to the esophagus or other tissue, such as by suturing.

The ring comprises at least one sensor, which is configured to detect passage of food through the esophagus. For some applications, the sensor comprises an optical sensor, an ultrasound transducer, an electromagnetic field sensor, a radiofrequency sensor, a Hall effect sensor, or an impedance sensor. For some applications, the sensor is configured to additionally determine one or more properties of the ingested food, such as solid or liquid content.

There is therefore provided, in accordance with an embodiment of the invention, apparatus including:

a ring configured to be secured around an esophagus of a subject without being surgically coupled to the esophagus or any other tissue of the subject; and

a sensor coupled to the ring, the sensor configured to sense at least one property indicative of passage of food through the esophagus, the property selected from the group consisting of: a property of the esophagus, and a property of the food.

In an embodiment, the sensor is configured to sense the property of the food.

In an embodiment, the sensor is configured to sense the property of the esophagus.

5 In an embodiment, the sensor is configured to sense electrical impedance between two sites of the esophagus.

In an embodiment, the ring is between 50 and 80 Shore A.

10 In an embodiment, the ring includes at least one electrode, which is configured to apply a treatment to the esophagus in response to the sensed property.

In an embodiment, the apparatus includes one or more electrodes that are configured to be applied to a stomach of the subject and to apply a signal to the stomach in response to the sensed property.

In an embodiment, the apparatus includes an adjustable gastric band, configured to change a level of constriction thereof in response to the sensed property.

20 In an embodiment, the ring is configured to be secured around the esophagus in a vicinity of a lower esophageal sphincter (LES) of the subject.

In an embodiment, the ring includes a flexible material.

25 In an embodiment, the ring is shaped to define a slot that is expandable during an implantation procedure to allow placement of the ring around the esophagus.

30 In an embodiment, the ring is flexible and is configured to assume an annular shape by closing the slot, following placement of the ring around the esophagus.

In an embodiment, opposing sides of the slot include a coupling mechanism that is configured to couple the opposing sides of the slot to each other following placement of the ring around the esophagus.

5 In an embodiment, the sensor includes a transmitter and a receiver, which are located along the ring at respective locations such that at least a portion of the esophagus is between the transmitter and the receiver.

In an embodiment, the transmitter includes a source
10 of radiation, and the detector is configured to detect the radiation.

In an embodiment, the transmitter is configured to transmit with a duty cycle of between 0.1 ms/sec and 10 ms/sec.

15 In an embodiment, the apparatus includes a control unit, configured to analyze the detected radiation and to identify the passage of food through the esophagus, in response to analyzing the detected radiation.

In an embodiment, the apparatus includes a control
20 unit, configured to analyze the detected radiation and to identify a property of food passing through the esophagus, in response to analyzing the detected radiation.

In an embodiment, the transmitter is configured to
25 transmit the radiation with a beam angle of between 15 and 45 degrees.

In an embodiment, the transmitter includes at least one transmitter selected from the group consisting of: an infrared transmitter and a visible light transmitter.

30 There is further provided, in accordance with an embodiment of the invention, a method including:

securing a ring around an esophagus of a subject without surgically coupling the ring to the esophagus or any other tissue of the subject; and

sensing, from a vicinity of the ring, at least one property indicative of passage of food through the esophagus, the property selected from the group consisting of: a property of the esophagus, and a property of the food.

The present invention will be more fully understood from the following detailed description of embodiments thereof, taken together with the drawings, in which:

BRIEF DESCRIPTION OF THE DRAWINGS

Fig. 1 is a schematic illustration of a food detection system, in accordance with an embodiment of the present invention;

5 Figs. 2A and 2B are schematic illustrations of a ring of the system of Fig. 1, in accordance with respective embodiments of the present invention;

Figs. 3A and 3B are respective schematic side- and front-view illustrations of a capsule of the system of
10 Fig. 1, in accordance with an embodiment of the present invention; and

Fig. 4 is a schematic illustration of an alternate configuration of the ring of the system of Fig. 1, in accordance with an embodiment of the present invention.

15

DETAILED DESCRIPTION OF EMBODIMENTS

Fig. 1 is a schematic illustration of a food detection system 10, in accordance with an embodiment of the present invention. System 10 comprises a ring 20 and an implantable or external control unit 22, which is coupled to the ring either by one or more leads 24 or wirelessly (wireless configuration not shown). Ring 20 is configured to be placed around an esophagus 26 of a subject 28, typically in a vicinity of a lower esophageal sphincter (LES) 30. Ring 20 typically comprises a flexible, biocompatible material, which is optionally elastic. For example, the material may comprise polyurethane, woven polypropylene, woven nylon, silicone rubber, silk, Teflon® (DuPont), Delrin® (DuPont), or PEEK.

Figs. 2A and 2B are schematic illustrations of ring 20, in accordance with respective embodiments of the present invention. Ring 20 is typically configured to be secured around esophagus 26 without being surgically coupled to esophagus 26 or any other tissue of the subject, i.e., no portion of ring 20 or any surgical coupling elements (such as sutures or staples) penetrate tissue of the esophagus or other tissue in order to couple the ring to the esophagus (although tissue of the subject's body must be penetrated during the implantation procedure in order to insert the ring into the body). In the embodiment shown in Fig. 2A, ring 20 is shaped so as to define a slot 40. During an implantation procedure, the slot is expanded to allow placement of the ring around the esophagus. Once in position around the esophagus, the ring assumes an annular shape, which holds the ring in place around the esophagus.

In the embodiment shown in Fig. 2B, ring 20 comprises a coupling mechanism 32 for coupling the ends of the ring together around the esophagus. For example, the coupling mechanism may be similar to that of a conventional tie wrap, or may comprise one or more sutures, which couple the ends of the ring together without being coupled to the esophagus or other tissue of the subject.

The inner diameter of ring 20 is typically selected for each individual subject, and is generally several millimeters larger than a measured or estimated outer diameter of the subject's esophagus. Typically, the diameter is between about 2.5 and about 5 cm. In embodiments in which the ring comprises silicone rubber, the ring typically has a hardness of between about 50 and about 80 Shore A, such as about 65 Shore A.

Ring 20 comprises at least one sensor 50, and control unit 22 is configured to detect passage of food through the esophagus, and/or properties of such food, responsively to a signal generated by the sensor.

In an embodiment of the present invention, each sensor 50 comprises a transmitter 52 and a detector 54. Typically, transmitter 52 comprises a source of radiation, such as infrared radiation (e.g., having a wavelength of about 880 nm) or visible light (e.g., red light). For example, the source of radiation may comprise one or more LEDs. Detector 54 may comprise, for example, a photodiode or a phototransistor. For some applications, the transmitter transmits with a duty cycle of between about 0.1 ms/sec and about 10 ms/sec, such as about 1 ms/sec, and/or with a beam angle of about 30 degrees +/- 15 degrees. Transmitter 52 and detector 54 are arranged around ring 20 such that the

radiation generated by the source passes through at least a portion of esophagus 26. Control unit 22 analyzes the detected radiation to detect the passage of food through the esophagus, and/or properties of the food.

Alternatively, for some applications, transmitter 52 and detector 54 comprise (a) ultrasound transducers for generating and detecting ultrasound energy, respectively (which, for some applications, are integrated into a single package), (b) an electromagnetic field generator and sensor, respectively (which, for some applications, are integrated into a single package), (c) a radiofrequency generator and sensor, respectively, (d) a Hall effect sensor, and/or (e) an impedance sensor, for sensing conduction of food.

For applications in which the sensor comprises a generator and a detector, the generator and detector are arranged around ring 20 such that the generated energy passes through at least a portion of esophagus 26. For example, the generator and detector may be between about 120 and about 180 degrees apart, e.g., between about 160 and about 180 degrees apart. Control unit 22 analyzes the detected energy to detect the passage of food through the esophagus, and/or properties of the food.

For some applications, ring 20 comprises a plurality of transmitters 52 and/or detectors 54. For example, the plurality of transmitters and detectors may be configured to function in respective transmitter/receiver pairs.

Reference is made to Figs. 3A and 3B, which are respective schematic side- and front-view illustrations of a capsule 70, in accordance with an embodiment of the

present invention. In this embodiment, ring 20 comprises one or more capsules 70, each of which holds one element 72, which element comprises either transmitter 52 or detector 54. Capsule 70 typically
5 comprises a metal can 74, e.g., a titanium can, which is shaped so as to define a window 76, which may be rectangular or generally elliptical, for example. For some applications, the window comprises a sapphire window, which is bonded to can 74. One or more wires 77
10 from leads 24 are coupled to element 72 using one or more feedthroughs 80, as is known in the pacemaker art. Capsule 70 typically further comprises an epoxy cap 78 that stabilizes the leads and seals can 74. Capsule 70 thus is hermetically sealed, which generally results in
15 long life.

For some applications, capsules 70 are embedded in ring 20, as shown in Figs. 2A and 2B. Alternatively, the capsules are coupled to an inner surface of ring 20, as described hereinbelow with reference to Fig. 4.
20 Further alternatively, the capsules are coupled to an outer surface of the ring, in which case the ring is typically shaped so as to define one or more openings therethrough, to provide a transmission path between the transmitter and the receiver (configuration not shown).
25 Still further alternatively, the capsules are coupled to a lower or upper surface of the ring, i.e., above or below the ring with respect to esophagus 26 (configuration not shown).

For some applications, capsule 70 has a length L of
30 between about 4 and about 6 mm, e.g., about 5 mm, a width W of between about 4 and about 6 mm, e.g., about 5 mm, and a depth D of between about 1 and about 3 mm, e.g., about 2 mm.

For some applications, leads 24 comprise between 2 and 4 conductors. Each conductor element may comprise, for example, a drawn-filled tube (DFT) cable or coil, such as a 7x7 or a 1x19 cable. The cable may be
5 insulated with ETFE, silicone, or polyurethane, for example. For some applications, leads 24 are coupled to control unit 22 using IS-1 connectors. For some applications, the conductor comprises a silver core having an MP35N or 35N LT shell.

10 Reference is made to Fig. 4, which is a schematic illustration of an alternate configuration of ring 20, in accordance with an embodiment of the present invention. In this embodiment, capsule 70 is coupled to an inner surface of ring 20. For some applications, a
15 flexible covering 90 covers all or a portion of the inner surface of the ring, and capsule 70 is positioned between the covering and the ring. The covering, or appropriate portions thereof, are typically transparent, to provide a transmission path between the transmitter
20 and the receiver.

In an embodiment of the present invention, control unit 22 is configured to additionally determine at least one property of the food, such as solid or liquid content, based on the signal generated by sensor 50.
25 For some applications, the control unit determines the property by analyzing a parameter of esophagus 26 (such as electrical impedance between two sites of the esophagus) that is indicative of passage of the food. Alternatively or additionally, the control unit directly
30 analyzes a property of the food in order to determine the properties of the food. For example, the control unit may perform spectroscopic analysis of the food based on the signal generated by the sensor.

In an embodiment of the present invention, ring 20 alternatively or additionally comprises at least one treatment element, such as at least one electrode, which is configured to apply a treatment to the esophagus, 5 such as electrical stimulation (configuration not shown). For example, system 10 may be configured to apply an electrical signal to the vicinity of the LES in order to prevent and/or treat gastroesophageal reflux disease (GERD).

10 In an embodiment of the present invention, system 10 is used in conjunction with one or more electrodes that are configured to be applied to a stomach of the subject (configuration not shown). In response to detection of eating using system 10, and/or properties 15 of the ingested food determined using system 10, control unit 22 (or another control unit) drives the electrodes to apply a signal to the stomach, and, for example, configures the signal to enhance satiety of the subject. Alternatively or additionally, in response to detection 20 of eating using system 10, and/or properties of the ingested food determined using system 10, control unit 22 (or another control unit) tightens or loosens an adjustable gastric band that is around the subject's stomach (e.g., by injecting fluid into or withdrawing 25 fluid from a chamber of the gastric band). Typically, these embodiment utilize techniques described in one or more of the co-assigned applications incorporated hereinbelow by reference or in one or more of the references described in the Background section of the 30 present patent application. Typically, food detection system 10 replaces or supplements the impedance- and/or antral sense-based eating sensors in these co-assigned applications.

The scope of the present invention includes embodiments described in the following applications, which are assigned to the assignee of the present application and are incorporated herein by reference.

5 In an embodiment, techniques and apparatus described in one or more of the following applications are combined with techniques and apparatus described herein:

- PCT Patent Application PCT / IL00 / 00132, filed March 5, 2000;
- 10 • PCT Patent Application PCT / IL00 / 00566, filed September 13, 2000;
- US Patent Application 10/237,263, filed September 5, 2002;
- US Patent Application 09/914,889, filed
15 September 4, 2001;
- PCT Patent Application PCT / IL03 / 00736, filed September 4, 2003;
- US Provisional Patent Application 60/259,925, filed January 5, 2001, entitled, "Regulation
20 of eating habits";
- PCT Patent Application PCT / IL02 / 00007, filed January 3, 2002, entitled, "Regulation of eating habits";
- PCT Patent Application PCT / IL04 / 000664,
25 filed entitled, "Gastrointestinal methods and apparatus for use in treating disorders and controlling blood sugar";
- US Patent Application 09/734,358, filed
30 December 21, 2000, entitled, "Acute and chronic electrical signal therapy for

obesity," which issued as US Patent 6,600,953;

- 5 • PCT Patent Application PCT / IL05 / 000904, filed August 18, 2005, entitled, "Monitoring, analysis, and regulation of eating habits";
- US Provisional Patent Application 60/602,550, filed August 18, 2004, entitled, "Monitoring, analysis, and regulation of eating habits";
- 10 • a US provisional patent application to Levi et al., filed January 12, 2006, entitled, "Electrode assemblies, tools, and methods for gastric wall implantation";
- 15 • International Patent Application PCT / IL07 / 000052 to Levi et al., filed January 14, 2007, entitled, "Electrode assemblies, tools, and methods for gastric wall implantation";
- US Provisional Patent Application 60/916,919 to Policker et al., filed May 9, 2007, entitled, "Analysis and regulation of food intake"; and/or
- 20 • International Patent Application PCT/IL2006/000198 to Ben-Haim, filed February 15, 2006, entitled, "Charger with data transfer capabilities."

25 It will be appreciated by persons skilled in the art that the present invention is not limited to what has been particularly shown and described hereinabove. Rather, the scope of the present invention includes both combinations and subcombinations of the various features
30 described hereinabove, as well as variations and modifications thereof that are not in the prior art,

which would occur to persons skilled in the art upon reading the foregoing description.

CLAIMS

1. Apparatus comprising:
 - a ring configured to be secured around an esophagus of a subject without being surgically coupled to the esophagus or any other tissue of the subject; and
 - a sensor coupled to the ring, the sensor configured to sense at least one property indicative of passage of food through the esophagus, the property selected from the group consisting of: a property of the esophagus, and a property of the food.
2. The apparatus according to claim 1, wherein the sensor is configured to sense the property of the food.
3. The apparatus according to claim 1, wherein the sensor is configured to sense the property of the esophagus.
4. The apparatus according to claim 1, wherein the sensor is configured to sense electrical impedance between two sites of the esophagus.
5. The apparatus according to claim 1, wherein the ring is between 50 and 80 Shore A.
6. The apparatus according to claim 1, wherein the ring comprises at least one electrode, which is configured to apply a treatment to the esophagus in response to the sensed property.
7. The apparatus according to claim 1, further comprising one or more electrodes that are configured to be applied to a stomach of the subject and to apply a signal to the stomach in response to the sensed property.
8. The apparatus according to claim 1, further comprising an adjustable gastric band, configured to

change a level of constriction thereof in response to the sensed property.

9. The apparatus according to claim 1, wherein the ring is configured to be secured around the esophagus in a vicinity of a lower esophageal sphincter (LES) of the subject.

10. The apparatus according to claim 1, wherein the ring comprises a flexible material.

11. The apparatus according to any one of claims 1-10, wherein the ring is shaped to define a slot that is expandable during an implantation procedure to allow placement of the ring around the esophagus.

12. The apparatus according to claim 11, wherein the ring is flexible and is configured to assume an annular shape by closing the slot, following placement of the ring around the esophagus.

13. The apparatus according to claim 11, wherein opposing sides of the slot comprise a coupling mechanism that is configured to couple the opposing sides of the slot to each other following placement of the ring around the esophagus.

14. The apparatus according to any one of claims 1-10, wherein the sensor comprises a transmitter and a receiver, which are located along the ring at respective locations such that at least a portion of the esophagus is between the transmitter and the receiver.

15. The apparatus according to claim 14, wherein the transmitter comprises a source of radiation, and the detector is configured to detect the radiation.

16. The apparatus according to claim 15, wherein the transmitter is configured to transmit with a duty cycle of between 0.1 ms/sec and 10 ms/sec.
17. The apparatus according to claim 15, further comprising a control unit, configured to analyze the detected radiation and to identify the passage of food through the esophagus, in response to analyzing the detected radiation.
18. The apparatus according to claim 15, further comprising a control unit, configured to analyze the detected radiation and to identify a property of food passing through the esophagus, in response to analyzing the detected radiation.
19. The apparatus according to claim 15, wherein the transmitter is configured to transmit the radiation with a beam angle of between 15 and 45 degrees.
20. The apparatus according to claim 15, wherein the transmitter comprises at least one transmitter selected from the group consisting of: an infrared transmitter and a visible light transmitter.
21. A method comprising:
securing a ring around an esophagus of a subject without surgically coupling the ring to the esophagus or any other tissue of the subject; and
sensing, from a vicinity of the ring, at least one property indicative of passage of food through the esophagus, the property selected from the group consisting of: a property of the esophagus, and a property of the food.
22. The method according to claim 21, wherein sensing comprises sensing a property of the food.

23. The method according to claim 21, wherein sensing comprises sensing a property of the esophagus.
24. The method according to claim 21, wherein sensing comprises sensing electrical impedance between two sites
5 of the esophagus.
25. The method according to claim 21, further comprising applying a treatment to the esophagus in response to the sensed property.
26. The method according to claim 21, further comprising
10 applying a signal to a stomach of the subject in response to the sensed property.
27. The method according to claim 21, further comprising changing a level of constriction of an adjustable gastric band, in response to the sensed property.
- 15 28. The method according to claim 21, wherein securing the ring comprises securing the ring around the esophagus in a vicinity of a lower esophageal sphincter (LES) of the subject.
29. The method according to any one of claims 21-28,
20 wherein the ring is shaped to define a slot, and wherein securing the ring comprises expanding the slot during an implantation procedure.
30. The method according to claim 29, wherein the ring is flexible, and wherein securing the ring comprises
25 allowing the slot to close and the ring to assume an annular shape, following placement of the ring around the esophagus.
31. The method according to claim 29, wherein securing the ring comprises securing a coupling mechanism that is
30 configured to couple opposing sides of the slot to each other.

other, following placement of the ring around the esophagus.

32. The method according to any one of claims 21-28, wherein sensing comprises transmitting a signal, via the ring, through at least a portion of the esophagus, and receiving the transmitted signal, via the ring, through the portion of the esophagus.

33. The method according to claim 32, wherein transmitting comprises radiating energy.

34. The method according to claim 33, wherein transmitting comprises transmitting with a duty cycle of between 0.1 ms/sec and 10 ms/sec.

35. The method according to claim 33, further comprising analyzing the detected radiation, and identifying the passage of food through the esophagus, in response to analyzing the detected radiation.

36. The method according to claim 33, further comprising analyzing the detected radiation, and identifying a property of food passing through the esophagus, in response to analyzing the detected radiation.

37. The method according to claim 33, wherein transmitting comprises transmitting the radiation with a beam angle of between 15 and 45 degrees.

38. The method according to claim 33, wherein transmitting comprises transmitting at least one form of energy selected from the group consisting of: infrared energy and visible light energy.

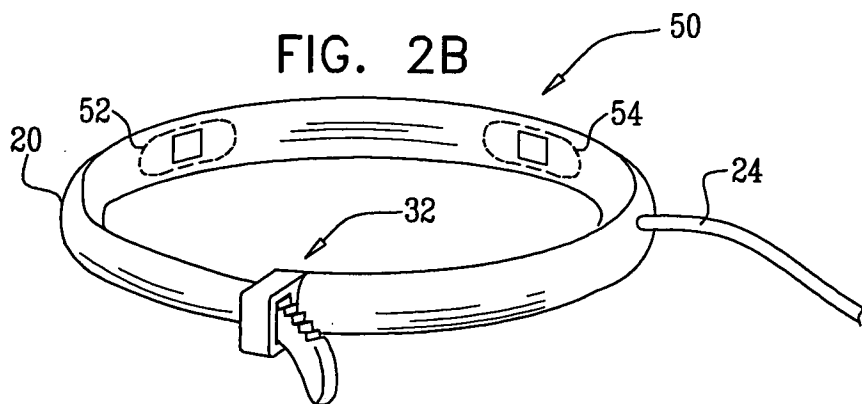
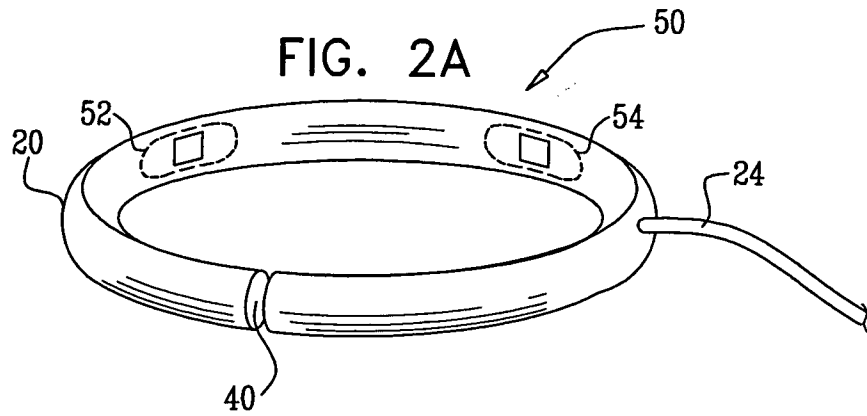
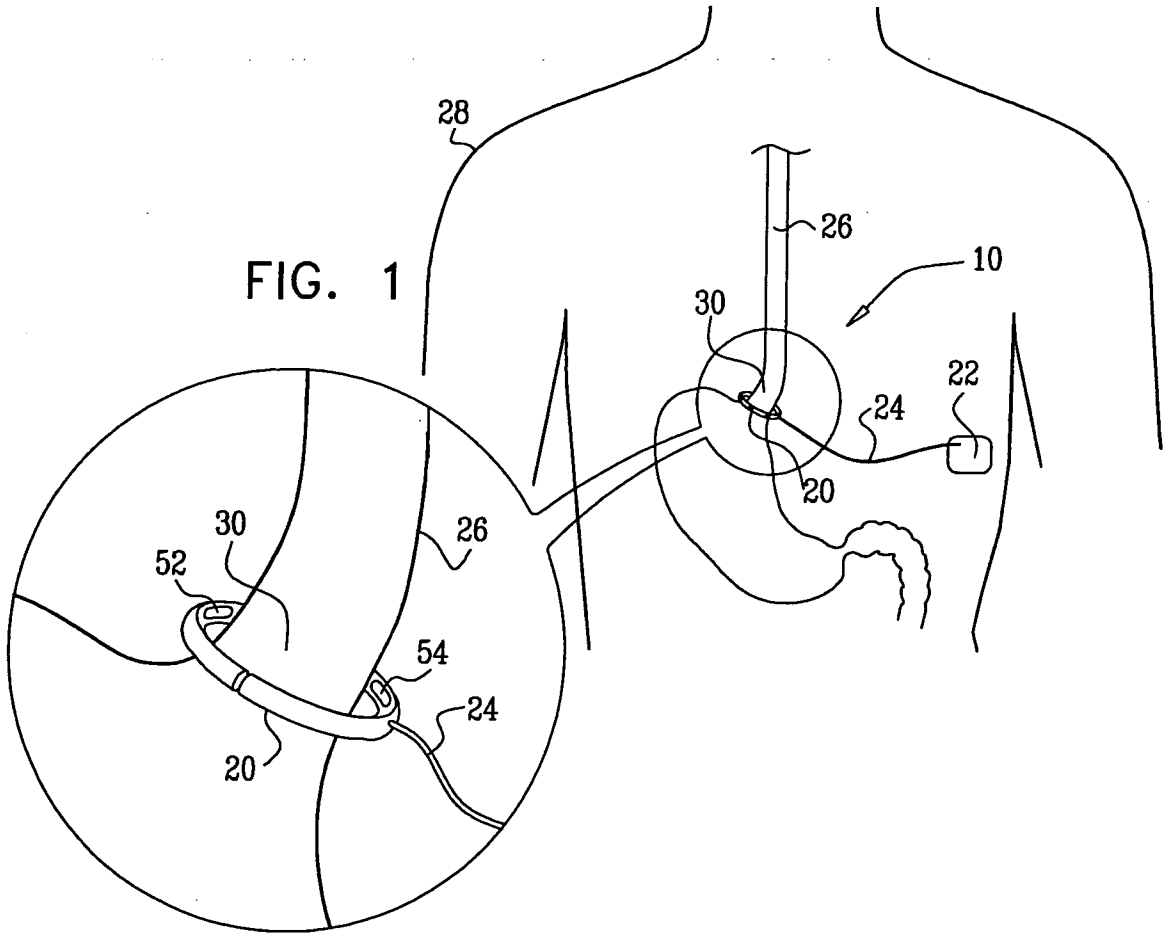

FIG. 3A

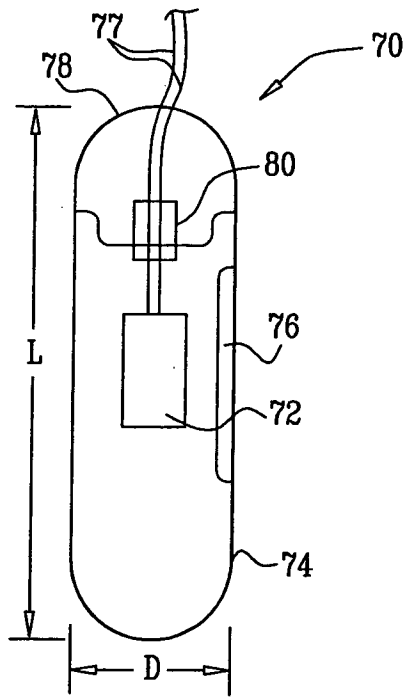

FIG. 3B

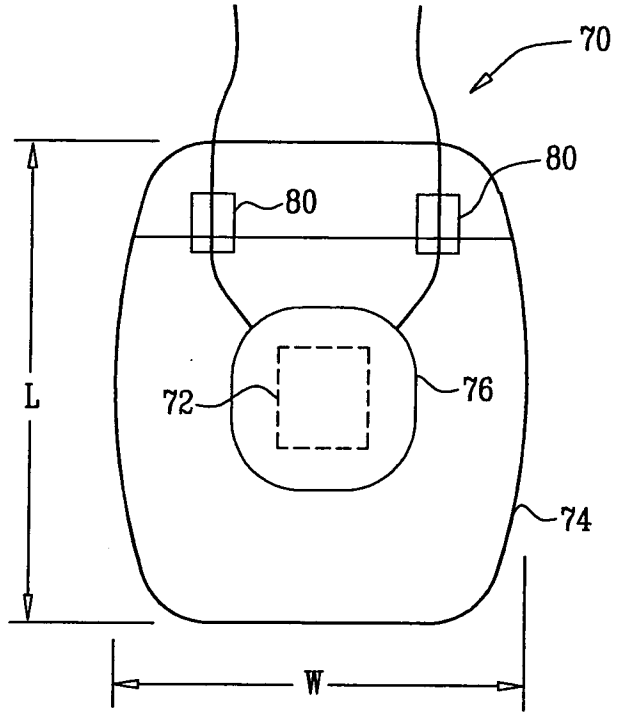
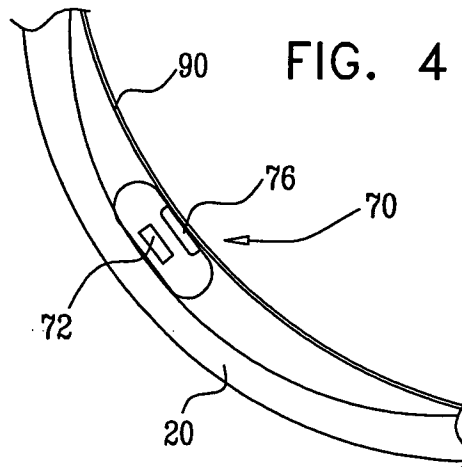

FIG. 4



INTERNATIONAL SEARCH REPORT

International application No

PCT/IL2008/000441

A. CLASSIFICATION OF SUBJECT MATTER INV. A61N1/36 A61B5/00 A61F5/00		
According to International Patent Classification (IPC) or to both national classification and IPC		
B. FIELDS SEARCHED		
Minimum documentation searched (classification system followed by classification symbols) A61B A61F A61N		
Documentation searched other than minimum documentation to the extent that such documents are included in the fields searched		
Electronic data base consulted during the international search (name of data base and, where practical, search terms used) EPO-Internal, WPI Data		
C. DOCUMENTS CONSIDERED TO BE RELEVANT		
Category*	Citation of document, with indication, where appropriate, of the relevant passages	Relevant to claim No.
X	EP 1 004 330 A (MEDTRONIC INC [US]) 31 May 2000 (2000-05-31) paragraph [0015] - paragraph [0017]; figures	1, 3, 4, 6, 10-12
X	US 5 540 730 A (TERRY JR REESE S [US] ET AL) 30 July 1996 (1996-07-30) column 6, line 46 - line 58 column 8, line 18 - line 32	1, 2, 4, 6, 9, 10
X	WO 2006/107901 A (MICARDIA CORP [US]; HILL JAMES [US]; MOADDEB SHAWN [US]) 12 October 2006 (2006-10-12) paragraph [0033] - paragraph [0038]; figures	1, 3, 9-13
Y		7, 8, 14, 15, 17-20
	-/--	
<input checked="" type="checkbox"/> Further documents are listed in the continuation of Box C. <input checked="" type="checkbox"/> See patent family annex.		
* Special categories of cited documents :		
A document defining the general state-of the art which is not considered to be of particular relevance *E* earlier document but published on or after the international filing date *L* document which may throw doubts on priority claim(s) or which is cited to establish the publication date of another citation or other special reason (as specified) *O* document referring to an oral disclosure, use, exhibition or other means *P* document published prior to the international filing date but later than the priority date claimed		*T* later document published after the international filing date or priority date and not in conflict with the application but cited to understand the principle or theory underlying the invention *X* document of particular relevance; the claimed invention cannot be considered novel or cannot be considered to involve an inventive step when the document is taken alone *Y* document of particular relevance; the claimed invention cannot be considered to involve an inventive step when the document is combined with one or more other such documents, such combination being obvious to a person skilled in the art. *&* document member of the same patent family
Date of the actual completion of the international search 1 August 2008		Date of mailing of the international search report 14/08/2008
Name and mailing address of the ISA/ European Patent Office, P.B. 5818 Patentlaan 2 NL - 2280 HV Rijswijk Tel. (+31-70) 340-2040, Tx. 31 651 epo nl, Fax: (+31-70) 340-3016		Authorized officer Strubel, Christine

INTERNATIONAL SEARCH REPORT

International application No

PCT/IL2008/000441

C(Continuation). DOCUMENTS CONSIDERED TO BE RELEVANT

Category*	Citation of document, with indication, where appropriate, of the relevant passages	Relevant to claim No.
Y	US 2006/173238 A1 (STARKEBAUM WARREN L. [US]) 3 August 2006 (2006-08-03) paragraph [0021] - paragraph [0022] paragraph [0026] - paragraph [0027]; figures	8
Y	WO 02/38217 A (NEUROPACE INC [US]) 16 May 2002 (2002-05-16) page 7, line 4 - line 14	7
Y	US 2003/009202 A1 (LEVINE ROBERT A [US]) 9 January 2003 (2003-01-09) paragraph [0080] - paragraph [0083]	14, 15, 17-20

INTERNATIONAL SEARCH REPORT

International application No.
PCT/IL2008/000441

Box No. II Observations where certain claims were found unsearchable (Continuation of item 2 of first sheet)

This international search report has not been established in respect of certain claims under Article 17(2)(a) for the following reasons:

1. Claims Nos.: 21-38
because they relate to subject matter not required to be searched by this Authority, namely:
Rule 39.1(iv) PCT - Method for treatment of the human or animal body by surgery and by therapy
2. Claims Nos.:
because they relate to parts of the international application that do not comply with the prescribed requirements to such an extent that no meaningful international search can be carried out, specifically:
3. Claims Nos.:
because they are dependent claims and are not drafted in accordance with the second and third sentences of Rule 6.4(a).

Box No. III Observations where unity of invention is lacking (Continuation of item 3 of first sheet)

This International Searching Authority found multiple inventions in this international application, as follows:

1. As all required additional search fees were timely paid by the applicant, this international search report covers all searchable claims.
2. As all searchable claims could be searched without effort justifying an additional fee, this Authority did not invite payment of additional fees.
3. As only some of the required additional search fees were timely paid by the applicant, this international search report covers only those claims for which fees were paid, specifically claims Nos.:
4. No required additional search fees were timely paid by the applicant. Consequently, this international search report is restricted to the invention first mentioned in the claims; it is covered by claims Nos.:

Remark on Protest

- The additional search fees were accompanied by the applicant's protest and, where applicable, the payment of a protest fee.
- The additional search fees were accompanied by the applicant's protest but the applicable protest fee was not paid within the time limit specified in the invitation.
- No protest accompanied the payment of additional search fees.

INTERNATIONAL SEARCH REPORT

Information on patent family members

International application No

PCT/IL2008/000441

Patent document cited in search report		Publication date	Patent family member(s)	Publication date
EP 1004330	A	31-05-2000	DE 69922914 D1 DE 69922914 T2 US 6097984 A	03-02-2005 15-12-2005 01-08-2000
US 5540730	A	30-07-1996	NONE	
WO 2006107901	A	12-10-2006	NONE	
US 2006173238	A1	03-08-2006	WO 2006083885 A1	10-08-2006
WO 0238217	A	16-05-2002	CA 2428383 A1 EP 1331967 A2 US 6591137 B1	16-05-2002 06-08-2003 08-07-2003
US 2003009202	A1	09-01-2003	NONE	