

(12) STANDARD PATENT
(19) AUSTRALIAN PATENT OFFICE

(11) Application No. **AU 2008229465 B2**

(54) Title
MRI and RF compatible leads and related methods of operating and fabricating leads

(51) International Patent Classification(s)
A61N 1/16 (2006.01) **A61N 1/37** (2006.01)
A61N 1/05 (2006.01)

(21) Application No: **2008229465** (22) Date of Filing: **2008.03.13**

(87) WIPO No: **WO08/115426**

(30) Priority Data

(31) Number	(32) Date	(33) Country
60/955,724	2007.08.14	US
60/912,835	2007.04.19	US
60/895,619	2007.03.19	US

(43) Publication Date: **2008.09.25**

(44) Accepted Journal Date: **2013.08.22**

(71) Applicant(s)
Boston Scientific Neuromodulation Corporation;Surgi-Vision, Inc.

(72) Inventor(s)
Allen, Justin M.;Edelstein, William A.;Bottomley, Paul A.;Karmarkar, Parag V.

(74) Agent / Attorney
Spruson & Ferguson, L 35 St Martins Tower 31 Market St, Sydney, NSW, 2000

(56) Related Art
WO 2002/042790 A1
US 2004/0064176 A1
WO 2006/119492 A2

(19) World Intellectual Property Organization
International Bureau



(43) International Publication Date
25 September 2008 (25.09.2008)

PCT

(10) International Publication Number
WO 2008/115426 A1

- (51) International Patent Classification:
A61N 1/16 (2006.01) A61N 1/37 (2006.01)
A61N 1/05 (2006.01)
- (21) International Application Number:
PCT/US2008/003420
- (22) International Filing Date: 13 March 2008 (13.03.2008)
- (25) Filing Language: English
- (26) Publication Language: English
- (30) Priority Data:
60/895,619 19 March 2007 (19.03.2007) US
60/912,835 19 April 2007 (19.04.2007) US
60/955,724 14 August 2007 (14.08.2007) US
- (71) Applicant (for all designated States except US): BOSTON SCIENTIFIC NEUROMODULATION CORPORATION [US/US]; 25155 Rye Canyon Loop, Valencia, California 91355 (US).
- (72) Inventors; and
- (75) Inventors/Applicants (for US only): BOTTOMLEY, Paul, A. [US/US]; 6308 Velvet Path, Columbia, Maryland 21044 (US). KARMARKAR, Parag, V. [IN/US]; 7660 Woodpark Lane #401, Columbia, Maryland 21046 (US). ALLEN, Justin, M. [US/US]; Baltimore, Maryland (US). EDELSTEIN, William, A. [US/US]; Baltimore, Maryland (US).
- (74) Agents: RICHARDSON, Julie, H. et al.; Myers Bigel Sibley & Sajovec, P.A., P.O. Box 37428, Raleigh, North Carolina 27627 (US).
- (81) Designated States (unless otherwise indicated, for every kind of national protection available): AE, AG, AL, AM, AO, AT, AU, AZ, BA, BB, BG, BH, BR, BW, BY, BZ, CA, CH, CN, CO, CR, CU, CZ, DE, DK, DM, DO, DZ, EC, EE, EG, ES, FI, GB, GD, GE, GH, GM, GT, HN, HR, HU, ID, IL, IN, IS, JP, KE, KG, KM, KN, KP, KR, KZ, LA, LC, LK, LR, LS, LT, LU, LY, MA, MD, ME, MG, MK, MN, MW, MX, MY, MZ, NA, NG, NI, NO, NZ, OM, PG, PH, PL, PT, RO, RS, RU, SC, SD, SE, SG, SK, SL, SM, SV, SY, TJ, TM, TN, TR, TT, TZ, UA, UG, US, UZ, VC, VN, ZA, ZM, ZW.
- (84) Designated States (unless otherwise indicated, for every kind of regional protection available): ARIPO (BW, GH, GM, KE, LS, MW, MZ, NA, SD, SL, SZ, TZ, UG, ZM, ZW), Eurasian (AM, AZ, BY, KG, KZ, MD, RU, TJ, TM), European (AT, BE, BG, CH, CY, CZ, DE, DK, EE, ES, FI, FR, GB, GR, HR, HU, IE, IS, IT, LT, LU, LV, MC, MT, NL, NO, PL, PT, RO, SE, SI, SK, TR), OAPI (BF, BJ, CF, CG, CI, CM, GA, GN, GQ, GW, ML, MR, NE, SN, TD, TG).

Published:
— with international search report

[Continued on next page]

(54) Title: MRI AND RF COMPATIBLE LEADS AND RELATED METHODS OF OPERATING AND FABRICATING LEADS

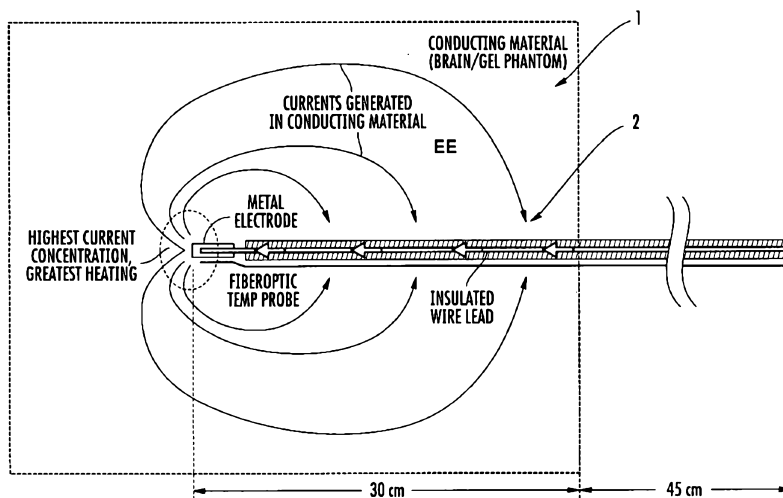

(57) Abstract: RF/MRI compatible leads include at least one conductor that turns back on itself at least twice in a lengthwise direction, and can turn back on itself at least twice at multiple locations along its length. The at least one electrical lead can be configured so that the lead heats local tissue less than about 10 degrees Celsius (typically about 5 degrees Celsius or less) or does not heat local tissue when a patient is exposed to target RF frequencies at a peak input SAR of at least about 4 W/kg and/or a whole body average SAR of at least about 2 W/kg. Related devices and methods of fabricating leads are also described.

WO 2008/115426 A1



-
- *before the expiration of the time limit for amending the claims and to be republished in the event of receipt of amendments*

MRI AND RF COMPATIBLE LEADS AND RELATED METHODS OF OPERATING AND FABRICATING LEADS

RELATED APPLICATIONS

[0001] This application claims the benefit of priority of U.S. Provisional Application Serial No. 60/895,619 filed March 19, 2007, U.S. Provisional Application Serial No. 60/912,835, filed April 19, 2007, and U.S. Provisional Application Serial No. 60/955,724, filed August 14, 2007, the contents of which are hereby incorporated by reference as if recited in full herein.

FIELD OF THE INVENTION

[0002] The present invention relates to conductors and leads and may be particularly suitable for implantable medical leads.

BACKGROUND OF THE INVENTION

[0003] Linear leads comprising conductors can couple with radio frequency (RF) fields, such as those used in magnetic resonance imaging (MRI) and magnetic resonance spectroscopy (MRS). Examples of such leads include guidewires and/or interventional leads such as, for example, implantable pacemaker leads, spinal cord stimulator leads, deep brain stimulator leads, electrophysiology or other cardiac leads, leads used for implanted monitors, and leads used to administer a therapy during a surgical procedure. The coupling can sometimes result in local heating of tissue adjacent the lead(s) due to RF power deposition during the MRI/MRS procedure, potentially leading to undesired tissue damage.

[0004] MRI is a non-invasive imaging modality with excellent soft tissue contrast and functional imaging capabilities. However, MRI can be a contraindication for patients with implanted electrically conducting devices and wires, including cardiac pacemakers and/or defibrillators with leads connecting implantable pulse generators (IPGs), deep brain stimulation (DBS) electrodes, spinal cord stimulators, physiological monitors, etc..., for several reasons. For example, the electronics of the IPG/ICD may fail when in presence of the high magnetic fields, or the RF used in MRI may damage the circuitry of the IPG/ICD. In addition, the implanted lead may couple to local electric fields induced in the body during transmission of RF

excitation pulses whereby the lead can unduly heat tissue adjacent the lead, or may propagate the RF to electrodes at the distal end of the lead or to the device or IPG to which it is connected, potentially causing local temperature rise to unsafe levels and/or damage to the implanted device. The heating problem has been reported in the scientific literature by researchers.

[0005] For example, Luechinger et al. reported a local temperature rise of 20°C in tissue adjacent to pacemaker leads implanted in pigs during an MRI scan. *See, Luechinger et al. In vivo heating of pacemaker leads during magnetic resonance imaging, Eur Heart J 2005; 26(4):376-383.* In addition, Rezai et al. reported *in vitro* tissue heating in excess of 20°C adjacent to DBS (deep brain stimulation) leads during an MRI scan. Rezai et al., *Is magnetic resonance imaging safe for patients with neurostimulation systems used for deep brain stimulation? Neurosurgery 2005;57(5):1056-1062.* Even external leads such as those used for measuring and monitoring physiological signals (electrocardiograms, EKG, electroencephalograms, blood pressure, sonography) during MRI may be subject to heating.

[0006] One approach to allow patients with implanted devices, such as IPGs and leads to be scanned by MRI, is the use of strictly controlled conditions that limits the input power of the MRI RF pulse sequences. This approach is reported by Gimbel et al., *strategies for the safe magnetic resonance imaging of pacemaker-dependent patients, Pacing Clin Electrophysiol 2005;28(10):1041-1046,* and Roguin et al., *Modern pacemaker and implantable cardioverter/defibrillator systems can be magnetic resonance imaging safe: in vitro and in vivo assessment of safety and function at 1.5 T. Circulation 2004; 110(5):475-482.*

[0007] In other (non-MRI) uses of RF, such as where external RF electromagnetic (EM) energy is present and/or used for therapeutic purposes, external or implanted leads may also couple to the applied RF EM field and cause unsafe tissue heating or damage or destroy electronic devices that can be connected thereto. For example, RF diathermy or ablation or cauterization of tissue can sometimes employ implanted or intra-body leads that may also couple to the applied RF EM field and cause unsafe tissue heating, such as that reported for a patient undergoing RF diathermy. *See, Nutt et al., DBS and diathermy induces severe CNS damage, Neurology 2001;56:1384-1386; and Ruggera et al., In Vitro assessment of tissue heating near metallic medical implants by exposure to pulsed radio frequency*

diathermy, *Physics in Medicine and Biology*, 48 (2003) 2919-2928. Another non-MRJ example of where such EM-field coupling may occur is where individuals with implanted leads are in close proximity to EM field transmitters such as RADAR, TV, wireless telephone, radio facilities, fixed or mobile. Similarly, EM-coupling may also occur with external-conducting leads connecting electronic equipment that are sensitive to intense EM fields close to intense EM field sources.

Summary of Embodiments of the Invention

[0008] An aspect of the present invention provides an RF/MRI compatible medical device comprising:

an elongate medical lead comprising at least one conductor with opposing proximal and distal portions, the at least one conductor comprising a plurality of preformed current suppression modules, each current suppression module comprising

a first forward section that extends in an axially forward direction for a first physical length then turns back to define a second reverse section that extends in a substantially opposing axial direction for a second physical length, then turns again to define a third forward section that extends in the axially forward direction for a third physical length, wherein the second reverse section comprises a coiled segment having a plurality of wound coils, wherein each current suppression module is configured and arranged to substantially suppress current induced by RF utilized during an MRI procedure.

[0008a] Another aspect of the present invention provides a method of fabricating a medical lead, comprising:

providing a length of at least one elongate conductor; and

forming a plurality of preformed current suppression modules in each conductor by turning the at least one conductor back on itself at least twice to define two forward portions that extend lengthwise in an axially forward direction and at least one rearward portion, between the two forward portions, that travels in a substantially opposing rearward direction, wherein the rearward portion comprises a coiled segment having a plurality of wound coils, wherein each current suppression module is configured and arranged to substantially suppress current induced by RF utilized during an MRI procedure.

[0008b] Embodiments of the present invention are directed to RF/MRI compatible leads and/or conductors. The leads and/or conductors are configured to inhibit, limit and/or prevent undesired

heating of local tissue and/or the propagation of RF to an attached electronic device by the leads when exposed to certain levels of RF. Particular embodiments of the present invention are directed to flexible implantable leads with one or multiple conductors that can be safely used in an external RF field, such as those used for MRI or MRS. The configuration of the conductor(s) can reduce unwanted coupling to RF-induced electric fields generated in the body and may reduce, minimize and/or inhibit common mode current/voltage. The leads can be configured so that RF power deposition from the leads to adjacent tissue is reduced, permitting patients implanted with such leads, to benefit from MRI/MRS under safer conditions and/or permitting the use of elongate leads, cables and the like to be used in magnet bores associated with MR Scanners during MRI procedures.

[0009] Some embodiments are directed to RF/MRI compatible medical devices that include an elongate electrical medical lead having at least one conductor with opposing proximal and distal portions. The at least one conductor turns back on itself at least twice so that it has a first section that extends in a first lengthwise direction for a first physical length, then turns to define at least one reverse section that extends in a substantially opposing lengthwise direction for a second physical length, then turns again to define a third section that extends in the first lengthwise direction for a third physical length. The first, second and third physical lengths can be a minor sub-portion of an overall length of the at least one conductor, and may include a plurality of sets of turns. In other embodiments, the conductor can be configured with a single set of longer turns forming the first, second and third lengths may occupy substantially the entire length of the conductor.

[0010] The at least one electrical lead may be configured so that the lead heats local tissue less than about 10 degrees Celsius (typically about 5 degrees Celsius or less) or does not heat local tissue when a patient is exposed to target RF frequencies at an input peak SAR of at least about 4 W/kg and/or whole body average SAR of about 2 W/kg.

[0011] In some embodiments, the electrical lead heats local tissue less than about 2 degrees Celsius when exposed to target RF frequencies associated with MR Scanners at a peak input SAR of about 4 W/kg and/or whole body average SAR of about 2 W/kg. In particular embodiments, the electrical lead can be configured to heat local tissue less than about 5 degrees Celsius when exposed to target RF frequencies associated with MR Scanners generating a peak input SAR of between about 4-10 W/kg and/or a whole body average SAR of between about 2-5 W/kg.

[0012] Other embodiments are directed to MRI/RF compatible medical lead systems. The lead systems include a lead comprising at least one conductor. Each of the at least one conductors is configured with a plurality of (RF-induced) current suppression modules. The lead systems also include at least one electrode in communication with the at least one conductor.

[0013] The medical lead system may be configured so that the reverse segment has a physical length that is shorter than that of the forward segment, and wherein the forward and reverse segments have an electrical length that is about $\lambda/4$ or less of an electromagnetic wavelength of interest of the at least one conductor in a target body.

[0014] The lead system may be configured to heat local tissue less than about 10 degrees Celsius (typically about 5 degrees Celsius or less) when exposed to RF associated with an MRI Scanner at a peak input SAR of between about 4 W/kg to about 10 W/kg and/or a whole body average SAR of between about 2 W/kg to about 5 W/kg.

[0015] Yet other embodiments are directed to medical leads that include: (a) at least one electrode; and (b) a lead with at least one conductor in communication with the at least one electrode. The at least one conductor has a first forward portion that extends in a lengthwise forward direction for a first physical distance toward the at least one electrode, then turns back at least once to define at least one rearward portion that travels in a substantially opposing lengthwise rearward direction for a

second physical distance, then turns back again to define a second forward portion that extends in the forward direction a third physical distance with a distal portion of the second forward portion residing beyond and downstream of the first forward portion.

[0016] In some embodiments, the second physical distance being less than the first and/or third physical distance. The first forward and first rearward portions can have a substantially equal electrical length when exposed to RF frequencies associated with an MRI Scanner.

[0017] Still other embodiments are directed to medical leads with at least one conductor having spaced apart current suppression modules. At least one of the current suppression modules comprising a length of conductor having a plurality of closely spaced conductor portions in a serpentine shape.

[0018] The serpentine shaped closely spaced conductor portions can include conductor segments that extend in a lengthwise direction with bend portions therebetween that reside substantially within a substantially common localized lengthwise extending region of the lead.

[0019] Additional embodiments are directed to MRI/RF safe lead systems that include: (a) an elongate flexible lead with a plurality of conductors having a length with opposing proximal and distal end portions, the conductors each having a plurality of current suppression modules extending along the length of the conductor, each current suppression module comprising at least one coiled segment; and (b) a plurality of electrodes, one or more of the conductors in communication with a respective one of the electrodes.

[0020] The lead system may be configured to inhibit undesired temperature rise in local tissue to less than about 10 degrees Celsius (typically about 5 degrees Celsius or less) when exposed to RF frequencies associated with the MRI scanner at a peak SAR input of between about 4 W/kg to at least about 10W/kg and/or at a whole body average SAR of between about 2 W/kg to at least about 5 W/kg.

[0021] The lead system may be configured with corresponding pairs of the forward and rearward portions having substantially the same electrical length, and with the forward portions have a lengthwise physical length of between about 2-50 cm, and wherein the rearward portions have a lengthwise physical length of between about 1-25 cm.

[0022] Yet other embodiments are directed to implantable flexible leads that have a plurality of conductors extending between opposing proximal and distal end portions of the lead. One or more of the conductors is connected to at least one or a plurality of electrodes at the distal end portion thereof and at least some of the plurality of conductors are configured with at least one coiled conductor portion and at least one closely spaced serpentine shaped conductor portion.

[0023] The implantable flexible lead system may be configured so that at least one of the conductors is configured so that at least some of the serpentine shaped portion resides inside the coiled portion of the respective conductor.

[0024] Some embodiments are directed to an implantable flexible lead that includes at least first and second conductors extending between opposing proximal and distal end portions of the lead. One or more of the conductors is connected to at least one of a plurality of electrodes at the distal end portion thereof. The first and second conductors include a substantially straight portion and a coiled portion. The straight portion of the first conductor extends in a lengthwise direction outside and proximate to the second conductor coiled portion or inside and through the second conductor coiled portion.

[0025] Yet other embodiments are directed to methods of fabricating a medical lead. The methods include: (a) providing a length of at least one elongate conductor; and (b) turning the at least one conductor back on itself at least twice to define two forward portions that extend lengthwise in a forward direction and at least one rearward portion that travels in substantially opposing rearward direction for a second lengthwise physical distance.

[0026] The methods may optionally also include, after the turning step, forming a flexible implantable lead body and sterilizing and packaging the implantable lead body.

[0027] Still other embodiments are directed to lead systems with an elongate electrical conductor adapted to reside in a patient with a first forward extending segment having a corresponding first electrical and physical length and a second reversed segment of the electrical conductor in close proximity to the first segment and extending in a substantially opposing lengthwise direction from the first forward segment. The second reversed segment has substantially the same or a shorter physical length than the first forward segment with substantially the same, less

or greater electrical length as the first forward segment when exposed to RF in the range of between about 1 MHz to at least about 200 MHz.

[0028] Additional embodiments are directed to methods of inhibiting heating local tissue and/or suppressing or offsetting common mode RF currents in an electrical lead configured to reside in a patient, the electrical lead comprising at least one conductor having a first forward section with a first physical forward length and at least one reversed section extending in a substantially opposing lengthwise direction from the first forward section, the at least one reversed section has a second physical reverse length that is shorter than that of the first forward section and with an electrical length that is substantially the same or greater than that of the first forward section. The method includes: (a) generating RF induced common mode current in the first forward section and the at least one reversed section of the electrical conductor, whereby common mode current flows in the first forward section and the reversed section in substantially the same direction; and (b) offsetting the current in the first forward section and the reversed section at a localized region of the conductor between the first forward and the reversed section.

[0029] The method may include placing the patient in an MRI scanner to carry out the generating step, then transmitting an electrical output to local tissue via an electrode in communication with the at least one conductor first forward and reverse sections thereby inhibiting the electrode from unduly heating local tissue whereby the first forward and reverse sections suppress common mode current propagated to the electrode by the electrical lead.

[0030] Yet other embodiments are directed to lead systems adapted to connect two electronic devices and provide substantial immunity to signals induced by virtue of proximity to an electromagnetic radiation source. The lead systems include at least one elongate conductor having a first elongate forward section that extends in a forward lengthwise direction for a first forward physical length, then turns to define at least one reverse section that extends in a substantially opposing reverse lengthwise direction for a reverse physical length, then turns again to define another forward physical length. The at least one conductor is configured to be substantially immune (inhibit or not propagate) to RF induced current and/or common mode signals induced by proximity to an electromagnetic radiation source.

[0031] Yet other embodiments are directed to an RF compatible medical lead that includes at least one continuous length of conductor having at least one segment with the lead configured to turn back on itself at least twice in a lengthwise direction.

[0032] Still other embodiments are directed to a conductive medical cable with at least one conductor configured for use in an MR Scanner bore, the conductor configured to turn back on itself at least twice in a lengthwise direction to define an RF-induced heat resistant cable.

[0033] Other systems, devices, and/or methods according to embodiments of the invention will be or become apparent to one with skill in the art upon review of the following drawings and detailed description. Features or components described with respect to one embodiment are not limited to that embodiment and may be implemented into other embodiments. It is intended that all such additional systems, methods, and/or computer program products be included within this description, be within the scope of the present invention, and be protected by the accompanying claims.

BRIEF DESCRIPTION OF THE DRAWINGS

[0034] These and other features of the present invention will be more readily understood from the following detailed description of exemplary embodiments thereof when read in conjunction with the accompanying drawings, in which:

[0035] **Figure 1** is a schematic illustration of a phantom with a linear insulated wire lead and electrode.

[0036] **Figure 2** is a graph of time (sec) versus temperature (C) at the electrode shown in **Figure 1** based on a 4.5 W/kg peak input SAR MRI scan.

[0037] **Figure 3** is a schematic illustration of three different conductor configurations according to embodiments of the present invention.

[0038] **Figure 4** is a schematic illustration of two different lead configurations according to embodiments of the present invention.

[0039] **Figure 5** is a schematic illustration of a single conductor having a forward and reverse segment according to embodiments of the present invention.

[0040] **Figure 6A** is a schematic illustration of a single conductor having forward and reverse segments that may be capacitively coupled according to embodiments of the present invention.

[0041] **Figures 6B-6E** are schematic illustrations of a conductor with a current suppression module of forward and reverse segments and exemplary capacitance configurations according to embodiments of the present invention.

[0042] **Figure 7** is a schematic illustration of a lead with a conductor and electrode, with the conductor having a plurality of forward and reverse segments spaced apart in a lengthwise direction according to embodiments of the present invention.

[0043] **Figures 8A-8C** are graphs of temperature Celsius (C) change versus time (seconds) for different lead/conductor configurations (**Figure 8C** is a control wire) according to embodiments of the present invention.

[0044] **Figure 9** is a schematic illustration of a lead with multiple closely spaced conductors, the conductors having reverse and forward segments according to embodiments of the invention.

[0045] **Figure 10** is a schematic illustration of the lead shown in **Figure 9** illustrating that the lead may also include capacitive coupling between the reverse segment and one or more of the forward segments according to embodiments of the present invention.

[0046] **Figure 11** is a schematic illustration of a lead with multiple conductors and multiple sensors and/or electrodes and multiple reverse and forward segments according to embodiments of the present invention.

[0047] **Figures 12A** is a digital photograph of a prototype flexible lead according to embodiments of the present invention.

[0048] **Figure 12B** is a partial view of the prototype shown in **Figure 12A** with the end of the lead shown straight with respect to a ruler.

[0049] **Figures 12C-12D** are enlarged images of a portion of the lead shown in **Figure 12B**.

[0050] **Figures 13A** and **13B** are graphs of temperature change (C) over time (seconds) for four electrode and four conductor lead systems according to embodiments of the present invention.

[0051] **Figures 14A-14M** are schematic illustrations of conductor configurations according to embodiments of the present invention.

[0052] **Figures 15A and 16** are graphs of impedance (Ohms) versus frequency (MHz) for some exemplary leads measured in saline according to some embodiments of the present invention ("CBS" in **Figure 16** means "coiled backward section" and "CSM" means current suppression module).

[0053] **Figure 15B** is a schematic of a measurement probe attachment configuration that can be used to measure impedance such as the results shown in **Figure 15A** according to some embodiments of the present invention.

[0054] **Figures 17 and 18** are graphs of temperature change (C) versus time (seconds) of exemplary leads in an MRI Scanner for a 1.5T MRI scanner and a 3.0T MRI scanner, respectively.

[0055] **Figures 19 and 20** are graphs of impedance (Ohms) versus frequency (MHz) of leads measured in various materials (saline, gel).

[0056] **Figure 21A** is a schematic illustration of a single conductor with a multi-layer stacked coil configuration (tri-layer) of two forward segments connected by one reverse segment according to embodiments of the present invention.

[0057] **Figures 21B and 21C** are side views of stacked tri-layer conductor configurations. **Figure 21B** illustrates a single conductor configuration and **Figure 21C** illustrates two co-wound conductors according to embodiments of the present invention.

[0058] **Figure 21D** is a partial side view of a proximal (or distal) end portion of a lead according to embodiments of the present invention.

[0059] **Figure 22A** is a schematic illustration of a single conductor with a multi-layer stacked coil configuration (two-layer) of two forward segments connected by one reverse segment according to embodiments of the present invention.

[0060] **Figures 22B and 22C** are side views of a two-layer stacked conductor configurations. **Figure 22B** illustrates a single conductor two-layer stacked configuration and **Figure 22C** illustrates two co-wound conductors with a two-layer stacked configuration according to embodiments of the present invention.

[0061] **Figure 22D** is a side view of a two-layer stacked two-conductor CSM lead configuration according to embodiments of the present invention.

[0062] **Figure 22E** is a side view of the device shown in **Figure 22D** with the addition of a sleeve placed over the CSM according to embodiments of the present invention.

[0063] **Figure 22F** is a partial exploded view of the device shown in **Figure 22E** illustrating a winding-direction transition zone where the lead goes from CW to CCW (or the reverse) according to embodiments of the present invention.

[0064] **Figure 23** is a schematic illustration of a lead with a conductor having multiple spaced apart segments of the multi-layered coils connected to an electrode according to embodiments of the present invention.

[0065] **Figure 24A** is a graph of impedance (Ohms) versus frequency (MHz) of a lead having a plurality of spaced apart (in the lengthwise direction) three layer current suppression modules (CSM) described in **Figure 21A**.

[0066] **Figure 24B** is a digital photograph of an exemplary method to measure impedance of a current suppression module of a multi-conductor configuration according to some embodiments of the present invention.

[0067] **Figures 25A** and **25B** are graphs of temperature change (C) versus time (seconds) of a 61 cm lead with two conductors and with two electrodes, each conductor having three-layer current suppression modules (about 12 current suppression modules along its length) configured as described in **Figure 21A**. **Figure 25A** corresponds to the lead with the tri-layer CSM configuration and two electrodes in a gel phantom for the RF pulse sequence generating a peak input SAR of 4.3W/kg in a 3T MR Scanner. **Figure 25B** corresponds to the lead in gel phantom in a 1.5T MR Scanner at a peak SAR of 4.3W/Kg.

[0068] **Figure 26** is a graph of impedance (Ohms) versus frequency (MHz) of a lead having spaced apart (in the lengthwise direction) two layer current suppression modules (CSMs) configured as described in **Figure 22A**.

[0069] **Figure 27** is a graph of temperature change (C) versus time (seconds) of a lead of about 61 cm with two conductors, each having about 12 two-layer stacked CSM segments having a length of about 5.7 cm. The temperature/time data was obtained for the lead in gel phantom in a 1.5T MR Scanner at an SAR of the pulse sequence of 4.3W/Kg.

[0070] **Figures 28A** and **28B** are schematic side sectional views of a conductor with multi-layer coiled CSM configurations. **Figure 28A** corresponds to

the first layer of the single conductor of a two-layer (double stack) configuration such as that shown in **Figure 22A**. **Figure 28B** corresponds to the three separate conductor layers of a three-layer configuration such as shown in **Figure 21A**.

[0071] **Figures 29A and 29B** are greatly enlarged digital photographs of a portion of a two conductor lead having a stacked (three layer) CSM configuration according to embodiments of the present invention. **Figure 29B** also illustrates an outer layer on the lead to provide a substantially constant outer diameter lead according to embodiments of the present invention.

[0072] **Figures 29C and 29D** are greatly enlarged digital photographs of a portion of a two conductor lead having a stacked (two layer) CSM configuration. **Figure 29D** also illustrates an outer layer on the lead to provide a substantially constant outer diameter lead according to embodiments of the present invention.

[0073] **Figure 30A** is a schematic illustration of a DBS system with at least one lead, IPG and electrodes according to some embodiments of the present invention (the DBS system includes two leads and two IPGs).

[0074] **Figures 30B and 30C** are schematic illustrations of therapeutic systems with leads in communication with a cardiac pulse generator. **Figure 30B** illustrates the system can include two leads, extending to the RA and RV, respectively, while **Figure 30C** illustrates that the cardiac system can have three leads (one each in the RV, RA and LV).

[0075] **Figure 30D** is a schematic illustration of a lead that connects two internal or external devices according to embodiments of the present invention.

[0076] **Figures 30E-30G** are schematic illustrations of cables that extend within a bore of an MR Scanner can be configured with the current suppression modules according to embodiments of the present invention.

[0077] **Figures 31A, 31B, 32A and 32B** are schematic illustrations of leads which may be particularly suitable for bradyarrhythmia and tachyarrhythmia lead systems according to embodiments of the present invention.

[0078] **Figure 33** is a schematic illustration of a multi-conductor lead configurations according to some embodiments of the present invention.

[0079] **Figures 34 and 35** are schematic illustrations of multi-conductor leads with each conductor having multiple current suppression modules according to some embodiments of the present invention.

[0080] **Figure 36** is a schematic illustration of yet another lead configuration with stacked reverse and forward segments of adjacent lengths of a single conductor forming a respective current suppression module and with an RF trap shield layer according to embodiments of the present invention.

[0081] **Figure 37** is a schematic illustration of a lead with at least one inner conductor configured to rotate substantially freely with respect to the lead body according to embodiments of the present invention.

[0082] **Figure 38** is a schematic illustration of a lead similar to that shown in **Figure 37** but with the proximal electrode conductor comprising an RF trap(s) along the length of the lead according to some embodiments of the present invention.

[0083] **Figure 39** is a schematic illustration of a lead comprising three conductors with some cowound with others to form at least some current suppression modules for respective conductors according to some embodiments of the present invention.

[0084] **Figure 40** is a schematic illustration of a lead with multiple conductors having multiple respective current suppression modules spaced apart along the length of the lead according to some embodiments of the invention.

[0085] **Figure 41** is a schematic illustration of yet another lead configuration with multiple conductors, each having current suppression modules, with a distal electrode conductor being substantially concentric to and/or inside the shock/stimulation electrode conductors according to some embodiments of the present invention.

[0086] **Figure 42** is a schematic illustration of another lead configuration where the distal electrode conductor comprises current suppression modules but one or more of the other conductors may be substantially straight according to embodiments of the present invention. As shown, the lead may be particularly suitable as a passive fixation tachyarrhythmia lead.

[0087] **Figure 43** is a schematic illustration similar to **Figure 42**, but with the end configured as an active fixation end according to embodiments of the present invention. This configuration may be particularly suitable as an active fixation tachyarrhythmia lead.

[0088] **Figure 44** is a schematic illustration of another lead configuration with multiple conductors where each conductor includes current suppression modules

spaced apart along its length according to embodiments of the present invention. This lead configuration may be particularly suitable as an active fixation tachyarrhythmia lead.

[0089] **Figures 45A-E** are images of a winding sequence for fabricating a tri-layer current suppression module using a coil winder (shown with two cowound conductors) according to some embodiments of the present invention.

[0090] **Figures 46A-46F** are images of a winding sequence for fabricating a two layer current suppression module using a coil winder according to some embodiments of the present invention.

[0091] **Figures 47A-47C** are digital photographs of a subassembly of a lead with conductor having wound/stacked current suppression modules according to embodiments of the present invention.

[0092] **Figures 48A-48D** are digital images of a mold used to form the flexible lead body of the wound conductor(s) shown in **Figures 47A-47C** according to embodiments of the present invention.

[0093] **Figure 49** is a digital image of a flexible lead with an overmolded outer layer and the wound conductor(s) according to embodiments of the present invention.

[0094] **Figure 50** is a schematic illustration of an exemplary (and optional) mold with a wound conductor subassembly therein according to embodiments of the present invention.

[0095] **Figure 51** is an end view of the subassembly and mold shown in **Figure 50**.

[0096] **Figure 52** is a cutaway side view of the subassembly and mold shown in **Figure 50**.

[0097] **Figure 53** is a flow chart of operations that can be used to fabricate a lead according to embodiments of the present invention.

[0098] **Figure 54A** is a perspective view of an example of a test fixture used to assess fatigue resistance of some lead embodiments of the present invention.

[0099] **Figure 54B** is a top view of the test fixture shown in **Figure 54A**.

[0100] **Figure 54C** is a digital photograph of a test fixture according to embodiments of the present invention.

[0101] **Figure 55A** is a side view of a portion of a lead that may be suitable to be a passive fixation pacemaker lead according to embodiments of the present invention.

[0102] **Figure 55B** is a side perspective view of the lead shown in **Figure 55A**.

[0103] **Figure 56A** is a side view of a portion of a lead that may be suitable to be a passive fixation ICD lead according to embodiments of the present invention.

[0104] **Figure 56B** is a side perspective view of the lead shown in **Figure 56A**.

[0105] **Figure 57A** is a side view of a portion of a lead that may be suitable to be an active fixation pacemaker lead according to embodiments of the present invention.

[0106] **Figure 57B** is a side perspective view of the lead shown in **Figure 57A**.

[0107] **Figure 58A** is a side view of a portion of a lead that may be suitable to be an active fixation ICD lead according to embodiments of the present invention.

[0108] **Figure 58B** is a side perspective view of the lead shown in **Figure 58A**.

[0109] **Figure 59** is a flow chart of exemplary operations that can be used to form leads with MCSMs according to embodiments of the present invention.

DETAILED DESCRIPTION OF EMBODIMENTS OF THE INVENTION

[0110] The present invention will now be described more fully hereinafter with reference to the accompanying drawings, in which embodiments of the invention are shown. This invention may, however, be embodied in many different forms and should not be construed as limited to the embodiments set forth herein; rather, these embodiments are provided so that this disclosure will be thorough and complete, and will fully convey the scope of the invention to those skilled in the art. Like numbers refer to like elements throughout. It will be appreciated that although discussed with respect to a certain embodiment, features or operation can apply to others.

[0111] In the drawings, the thickness of lines, layers, features, components and/or regions may be exaggerated for clarity and broken lines illustrate optional features or operations, unless specified otherwise. In addition, the sequence of operations (or steps) is not limited to the order presented in the claims unless specifically indicated otherwise. It will be understood that when a feature, such as a layer, region or substrate, is referred to as being "on" another feature or element, it can be directly on the other element or intervening elements may also be present. In contrast, when an element is referred to as being "directly on" another feature or element, there are no intervening elements present. It will also be understood that, when a feature or element is referred to as being "connected" or "coupled" to another feature or element, it can be directly connected to the other element or intervening elements may be present. In contrast, when a feature or element is referred to as being "directly connected" or "directly coupled" to another element, there are no intervening elements present. Although described or shown with respect to one embodiment, the features so described or shown can apply to other embodiments.

[0112] Unless otherwise defined, all terms (including technical and scientific terms) used herein have the same meaning as commonly understood by one of ordinary skill in the art to which this invention belongs. It will be further understood that terms, such as those defined in commonly used dictionaries, should be interpreted as having a meaning that is consistent with their meaning in the context of the relevant art and this specification and should not be interpreted in an idealized or overly formal sense unless expressly so defined herein.

[0113] The terminology used herein is for the purpose of describing particular embodiments only and is not intended to be limiting of the invention. As used herein, the singular forms "a", "an" and "the" are intended to include the plural forms as well, unless the context clearly indicates otherwise. It will be further understood that the terms "comprises" and/or "comprising," when used in this specification, specify the presence of stated features, integers, steps, operations, elements, and/or components, but do not preclude the presence or addition of one or more other features, integers, steps, operations, elements, components, and/or groups thereof. As used herein, the term "and/or" includes any and all combinations of one or more of the associated listed items. As used herein, phrases such as "between X and Y" and "between about X and Y" should be interpreted to include X and Y. As

used herein, phrases such as "between about X and Y" mean "between about X and about Y." As used herein, phrases such as "from about X to Y" mean "from about X to about Y."

[0114] The term "lead" refers to an elongate assembly that includes one or more conductors. The lead typically connects two spaced apart components, such as, for example, a power source and/or input at one end portion and an electrode and/or sensor at another position, such as at a distal end portion or electrodes at both end portions. The lead is typically flexible. The lead can be substantially tubular with a cylindrical shape, although other shapes may be used. The lead can have a solid or hollow body and may optionally include one or more lumens. In particular embodiments, a lead can be a relatively long implantable lead having a physical length of greater than about 10 cm (up to, for example, 1 m or even longer). The term "physical length" refers to a length that can be measured in units of length or distance, *e.g.*, millimeters, inches and the like, and is typically constant and does not vary when exposed to different electromagnetic fields (unlike electrical wavelengths), recognizing that a physical length may shrink or expand when exposed to low or high temperatures. The lead can include at least one electrode, and in some embodiments, a plurality of electrodes (which may be both on proximal and distal end portions), and in some particular embodiments, at least one electrode can be a recording or sensing electrode or both a recording and stimulating and/or ablating electrode.

[0115] The term "conductor" and derivatives thereof refer to a conductive trace, filar, wire, cable, flex circuit or other electrically conductive member. A conductor may also be configured as a closely spaced bundle of filars or wires. The conductor can be a single continuous length. The conductor can be formed with one or more of discrete filars, wires, cables, flex circuits, bifilars, quadrafilars or other filar or trace configuration, or by plating, etching, deposition, or other fabrication methods for forming conductive electrical paths. The conductor can be insulated. The conductor can also comprise any suitable MRI-compatible (and biocompatible) material such as, for example, MP35N drawn filled tubing with a silver core and an ETFE insulation on the drawn tubing.

[0116] The term "current suppression module" ("CSM") refers to an elongate conductor that turns back on itself at least twice in a lengthwise direction to form a conductor configuration of a reverse or backward section in one lengthwise

direction and proximately located forward sections that extend in the opposing lengthwise direction. The CSM can be configured with a length that is a sub-length of the overall length of the conductor, e.g., less than a minor portion of the length of the conductor and the conductor can have multiple CSMs along its length. The term "MCSM" refers to a conductor that has multiple CSMs, typically arranged at different locations along at least some, typically substantially all, of its length. The terms "backward", "rearward" and "reverse" and derivatives thereof are used interchangeably herein to refer to a lengthwise or longitudinal direction that is substantially opposite a forward lengthwise or longitudinal direction. The words "sections", "portions" and "segments" and derivatives thereof are also used interchangeably herein and refer to discrete sub-portions of a conductor or lead.

[0117] The term "MR compatible" means that the material is selected so as to be non-ferromagnetic and to not cause MR operational incompatibility, and may also be selected so as not to cause undue artifacts in MR images. The term "RF safe" means that the device, lead or probe is configured to operate within accepted heat-related safety limits when exposed to normal RF signals associated with target (RF) frequencies such as those frequencies associated with conventional MRI systems or scanners.

[0118] The term "high impedance" means an impedance that is sufficiently high to reduce, inhibit, block and/or eliminate flow of RF-induced current at a target frequency range(s). The impedance has an associated resistance and reactance as is well known to those of skill in the art. Some embodiments of the lead and/or conductors of the instant invention may provide an impedance of at least about 100 Ohms, typically between about 400 Ohms to about 600 Ohms, such as between about 450 Ohms to about 500 Ohms, while other embodiments provide an impedance of between about 500 Ohms to about 1000 Ohms or higher.

[0119] Embodiments of the invention configure leads that are safe (heat-resistant) at frequencies associated with a plurality of different conventional and future magnetic field strengths of MRI systems, such as at least two of 0.7T, 1.0T, 1.5T, 2T, 3T, 7T, 9T, and the like, allow for safe use in those environments (future and reverse standard MRI Scanner system compatibility).

[0120] The term "tuned" with respect to a coil, means tuned to define a desired minimal impedance at a certain frequency band(s) such as those associated

with one or more high-field MRI Scanner systems. When used with respect to a parallel resonant circuit with inductive and capacitive characteristics defined by certain components and configurations, the word "tuned" means that the circuit has a high impedance at one or more target frequencies or frequency bands, typically including one or more MRI operating frequencies.

[0121] The term "coiled segment" refers to a conductor (*e.g.*, trace, wire or filar) that has a coiled configuration. The coil may have revolutions that have a substantially constant diameter or a varying diameter or combinations thereof. The term "co-wound segments" means that the affected conductors can be substantially concentrically coiled at the same or different radii, *e.g.*, at the same layer or one above the other. The term "co-wound" is used to describe structure indicating that more than one conductor resides closely spaced in the lead and is not limiting to how the structure is formed (*i.e.*, the coiled segments are not required to be wound concurrently or together, but may be so formed).

[0122] The term "revolutions" refers to the course of a conductor as it rotates about its longitudinal/lengthwise extending center axis. A conductor where coiled, can have revolutions that have a substantially constant or a varying distance from its center axis or combinations of constant and varying distances for revolutions thereof.

[0123] The term "serpentine" refers to a curvilinear shape of back and forth turns of a conductor as a subset of a length of the conductor, such as, for example, in an "s" or "z" like shape, including, but not limited to at least one flattened "s" or "z" like shape, including a connected series of "s" or "z" like shapes or with additional sub-portions of same or other curvilinear shapes to define forward and backward sections of a conductor. The upper and lower (and any intermediate) lengthwise extending segments of a serpentine shape may have substantially the same or different physical lengths.

[0124] The term "Specific Absorption Rate" (SAR) is a measure of the rate at which RF energy is absorbed by the body when exposed to radio-frequency electromagnetic fields. The SAR is a function of input power associated with a particular RF input source and the object exposed to it, and is typically measured in units of Watts per kilogram (W/kg) taken over volumes of 1 gram of tissue or averaged over ten grams of tissue or over the entire sample volume, or over the

volume of the exposed portion of the sample. SAR can be expressed as a peak input and/or whole body average value. Different MRI Scanners may measure peak SAR in different ways resulting in some variation as is well known to those of skill in the art, while whole body average values are typically more consistent between different MR Scanner manufacturers.

[0125] Peak input SAR measurement is an estimate of the maximum input RF energy deposited in tissue during an MRI scan. To measure peak SAR, the following methodology using a suitable phantom can be employed. The peak SAR temperature(s) is typically measured near the surface. The phantom can be any shape, size and/or volume and is typically substantially filled with a medium simulating tissue, *e.g.*, the medium has electrical conductivity corresponding to that of tissue – typically between about 0.1-1.0 siemens/meter. The medium can be a gel, slurry, or the like, as is well known, and has conduction and/or convective heat transfer mechanisms. Peak input SAR is estimated based on temperature rise measured by the sensors placed near the surface/sides of the phantom and is calculated by Equation 1 as stated below. *See also*, ASTM standard F2182-02A, which described a way to measure input SAR.

$$dT/dt = SAR/ C_p \qquad \text{Equation (1)}$$

where: dT is the temperature rise
 dt is the change in time
 C_p is the constant pressure specific heat of water (approx. 4180 J/kg-°C).

[0126] The term "low DC resistance" refers to leads having less than about 1 Ohm/cm, typically less than about 0.7 Ohm/cm, so, for example, a 60-70 cm lead can have DC resistance that is less than 50 Ohms. In some embodiments, a lead that is 73 cm long can have a low DC resistance of about 49 Ohms. Low DC resistance can be particularly appropriate for leads that connect power sources to certain components, *e.g.*, electrodes and IPGs for promoting low-power usage and/or longer battery life.

[0127] The lead can have good flexibility and high fatigue resistance to allow for chronic implantation. For example, with respect to flexibility, the lead can easily bend over itself as shown in **Figure 49**. In some embodiments, the lead, when held suspended in a medial location is sufficiently flexible so that the opposing long segments drape or droop down together (do not hold a specific configuration).

[0128] In some embodiments, the lead can be sufficiently fatigue resistant to withstand 1 million cycles of a degree of motion that includes axial rotation and lateral translation that is many times greater than that imparted to the lead in position due to human anatomy/organ movement. The stroke cycle can be carried out at rates of between about 8-9 Hz (which is relatively fast compared to an average, resting human heartbeat rate of about 1Hz). To be considered sufficiently fatigue resistant, a lead does not exhibit breakage, breakdown of insulation (insulation resistance breakdown or cracking, splitting or rupture of insulation) or short or open circuits when exposed to the test cycles. The leads can be tested submerged in a liquid (Normal saline) using a test fixture that automatically cycles a lead through a translational stroke of about 2.9 inches. This stroke was selected to greatly exceed normal anatomical motions of the intended implant or use location of the lead (*e.g.*, a cardiac cycle for cardiac leads) or respiratory cycle for leads that reside over the pulmonary region and the like. The lead can also be configured to withstand rotation of about 180 degrees/half-cycle.

[0129] An exemplary automated test fixture **350** is shown in **Figure 54A**. The test fixture **350** includes a drive system **370** that can include a motor **370** with a gear **372** that drives a belt or chain **371** that rotates wheel **380**. A connecting rod **381** connects the wheel **380** to a linear slide block **393** that linearly slides over table **395**. The slide block **393** is also connected to a rotational member **375** such as a gear assembly, *e.g.*, a rotating gear **390** in communication with a stationary rack gear **376** (*e.g.*, a rack and pinion gear assembly). In operation, the wheel **380** rotates continuously which pulls the connecting rod and the connected linear slide back and forth causing the gear **390** to rotate thus imparting linear and rotational forces on the underlying lead **20**.

[0130] The lead **20** can be attached to the fixture **350** using a holder such as a lower extending rod **399** (*e.g.*, a PEEK (poly ether-ether ketone) rod) that is held similar to an axle **391** in the center of the gear **390** and extends vertically down into a

liquid bath (*e.g.*, an end portion of the lead can be epoxied to or mechanically attached to the rod) so that the linear translation and rotation motion of the stroke cycle generated by the wheel 380 and rotation of gear 390 are directly imparted to the lead 20. The movement is automatically carried out using the automated drive system 370 that automatically cycles the test specimen 20 repeatedly and continuously through a stroke cycle at a desired rate/frequency.

[0131] As shown in **Figures 54A**, the rod 390 is partially immersed in a temperature controlled, circulated water bath of Normal saline solution, while the lead 20 is completely immersed. The "free end" of the lead can optionally be secured with a weight to confine the motion to a region or portion of the lead. The fixture 350 can provide discrete stroke adjustments in desired increments. The wheel 380 includes several apertures 382 sized and configured to slidably receive mounting pin 383 (**Figure 54C**). The apertures 382 are radially offset at different distances from the center of the wheel 380. By placing the connecting rod/crank pin 383 in a different aperture 382, the rod 381 and the slide block 393 move a different linear distance through the rotation of the wheel 380. Also, the rack 376 is held at an adjustable location in slots 377 (**Figure 54B**). A different size diameter gear 390 (*see, Figure 54C, 390a, b, c*) can be placed on the slide block 393 and engage the stationary gear 376 to rotate a lesser amount (a larger circumference) based on the linear movement of the slide table 393. Thus, both linear and rotational movement is easily adjusted using this fixture 350. Two embodiments of leads 20 with MCSMs formed of tri-layer stacked coils were tested with this fixture and withstood over 2 million cycles and over 15 million cycles, respectively.

[0132] As noted above, the leads may be particularly suitable for medical use, and can be used with interventional or other devices and may be acutely placed externally or *in vivo* or may be chronically implantable and can include one or more of a stimulating, ablating and/or recording electrode and/or sensor. The leads may be particularly suitable for implantable lead systems for IPGs, cardiac defibrillators, cardiac pacing (CP), neurostimulation or neuromodulation (peripheral, deep brain, or spinal), EP catheters, guidewires, SCS or any cable or conductors, particularly those that operate in an MR Scanner, and the like.

[0133] The leads may be implantable, MRI compatible multi-purpose lead systems with at least one stimulating/pacing electrode (in some embodiments with

electrodes at both end portions) and may optionally be configured to provide an internal MRI receive antenna.

[0134] The leads may be particularly suitable as implantable or therapeutic devices for animal and/or human subjects. Thus, the leads can be sterilized and packaged for medical use. Some lead embodiments can be sized and configured for brain stimulation, typically deep brain stimulation. Some probe embodiments can be configured to stimulate a desired region of the sympathetic nerve chain. Other embodiments may be directed to other anatomical structures, organs or features including the heart. For example, the leads of the present invention may be configured for use in interventional procedures or as implantable leads for treating cardiac, gastrointestinal, urinary, spinal or other organs or body regions. In particular embodiments, the leads function as conventional pacemaker/ICD leads, *i.e.*, leads that sense and transmit electrophysiological signals to the pacemakers/ICDs and deliver stimulation pulse from the IPG/ICD to the cardiac tissue.

[0135] While the description below is directed primarily to medical uses, the scope of the invention is not intended to be limited thereto as, in other embodiments, the leads can be configured to connect two devices and provide substantial immunity to (common mode signals induced by virtue of proximity to) an electromagnetic radiation source and/or electromagnetic fields having frequencies between about 1 MHz to at least about 1 THz, typically between 1 MHz and 1 GHz. The electromagnetic radiation source can be from RADAR, communications transmission, *e.g.*, satellite or extra-territorial and territorial based cellular systems, television transmission, and/or radio transmission. The lead may be used as an external non-medical device. The lead may also be configured for both internal/external use or combinations thereof. For example, the lead can be configured as an implantable or interventional (acutely placed) medical lead that connects two internal devices, such as one or more electrodes to an IPG, a medical lead that connects one internal device to an external device (*e.g.*, a therapeutic delivery device such to an external power source, control unit or supply), or an external medical lead that connects two external devices (such as a grounding pad to an RF generator for an EP (electrophysiology) ablation procedure).

[0136] Generally stated, embodiments of the invention are directed at single or multi conductor leads where the conductor(s) of the lead are arranged so as

to reduce RF pickup by the lead during exposure to electromagnetic fields, such as, but not limited to, those associated with RF pulse sequences used with MRI Scanners. The conductors can be arranged in multiple CSMs along the length of the lead. In some embodiments, the CSMs can be configured to have low impedance of between, for example, 5-30 Ohms, while in other embodiments, the CSMs can have an impedance of greater than about 50 Ohms, *e.g.*, an impedance of at least 100 Ohms, such as at least about 200 ohms, at MRI frequencies and the electrical length can be configured to be about or shorter than a quarter wavelength in a physiological medium in the electrical field. This configuration may significantly reduce coupling of the lead to the RF induced in the body during an MRI scan, and propagation of the current along the length of the lead and into the tissue adjacent to any associated electrodes that the lead may optionally have.

[0137] During an MRI scan, the patient is placed in a constant magnetic field; external RF magnetic field pulses are applied to change the orientation of the nuclear magnetism and thus obtain signal from the sample: for example, at 1.5 Tesla (T) this applied RF magnetic field has a frequency of about 64 MHz. This field is perpendicular to the MRI scanner's static magnetic fields, and is linearly or circularly polarized. The RF magnetic field can have associated with it an electric field, whose spatial distribution depends on the geometry of the MRI scanner's excitation coil and on the patient, but generally has the greatest amplitude closest to its conductors. The applied RF pulses can directly induce an electric field with an associated voltage and current in the metallic leads, implants (especially elongated ones) and conductors, consistent with Faraday's Law and Maxwell's equations, as is well known to those skilled in the field of Electricity and Magnetism. Further, the applied RF pulses generate local electric fields in the body that can be effectively focused by the presence of metallic implants and electrical leads. In both cases, any voltages and currents that are induced in the conductors of the lead may cause them to resistively heat. Leads for use with implanted devices, monitors and IPGs are typically designed for the conduction of direct current (DC) or audio frequency (AF) signals, and are typically electrically insulated along their length except for electrode contacts. However, such DC/AF insulation typically provides little or no impediment to RF signals passing between tissues and the conductors, noting for instance that insulated wires are routinely used on wires without affecting their ability to detect FM radio

signals at 81-108 MHz. Thus, it is conceivable that induced voltages and currents induced in such leads or implanted devices can be deposited in the tissue adjacent to the lead, electrode(s) and implanted devices. In cases where electrode(s) have small surface contact areas with tissue, and where the electrode is at a terminal end of a lead such that the induced current and voltages are higher than on the rest of the lead, the contact tissue may present an increased risk of heating. Similarly, at terminal ends of leads that connect to implanted devices such as IPGs, excessive levels of induced currents and voltages may conceivably damage the device.

[0138] Devices incorporating designs and arrangements of conducting implantable leads according to embodiments of the invention can significantly ameliorate sensitivity to induced RF currents and RF power deposition and/or other RF or MRI based heating phenomena. These arrangements can reduce the magnitude of the induced RF current and/or voltages, thereby suppressing to a significant extent the RF power deposited on and/or associated with the lead, and consequently deposited in tissue adjacent to the lead (and electrode(s)). By this, the local temperature rise in the tissue adjacent the lead and/or electrode(s) is reduced.

[0139] Typically, as exemplified for *in vivo* 1.5T and 3T MRI results herein, the lead is able to heat local tissue less than about 10 degrees Celsius above ambient or body temperature, more typically about 5 degrees Celsius or less, when a patient is exposed to target RF frequencies at a peak SAR of at least about 4W/kg, typically up to at least about 20W/kg, and/or a whole body average SAR of at least about 2W/kg, typically up to at least about 10 W/kg. In some embodiments, with a peak input SAR of between about 4 W/kg to about 12 W/kg, the lead can induce a limited increase in temperature of less than about 6 degrees Celsius, typically about 5 degrees or less, with the temperature increase at a peak SAR of about 4.3 W/kg being less than about 2 degrees Celsius so that a maximum temperature rise associated with the lead is less than about 2 degrees Celsius. In some embodiments, the lead is able to heat local tissue less than about 6 degrees Celsius when exposed to a peak SAR of between about 8W/kg to about 12 W/kg, with the temperature increase at a peak SAR of about 8W/kg and/or a whole body average SAR of about 4W/kg is typically less than about 4 degrees Celsius, and, in some embodiments can be below about 1 degree Celsius.

[0140] While not wishing to be bound to any particular theory of operation, it is contemplated that embodiments of the invention can employ one or more functional underlying mechanisms incorporated by arrangements of conductors to thereby suppress and/or minimize RF coupling, induced currents, and/or RF power deposition when implemented as external, implantable or intrabody leads subjected to RF EM fields. These suppression mechanisms shall be discussed further below, in embodiments of the invention detailed herein.

[0141] As noted above, the leads can be used in several situations where individuals who have external or implanted conductors and devices may be exposed to EM fields that could induce currents in them and thereby present a safety concern or equipment malfunction, such as, for example, but not limited to, RADAR, radio, wireless (cellular) telephone or communications and TV transmission and reception installations/facilities/equipment (fixed or mobile), RF devices, as well as MRI. Without limiting the intended scope of the current invention, for illustration purposes only, the description primarily describes embodiments of the invention in the context of exposure to RF in the context of medical MRI situations, such as, for example, during an MRI guided interventional procedure or during MRI diagnostic imaging procedures.

[0142] While not wishing to be bound to any particular theory of operation, it is currently believed that when a body such as a human or animal or a biologically analogous model object ("phantom") is placed in an MRI scanner and an external RF magnetic field pulse is applied to the body to excite tissue for MRI during the scan, local electric fields ("E fields") from the excitation coil and eddy currents can be induced in the body. The magnetically induced eddy currents are in a direction orthogonal to the applied RF field and at the same frequency. Magnetic flux may also be generated. When one or more conductors are placed in the body, they can couple with the local E-fields and eddy currents can be deposited on the conductors 2 of the lead 1 as shown in **Figure 1**. Because the applied excitation fields will in general be substantially uniform over the cross-sectional dimension of the one or more conductors, the coupled and induced currents in the conductors are in the same direction, and shall henceforth be termed "common mode currents". This current travels back and forth at the RF, and can cause a local temperature to rise to unsafe levels especially where currents peak at the ends, in tissue adjacent to electrodes, for

example as shown in **Figures 1 and 2**. **Figure 2** illustrates temperature rise on two different leads, an SCS (spinal cord stimulation) lead and a DBS (deep brain stimulation) lead. The local temperature rise can be proportional to the total RF power deposited on the conductor, which is a function of: the applied RF field strength, frequency and duty cycle; the electrical length of the conductor in the body, which is a function of the conductor's RF impedance (its conductivity, insulation thickness and the complex impedance of the environment around the conductor); and the size and RF electrical properties of the body.

[0143] In reference now to one theory of operation with respect to the common mode currents, if two conductors (*e.g.*, wires or filars) of substantially equal or equal electrical length (the electrical lengths and need not be the same as the respective physical lengths) are placed in the same electromagnetic (EM) fields in the same orientation, the magnitude and direction of current deposited on them will be substantially the same or the same. Now, it will be seen, in accordance with some embodiments of the present invention, that these conductors may be arranged in such a way so as to suppress (balance, offset, null, reduce and/or limit) the common mode currents by forming a conductor that turns on itself two or more times, *e.g.*, formed into sections that include lengths whose direction is reversed in a longitudinal and/or lengthwise direction. By this configuration, it is contemplated that a reduction or a cancellation of the common mode current in an electrically equivalent forward length of conductor may be affected, thereby substantially reducing the overall current, which flows to the ends of these conductors. However, it will be appreciated that with this concept, the conductor (*e.g.*, wire) still traverses the distance from one component to another, *e.g.* an electrode to an implanted device or IPG. In accordance with embodiments of the present invention, the electrical length of reversed sections are modified so as to alter their physical length, while providing a canceling, nulling or offset affect of common mode currents. The lengths of the sections are chosen based on considerations described hereinbelow, which also include factors that relate the impedance and transmission line characteristics of the conductor, and/or its EM wavelength. The reverse sections can have a physical length that is less or the same as at least one adjacent (neighboring) forward section and may have an electrical length that is less, the same or more than that of the at least one adjacent (neighboring) forward section.

[0144] Referring to **Figure 3**, three different conductor configurations are illustrated. The top conductor **2** configuration is of a 27 cm long straight conductor. When this configuration conductor was placed in a simulated tissue gel phantom and subjected to external RF fields in a 1.5T MRI scanner operating at about 64 MHz, a local temperature change of about 20°C was measured in the tissue adjacent to the electrode (*see, Figure 8C*). In contrast, modifying the 27 cm conductor **2** configuration as shown by conductor **3** with the conductor **3** turned upon itself (in about 9 cm sections) to define a conductor portion or segment having a BS section **10** and two FS sections **9** causes a substantially lower local temperature change, measured as less than about 1°C during the same MRI scan carried out for conductor **2**, which is similar to that seen with a conductor **5** having a 9 cm conductor as shown by the bottom conductor configuration. Conductor **5** has a physical length of about 9 cm and may have an electrical length of about $\lambda/4$ or less. The temperature reduction is believed to reflect reduced coupling to the local E-fields because of the reduced length of each section (9 cm vs. 27 cm). In the context of some particular embodiments of the invention, a common mode current may be induced in all three sections of the turned 27 cm conductor **3**. However, again according to one contemplated theory of operation, the current in one forward section **9₁** of the conductor **3** may be thought of as being canceled or reduced by the current in the reverse (backward) section **10**, leaving a reduced (or net un-canceled) current in the third (9 cm) section **9₂** consistent with this conductor **3** producing substantially the same heating as the shorter (9 cm) length conductor **5**, alone. However, other or additional operational mechanisms may be responsible for the reduced heating.

[0145] As shown schematically by the lead configuration in the middle of the three leads in **Figure 3**, reversing the direction of the conductor **3** appears to offer an induced current suppression mechanism that is potentially frequency non-specific and might be considered “broadband” suppression. However, in practice, several factors that are frequency dependent can be considered. In particular, at RF of about 30 MHz and higher, the length of implanted leads can become comparable to the EM wavelength of current in the leads, which generally results in modulation of the currents as a function of distance along the lead due to the EM wave, which can cause any heating that occurs in the exposed sections (**9₁**, **9₂**, and the like) to vary with

position in response to variations in the current amplitude, and can thereby modulate the common-mode suppression strategy outlined above.

[0146] Accordingly it may be desirable in some embodiments of the present invention to divide the long conductors used in lead systems into a plurality of individual RF-induced current suppression modules **8** that are small compared to the wavelength. Thus, in some embodiments, each individual CSM **8** or a respective BS **10** and/or FS **9** thereof may have an electrical length that is preferably no more than about $\lambda/4$, typically shorter than $\lambda/4$, where λ is the EM wavelength of the conductor in the body at the RF of interest (*e.g.*, the operational frequency of the MRI scanner). Generally stated, each module **8** has at least two sections, a forward section (FS) **9** and a backward section (BS) **10**. The FS **9** and BS **10** can have similar or substantially equal electrical lengths, and thus experience a similar extent of coupling to the EM fields and similar magnitudes and direction of induced common mode current when immersed in the same EM fields. According to one common mode current suppression mechanism theory, these similar magnitudes and directions of the currents induced in the forward and backward sections can be thought of as meeting each other at the ends of each section, resulting in a substantial cancellation of the current, as distinct from conventional straight leads wherein the current(s) can continue unabated and even increase, potentially causing undesired heating. Other non-equivalent electrical length configurations may be used, for example, a shorter electrical length in a FS **9** relative to a corresponding BS **10**, and in the location of the BS **10** on a proximal length, or on a distal length, relative to the overall physical length of the conductor **3** (*e.g.*, wire or filar), and/or symmetrically disposed relative to a first turn or bend in the conductor **3**.

[0147] The electrical length and wavelength (λ) of a conductor is a function of its physical length, RF impedance, the insulator/dielectric material surrounding it and the electrical properties of the medium it is placed in. For example, at 64MHz and in a saline solution (0.9%) a copper wire of the type used for winding magnetic coils (“magnet wire”) 9 cm long is roughly equal to $\lambda/4$. If insulation is added to the conductor, depending on the insulation thickness and dielectric constant of the insulation, λ increases, *i.e.*, the 9 cm long conductor with insulation now has an electrical length that is shorter than $\lambda/4$. Also, coiling a length of the conductor can affect the effective physical and electrical lengths. The $\lambda/4$ length of the coil depends

on the diameter of the conductor and the diameter of the coil. For example, as shown in **Figure 4**, a 9 cm straight conductor (*e.g.*, magnet wire) **9** is electrically equivalent in length to a wire **10** having a 3.5 cm straight section **10s** and a 1.5 cm coil **10c** formed of the conductor (*e.g.*, magnet wire (diameter 0.040" ID)); and to a ~2.5 cm of the same conductor (*e.g.*, magnet wire) coiled **10c** to an ID of 0.040" (**Figure 9**). **Figure 5** illustrates that the backward section **10** has a coiled section **10c** and an overall physical length " L_{CB} " of about 5 cm to provide substantially the same electrical length as the forward section **9**, shown here with a linear (straight) length of about 9 cm.

[0148] As will be discussed further below, one or both of the FS **9** and/or BS **10** segments of each or some CSMs **8** on a lead may each be coiled or comprise coiled segments. According to embodiments of the present invention, in operation, sections **9** and **10** are subjected to the same or a similar EM field such that the common mode currents are induced in the same direction, depicted here by arrows, will provide a certain level of cancellation where the sections meet. It would appear that if sections **9** and **10** are of electrically substantially equivalent lengths, and if the EM field is the same across the lengths of both sections, then cancellation should be complete. However, it is appreciated that, in practice, current cancellation may not be 100% for various reasons, including for example variations in the coupling electric field in the two sections, but is sufficient to suppress common mode current(s) to within acceptable limits. *In vitro* tissue heating tests of leads configured as shown in **Figure 7** resulted in local temperature changes in the gel surrounding the test lead of ~1°C as shown in **Figures 8A** and **8B**.

[0149] In considering the mechanisms by which induced currents are ameliorated according to embodiments of the present invention, it will be recognized in addition that the FS and BS portions **9**, **10** of proposed current suppression modules **8** have RF electrical impedances comprised of the total resistance of the section, and a reactive component comprised primarily of the inductance of coil portions. It will be understood by those skilled in the art that the term "coil" can include discrete circuit inductors (which are typically micro-wound coils; non-magnetic and MRI-compatible for MRI applications) in addition to those coils formed by the conducting leads.

[0150] In addition, the reactive component may include parallel capacitance depicted as connecting between FSs **9** and BSs **10** and that is distributed

mutually between lead sections or included as discrete components, as well as stray capacitance between the surrounding environment in which the lead is placed, as illustrated in **Figure 6A**. The distributed capacitance may vary from being of negligible value to tens of pF. Discrete circuit elements (capacitances and/or inductors) may also be used in series in the lead in accordance with embodiments of the present invention. The reactance is a determinant of the EM wavelength in the sections, and their electrical lengths as discussed above. Thus, when considering the impedance properties of the modules **8**, the conductor arrangements of FS **9** and BS **10** as shown in **Figure 5**, may potentially be thought of as adding the benefit of a high-impedance filtering effect when the magnitude of the impedance at the RF frequency of interest is large, for example ≥ 100 Ohms. In general, this can occur over a range of frequencies, and in addition, higher levels of filtering can be expected at certain specific frequencies where the conductor electrical lengths correspond to integral multiples of $\lambda/4$. While the latter property may be limited to a relatively narrow RF range (“narrow-band” suppression), the RF filtering may be due to the impedance of the modules that is typical of that of inductor-capacitor (LC) circuits: the impedance at a particular frequency is determined by the series inductance formed substantially by the coils incorporated into the sections, and by the parallel capacitance, which can arise between the conducting lead and the adjoining environment, including nearby conductor portions (*e.g.*, **9** and **10**).

[0151] Thus, when considering impedance effects, as exemplified in **Figures 5, 6A-6E, 9** and **10**, the substantially straight sections **9** in conjunction with the BS coiled section **10c** may be thought of as forming an LC circuit that provides an RF filter affect. As shown schematically in **Figure 6A**, the coiled section **10c** can be an electrical equivalent of a series inductor and a capacitance **7** that may be created by a (insulated) coil between the straight section **9** and the coiled section **10c**, insulated by a dielectric (*e.g.*, a polymer), thus potentially creating a high impedance which suppresses induced RF currents. **Figures 6B-6E** are schematic illustrations of a conductor with a CSM **8** of forward and reverse segments **9, 10** and exemplary capacitance configurations according to embodiments of the present invention. In these embodiments, the capacitance/capacitors are used in conjunction with the inductance of the conductor (**Figures 6B, 6C, 6D**) or with one or more coiled sections (**Figure 6E**) to reduce the physical length of the lead for a fixed electrical length in

order to suppress common mode currents and/or to provide the a high impedance RF filtering effect. Note that of these, **Figures 6C and 6D**, may not be suitable for applications involving passage of direct currents (DC) or low frequency currents for pacemakers etc..., due to the presence of the series capacitances. A purpose of the series capacitances in **Figures 6C and 6D**, can be to augment the impedance of a FS **9** to further improve the RF filter effect. The embodiment of **Figure 6E** includes a coil **9c** in FS **9** in addition to the one in BS **10**. These coils are wound in opposite directions to each other, and may be cowound with the FS conductor **9** next to the BS conductor **10** at substantially the same coil radius, or wound one on top of the other in two or more layers, or consecutively coiled. A purpose of the added coil **9c** can be to augment the impedance of a FS **9** to further improve the RF filter effect, and may be of different length, diameter, and possess a different impedance from **10c**. Also, coil **9c** may be formed in either or both of the upper and lower FS **9** portions. When using only a distributed capacitance, **Figure 6E**, may be accomplished just by forming conductor **3** into FS coils **9c** and BS coils **10c**.

[0152] It will now be seen that these concepts and principles of embodiments described herein can be extended to embodiments including longer leads, multiple CSMs **8** with respective FS and BS sections **9, 10**. One or more of the CSMs **8** can include BS sections **10** having coiled portions **10c** and FS sections **9** having coiled portions and leads **20** can include a plurality of conductors **3**, as depicted, and described in the examples presented hereinbelow.

[0153] **Figure 7** depicts a prototype single lead system that has a length L_1 (such as about 36 cm long) with a single electrode **4** showing four of six RF induced current suppression modules **8** each with two FSs **9** with a length L_2 (such as about 9 cm long) corresponding to approximately $\lambda/4$ at 64 MHz, and each with one with a BS **10** with a length L_3 (such as about 5 cm) including a longer straight length L_4 (of about a 3.5 cm) and a shorter coiled length segment (of about a 1.5 cm) **10c**. In the embodiments shown, the conductor is formed from 0.007" diameter magnet wire and the coiled sections **10c** have an inner diameter of 0.040". In considering the impedance of each suppression module **8**, the coiled BS **10** provides the inductance, and FS **9** couples with the inductor, with the stray capacitance contributed by the electrical coupling between the FSs **9** and BSs **10** themselves and the environment. In considering the common mode induced currents in each section, since both the

respective sections **9**, **10** of the module **8** are in close proximity, they can couple to substantially the same local E-fields and have substantially the same direction of RF current induced in them at a given time, so that, in accordance with the above discussion, the current deposited on the forward section **9** may be thought of as being cancelled to a significant extent by the current induced in the backward section **10** at the point where the sections meet, and overall less induced current flows toward the electrode **4** and into the adjacent tissues compared to that which occurs without CSMs **8**.

[0154] The prototype shown in **Figure 7**, underwent *in vitro* tissue heating tests in a 1.5T MRI scanner operating at 64 MHz by placing it in an gel medium having similar electrical properties as a healthy muscle (conductivity, 0.7 Siemens/m conductivity). Local temperature rise in various sections (namely in gel adjacent to electrode **4**) was measured using a fiberoptic temperature measurement system. **Figure 8A** illustrates the change in temperature ($^{\circ}\text{C}$) versus time (sec) for this lead in the gel at the electrode end, which is less than 0.5°C . In contrast, a control lead of a straight conductor of the same length in the same field displayed a 20°C temperature rise in the gel adjacent to the electrode (**Figure 8C**).

[0155] A 27 cm prototype was fabricated according to the design shown in **Figure 7**, but with a reduced number of modules **8** (four versus six) with the same FS **9** and BS **10** configurations. **Figure 8B** illustrates the *in vitro* tissue heat test data performed under the same conditions. The heating at the electrode is slightly higher for the 27 cm lead, at about 1°C , but remains within an acceptable range and greatly reduced compared to the 20°C seen in some conventional leads (**Figure 8C**).

[0156] Another embodiment of a CSM **8** in accordance with the present invention is shown in **Figure 9**, which depicts a portion of the conductor **3** with a single suppression module **8** that can be used to form a four-electrode and/or four-conductor lead **20**. In this case, each backward section **10** has a coiled segment **10c** that runs substantially the entire length thereof, for example, about 2.5 cm, rather than about 1.5 cm, as noted above. Other lengths and coil diameters and coil sizes may also be used. As also shown, the four conductors or leads can be co-wound to provide cowound coiled sections **10c** of sections **10** to counter the common mode currents. Other configurations are possible including, for example, forming the coil **10** outside and surrounding the FSs **9** and BSs **10**, such that each lead set reverses directions and

runs back through the middle of the coil to its opposite ends to provide the cancellation effect discussed above. As shown in **Figure 10**, from the standpoint of the RF impedances of the lines, the coils **10c** may serve as series inductances, which, together with stray capacitance **7** with other sections **9** and/or surrounding environment, provide a current suppression affect.

[0157] A multi-electrode, multi-conductor lead system **20** is illustrated in **Figure 11** for a four electrode **4** and/or four conductor **3** lead system **20**. **Figure 11** illustrates a subset of the modules **8**, *e.g.*, five CSMs **8** of an exemplary 11 CSM conductors of a 58 cm lead **20**, and five CSMs **8** of 12 CSMs of conductors of a 64 cm lead system. For prototypes of the design shown in **Figure 11**, each lead **20** was made with four conductors, namely 0.005" magnet wires (4 wires), each having a straight FS **9** about 9 cm long, and a coiled BS **10c** (also interchangeably called a "CBS") about 4.3 cm long. The coils **10c** had a 0.046" ID with respective coiled segments **10c** of the different conductors being substantially co-wound. Multiple digital photographs of a prototype lead **20** for connecting between electrodes and an IPG or pacemaker are shown in **Figures 12A-D**: **12A** the entire lead; **12B** the distal end showing the electrodes; **12C** and **12D**, close-up photographs of the modules **8** and coils **10c**. These leads **20** were tested for *in vitro* tissue heating performance in a gel phantom in a 1.5T (64 MHz) MRI scanner system. The local temperature changes in the gel around different sections of the lead (distal end "DM1", proximal end "PM1", near electrode "electrode") were measured and are reported in **Figures 13A** and **13B**. Less than a 1°C temperature rise was recorded in the gel adjacent to the lead **20** at these three locations when using an MRI sequence having a peak SAR input of >4 W/kg.

[0158] While a four-electrode **4** containing four CSMs **8** is shown in **Figure 11**, CSMs **8** for multi-conductor lead systems can typically comprise between about 2-100 conductors **3** and/or electrodes **4**, but even greater numbers of conductors **3** and/or electrodes **4** can be formed according to the embodiments described herein are included within the scope of the present invention.

[0159] In embodiments of the present invention, one or more such CSMs **8** of the type illustrated in **Figure 11** for multiple conductors can be arranged so that a CSM **8** of a respective conductor is separated from a neighboring CSM **8** by an electrical length of $\sim\lambda/4$ or less, analogous to the single line arrangement depicted in

Figure 7, where λ is the EM wavelength of the straight (uncoiled) lead in the medium in which it is to be implanted. Although shown as having electrodes **4** on both ends, in other embodiments all electrodes may be at one end portion and connectors/interfaces to the power source or other device at the other end. Alternatively, multi-electrode and/or multi-conductor (>2 conductor) embodiments of the present invention can include conductors having separate suppression modules as shown in **Figure 7**. The multiple conductors **3** can be grouped with the coil locations **10c** displaced one from the other so that the coils **10c** do not coincide in space, and the maximum lead diameter does not become excessive. Combinations of cowound and non-cowound coiled sections and grouped or ungrouped conductors may also be used. In some embodiments, each coiled segment of a respective conductor can be axially (displaced lengthwise) with respect to others, while in other embodiments some or all of the conductors can be stacked one over the other and/or cowound.

[0160] The configuration details of the conductors **3** and CSMs **8** are for illustration purposes only and not meant to limit the scope of the present invention. While not wishing to be bound to one theory of operation, it is contemplated that the primary purpose of one or more of the cooperating pairs of forward and reverse sections, the coil sections **9c** and/or **10c**, and/or the reactive elements depicted in **Figure 6A-E** (coils and/or capacitors) is to alter the electrical length of the associated conductor lengths so that common mode currents induced on longer sections can be suppressed, offset or inhibited and an electrical connection can be provided between physically separated parts, such as electrodes and IPGs or pacemakers, or external EKG leads (or blood pressure transducer, or blood oxygen transducer, or sonography transducer) and a monitoring system, for example.

[0161] **Figures 12A** is a digital photograph of a prototype flexible lead according to embodiments of the present invention. **Figure 12B** is a partial view of the prototype shown in **Figure 12A** with the end of the lead shown straight with respect to a ruler. **Figures 12C-12D** are enlarged images of a portion of the lead shown in **Figure 12B**.

[0162] **Figures 13A** and **13B** are graphs of temperature change (C) over time (seconds) for four electrode and four conductor prototype lead systems according to embodiments of the present invention. The graph in **Figure 13A** illustrates temperature rise over time at a distal end of a CSM module 1 (DM1) and at a

proximal end of CSM 1 (PM1) and in the gel near the electrode if a 4 electrode lead system with 4 conductors and 11 CSM modules having a length of about 58 cm. The graph in **Figure 13B** illustrates the temperature rise of a 64 cm long prototype lead with 4 conductors and 4 electrodes and 12 CSMs.

[0163] In particular, **Figures 14A-14I** illustrate exemplary CSM 8 configurations with alternative conductor 3 configurations and BS 10 and FS 9 according to some embodiments of the present invention as applied to a single conducting lead 3. In **Figure 14A**, conductor 3 has BS 10 with a coiled segment 10c that runs substantially the entire length thereof analogous to the CSM shown in **Figure 9**. **Figure 14B** illustrates that one FS 9 may extend inside the coil of a BS 10 to provide the cancellation effect discussed above. The FS 9 passing through the coil may pass through any interior portion of the coil, thereby generally resulting in a reduction in the outer diameter of the lead as compared to **Figure 14A**, but also affecting the RF impedance. This configuration is readily extended to multiple co-wound leads, for example with respect to **Figure 9**, by running one bundle of leads FS 9 through the middle of co-wound coil 10c, to minimize lead diameter. **Figure 14C** and **14D** illustrate that a FS 9 can axially loop or turn several times above, below and/or through a BS 10 (defining several "mini" or "sub" FS 9₁, 9₂ and an intermediate "mini" BS 10₁) before extending axially downstream of the primary BS 10. The looping back and forth in this configuration provides an additional means of altering the electrical length of the section in accordance with the mechanisms of operation discussed above, thereby essentially creating a coil/inductance as in **Figure 14A**, but with coil axis rotated about 90 degrees to augment coil 10. **Figure 14E** illustrates that the FS 9 can include a coiled segment 9c and a linear segment 9l, analogous to **Figure 6E**. The coiled segment 9c can reside proximate the BS 10c. The BS coil 10c and the FS coil 9c can be substantially cowound but with each coil in opposing directions or coiled over or about one another or proximate each other to electrically couple, potentially produce current cancellation at the end of the BS and may generate increased impedance, such as, for example at least about 100 Ohms, and typically about 300 Ohms or more. The coil diameter, conductor size and/or type, and length of coil may be the same in the 9c and 10c sections, or one or more of these parameters may be different. The conductor 3 can be a single continuous conductor

along substantially its entire length, and is typically the same conductor at least along a length of a respective CSM 8.

[0164] **Figure 14F** illustrates that the conductor 3 can include a continuous closely spaced section of conductor that turns on itself several times in a lengthwise direction, analogous to the axial/lengthwise turns or loops introduced in embodiments **Figure 14C** and **14C**. This configuration is similar to that in **Figure 14A**, except that the coil axis is rotated 90 degrees, whereupon multiple BSs 10 are created by the coil windings. **Figures 14G-14I** illustrate yet other conductor CSM 8 configurations with a plurality of adjacent longitudinally extending back and forth lengths (which may be straight, taper or may be curvilinear) forming a series of stacked reverse and forward segments 10, 9, respectively. Although not shown, one or more coils 3c may extend between the adjacent CSMs 8, such as is shown in **Figure 14K** (which also illustrates that the CSM 8 can include one double turn (one reverse segment) configuration. **Figure 14J** illustrates a configuration similar to **Figure 14K** but without the coiled intermediate segment 3c. Of course, the lead can include combinations of different types and configurations of CSMs 8.

[0165] **Figure 14H** illustrates that the modules 8 can include both the side (lengthwise) extending segments and a coiled segment with the side extending segments being inside and/or outside the coiled segment and the coiled segment can be a forward or a reverse segment, analogous to **Figure 14C**. **Figure 14I** illustrates that the side segments of adjacent modules 8 in **Figure 14G**, may be interleaved in part. In further embodiments, the interleaving of the conductor(s) is extended in whole, so that the axial and/or lengthwise loops are cowound and form a single module. This can be obtained, for example, by forming a flat loop of conductor at the center of module 8, then folding the loop several times and laying it against the two FSs 9. An alternative embodiment is to wrap the flat loop as a coil around a FS 9.

[0166] **Figures 14L** and **14M** illustrate that the lead 20 can have at least one conductor 3 at least one CSM 8 that extends between an electrode 4 and a power source, such as an IPG. **Figure 14M** illustrates that the distal end of the conductor 3 can be coiled as it connects to the electrode 4 to further reduce heating proximate the electrode. Also, **Figure 14L** illustrates that more than one conductor 3 may be used to connect a single electrode 4 for redundancy and/or lower power or energy transmission or the like.

[0167] **Figure 15A** illustrates impedance versus frequency for a single CSM when immersed in a physiological saline solution. The CSM comprises 4.3 cm Coiled Back Sections (CBS) and 9 cm (straight) forward sections (FS). The CSM has 4 cowound conductors (for prototype proposes, magnet wires, 0.005" diameter) with the CBS having about a 0.046 inch inner diameter. **Figure 15B** illustrates that the impedance can be measured by connecting the impedance measurement probe to the CSM at the two points shown by the arrows.

[0168] **Figure 16** illustrates impedance versus frequency for an entire lead with eleven axially spaced consecutive CSMs, when immersed in a physiological saline solution. The lead is a 4 electrode system with FS having a length of about 9 cm and the CBS having a length of about 4.3 cm and an inner diameter of about 0.046 inches. The use of multiple CSMs may alter the impedance dispersion in accordance with the cumulative impedance and wavelength effects associated with the longer lead length. The impedance data shows very low resistance (~1 ohm) at DC frequencies and around 60-300 Ohm impedance at RF frequencies, although a peak of around 1600 Ohm is evident at ~20 MHz. Thus, the conductors 3 can have broadband low pass filtering, while affording a higher impedance narrowband filtering effect at specific frequencies.

[0169] Although the local maxima of the exemplary impedance is shown at between about 20-25 MHz, the location and/or maxima impedance characteristics can be adjusted to other desired RF frequencies by re-configuring the CSM, *e.g.*, changing one or more of the length of the BS 10, the diameter of conductors defining the coil 10c (*e.g.*, inductors) and/or or part of the FS 9c, and/or the number of revolutions on the conductors in the coiled BS 10c. Also, the leads 20 can be configured with multiple FSs 9 and BSs 10, to generate maxima at multiple frequencies (or frequency bands) by adjusting the configuration, *e.g.*, length/diameter/number of revolutions of different ones of the FSs 9 and/or BSs 10.

[0170] Thus, according to some embodiments, the conductors 3 with CSMs 8 can have an impedance that varies and exhibits local maxima at a frequency band and/or over a target frequency range. In some particular embodiments, the CSMs 8 can exhibit an impedance of at least about 100 Ohms over its respective length at a target radio frequency of interest. The FS and BS sections 9, 10, respectively, can be configured such that at least one local impedance maxima

substantially coincides with at least one frequency (or frequency band) of interest (*e.g.*, 64 MHz for 1.5T, 128 MHz for 3T, etc.) within that range. Because the local maxima are relatively broad, the target frequency band can be within +/- about 5 MHz of the typical RF frequency of an MRI scanner. In some particular embodiments, the target impedance local maxima can also be the global maximum.

[0171] **Figure 17** shows heat-test data from the eleven-CSM lead whose geometry and impedance properties are shown in **Figure 16** obtained using the MRI parameters: FSPGR sequence, TE=4.2, TR=17.3, BW=125, FA=170, 256=128 image matrix; TG=155 – peak input SAR~4.2 W/Kg. **Figure 17** is a graph of local temperature change measured at different locations along the length of the lead with eleven CSMs (corresponding FS and CBS) in a 1.5T MRI scanner operating at 64 MHz. The test method is as described with respect to **Figures 8A-8C**.

[0172] **Figure 18** illustrates local temperature change measured at different locations along the length of a lead with eleven CSMs in a 3T MRI scanner with measured peak input SAR=4.2 W/Kg. The MRI RF frequency in this case is 128 MHz. The lead corresponds to that analyzed with respect to **Figures 16 and 17**, and the same test method as described for **Figures 8A-8C** was used.

[0173] It is noted with reference to the eleven CSM lead depicted in **Figures 16-18**, that impedance maxima in **Figure 16** do not exactly coincide with the two MRI frequencies of 64 and 128 MHz. Nevertheless **Figures 17 and 18** show that the leads are still highly effective at limiting heating at the higher frequencies. This is consistent with the common mode mechanism playing a significant role at the frequencies of interest. Also, the same lead can be effective at limiting heating at two MRI scanner frequencies, *e.g.*, both at the 1.5T frequency and at the 3T frequency, and thereby potentially provide suppression of potentially injurious lead heating and/or device damage in multiple MRI scanner and/or RF environments. In particular, the conductors 3 may provide for rejection of induced voltages and currents over a broad band of RF in the range between about 10 MHz to about 200 MHz. In some embodiments, the local maximas can correspond to two or more RF frequencies of interest, where one or more is an RF MRI frequency corresponding to 0.1, 0.3, 0.7, 1.0, 1.5, 2.5, 3, 4, 4.7, 7, and 9.4 Tesla.

[0174] **Figures 19 and 20** are graphs of impedance versus frequency (MHz). In these graphs, embodiment "B" refers to the embodiment shown in **Figure**

14B, embodiment "C" refers to the embodiment shown in **Figure 14C** and embodiment "D" refers to the embodiment shown in **Figure 14D**. Each embodiment is able to generate multiple local maximas over an RF frequency range (MHz) with Embodiment C generating about 1000 Ohms at between about 70-80 MHz and generating over 200 Ohms between about 50-100 MHz. The word "flooded" means that there was no polymer layer on the conductor (magnet wire) CSMs so that the conductors are in complete contact with the surrounding medium (saline or gel).

[0175] As shown, the conductors **3** can be configured to increase the impedance and/or shift the frequency of local maxima of the impedance depending on the length of the CSM (FS **9**, BS **10**, FS **9**) and the orientation of the FS **9** with respect to the coiled BS **10c**. In general, discrete or distributed impedance elements such as inductors and/or capacitances, may be included in the leads for increasing impedance or tuning the local impedance maxima and providing desirable current suppression capabilities.

[0176] It is further noted that the conductors **3** and/or current suppression modules **8** may incorporate one or more of the above configurations described above and/or other features, such as, for example, but not limited to, one or more of the following:

- 1) Thicker insulation on the FSs **9** as compared to the BSs **10**. Thicker insulation on the FSs **9** of the current suppression module **8** may reduce the current deposited on FSs **9** and thereby allow the length of the forward section to be increased.
- 2) In other embodiments, shielding of the conductor(s) **3** and/or the lead FSs **9** can inhibit RF deposition and thus reduce the current deposited on the FSs **9** as compared to no shielding. Discrete or wound RF chokes as inductive elements, and/or capacitive elements may be arranged between the shielding to provide improved suppression capabilities. The shielding can be continuous, discontinuous, or may be achieved by multiple methods, to list a few, *e.g.*, insulating conductors with polymers filled with conducting metals doped for conductivity, a braided covering and the like.
- 3) Making the FSs **9** physically longer than the BS **10**, but forming the FSs **9** to be electrically substantially equivalent or of shorter length.

4) Different ones of the RF-current induced suppression modules **8** for a respective lead or a respective conductor can be configured to have a different physical length and/or configuration to provide a desired electrical length and RF current suppression at a different operational frequency. For example, for a multi-electrode system, some of the RF-current induced suppression modules **8** thereof can be configured to provide the $\lambda/4$ wavelength or less at a different MRI scanner frequency than others, allowing for compatibility with different high-fields, for future compatibility or backward compatibility.

5) The lead can be between 1 French to about 40 French. For cardiac leads, the size can be between about 1 French to about 10 French. The lead and conductors may be flat or have a geometric shape, tubular or otherwise. The lead is typically flexible but can be configured to be substantially rigid.

[0177] In some embodiments, standing wave formation on long (coaxial) conductors may be attenuated by incorporating balun circuits or RF chokes at various locations on the longer FSs **9** or sections of the lead **3** that extend between CSMs **8**, or between electrodes or an electronic device and a CSM, or on a shield where this is included in embodiments noted above. *See*, Atalar et al., U.S. Patent No. 6,284,971, entitled, *Enhanced Safety Coaxial Cables*, the contents of which is hereby incorporated by reference as if recited in full herein. *See also*, Ladd et al., *Reduction of resonant RF heating in intravascular catheters using coaxial chokes*, Magn Reson Med 2000; 43(4): 615-619. *See also*, PCT Application Serial No., PCT/US2005/028116, filed August 9, 2005, entitled, *Implantable MRI Compatible Stimulation Leads and Antennas and Related Systems and Methods*, the contents of which are hereby incorporated by reference as if recited in full herein. Generally stated, this co-pending application describes incorporating RF chokes on (DBS and CP) lead systems, and again would be applied in embodiments herein to the longer FSs or portions of lead **3** that extend between CSMS, or between electrodes or an electronic device and a CSM, or on a shield where this is included as above.

[0178] Some physical and electrical parameters or characteristics of the conductor **3** and/or FS **9** and BS **10** with modules **8** incorporated in the leads **20** include:

1) Physical lengths of each current suppression module **8** of a conductor between about 1 cm to 3 m long, but typically about 4 cm to about 10 cm.

- 2) Numbers of CSMs per conductor: typically between about 1-100, and more typically between about 1-25.
- 3) Transverse spacing of each or some CSMs of a respective conductor can be between about 0.1 mm to about 20 cm, and typically between about 1 cm to about 9 cm.
- 4) RF impedance of a CSM can be any suitable value, from low impedance to high impedance, such as above about 5 ohms, typically > 20 ohms, and in some embodiments about 100 Ohms or greater along the length of a respective CSM at RF frequencies of interest.
- 5) Overall RF impedance of the conductor and/or lead can be any suitable value, but, in some embodiments, can be about ≥ 100 ohms.
- 6) Low DC resistance (allowing for lower power requirements and/or longer battery life in some embodiments).
- 7) Cross-sectional width, typically diameter, of the conductor(s): 0.0001 inches to about 0.5 inches, typically between about 0.001 to about 0.2 inches, and more typically between about 0.002 inches to about 0.1 inches. One or more of the conductor(s) can be insulated and/or insulated and shielded.
- 8) The conductors may be circular, flat, rectangular, square or elliptical or other shape in cross-section. The insulator, where used, can be conformal so that when they are applied to the conductor, does not change the shape.
- 9) The conductors can comprise any MR and biocompatible material, including, for example, Au, Ag, Nitinol, Ti, Pt, Ir or alloys thereof, MP35N, SST, DFT (drawn filled tube, typically with a MP35N outer layer and a conductive (metallic) core such as a silver core).
- 10) The conductors can be insulated by biocompatible materials such as, for example, Teflon, Nylon, polymers, PTFE, ETFE, silicone, polyurethane, PEEK (poly ether ethyl ketone), and/or epoxy, which also act as dielectric material distributed between the various conducting section in the leads.

[0179] **Figures 21A, 21B, 21C and 22A, 22B, 22C** are examples of leads **20** comprised of stacked multi-layers **8m** forming the CSMs **8** of conductor **3**. **Figure 23** shows a lead **20** with at least one conductor **3** formed with a plurality of CSMs **8** spaced apart in a lengthwise or longitudinal direction.

[0180] In particular, **Figure 21A** illustrates a tri-layer configuration with three coiled segments closely stacked over each other, with a first inner layer coil **16** as a FS **9c**, an intermediate second layer coiled back section **17 (10c)** and a third outer layer coiled forward section **18 (9c)**. **Figure 21B** illustrates a single conductor triple stacked or tri-layer configuration **8m** while **Figure 21C** illustrates a two conductor **3₁, 3₂**, triple stacked configuration **8m**. As shown in **Figures 21A-21C**, the outer coil **18** and inner coil **16** can form two FS **9 (9₁, 9₂)** and the intermediate coil **17** can be a BS **10**. For leads with more than one conductor **3_n** (where $n > 1$), two or more of the conductors **3_n** can be cowound to form the three layers, analogous to **Figure 9**, as shown, for example, in **Figure 21C** which illustrates a two conductor **3₁, 3₂** stacked CSM configuration **8-2**. For a three (or more layer configuration), the first layer **16 (8i)** can be wound from left to right (distal to proximal end of the lead), the second layer **17 (8k)** can be wound over the first layer and is wound right to left (from proximal to distal end of the lead), the final layer **18 (8o)** on the top of the two can be wound left to right (distal to proximal end of the lead) and may have the same or smaller (*e.g.*, closer) pitch than the first two layers. In this embodiment (stacked three-layer), all the layers **16, 17, 18** can be coiled maintaining the same rotation direction (CW or CCW) for the coil winding equipment. A fourth or additional layers can be stacked on the third layer **18** (not shown).

[0181] **Figure 21D** illustrates a single conductor **3** in a tri-layer stacked configuration **16, 17, 18** (with each successive coil on a different but closely abutting over layer) held about an integral flexible inner sleeve **190**, which may define an open lumen (not shown). As shown, at least one end portion of the conductor **3_p** (*e.g.*, the proximal end) can be configured so that the last or first CSM **8** merges into a wider pitch coil **3_w** for a number of revolutions, such as, for example, 3-10 revolutions. As also shown, a relatively short outer sleeve **199** can be placed over a portion of the CSM **8** as well as the coils **3_w** to help hold the conductor **3** in position/shape before the outer layer is placed thereon (*e.g.*, by molding or other suitable method). The short outer sleeve **199** length can vary, but in some embodiments can be between about 0.5 cm to about 2 cm long.

[0182] **Figures 22B** and **22C** also illustrate a two-layer multi-stacked CSM **8m**, with **Figure 22B** illustrating a single conductor CSM **8** and **Figure 22C** illustrating a two conductor **3₁, 3₂** CSM **8-2**. As shown, the inner layer **8i** includes

one FS 9c and one BS 10c, which reside under the other FS 9c formed as the outer CSM layer 8o.

[0183] Figures 22D-22F illustrate a portion of a lead 20 with a two-conductor 8-2, double stacked CSM 8. Figures 22D and 22F show the top layer 8o in section view to illustrate the underlying layer 8i of the pattern of the two conductors 3₁, 3₂. As shown in Figure 22F, the conductors 3₁, 3₂ change rotational direction once at an end portion 33 of a respective CSM 8. Figure 22E illustrates that a short length of a sleeve (such as a PET heat shrink tube) 199 can be placed over the end portion of the CSM 33 at at least one end of the lead and a few revolutions of the conductors 3₁, 3₂ proximate thereto to hold the conductors in position against the sleeve 190 and/or mandrel 190m. In addition, a small amount of UV adhesive or other suitable adhesive (or other temporary or permanent attachment means) can be placed on the conductors 3₁, 3₂ and/or sleeve 190 at position 33 to help hold the conductors in position prior to winding the next CSM 8. Other inner diameter sleeves/tubes can be positioned at different locations to help hold the conductor(s) in position, such as for attaching one or more electrodes/sensors or transducers to the lead body (not shown).

[0184] In some embodiments, the leads are multi-conductor leads 20, such as, for example, but not limited to, leads having between about 2-100 conductors 3, typically between about 2-50 conductors 3, and more typically between about 3-16 conductors and some or all of the conductors 3 can be wound side-by-side in a substantially flat or level first layer in a first direction (*e.g.*, front to back or right to left direction).

[0185] In some embodiments, the co-wound conductors can then be wound to form a second layer interleaved with and/or over the first layer, then wound to form at least a third layer (or even more layers), again with the third layer interleaved with and/or above the first and/or second layer. Depending on the crossover of the conductors as the conductors 3 transition to the different lengthwise directions, the second and third layers (or additional layers where used) may have a varying diameter, but the layers may be substantially concentric with each other.

[0186] Each coil within a CSM 8 can have a different pitch or some or even all of the coils in a single CSM 8 can have substantially the same pitch. In some embodiments, the first layer coil(s) can have a wider (lower) pitch and one or more of

the overlying coil(s) can have a closer/ more narrow (greater) pitch. Each layer of one or more coils of a respective conductor(s) can have a relatively thin thickness corresponding to the size of the conductor (with insulation), such as between about 0.0001 inches to about 0.2 inches. In some embodiments, each layer has a thickness of about 0.001 inches to about 0.006, such as, for example about .0026 inches, for a total thickness of the lead being less than about .20 inches (depending on the thickness of the outer encasement layer), such as, for example, between about 0.015 to .020 inches.

[0187] The different closely spaced and/or stacked coiled sub-portions of a single conductor **3** can be wound with the same or different pitches to form a CSM **8** and/or a CSM as well as the leading portion of the next, neighboring CSM **8** and/or a bridge to the next neighboring CSM **8**.

[0188] In some particular embodiments, the different CSMs **8** of a respective conductor **3** can optionally be formed using multiple lengths of discrete conductors attached together, rather than a single continuous length of conductor.

[0189] For a continuous length conductor, the windings can be substantially continuous along a length of a respective conductor (or, where used, multiple conductors co-wound during the same winding set-up) and can be formed by substantially continuously or intermittently winding a respective conductor using an automated coil winder, such as, for example, an Accuwinder Model 16B, available from Accuwinder Engineering Co. having a place of business at San Dimas, CA.

[0190] A lead incorporating multiple CSMs **8** (as illustrated in **Figure 23**) was prototyped and tested with two 0.007" diameter 35N LT -DFT conductors (*e.g.*, wires/filars) with silver core (19 filar cable, 0.005" conductor OD and 0.001" wall ETFE insulation), with the conductors (*e.g.*, wires/filars) cowound parallel to each other and coiled in three layers. The first layer (coiled forward section) has an inner diameter of 0.023", the second layer (coiled back section) is coiled over the first and the third final layer (coiled forward section) is over the first and the second layers. This CSM had an impedance of over 200 ohms at 64 MHz and length of 4.7 cm. The winding details are listed in **Table 1** below.

TABLE 1: EXEMPLARY TRI-LAYER CSM

Layer #	Winding Direction	Direction of rotation	Pitch	Length
Layer #1	Left to Right	Clockwise	0.050"	4.7 cm
Layer #2	Right to left	Clockwise	0.050"	4.7 cm
Layer #3	Left to Right	Clockwise	0.020"	4.7 cm

The impedance of the 4.7 cm CSM section is shown in **Figure 24A**. **Figure 24B** shows one example of a technique that can be used to measure impedance of a multi-conductor configuration (the measurement may be different for different CSM configurations). As shown, the measurement probe can be connected to different conductors of the device, taking care to connect the same conductor on each end of the device to be measured (*e.g.*, conductor 2 of 4) and connect this conductor to the measurement probe shield and core. The network analyzer can be calibrated to the end of the measurement probe and the impedance can be measured when loaded in a saline solution. A two conductor, 62 cm long lead, incorporating 12 cowound trilayer CSMs **8m** along the length of the lead, was heat tested in 1.5T (64 MHz) and 3T (128 MHz) MRI scanners in an acrylamide gel phantom. The change in temperature (ΔT) in the gel (simulating tissue) adjacent to the electrodes as measured to be less than 2°C with a 4.3 W/kg peak input SAR, as shown in **Figures 25A and 25B**.

[0191] **Figure 22A** is a two-layer coil stack configuration of a conductor **3** where one or more conductors are wound/cowound in forward-back-forward sections. As shown, two coils **16, 17** are on the same layer adjacent and interleaved with each other and the other coil **18** resides over the inner layer. Typically the BS **10** is coiled in the pitch of the first FS **9₁** on the first layer and the second FS **9₂** is longer and extends over the BS **10** and FS **9₁**. The first forward and back sections **16 (9c)** and **17 (10c)** are wound such that these do not overlap, and the back section **17 (10c)** fits in the pitch (gap) of the forward section **16**. This can be formed by attaching the proximal end of the conductors to a coiling mandrel or sleeve thereon and switching the rotational direction of the winding (left to right CW, right to left CCW, then left to right CCW or vice versa). The final forward section **18 (9c)** is coiled in the same direction of the back section and over the first forward and back section. The attaching can be adhesively and/or mechanically carried out.

[0192] **Figure 22B** illustrates a single conductor **3** configuration of a double stack **8m** with both the inner coil FS **9c** and the BS coil **10c** being inside the

second layer **8o** with coil FS **9c**. **Figure 22C** illustrates two conductors **3₁**, **3₂** coiled to form a two-conductor **8-2** double stack CSM **8m** with the inner layer **8i** having both a FS and BS **9c**, **10c**, respectively, and the outer layer **8o** having a FS **9c**.

[0193] As discussed above with respect to **Figure 21D**, **Figures 22D-F** also illustrates the optional flexible sleeve **190** (*e.g.*, a biocompatible flexible sleeve). The sleeve **190** is typically placed over the coiling mandrel during fabrication and can remain as an integral part of the lead **20** while the mandrel is typically removed. Other sized sleeves can be used. The sleeve **190** outer diameter is typically sized to provide the desired diameter of the lead (taking into account the outer diameter of the lead will also correspond to the number of stacked layers as well as the outer over encasement or overlayer that defines a substantially constant outer diameter). The sleeve **190** typically has a continuous closed outer wall, but may be discontinuous and/or have open pores or apertures. In some embodiments, the sleeve **190** is biocompatible can comprise any suitable material, typically a polymer such as PTFE or Nylon (such as Vestamid® L2140), and can have any suitable size, such as, but not limited to, an outer diameter of between about 0.01 inches to about 0.1 inches, typically between about .01 to about .05 inches, more typically about 0.024 inches, a wall thickness of between about 0.001 inches to about 0.02 inches, and can include a through lumen inner diameter of between about 0.001 inches to about 0.025 inches, typically between about 0.010 to about 0.02 inches, such as about 0.014 inches. The lead **20** can be configured so that the MCSMs extend substantially the entire length of the conductor as a series of continuous coils of adjacent CSMs. The leads **20** can be connected to electrodes and be bipolar for some cardiac applications. A distal and/or proximal end of the lead may include a short length of straight or single layer coil that connects to an electrode. To aid in maintaining coiled CSMs in position or to inhibit unwinding/movement of a coil, a small piece or length of heat-shrink tubing (*e.g.*, about 10 mm or less of PET heat shrink tubing) can optionally be placed at different conductor coil segments and heated to compress the conductor against the liner/mandrel to hold the conductor in position.

[0194] In addition, in some particular embodiments, the third layer can be formed so that most of the revolutions are at a tight pitch, *e.g.*, 78 revolutions at a pitch of about 0.2 in to end at a few last revolutions, *e.g.*, 5-15 revolutions at a larger pitch such as about 0.7 in for easier electrode installation/connection.

[0195] A lead 20 incorporating this **Figure 22A CSM 8** design was prototyped and tested with two 0.007" diameter DFT conductors (with insulation), e.g., wires/filars with silver core, 19 filar cable, 0.005" cable OD and 0.001" wall ETFE insulation, with conductors cowound parallel to each other and coiled in two layers. The first layer (coiled forward section) has an inner diameter of 0.023" and a pitch of 0.05", the second layer (coiled back section) is coiled in the space/pitch of the first layer; and the third final layer (coiled forward section) is on/over the first and the second layers. This CSM had an impedance of over 200 ohms at 64 MHz and length of between about 5 cm and 5.7 cm. The details of the windings are as listed in **Table II** below.

TABLE II: EXEMPLARY TWO-LAYER CSM

Layer #	Winding Direction	Direction of rotation	Pitch	Length	Comments
Winding #1	Left to Right	Clockwise (CW)	0.050"	5.7 cm	Layer # 1
Winding #2	Right to left	Counter Clockwise (CCW)	0.050"	5.7 cm	Layer # 1
Winding #3	Left to Right	Counter Clockwise (CCW)	0.020"	5.7 cm	Layer # 2

To form the next adjacent CSM, the winding can continue in the CCW direction (left to right) and the backward section can be coiled in the CW direction (right to left), followed by the other forward section also in the CW direction (left to right). That is, the conductor changes the coiling rotation direction once per CSM and each adjacent CSM alternates the rotation direction of the different FS, BS, FS segments (e.g., CSM module one, CW, CCW, CCW, CSM module two, CCW, CW, CW, module 3, CW, CCW, CCW...). As the conductor 3 exits the upper forward section it continues on to form the lower forward section of the next adjacent CSM 8.

[0196] The electrical impedance of this 5.7 cm CSM 8 is shown in **Figure 26**. A lead 62 cm long incorporating 11 CSMs 8 along the length of the lead 20 (analogous to **Figure 23**) was prototyped and tested. Heat test results from this lead show less than 2°C temperature rise in the simulated tissue (gel) adjacent to the electrodes in 1.5T field strength MRI scanner with 4.3 W/kg peak input SAR (**Figure 27**).

[0197] **Figures 28A and 28B** are schematic cross-sectional views of a conductor **3** in the plane of its long axis with a multi-layer coiled CSM configuration **8m**. **Figure 28A** corresponds to the first layer of a two-layer configuration such as that shown in **Figure 22A**. **Figure 28B** corresponds to the three separate layers of a three-layer configuration such as shown in **Figure 21A**.

[0198] **Figures 29A and 29B** are enlarged digital images of a multi-conductor lead **20** having conductors **3** in substantially continuously arranged triple stacked layers of coils forming a CSM **8m** according to embodiments of the present invention. **Figure 29B** illustrates an outer encasement layer that defines a substantially constant outer diameter over the flexible lead with the stacked CSMs **8m**. **Figures 29C and 29D** are digital images of an enlarged multi-conductor lead **20** having conductors **3** in substantially continuously arranged double stacked layers of coils forming a CSM **8m** according to embodiments of the present invention. **Figure 29D** illustrates an outer encasement layer that defines a substantially constant outer diameter over the flexible lead with the stacked CSMs **8m**.

[0199] The exemplary coil diameters, coil lengths, and conductor lengths can have a significant range of values within the scope of the invention, typically with a primary design parameter being that of wavelength noted above. While embodiments of the invention have been illustrated in the context of MRI exposure at 64 MHz (1.5T MRI) and 128 MHz (3T MRI), it is intended that applications of the present invention to MRI shall include MRI over the full range of RF afforded by MRI scanners, including, for example, 0.1, 0.3, 0.7, 1.0, 1.5, 2.5, 3, 4, 4.7, 7 and 9.4 Tesla (T) systems, especially commercially available scanners such as, 1.5T scanners, 3T scanners (128 MHz), 1T scanners (42 MHz), 0.5T scanners (21 MHz), 4T (170 MHz) and 7T (300 MHz) scanners.

[0200] It is also contemplated and included in the present invention that embodiments involving implanted leads include the use of biocompatible materials and/or coatings, and the conductors **3** include aluminum, gold, silver, platinum, rhodium, iridium, rare earth metals, alloys of these and other conducting metals including Nickel Titanium alloys (*e.g.*, nitinol, MP35N, etc.), and conductors formed from coatings of metals, for example, gold coated nitinol, or nitinol or MP35N, etc. with a silver or Pt core, etc., such as, for example drawn tubing formed of MP35N available from Ft. Wayne Industries located in Ft. Wayne, IN, USA.

[0201] For implantable leads 20, the designs can be configured to have the mechano-chemical properties of flexibility, strength, durability, resistance to fatigue, non-corrodible, non-toxic, non-absorbent, and bio-compatible and/or bio-inert. It is further contemplated that embodiments of the invention can be used in any of a range of applications where implanted conducting leads (or external or combinations of same) are required, including but not limited to: connections to IPGs, DBS electrodes, cardiac pacemakers, cardiac electrodes, nerve stimulators, electrodes, EEG and EKG monitors (devices with either or both internal and external leads), cardiac defibrillators, power sources and/or control lines for artificial limbs, power sources and/or control lines for artificial organs (kidneys, etc); power sources and/or control lines for implanted bio-substrates or enzyme delivery devices (e.g., insulin delivery) or other drug delivery devices, and the like.

[0202] **Figure 30A** is a schematic illustration of a DBS system with at least one lead (typically two leads) with CSMs 8 and an IPG and electrodes 4 according to some embodiments of the present invention. Optionally, as shown in **Figure 30A**, the proximal portion of the lead 20e can be reinforced and/or larger (thicker) than the distal portion. This larger portion 20e can be integral on a single lead or may be provided as a matable/connecting lead extension. The proximal end portion 20e can have a length of between about 2-15 cm, typically between about 5-10 cm. The larger portion/extension 20e can provide increased fatigue or torque resistance or other structural reinforcement proximate a rigid body, such as, for example, an IPG. The proximal portion or lead extension 20e can include one or more CSMs 8 or may not include any CSMs 8. Alternatively, the lead extension 20e may include a differently configured CSM 8 and/or a less dense CSM arrangement (less CSMs per cm) relative to the distal portion of the lead 20. **Figures 30B** and **30C** are schematic illustrations of therapeutic systems (medical devices) with leads connected to a cardiac pulse generator. **Figure 30B** illustrates the system can include two leads, extending to the right auricle (RA) and right ventricle (RV), respectively, while **Figure 30C** illustrates that the cardiac system can have three leads (one each in the RV, RA and left ventricle, LV). **Figure 30B** also illustrates that the distal end portion of the lead 20e may have a larger (thicker) and/or reinforced configuration relative to the more flexible distal end portion as discussed with respect to **Figure**

30A. Again, the proximal end 20e can have a length between about 2-15 cm, typically between about 5-10 cm.

[0203] **Figure 30D** schematically illustrates that the lead system **20** interconnects two electronic devices **50₁**, **50₂** residing either inside or external to a human or animal body. In some embodiments, the devices can be non-medical devices, such as communication devices. In other embodiments the devices can be medical devices. For example, at least one end portion of the at least one conductor **3** connects an electrocardiographic electrode **50₁** and at least another end is connected to an electrocardiographic monitoring device **50₂**. In other embodiments, at least one end portion of the at least one conductor **3** is connected to an electroencephalographic electrode **50₁** and at least another end is connected to an electroencephalographic monitoring device **50₂**. In still other embodiments, at least one end portion of the at least one conductor **3** is connected to a blood pressure monitoring transducer **50₁** and at least another end is connected to a blood pressure monitoring device **50₂**. In yet other embodiments, at least one end portion of the at least one conductor **3** is connected to a blood oxygen monitoring transducer **50₁** and at least another end is connected to a blood oxygen monitoring device **50₂**.

[0204] **Figure 30E** is a schematic illustration of an MR Scanner **500** with a high-field magnet bore **500b**. In some embodiments, the lead **20** can be configured to extend inside the bore **500b** during some interventional or diagnostic procedures. The lead **20** can be a cable, extension or guide that manipulates a device such as a robotic or remotely operated tool or other device. The lead **20** can connect an external control unit **50₁** to an adjustable or moveable component or tool **50₂** inside the magnet bore **500b**. The lead **20** can be torqueable, *e.g.*, rotate to turn or manipulate input or surgical devices or tools. The lead **20** can include at least one cable or conductor with at least one CSM **8** with a respective at least one FS and BS **9, 10**. **Figure 30F** illustrates that the tool **50₂** can be an adjustable trajectory frameless head mount **510** that can be used to adjust the trajectory of the implantable lead to place and implant DBS leads using MR guidance while the patient remains in the magnet bore **500b**. **Figure 30G** is an example of one surgical tool, a frameless head mount **510**, with cables or leads **20** configured with at least one CSM **8** according to embodiments of the present invention.

[0205] Described below are exemplary designs that can be implemented on any lead, including, for example, cardiac leads, such as bradyarrhythmia and tachyarrhythmia or ICD lead systems. Although shown with electrodes, the configurations can be used with other elements or with just a lead or cable, as appropriate to the application. The RF/MRI safe leads **20** can include one or more conductors **3** of the lead arranged in multiple CSMs **8** where each CSM has a length of between about 1.5 cm to about 6 cm, and each CSM **8** is arranged such that it has impedance exceeding about 100 ohms at target MRI frequencies (for example, 128 and 64 MHz).

[0206] **Figures 31A, 31B, 32A and 32B** are schematic illustrations of leads that are described as particularly suitable for bradyarrhythmia and tachyarrhythmia or ICD lead systems, for which it is desirable to render MRI-safe and/or RF safe, according to embodiments of the present invention. These leads and/or features thereof can be modified to fit other applications as well. The leads **20** may include different tissue fixation configurations such as, for example, passive fixation or active fixation. In passive fixation the distal end of the lead is anchored in the folds of the cardiac tissue. In active fixation, the distal end of the lead is a helical screw, which is fixed in the cardiac tissue.

[0207] Bradyarrhythmia leads or pacemaker leads (**Figure 31A, 31B**) typically have two electrodes **4**, a distal pacing and sensing electrode **31**, and the proximal ground electrode **33**. The conductors **3** connecting the distal electrodes **31** and **33** to IPG contact electrodes **35** and **36**, are typically cowound/coiled along the length of the lead **20**. In passive fixation leads, the distal electrode **31** may be a conductive contact; whereas in active fixation leads this contact can be a helical screw **37** which can be torqued and turned by turning the proximal end of the coiled conductor via electrode **36**.

[0208] Tachyarrhythmia leads (**Figure 32A and 32B**) typically have three electrodes; distal pacing and sensing electrode **31**, and two proximal shocking electrodes **38** and **40**. The conductor **3** connecting the distal electrode is coiled along the length of the lead, and is in the center of the lead. The shocking coils are cowound coils of non-insulated conductors, and are connected to the proximal electrodes/IPG by conductors **39** and **41**.

[0209] Now in accordance with embodiments of the present invention, conducting leads of the tachyarrhythmia, bradyarrhythmia, ICD (implantable cardio-defibrillator) and/or pacing lead system may be formed with CSMs 8 or with CSMs and shield elements to suppress induced RF currents and improve the safety of such devices during MRI, as exemplified in **Figures 33-44** and **Figures 55A-58B**. Thus, **Figure 33** illustrates a lead 20 with a passive fixation bradyarrhythmia lead design with two conductors 3₁, 3₂, each conductor is wound in CSMs 8 and arranged along the length of the lead one conductor 3₁, alternating the other 3₂. Each conductor has CSMs 8 formed along the length and spaced intermittently. When the lead is assembled, the CSMs of each conductor are interleaved/alternated along the length of the lead. The straight sections of the conductors will typically overlap the CSMs of other conductors. Conductors 3₂ and 3₁ connecting to the distal electrode 4 and distal ground electrode 31, respectively, are wound in CSMs 8 which are spaced apart from each other. When the lead 20 is assembled, the CSMs 8 of the two conductors 3₁, 3₂, alternate.

[0210] **Figures 34** and **35** show embodiments with two conductors 3₁, 3₂, with multiple CSMs 8 along the length of the lead 20; with one conductor 3₁ CSM assembly substantially concentric to the other 3₂. The CSMs 8 of the conductors 3₁, 3₂, have inner and outer diameters such that they can be concentrically arranged along the length of the lead. One conductor CSM assembly, for conductor 3₂ can rotate with respect to the other, *i.e.* in CSM assembly for conductor 3₁. The CSMs 8 of the conductors 3₂ and 3₁ have inner and outer diameters such that they can be concentrically arranged along the length of the lead. One conductor 8 CSM 3₂ assembly can rotate with respect to the other 3₁. The center conductor CSM assembly 3₂ is connected to the fixation helix 37 at the distal end. The fixation helix 37 can be manipulated by torquing the center conductor CSM assembly 3₂ and this in turn rotates and laterally slides the fixation helix 37 in and out of the lead 20 allowing anchoring in the cardiac tissue.

[0211] **Figure 36** shows a passive fixation bradyarrhythmia lead embodiment with distal electrode conductor 3 wound in trilayer CSMs 8m along the length of the lead and is in the center of the lead 20. The proximal connector is connected to the IPG by means of a RF high impedance shield layer 48 with RF traps 49 and the shield layer can shield the inner conductor 3 and CSM 8m thereof. The

conductor **3₁** connecting to the distal electrode may be arranged along the length to have one or more CSMs. The conductor **3₂** connecting the proximal electrode is a high impedance shield **48** incorporating RF traps **49** along the length of the shield. The impedance of the RF trap can typically exceed about 300 ohms and one or more traps can be placed along the length of the lead.

[0212] **Figure 37** shows an embodiment of the invention in an active fixation bradyarrhythmia lead **20** with distal electrode conductor **3₁** wound in trilayer CSMs **8m** along the length of the lead and is in the center of the lead, and this conductor **3₁** can rotate freely with respect to (WRT) the lead body. The proximal electrode conductor **3₂** is arranged in CSMs **8** and is substantially concentrically outside the distal electrode conductor **3₁**.

[0213] **Figure 38** shows an active fixation bradyarrhythmia lead **20** with distal electrode conductor **3₁** wound in trilayer CSMs **8m** along the length of the lead and is in the center of the lead, and rotates freely WRT the lead body. The proximal electrode conductor **3₂** is arranged as an RF trap **49** along the length of the lead and can provide a shield **49** for the inner conductor **3₁**. The center conductor CSM assembly **3₁** is connected to a helical fixation screw **37** at the distal end. The proximal electrode is connected to the IPG via a high impedance shield **48** with RF traps **49** as discussed with respect to **Figure 37**. The inner conductor assembly **3₁** can be rotated WRT the outer shield **49**, by rotating the proximal electrode. This also rotates and drives the fixation screw **37** laterally, thus anchoring in the cardiac tissue.

[0214] **Figure 39** illustrates another (passive fixation) tachyarrhythmia lead **20** where three conductors **3₁, 3₂, 3₃** are cowound to form CSMs **8**. One is connected to the sensing electrode **40**, other two to the shocking electrodes **4 (38)**. The three conductors **3₁, 3₂** and **3₃** are cowound and multiple CSMs **8** along the length in the proximal section, in the mid section (between two stimulation electrodes **38** and **40**) two conductors **3₃** and **3₂** are cowound to form some CSMs **8**, and in the distal part only the distal electrode conductor **3₂** is arranged to form CSMs **8**.

[0215] **Figure 40** illustrates a (passive fixation) tachyarrhythmia lead where the three conductors **3₁, 3₂, 3₃** are arranged to have CSMs **8** along the length of the lead **20** and the three conductors **3₁, 3₂, 3₃** alternate CSM **8** locations along the length of the lead. CSMs **8** are placed discontinuously or intermittently along the length of each conductor **3**. In the distal section the sensing electrode conductor and

the distal shocking electrode conductor **3₂**, **3₃**, respectively, are alternated, in the proximal section the CSMs **8** on all the three conductors **3₁**, **3₂**, **3₃** are alternated. This design may reduce the coupling of the distal electrode conductor **3₃** with the stimulation or shocking conductors **3₁**, **3₂** during the shock-defibrillation operation of the ICD.

[0216] **Figure 41** shows a (passive fixation) tachyarrhythmia lead **20** where the three conductors **3₁**, **3₂**, **3₃** are arranged to have CSMs **8** along the length of the lead **20** and the distal electrode conductor **3₁** is in the center of the lead and concentric to the shocking electrode conductors **3₂**, **3₃**. This design may reduce the coupling of the distal electrode conductor with the shocking conductors during the shocking operation of the ICD.

[0217] **Figure 42** illustrates a (passive fixation) tachyarrhythmia lead **20** where the distal electrode conductor **3₁** is arranged to have CSMs **8** along the length of the lead **20** and the shocking electrode conductors are straight along the length of the lead.

[0218] **Figure 43** illustrates an active fixation tachyarrhythmia lead **20** where the distal electrode conductor **3₁** is arranged to have CSMs **8** along the length of the lead **20** and the stimulation/shocking electrode conductors **3₂**, **3₃** are substantially straight along the length of the lead **20**.

[0219] **Figure 44** shows an active fixation tachyarrhythmia lead **20** where the distal electrode conductor **3₁** is arranged to have CSMs **8** along the length of the lead **20** and the shocking electrode conductors **3₂**, **3₃** are arranged so as to have CSMs **8** along the length of the lead.

[0220] In some embodiments, the cardiac leads can be configured with shocking electrodes used in ICD leads, the conventional shocking electrodes, which are conventionally 4-5 cm long and comprise a wound conductor may need modification for MRI compatibility. This conductor may be longer than $\lambda/4$ at MRI frequencies and may add to temperature rise in the tissue adjacent to the coils. The shocking coils can be electrically reduced in length and this may be achieved by using a flexible stent-like design instead of a coil, *e.g.*, using a sinusoidal helix where one segment is interconnected with other so as to reduce the electrical length of the shocking electrode.

[0221] In particular embodiments, every or some alternate CSMs **8** may be wound in opposite directions to suppress currents induced in the lead by alternating magnetic fields and potential nerve stimulation.

[0222] The conductor configurations can be used for any lead used during an interventional procedure and/or for any medical device, whether implantable or not and whether for chronic or acute use.

[0223] **Figures 55A and 55B** illustrate a distal end portion of a lead **20** suitable for a passive fixation pacemaker lead. As shown, the CSM **8** is a triple stacked CSM **8m** having two-conductors CSM **8** with coils in three layers **8i**, **8k** and **8o**. The FS **9c** are the inner and outer layers **8i**, **8o** and the BS **10** is in between the two FS **9c** in layer **8k**. The lead **20** can include one or more electrodes **31** and a fixation barb **34**. As shown, an outer layer **21** of a suitable biocompatible material can be formed over the CSMs **8** to define a substantially constant outer diameter.

[0224] **Figures 56A and 56B** illustrate a distal portion of a lead **20** that may be particularly suitable for a passive fixation ICD lead. As shown, the lead **20** includes both a two-conductor **8-2** and a three-conductor **8-3** CSM **8** (both in a triple-stack configuration). The three conductor CSM **8-3** resides upstream of the two-conductor CSM **8-2** which merges into the tip electrode **31t**.

[0225] **Figures 57A and 57B** illustrate another lead **20** which may be particularly suitable for an active fixation pacemaker lead. As shown, the distal tip of the lead **20t** can comprise a screw electrode **31s** that merges into an expansion spring **135** in communication with a single inner conductor **3i** having one or more CSMs **8** (as shown, the inner conductor **3i** has a triple-stacked CSM configuration). The lead **20** includes an inner sleeve **80** over the inner conductor **3i** and an outer sleeve **85** over the inner sleeve. One or more CSMs can reside over the inner sleeve **85**. As shown, a single outer conductor **3o** can be configured in one or more outer triple stacked CSM configurations **8-1o** that merges into electrode **31**. The inner conductor **3i** is configured with one or more inner CSM configurations **8-1i** and can rotate and/or translate with respect to the outer sleeve **85** to extend the screw electrode **31s** out of a lumen defined by the lead. In particular embodiments, the inner sleeve **80** can be a PET shrink sleeve compressed against the inner conductor **3i**. The outer sleeve **85** can be a FEP sleeve or other suitable biocompatible material that is bonded or otherwise held to the outer sleeve **85**. The lead **20** can include an outer layer **21** over

the outer conductor(s)/CSMs **8**. A nut **131** can be attached to the distal end of the sleeve **85**. Although shown as single conductor outer and inner CSM configurations and illustrated as a triple stack CSM **8**, both the inner and outer conductor configurations can be a plurality of conductors and the CSMs can be formed in other CSM configurations as described herein with respect to other figures.

[0226] **Figures 58A and 58B** illustrate another lead **20** which may be particularly suitable for an active fixation ICD lead. This embodiment is similar to that described with respect to **Figures 57A and 57B**, but the lead includes outer two-conductor CSMs **8-2** formed as a triple stack configurations **8m** that merge into a single-conductor CSM **8-1o** also formed as a triple stack configuration **8m**. The two-conductor CSM **8-2o** extends to a first electrode **31** and the single CSM **8-1o** extends to the next upstream electrode **31**. Again, different numbers of conductors and different arrangements or CSM configurations can also be used to form the ICD lead.

[0227] **Figures 45-53** describe methods of fabricating devices and associated fabrication systems or apparatus according to the present invention. Thus, **Figures 45A-45E** illustrate two conductors being cowound on a coiling mandrel to form the stacked trilayer CSM **8m** (*see, e.g., Figure 21A*). A copper wire or other suitable material elongate substrate, typically but optionally, covered with a tube or sleeve can form the mandrel. **Figures 46A-46F** illustrate a two-layer stacked CSM **8m** conductor design during fabrication (*see, e.g., Figure 22A*). The coil winder and/or conductors **3** are shown moving back and forth on the mandrel to coil the conductors in the forward and reverse directions (*see, e.g., Tables I and II* above).

[0228] **Figures 47A-47C** show a coiled conductor lead subassembly before an overmolded flexible layer is formed thereover. **Figures 48A-48D** illustrate that the subassembly can be placed in a mold and a material directed therein (shown as being injected when the mold is closed in **Figure 48B**). **Figure 48C and 48D** illustrate the molded lead after the mold lid is removed. **Figure 49** illustrates a resultant flexible overmolded lead **20**.

[0229] **Figures 50-52** illustrate an exemplary mold **100** used to form the flexible lead **20**. The mold **100** is sized and configured to receive the lead subassembly **20s** with the coiled conductor(s) **30**. The mold has a top and bottom **101, 102** which together form a shallow mold cavity **103** that is sized and configured to receive the subassembly **20s**. A spacer **120** can optionally be placed over the

subassembly 20s to snugly position the subassembly in the cavity 103 to inhibit the lead subassembly from moving during introduction of a desired moldable material, such as a flowable polymer, that will form the polymer skin or encasement of the lead 20. Movement of the relatively long flexible conductor (wire(s)) may cause varying or a non-uniform thickness in the outer layer and/or skin. The spacer 120 can be a spiral wrap can be placed about the subassembly 20s. The spiral wrap 120 can be configured to allow the molded outer layer to form on the subassembly without affecting the thickness of the skin or outer layer. The spiral wrap 120 can be formed using a silicone tape and/or an application of semi-solid flexible silicone, polyurethane, epoxy or other polymer, co-polymer or derivatives thereof and/or combinations of same or other suitable material. Other spacer 120 configurations may also be used, such as, for example, discrete polymer geometrically shaped members such as pellets or balls and/or holding tabs rods or cones. Over-wrapping the subassembly before placement in the mold cavity 103 can allow the lead subassembly 20s to remain centered even during introduction of the flowable (*e.g.*, gelatinous or liquid) polymer. Suitable overmold layer materials include, but are not limited to, polymers (homopolymer, copolymer or derivatives thereof), silicone, polyurethane, Nylon, Teflon, ETFE, FEP and the like.

[0230] The mold 100 can include one or more open exit ports 105 (Figure 51) that may remain open during molding. The mandrel 300 (Figure 51 and 45a) used to coil the subassembly can be removed after the subassembly is molded by pulling from the end of the mold via port 105 (Figure 51). In other embodiments, the mandrel 300 can be held inside a flexible thin sleeve or tube during the winding. The sleeve can form an integral part of the subsequent lead. The mandrel can remain in position during the molding or pulled from the sleeve prior to inserting the subassembly (held on the sleeve) into the mold cavity 103 (Figure 52). The mandrel can be inserted into a PTFE tube (1/10 inch inner diameter) and/or be formed by a coated copper or SST wire or other suitable support device.

[0231] Referring to Figure 53 which describes exemplary operations that can be carried out in support of the fabrication process, the winding operations used to form stacked coils of CSMs can be carried out by winding a conductor on a mandrel to form a first coil in a forward lengthwise (or longitudinal) direction (*e.g.*, left to right) (block 200). The mandrel can be a wire held in tension during the winding

operation(s). After winding the first coil, the conductor can be wound over the mandrel to form a second closely spaced coil in a reverse lengthwise direction from the winding direction of the first coil (*e.g.*, right to left) (block **210**). The second coil can be formed all or partially over the first coil or all or partially next to the first coil on the same layer as the first coil in the gaps formed by the pitch of the first coil. Then, the conductor can be coiled in a third coil in the forward lengthwise direction (*e.g.*, left to right, the same longitudinal direction as the first coil) (block **220**). This can be repeated for a desired number of CSMs. Next an overmolded outer layer can be molded onto the conductor with the coils (block **230**). Optionally, the mandrel can be removed from the center of the stacked coils before, during or after the molding step (block **240**). In some embodiments the mandrel is placed in the mold with the lead subassembly and removed (pulled from the lead body) after about 10-30 minutes or longer (*e.g.*, 1-3 hours) after the polymer overcoat material is placed in the mold and the mold material heated or cured as desired.

[0232] The outer surface layer can have a substantially constant diameter formed over the stacked coils. Also, although some embodiments describe a two or three layer stacked-configuration, additional numbers of stacked layers may also be used, *e.g.*, four, five, six, seven, eight or even more by continuing the back and forth winding of the conductor.

[0233] Although the overmolding process has been described above, in other embodiments, other types of manufacturing processes can be used to form the biocompatible outer coating to form a suitable biocompatible substantially constant outer diameter (for at least a portion of the lead). In some embodiments, the outer diameter is not constant, but varies over the length of the lead at least one or more times. Examples of alternative outer layer forming processes include extrusion, injection molding and heated draw down. For example, in an extrusion tube, such as a silicone tube with an inner diameter that is smaller than the conductor winding can be expanded (such as, for example, using hexane). Once expanded, the wound conductor body can be placed inside the tube. As the hexane or other expander evaporates, the tube contracts to original size against the coil winding configuration. The electrodes (where used) can then be attached and an overlayer formed over them as appropriate, typically using liquid injection molding. Another alternative is the use of standard injection molding which may include silicone or a thermoplastic polymer

such as thermoplastic polyurethane (*e.g.*, Pellethane™) in standard injection molding equipment. Pellethane™ is available from Dow Chemicals, Inc.

[0234] Yet another process that may be used is heated drawdown. This process employs a heated die that is drawn across a thermoplastic extruded tube (such as Pellethane™), to cause the tube material to reflow. As the material reflows it is drawn down on the conductor winding body. The extruded tube can have a slightly larger inner diameter than the outer diameter of the conductor winding body and the conductor winding body is placed inside the tube. The assembly can then be loaded into a Drawdown machine such as one manufactured by Interface Associates of Laguna Niguel, CA. The inner diameter of the die (the final desired outer diameter of the lead) is smaller than the outer diameter of the tubing. The die is heated to a temperature that causes the thermoplastic material to flow. The die is drawn across the length of the conductor winding body causing the material to produce a smooth and substantially constant outer diameter over the length of the body.

[0235] In some embodiments, one part of the lead may be thicker than others. For example, a proximal portion of the lead may be reinforced to provide increased durability or fatigue resistance while at least the distal portion can be low profile with a smaller diameter or size. In other embodiments, a lead extension **20e** (**Figure 30B**) can extend between one lead and another lead or implantable or external component (*e.g.*, IPG).

[0236] The conductor(s) can be wound over the (thin) mandrel directly or via a sleeve over the mandrel (**block 205**). That is, rather than winding the conductor(s) to have a tight compressive force against the mandrel (or underlying sleeve), the coils can be formed to (directly or indirectly) contact the mandrel with a substantially constant force but with minimal compression.

[0237] The winding operations can be carried out to from two of the coils substantially on one layer and the other in another layer to form a two-layer stacked coil configuration (**block 215**). The first coil can be wound in a clockwise direction, the second in a counterclockwise direction, and the third in the counterclockwise direction (or the windings can be reversed, with the first coil in the CCW direction and the second and third in the CW direction) (**block 216**). Winding of the third coil on the upper or top layer can continue forward to form the first (lower) forward layer of the next adjacent coils. To facilitate the conductor remaining in position as the

winding transitions to the opposing winding direction, an end portion of the first coil can be held in position while the reverse rotational turning is initiated for the second coil. In some embodiments, the winding can be carried out using a conductor of about 0.007 inches O.D, with a starting winding O.D. (mandrel size) of about 0.023 inches. The conductor(s) can be wound for about 30-60 revolutions right (clockwise), typically about 32-45 revolutions, at a pitch of about 0.05 inches followed by about 30-60 revolutions left (with the winding changed to counterclockwise), typically about 32-45 revolutions, with the conductor falling into the gap in the first coil spacing over the mandrel, followed by winding greater than 60 revolutions to the right (counterclockwise), typically about 78-110 revolutions to the right, at a pitch of about 0.02 inches. In some particular embodiment, for a lead having a length of about 57.5 cm can have about 10 CSMs 8.

[0238] So, to form a double stack design, during the winding process, the conductor feed head direction changes direction and the coil wind direction also changes direction. Because the pitch of each of the first two layers is typically greater than about two times the conductor thickness and the coil wind direction is reversed, the first two layers sit substantially side-by-side. Other pitches and numbers of revolutions can be used to form the double-stack configurations. The winding operations can be repeated a plurality of times to form multiple CSMs 8 along a length of a lead (*e.g.*, MCSMs).

[0239] The winding operations can be carried out to stack the coils in three or more different stacked layers (*e.g.*, a tri-layer configuration) (block 212). The first and second coils can have substantially the same pitch and the third can have a smaller (closer) pitch (block 213). The first, second and third coils can all be wound in the same rotational direction (either one of the clockwise or counterclockwise directions) (block 214). The feed head serially changes directions three times to form the three coils (from forward to backward/reverse to forward again) but the rotational winding direction remains the same. In some embodiments, the winding or turning can be carried out using a conductor (*e.g.*, wire) of about 0.007 inches O.D, with a starting winding O.D. (mandrel size) of about 0.023 inches. The winding can be carried out by winding the conductor(s) about 20-60 revolutions in a first direction for the first layer, *e.g.*, right (clockwise) with a pitch of about 0.05 inches, typically about 32 to about 38 revolutions right, then winding about 20-60 revolutions in the opposite

direction for the second layer, *e.g.*, left at a pitch of about 0.05 inches, typically about 32 to about 38 revolutions left, then winding the third layer in the first direction again, *e.g.*, right, for between about 30-110 revolutions right, typically about 78-94 revolutions, at a pitch of about 0.02 inches. The third layer typically has an increased number of revolutions relative to the first and second layers.

[0240] The last CSM of the conductor can be fabricated so that the third layer coil terminates with a larger pitch that is larger than both the first, second and most of the third layer coils (*e.g.*, about .070 inches relative to the revolutions of the remainder of the layer which, in some embodiments is at about 0.20 inches). Some resulting multi-conductor configurations can have a multi-layer stacked transverse cross-sectional size that is between about 0.025 inches to about 0.1 inches, typically between about 0.056 inches to about 0.080 inches. Other pitches and numbers of revolutions can be used to form a triple or even greater layer of stacked coils. The winding operations can be continuously or substantially continuously repeated a plurality of times to form a plurality of CSMs 8 along a length of a lead. For a lead 20 having a length of about 72 cm, the CSMs 8 can have a length of about 4cm and the lead can have about 17 CSMs 8.

[0241] While not wishing to be bound to any one method of forming the conductor MCSMs, an exemplary set of operations is provided below that can be used to carry out a winding operation for a two conductor three-layer lead using the Accuwinder model 16 noted above.

1.1 Coil Winder Set-Up

- 1.1.1 Turn the coil winder ON and the computer ON.
- 1.1.2 Turn the air compressor ON, set air pressure to a minimum of 60 PSI
- 1.1.3 Set air pressure on the coil winder to about 20 PSI, cycle foot pedal/actuator several times and readjust as necessary.
- 1.1.4 Load two copper wire spools on the coil winder carriage.
- 1.1.5 Orient the spools such that the wire leaves from the posterior side of the spools and rotates the spools clockwise during winding.
- 1.1.6 Manually slide the carriage from left to right to ensure no obstacles, position carriage to far left position for remainder of set-up. (*Note: All references herein to orientation on coil winder are from facing the coil winder i.e., operator's perspective. The coil assembly produced via this process are referenced such that the left end of the coil becomes the distal end and the right end becomes the proximal end.*)
- 1.1.7 Loading a Coiling Mandrel
 - 1.1.7.1 Slide the inner liner over the coiling mandrel.
 - 1.1.7.2 Trim the excess length of the inner liner so that the ends are flush with the coiling mandrel.

- 1.1.7.3 Secure the coiling mandrel/inner liner at both ends of the coil winder, beginning with the left side. *(Note: the coiling mandrel/inner liner should hit the inside stops of both chucks. Chucks should be tightened carefully so that the coiling mandrel/inner liner is centered and tightly gripped.)*
- 1.1.7.4 After securing the left side chuck, depress and hold foot pedal to advance tensioning mechanism on right chuck. Secure coiling mandrel/inner liner in right chuck. Release foot pedal. To ensure proper tensioning, confirm that a portion of the air cylinder is visible.
- 1.1.8 Coil Winder Settings
 - 1.1.8.1 Confirm that toggle switch is set to "CW" (clockwise)
 - 1.1.8.2 Confirm coil wire guide is attached to the coil winder and is adjusted such that the center of the coil wire guide tube is centered or slightly below the level of the coiling mandrel/inner liner.
 - 1.1.8.3 Confirm that the coil wire guide tube is perpendicular to the coiling mandrel/inner liner.
 - 1.1.8.4 Confirm that the spacing between the coil wire guide tube and the coiling mandrel/inner liner is 0.090" using a pin gauge.
 - 1.1.8.5 Adjust upper and lower felt tensioning clamps such that the distance between the top of the screw head and the top of the felt tensioning clamp equals approximately 1".
 - 1.1.8.6 Set tensioning guide roller to 30.
- 1.1.9 Coil Winder Control Settings
 - 1.1.9.1 From the desktop of the coil winder controller, select the folder: "2 conductor leads", then select the application file "Winder9".
 - 1.1.9.2 Press "w" to choose "wind an existing coil" from the menu prompt.
 - 1.1.9.3 Enter file name. At the next prompt, select "n" to not display the data.
 - 1.1.9.4 Position safety fence to the furthest right position.
- 1.1.10 Confirm correct RPMs of the coil winder according to the following steps:
 - 1.1.10.1 Where prompted, press "w".
 - 1.1.10.2 Simultaneously press "enter" on keyboard and start the stop watch.
 - 1.1.10.3 Allow the coil winder to run for 60 seconds, then disengage the safety clutch to stop the coil winder.
 - 1.1.10.4 Confirm on the monitor that the "Revolutions Count" equals 60 ± 5 RPMs.
 - 1.1.10.5 If the "Revolutions Count" does not equal 60 ± 5 RPMs, then adjust the speed control dial and repeat the steps above until the desired speed is reached.
- 1.1.11 Reset coil winder by turning power off, then on. Close "winder9" window on coil winder controller.
- 1.1.12 Perform "phantom run" to warm up coil winder according to the following steps.
 - 1.1.12.1 Set coil winder controller settings as outlined above.
 - 1.1.12.2 Where prompted, press "w", then press "enter".
 - 1.1.12.3 Allow winder to run through full winding process.
 - 1.1.12.4 Disengage carriage and slide to left most position.

Feed the copper wire through the top left two guiding tubes (with the left spool wire through the left tube and the right spool wire through the right tube); through the upper felt tension clamp; through the guide/tension rollers; through the lower felt tension clamp; through the coil winder guide and under the mandrel

- 1.1.13 Gently pull on copper wires ensuring that there is a slight tension on wire.
- 1.1.14 With the copper wires going under the coil mandrel/inner liner tubing, attach them with to the wire holder on the left chuck. Secure.
- 1.1.15 Set coil winder controller settings as outlined above.
- 1.1.16 Where prompted, press “w” and press “enter” to start the coil winding process.
- 1.1.17 Observe the coil winding process for irregularities.
- 1.1.18 On completion of the copper MCSM coil, remove the copper MCSM from the coil winder and inspect the copper MCSM coil:
 - 1.1.18.1 Coiling mandrel should move with minimal friction;
 - 1.1.18.2 Coil should not move with respect to the inner liner/tubing;
 - 1.1.18.3 No gaps wider than two wire diameters through which the coil mandrel can be seen;
 - 1.1.18.4 No overlaps greater than two wire thicknesses;
 - 1.1.18.5 Distal section of the most distal CSM exhibits typical three layer construction.
- 1.1.19 Replace the copper wire spools with DFT cable spools of approximately the same diameter/amount of wire.
- 1.1.20 Feed the DFT cable through the top left two guiding tubes (with the left spool wire through the left tube and the right spool wire through the right tube); through the upper felt tension clamp; through the guide/tension rollers; through the lower felt tension clamp; and through the coil winder guide.
- 1.1.21 Gently pull on DFT cable ensuring that there is a slight tension on cable.

1.2 MCSM Assembly

- 1.2.1 If not already in position, move the carriage and safety fence to the furthest left position.
- 1.2.2 Load a coiling mandrel according to steps outlined above.
- 1.2.3 Set coil winder controller settings as outlined above.
- 1.2.4 Where prompted, press “w” and press “enter” to start the coil winding process.
- 1.2.5 Observe the coil winding process and note any irregularities on the back of the production router.
- 1.2.6 Apply adhesive (typically UV glue) to the single layer coil at the proximal end of the coil (e.g., using an acid brush); as appropriate, UV cure for 20 seconds; and confirm that the coil/cables are secure on the inner liner tubing. Repeat if necessary.
- 1.2.7 Trim the cable behind the coil winder guide, remove the coil assembly from the winder and slide a 0.070” ID PET HST x 1 cm over 5-7 mm of the single layer coil at the proximal end and the remainder over the adjacent CSM.
- 1.2.8 Set the hot air gun to 2.5 on air and 5 on heat and run for 2-3 minutes before use.
- 1.2.9 Holding the air gun nozzle 5-10 cm away from the PET HST, shrink the PET HST tubing to secure the cables and the coil to the inner tubing/liner. If the PET HST was damaged during the heat shrink process, remove the PET HST and apply a new section of PET HST following the same process.

- 1.2.10 Trim the distal ends of the inner tubing/liner, which were inside the chucks.
- 1.2.11 Mark the ends of the coiled section on the inner tubing.
- 1.2.12 Serialize the coil: Place the coil assembly in a transport tube and assign a number to the coil using the following code: month-day-year-lead number (e.g. 081307-1). Label the transport tube with the lead /coil number.
- 1.2.13

1.3 MCSM Coil Assembly Inspection:

- 1.3.1 Measure and record length of the MCSM. Length should equal 67.5 ±1.5 cm.
- 1.3.2 Inspect the movement of the coiling mandrel in the inner tubing/liner. The coil mandrel should move with minimal friction.
- 1.3.3 Coil should not move with respect to the inner liner/tubing.
- 1.3.4 Inspect coil uniformity with Micro Vu.
 - 1.3.4.1 No gaps wider than two wire diameters through which the coil mandrel or underlying sleeve can be seen;
 - 1.3.4.2 No overlaps greater than two wire thicknesses;
 - 1.3.4.3 Distal section of the most distal CSM exhibits typical three layer construction.

1.4 Electrode Assembly:

The electrodes can be attached to the MCSM in the following order:

- Proximal-Distal (IPG) electrode
- Proximal-Proximal (IPG) electrode
- Distal-Proximal/ground electrode
- Distal-Distal/sensing electrode

Note: Electrode labeling is as follows, the first term identifies the end of the MCSM, the second term refers to the relationship between the two electrodes on each end.

Note: The Electrode Assembly process can be conducted under a microscope.

- 1.4.1 Proximal Electrodes Connection:
 - 1.4.1.1 At the proximal (PET heat shrink) end of the MCSM assembly, uncoil both conductors from the inner tube/liner to the point where the PET heat shrink begins.
 - 1.4.1.2 Remove the excess adhesive with the aid of a microscope, as needed, being careful not to damage the inner tube/liner.
 - 1.4.1.3 Remove the ETFE insulation from the full length of a single conductor. Pull conductor straight, apply flux and tin the conductor with solder. Wipe excess flux using IPA and Kimwipe.
 - 1.4.1.4 Slide the distal end of the electrode to the beginning of the PET heat shrink with both cables inside the electrode. Solder the electrode to the tinned cable using minimal solder and flux by heating the cable itself at the proximal junction of the cable and the electrode.
 - 1.4.1.5 Gently pull the electrode to ensure a good solder joint. Trim excess uninsulated cable length, which may be extending outside the electrode.
 - 1.4.1.6 Remove the ETFE insulation from the second cable, beginning 6mm away from the proximal end of the previously soldered electrode. Pull cable straight, apply flux and tin the conductor with solder. Wipe excess flux using IPA and Kimwipe.

- 1.4.1.7 Slide a 5 mm long piece of 0.042" PET HST over the inner tubing/ liner and the cable so that the distal end of the heat shrink is flush with the proximal end of the previously soldered electrode.
- 1.4.1.8 Heat shrink the tubing as above.
- 1.4.1.9 Slide the electrode and space it such that there is a 6 mm gap between the electrodes. Solder the electrode to the tinned cable using minimal solder and flux by heating the cable itself at the proximal junction of the cable and the electrode.
- 1.4.1.10 Gently pull the electrode to ensure good solder joint. Trim excess uninsulated cable length, which may be extending outside the electrode.
- 1.4.2 Distal Electrode Connection
 - 1.4.2.1 Using the multimeter identify the cable corresponding to the proximal-distal electrode.
 - 1.4.2.2 Using a blade, remove the ETFE insulation beginning 5 mm from the distal end of the first CSM. Pull cable straight, apply flux and tin the conductor with solder. Wipe excess flux using IPA and Kimwipe.
 - 1.4.2.3 Slide the distal-proximal electrode with the cables inside the electrode to the point where the insulation on the tinned cable ends. Solder the electrode to the tinned cable using minimal solder and flux by heating the cable itself at the distal junction of the cable and the electrode.
 - 1.4.2.4 Gently pull the electrode to ensure good solder joint. Trim excess uninsulated cable length, which may be extending outside the electrode.
 - 1.4.2.5 Using a blade, remove the ETFE insulation from the second cable, beginning 9 mm away from the distal end of the previously soldered electrode. Pull cable straight, apply flux and tin the conductor with solder. Wipe excess flux using IPA and Kimwipe.
 - 1.4.2.6 Slide an 8 mm long piece of 0.042" PET HST over the inner tubing/liner and the cable so that the proximal end of the heat shrink is flush with the distal end of the previously soldered electrode.
 - 1.4.2.7 Heat shrink the tubing as above.
 - 1.4.2.8 Slide the electrode and space it such that there is a 9 mm gap between the electrodes. Solder the electrode to the tinned cable using minimal solder and flux by heating the cable itself at the distal junction of the cable and the electrode.

[0242] Those of skill in the art will appreciate that other operations and/or different parameters may be used and the scope of the invention is not to be limited to this example. Also, this example is for a two-conductor lead formed into a tri-layer MCSM configuration so additional coils of conductor may be used where more than two conductors are being formed into the lead.

[0243] In the drawings and specification, there have been disclosed embodiments of the invention and, although specific terms are employed, they are

used in a generic and descriptive sense only and not for purposes of limitation, the scope of the invention being set forth in the following claims. Thus, the foregoing is illustrative of the present invention and is not to be construed as limiting thereof. Although a few exemplary embodiments of this invention have been described, those skilled in the art will readily appreciate that many modifications are possible in the exemplary embodiments without materially departing from the novel teachings and advantages of this invention. Accordingly, all such modifications are intended to be included within the scope of this invention as defined in the claims. In the claims, means-plus-function clauses, where used, are intended to cover the structures described herein as performing the recited function and not only structural equivalents but also equivalent structures. Therefore, it is to be understood that the foregoing is illustrative of the present invention and is not to be construed as limited to the specific embodiments disclosed, and that modifications to the disclosed embodiments, as well as other embodiments, are intended to be included within the scope of the appended claims. The invention is defined by the following claims, with equivalents of the claims to be included therein.

CLAIMS

1. An RF/MRI compatible medical device comprising:
 - an elongate medical lead comprising at least one conductor with opposing proximal and distal portions, the at least one conductor comprising a plurality of preformed current suppression modules, each current suppression module comprising
 - a first forward section that extends in an axially forward direction for a first physical length then turns back to define a second reverse section that extends in a substantially opposing axial direction for a second physical length, then turns again to define a third forward section that extends in the axially forward direction for a third physical length, wherein the second reverse section comprises a coiled segment having a plurality of wound coils, wherein each current suppression module is configured and arranged to substantially suppress current induced by RF utilized during an MRI procedure.
2. A medical device according to Claim 1, wherein the first, second and third physical lengths are proximately located with respect to each other and occupy a sub-portion of an overall length of the at least one conductor.
3. A medical device according to any one of Claims 1 and 2, wherein the at least one conductor is a plurality of conductors, and wherein each of the plurality of conductors comprises a continuous single length of conductor with each having at least one set of the first forward, second reverse, and third forward sections, and wherein the lead is flexible.
4. A medical device according to any one of Claims 1-3, wherein each respective conductor has a plurality of sets of the first forward, second reverse, and third forward sections residing along the length of a respective conductor between the opposing distal and proximal portions.
5. A medical device according to any one of Claims 1-4, wherein at least one of the first and third forward sections has a coiled portion.
6. A medical device according to Claim 5, wherein at least one of the first forward, second reverse, and third forward sections extends under, over or through a neighboring section.

7. A medical device according to Claim 6, wherein at least one of the first forward, second reverse, and third forward sections resides proximate to and outside of a coiled portion of another section.
8. A medical device according to Claim 1, wherein the third forward section resides proximate the first forward section with the second reverse section therebetween.
9. A medical device according to any one of Claims 1-8, wherein the second reverse section has an electrical length that is about $\lambda/4$ or less in an MRI scanner and a physical length that is substantially the same or between about 30-70% that of the physical length of at least one of the first and third forward sections.
10. A medical device according to any one of Claims 1-9, further comprising an implantable or external medical device connected to an end portion of the lead, and wherein the at least one elongate conductor is a plurality of conductors.
11. A medical device according to Claim 3, the lead further comprising a plurality of electrodes, at least one electrode connected to one or more of the plurality of conductors.
12. A medical device according to Claim 3, wherein the plurality of conductors include at least one respective coiled first forward, second reverse, or third forward sections that are co-wound together with at least one of the other conductor's first forward, second reverse, or third forward sections at a substantially common physical lengthwise location.
13. A medical device according to any one of Claims 1-12, wherein the lead is implantable and connected at one end portion to an implantable therapeutic device and/or a lead extension that connects to an implantable therapeutic device.
14. A medical device according to any one of Claims 1-13, wherein the at least one conductor is connected at the other end portion of the lead to at least one implantable electrode.
15. A medical device according to any one of Claims 1-14, wherein the lead is at least one of a cardiac pacemaker lead, a cardiac defibrillator lead, a cardiac monitor lead, an implantable brain Neuromodulation, or spinal cord stimulation lead.

16. A medical device according to any one of Claims 1-15, wherein the lead impedance has local maxima in a target frequency range associated with an operating frequency of an MRI Scanner, wherein optionally the lead has an impedance with at least two local impedance maxima corresponding to two RF MRI frequencies associated with MRI Scanners, including RF MRI frequencies corresponding to at least two of the following: 0.1 Tesla (T), 0.3 T, 0.7 T, 1.0 T, 1.5 T, 2.0 T, 2.5 T, 3 T, 4 T, 4.7 T, 7 T, and 9.4 T.

17. A medical device according to any one of Claims 1-16, wherein i) the distal end portion of the at least one conductor is connected to an electrocardiographic electrode and the proximal end portion is in communication with an electrocardiographic monitoring device; ii) the distal end portion of the at least one conductor is connected to an electroencephalographic electrode and the proximal end portion is in communication with an electroencephalographic monitoring device; iii) the distal end portion of the at least one conductor is connected to a blood pressure monitoring transducer and the proximal end portion is connected to a blood pressure monitoring device; or iv) at least one end portion of the at least one conductor is connected to a blood oxygen monitoring transducer and at least another end is in communication with a blood oxygen monitoring device.

18. A medical device according to any one of Claims 1-17, wherein the lead comprises a plurality of conductors, with the at least one conductor having the first forward, second reverse, and third forward sections being configured with multiple sets of turns defining multiple first forward, second reverse, and third forward sections, and wherein the conductor with the multiple sets of turns resides over an inner conductor.

19. A medical device according to any one of Claims 1-18, wherein the lead comprises a plurality of conductors, with the at least one conductor having the first forward, second reverse, and third forward sections being configured with multiple sets of turns defining multiple first forward, second reverse, and third forward sections, and wherein the conductor with the multiple sets of turns is an inner conductor in communication with a screw electrode for active fixation.

20. A medical device according to any one of Claims 1-19, wherein the conductors are insulated, the lead system further comprising an electrical insulator and/or RF shield of biocompatible material disposed over an external surface of the lead system.

21. A medical device according to Claim 1, wherein at least one of the at least one conductor is configured with at least one coiled conductor portion and at least one closely spaced serpentine shaped conductor portion and wherein, optionally, at least some of the serpentine shaped portion resides inside the coiled conductor portion of the respective conductor.

22. A medical device according to Claim 21, wherein at least one of the at least one conductor is configured so that at least some of the serpentine shaped portion resides above, below or to the side of the coiled portion.

23. A medical device according to Claim 21, wherein at least one of the at least one conductor has substantially straight conductor portions configured so that two conductor portions cross-over each other and extend in substantially opposing longitudinal directions.

24. A medical device according to Claim 1, wherein the at least one conductor comprises at least first and second conductors extending between opposing proximal and distal end portions of the lead, one or more of the conductors connected to at least one of a plurality of electrodes at the distal end portion thereof, wherein the first and second conductors comprise a substantially straight portion and a coiled portion, wherein the straight portion of the first conductor extends in a lengthwise direction outside and proximate to the second conductor coiled portion or inside and through the second conductor coiled portion.

25. A method of fabricating a medical lead, comprising:
providing a length of at least one elongate conductor; and
forming a plurality of preformed current suppression modules in each conductor by turning the at least one conductor back on itself at least twice to define two forward portions that extend lengthwise in an axially forward direction and at least one rearward portion, between the two forward portions, that travels in a substantially opposing rearward direction, wherein the rearward portion comprises a coiled segment having a plurality of wound coils, wherein each current suppression module is configured and arranged to substantially suppress current induced by RF utilized during an MRI procedure.

26. A method according to Claim 25, wherein the turning step comprises forming a conductor segment to have at least one longitudinally extending serpentine shape that merges into a substantially straight conductor segment.

2008229465 15 Apr 2013

27. A method according to Claim 25, wherein the turning step comprises coiling the at least one conductor.

28. A method according to any one of Claims 25-27, further comprising attaching an electrode to a distal end portion of the conductor.

Boston Scientific Neuromodulation Corporation

Surgi-Vision, Inc.

Patent Attorneys for the Applicant/Nominated Person

SPRUSON & FERGUSON

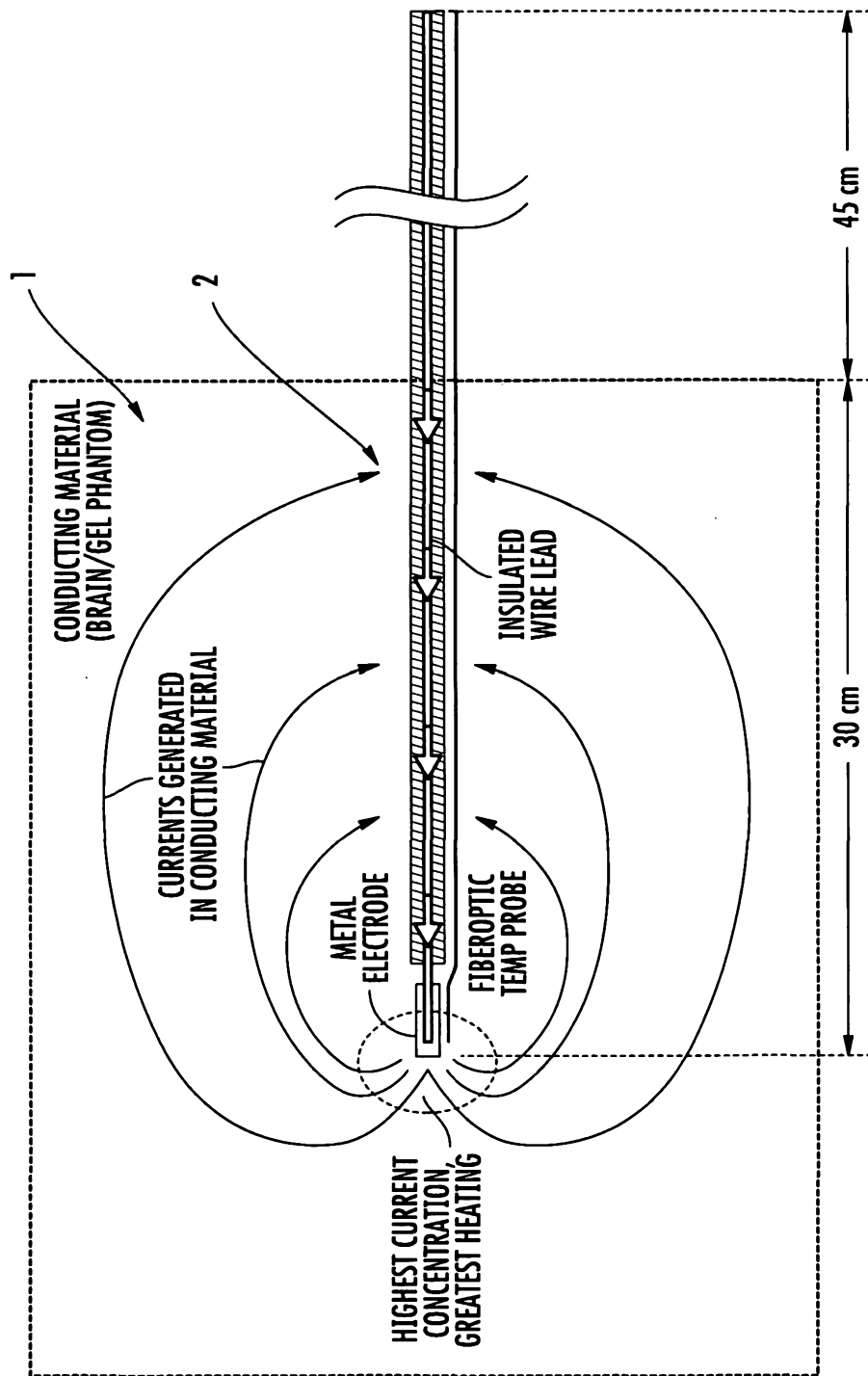

FIG. 1

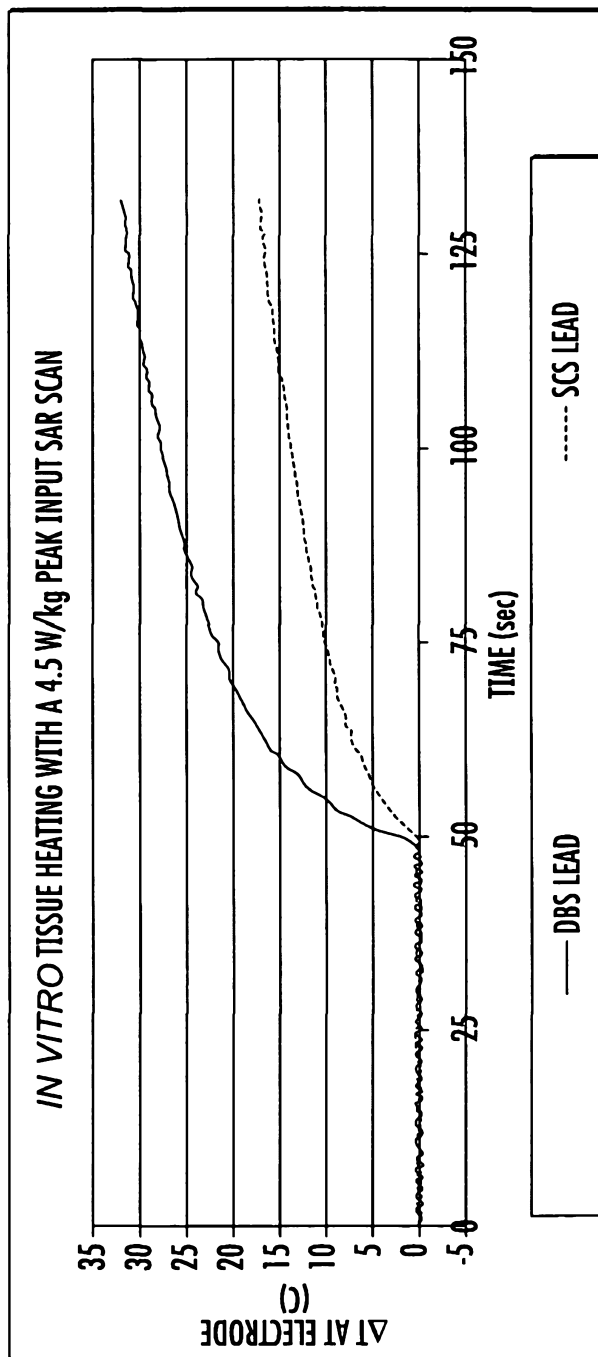

FIG. 2

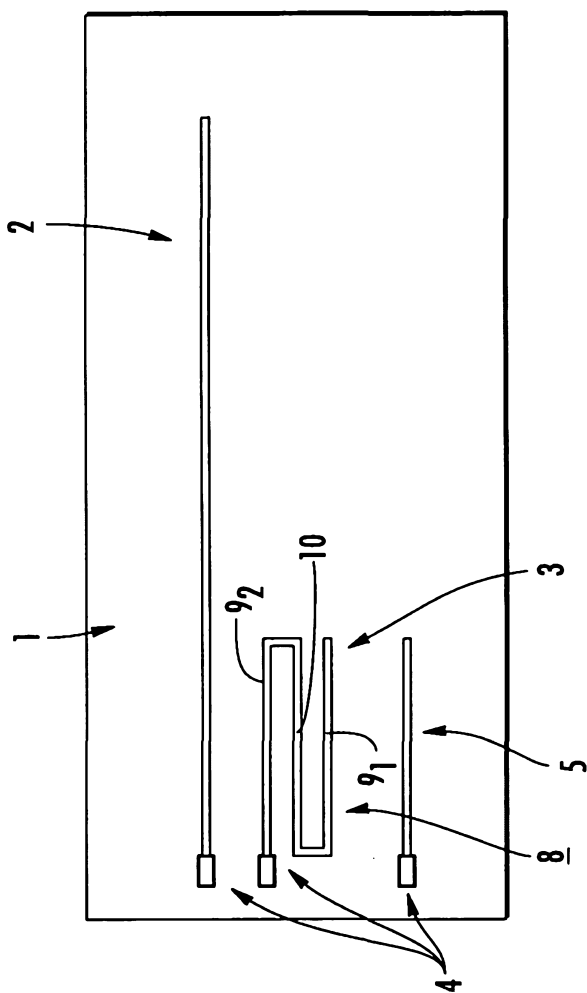

FIG. 3

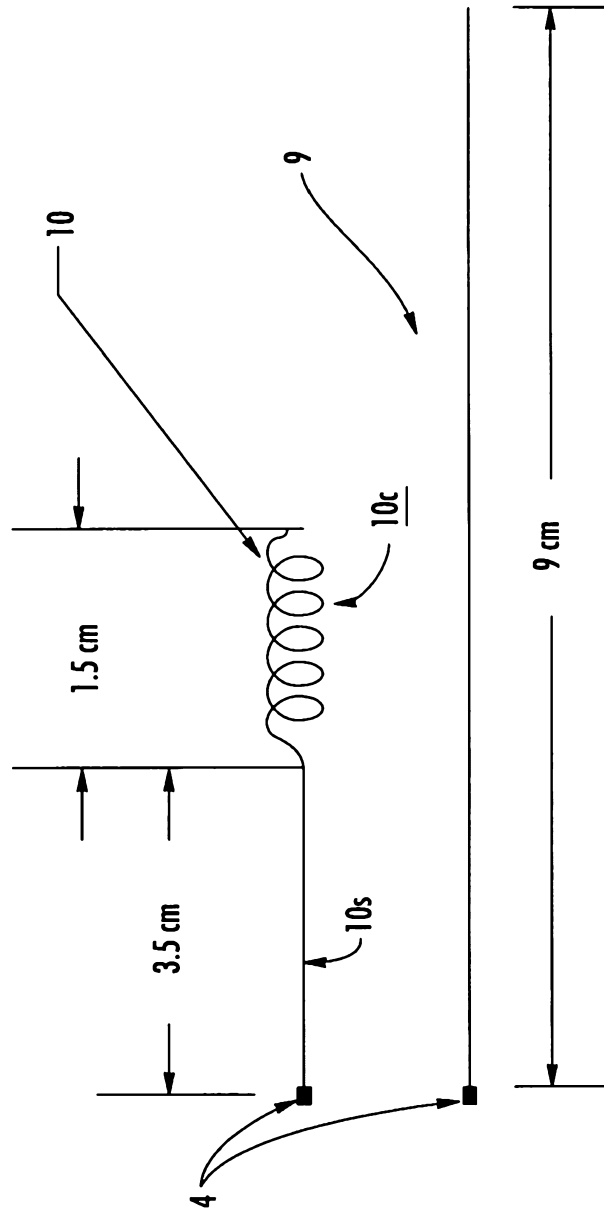

FIG. 4

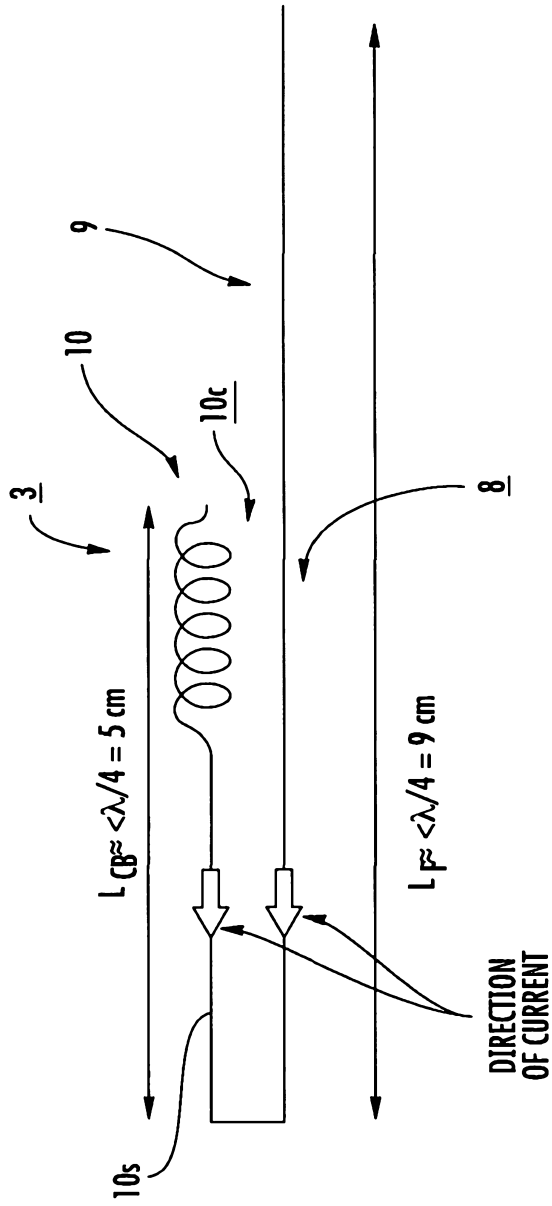

FIG. 5

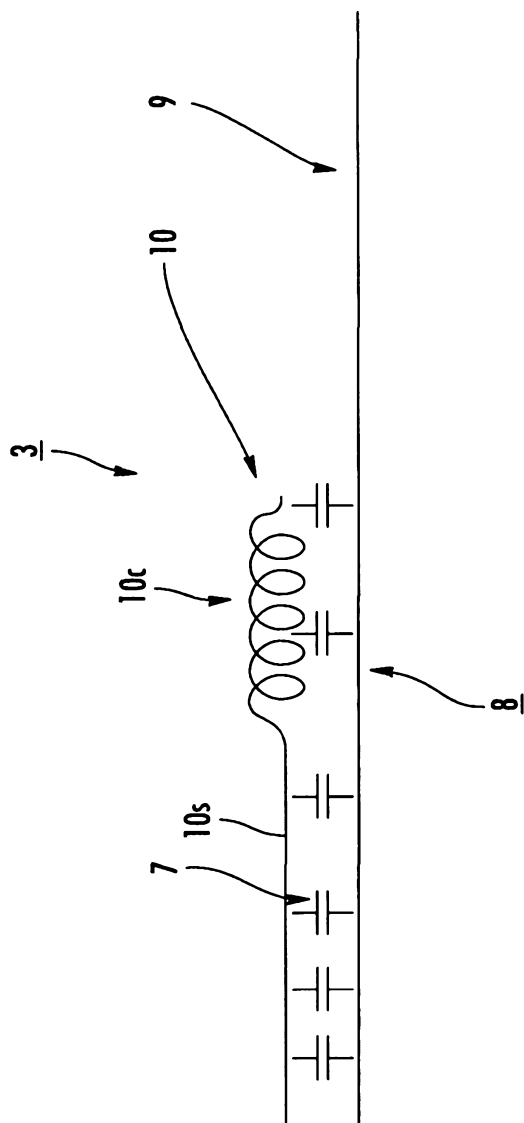

FIG. 6A

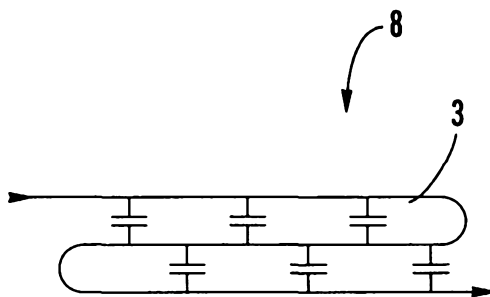

FIG. 6B

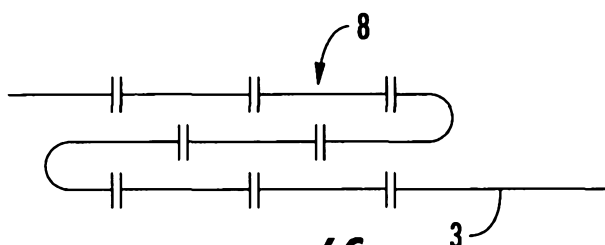

FIG. 6C

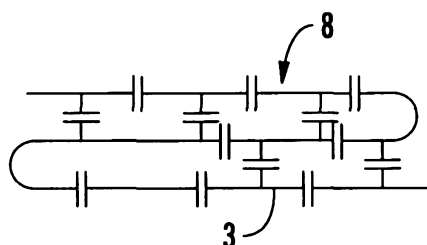

FIG. 6D

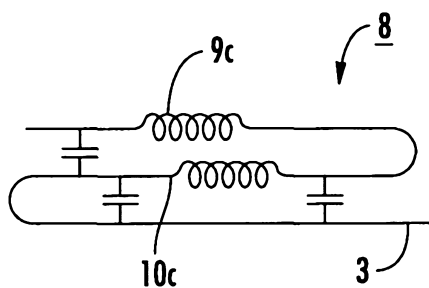

FIG. 6E

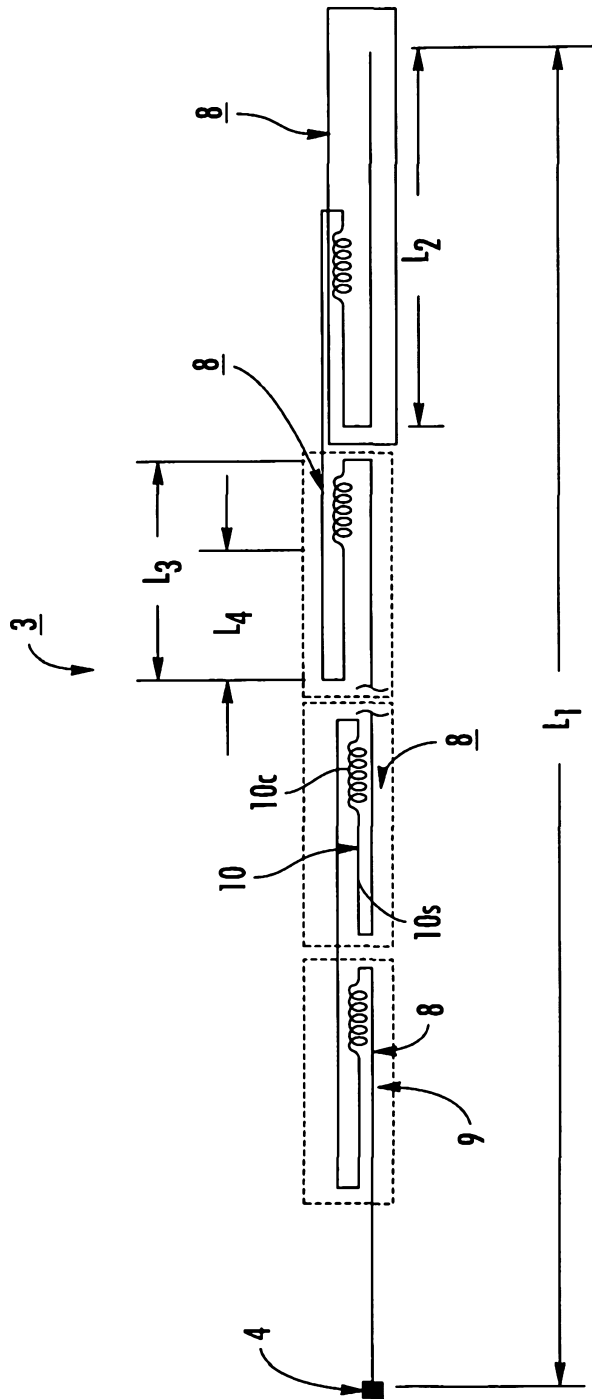

FIG. 7

9/67

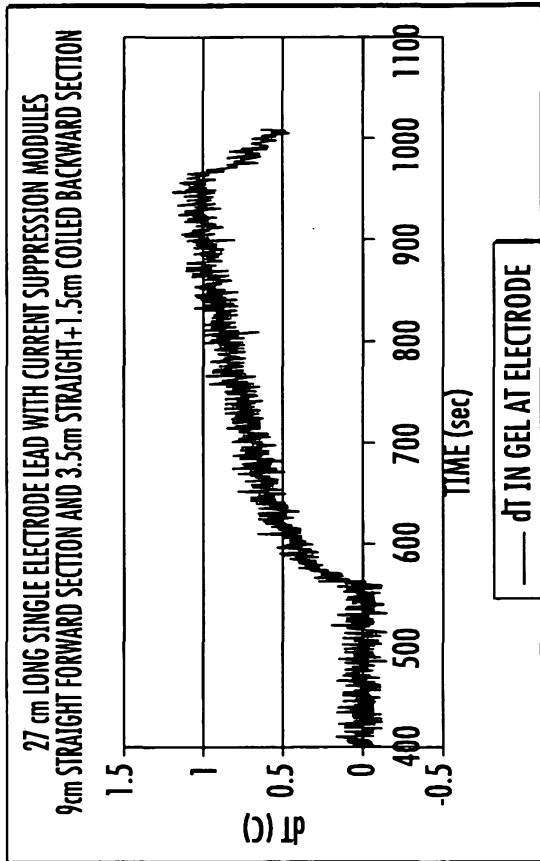

FIG. 8B

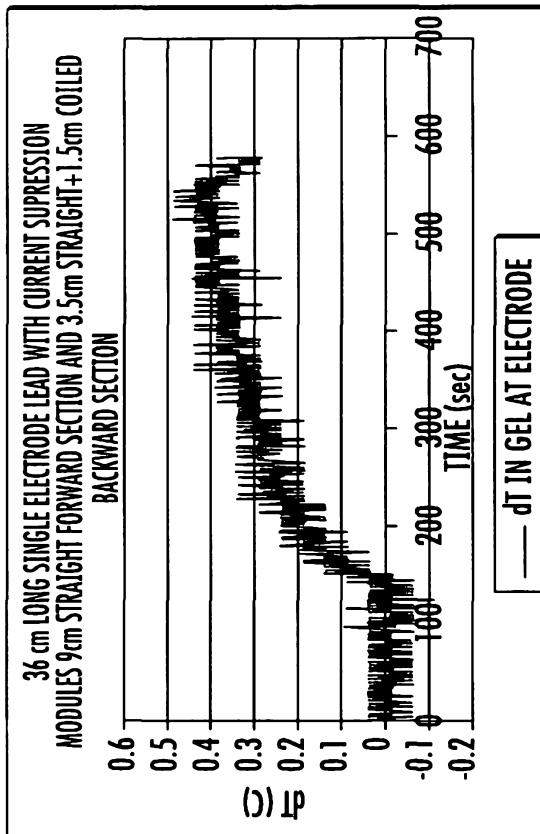

FIG. 8A

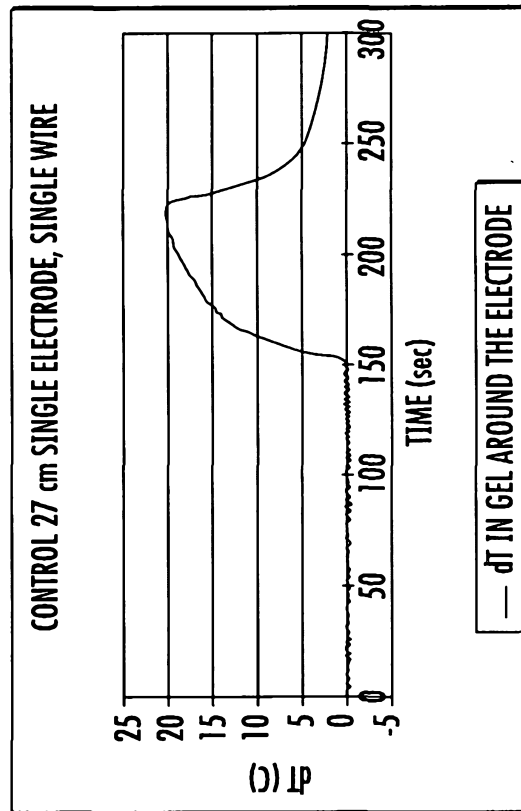

FIG. 8C

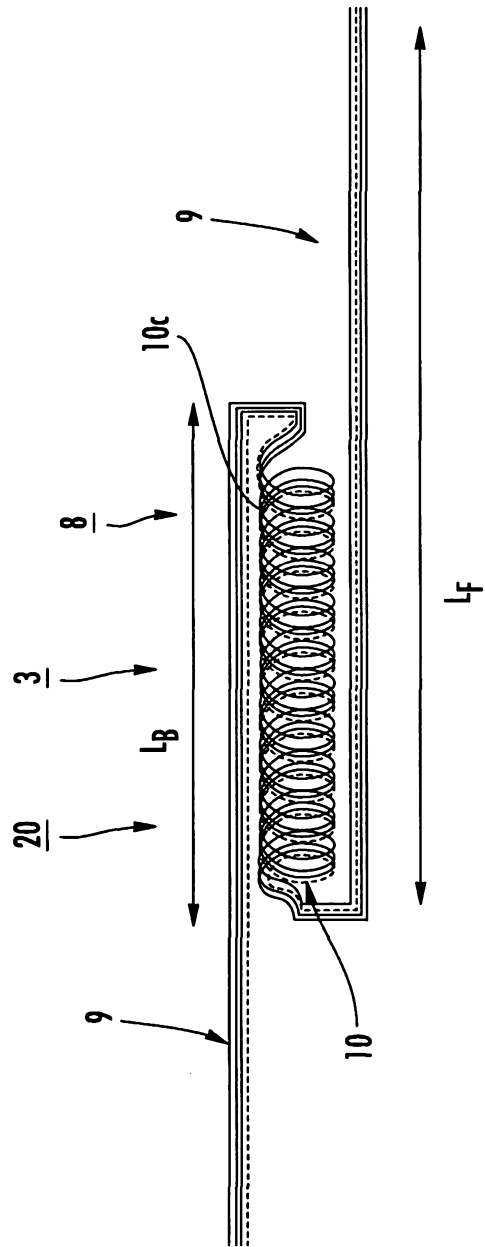

FIG. 9

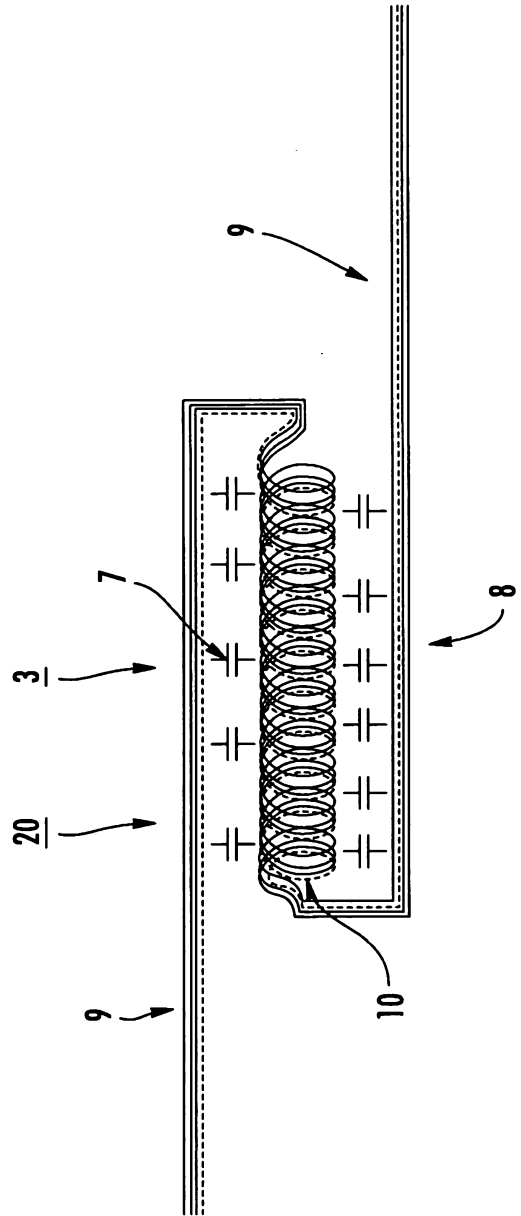

FIG. 10

12/67

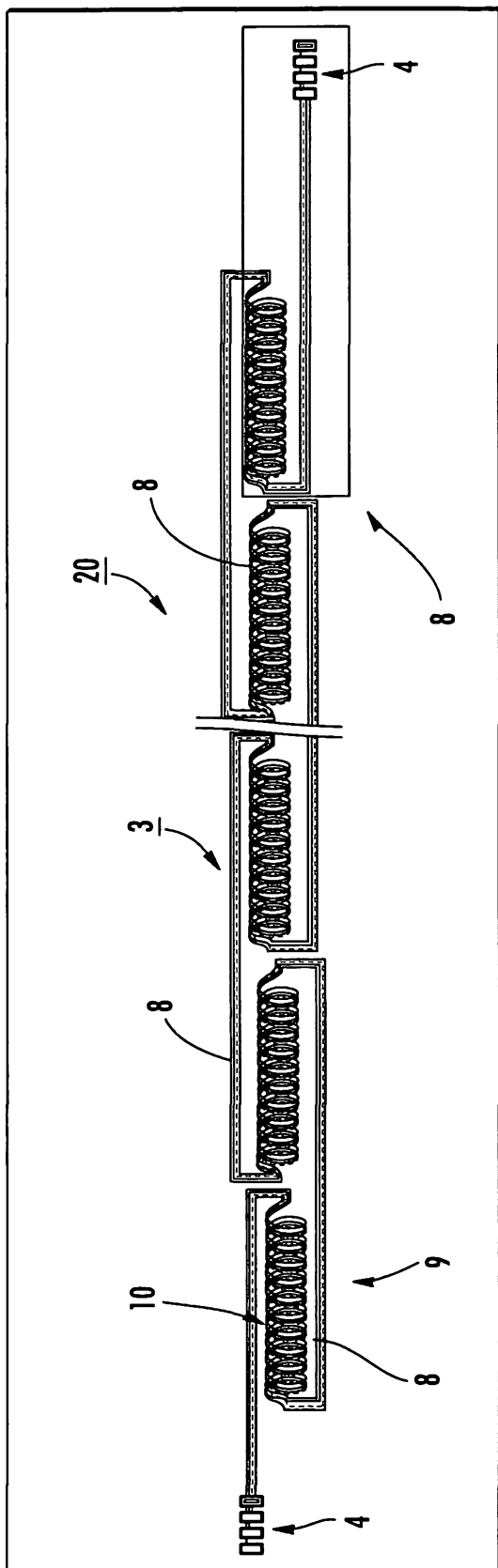

FIG. 11

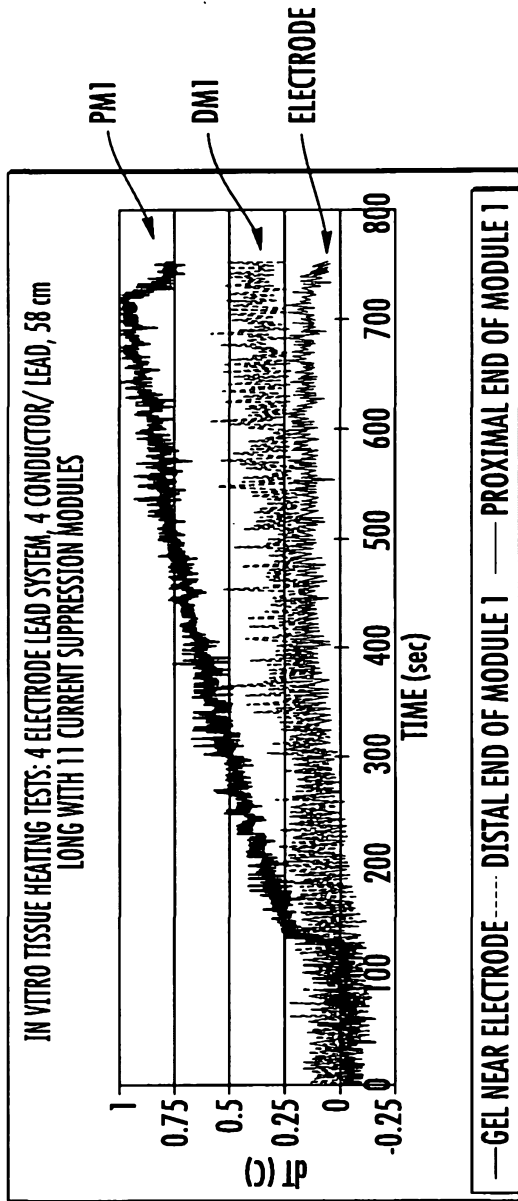

FIG. 13A

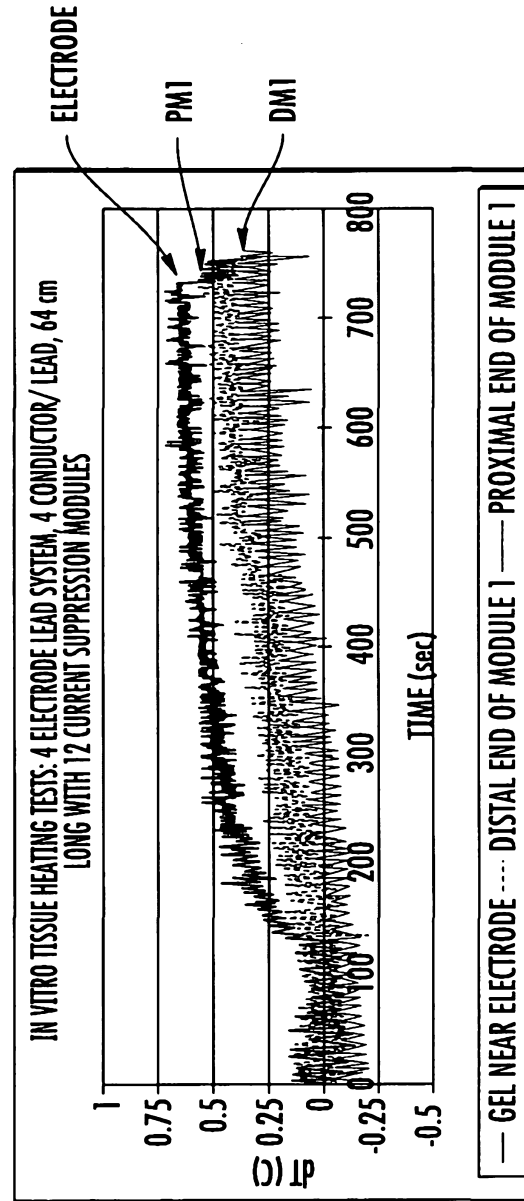

FIG. 13B

15/67

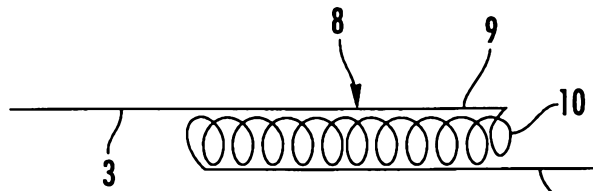

FIG. 14A

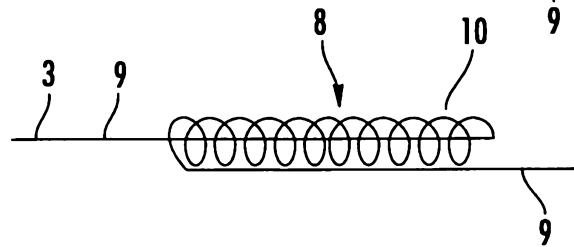

FIG. 14B

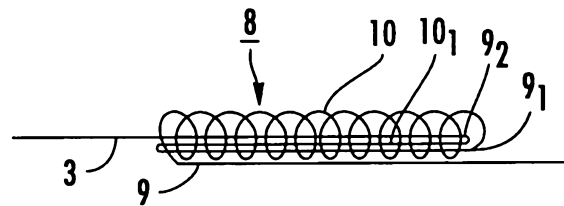

FIG. 14C

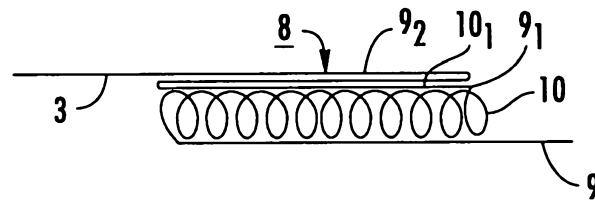

FIG. 14D

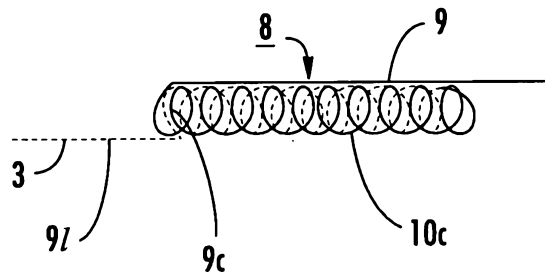

FIG. 14E

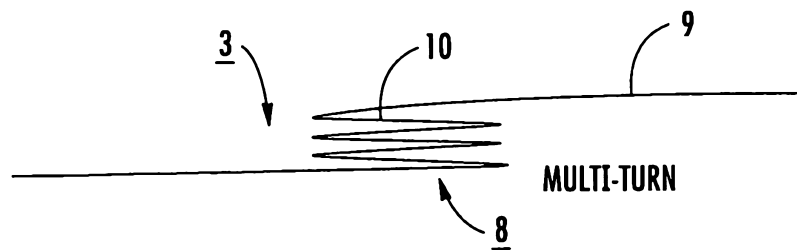

FIG. 14F

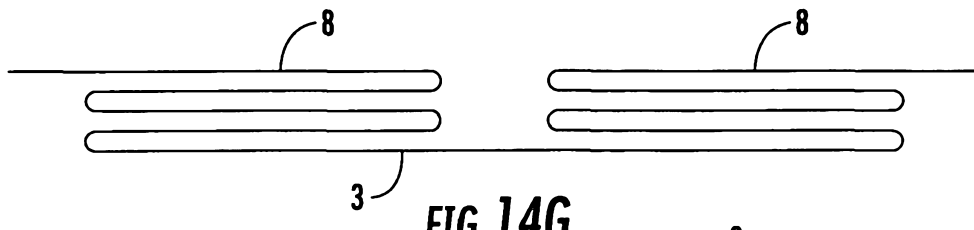

FIG. 14G

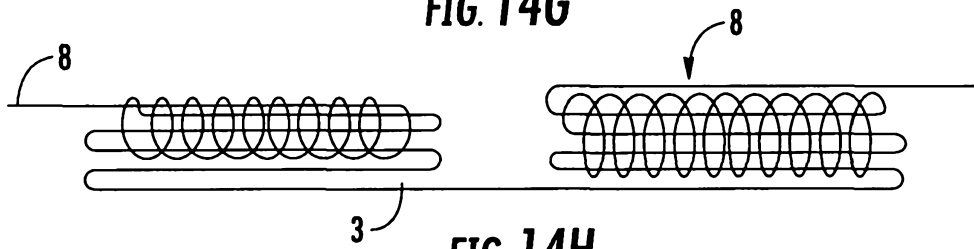

FIG. 14H

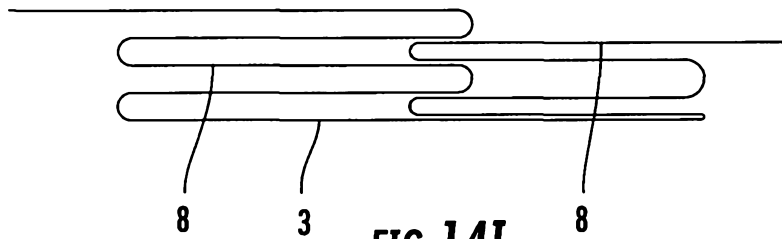

FIG. 14I

17/67

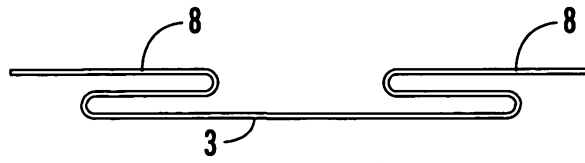

FIG. 14J

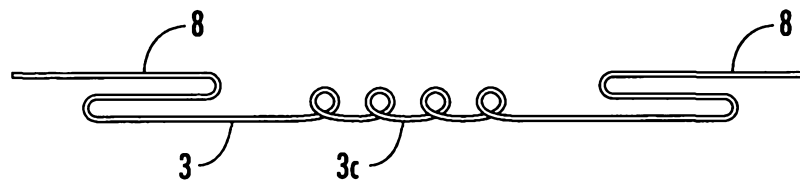

FIG. 14K

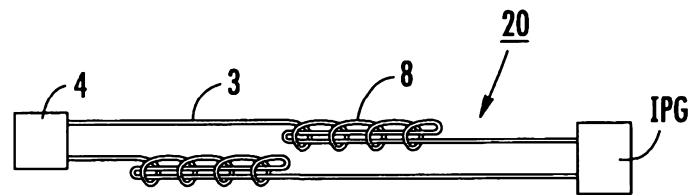

FIG. 14L

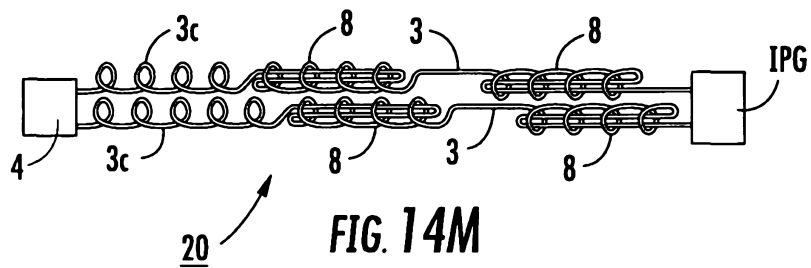
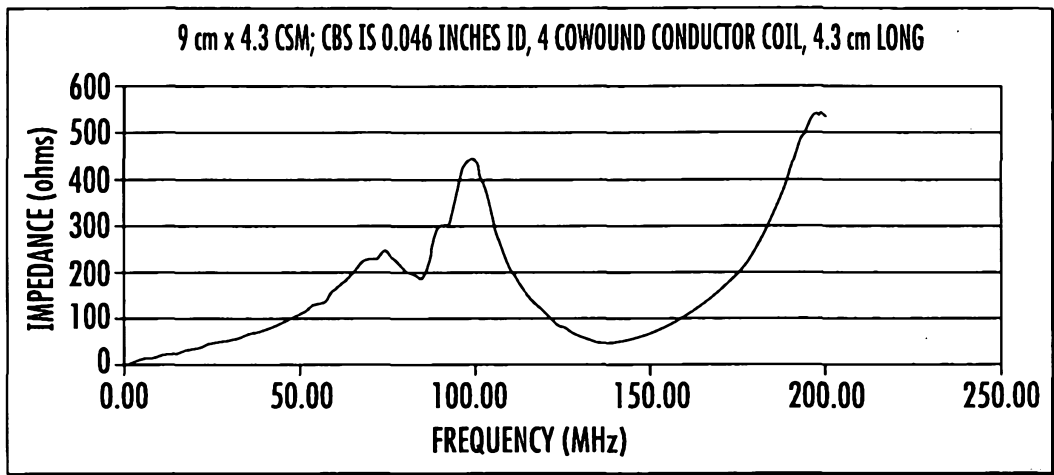

FIG. 14M

18/67



THIS IMPEDANCE IS MEASURED BY CONNECTING THE MEASURE PROBE AS SHOWN IN FIGURE BELOW.

FIG. 15A

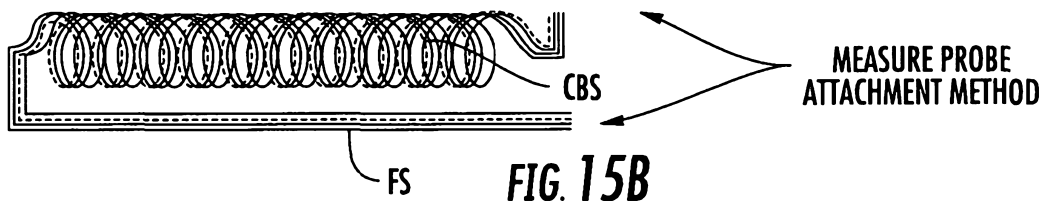

FIG. 15B

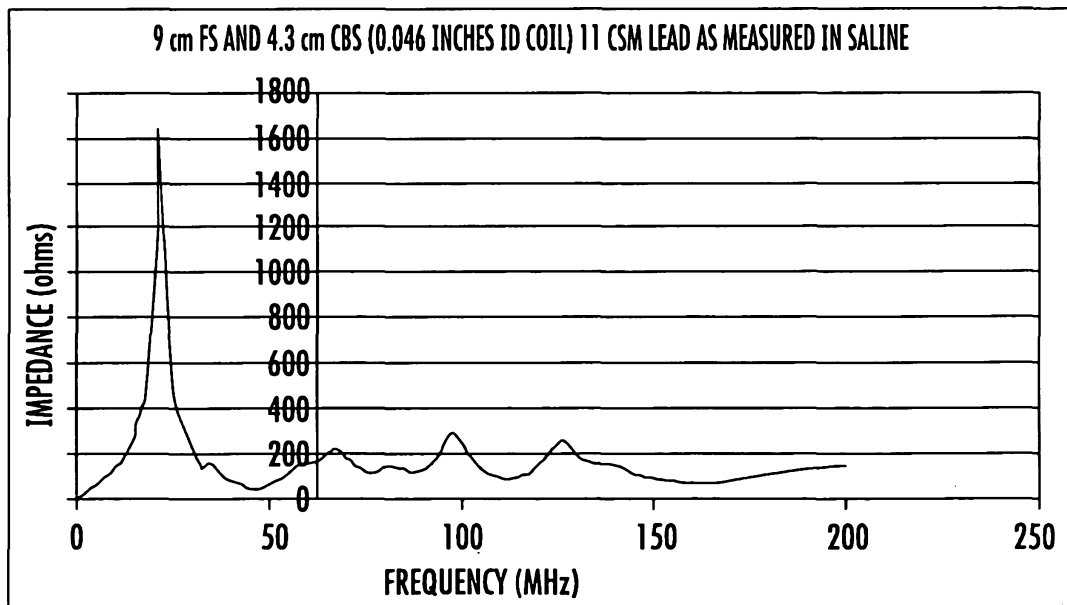
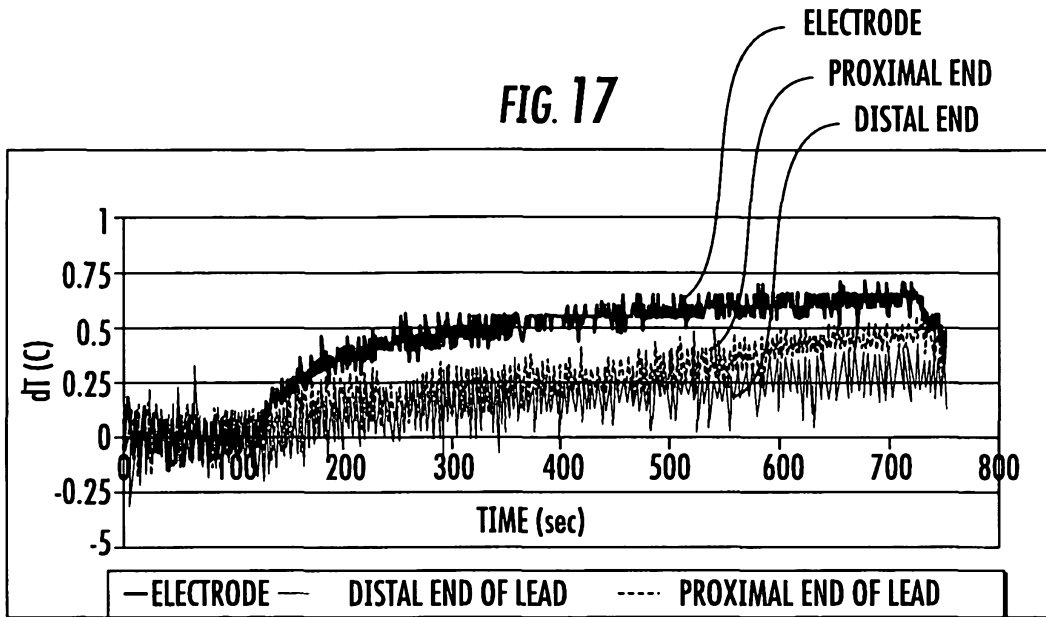

FIG. 16

19/67



FSPGR SEQUENCE, TE=4.2, TR=17.3, BW=125, FA=170, 256=128 IMAGE MATRIX;
TG=155- PEAK SAR~4.2 W/Kg

FIGURE 17: LOCAL TEMPERATURE CHANGE MEASURED AT DIFFERENT LOCATIONS ALONG THE LENGTH OF A 11 CSM LEAD/PROBE IN A 1.5T MRI SCANNER.

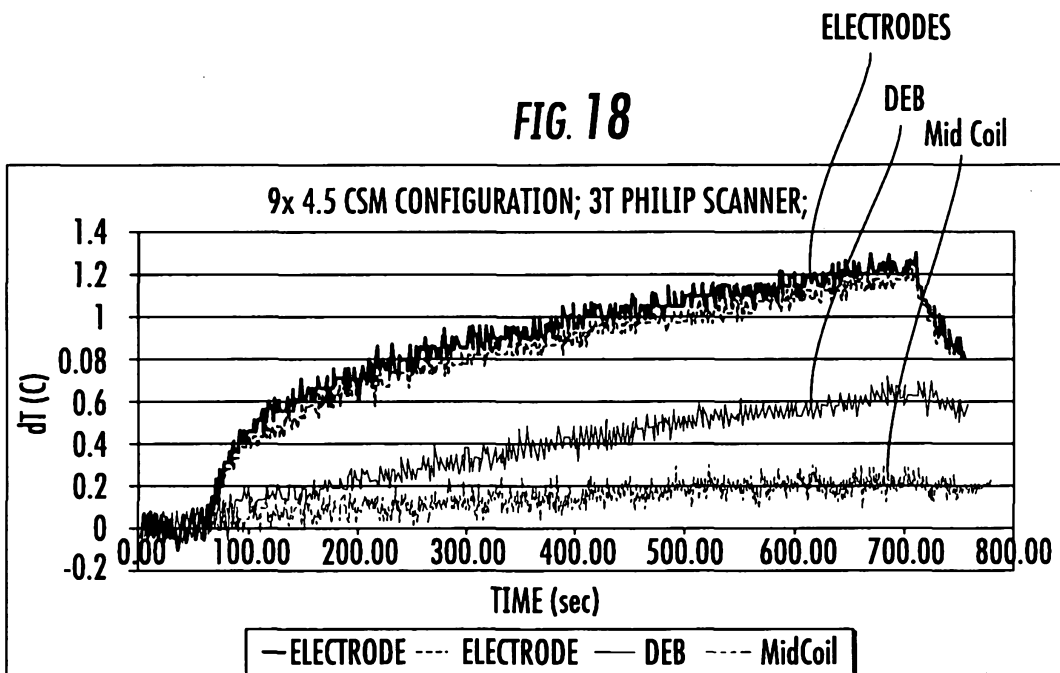

MEASURED PEAK INPUT SAR=4.2 W/Kg

FIGURE 18: LOCAL TEMPERATURE CHANGE MEASURED AT DIFFERENT LOCATIONS ALONG THE LENGTH OF A 11 CSM LEAD IN A 3T MRI SCANNER.

20/67

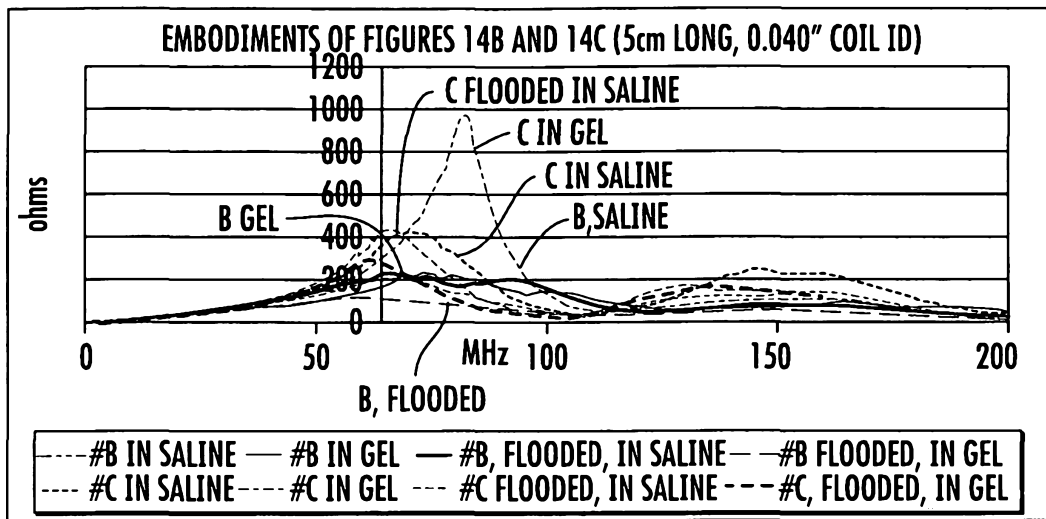

FIG. 19

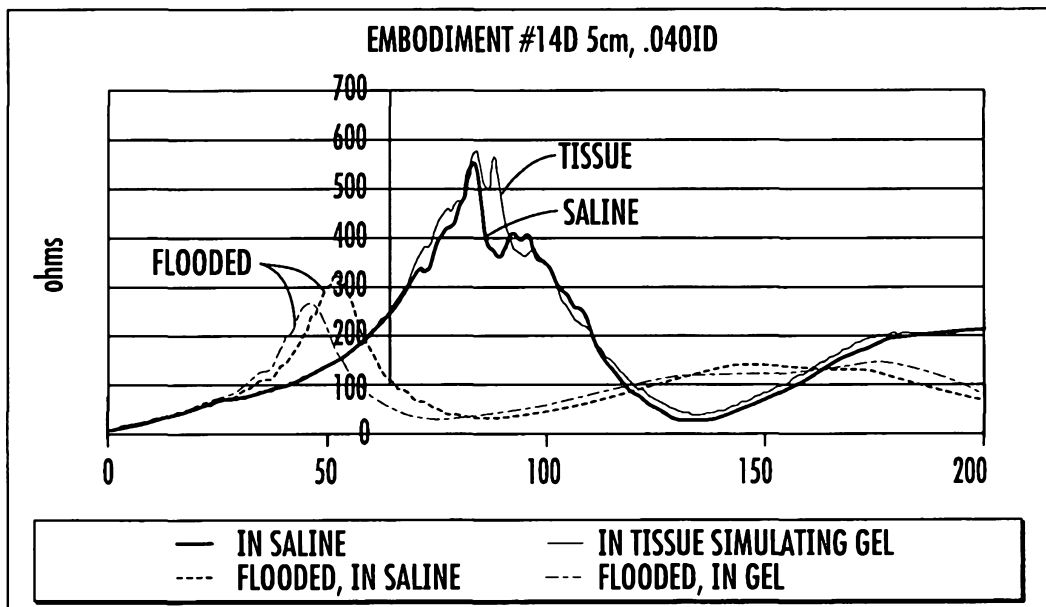

FIG. 20

21/67

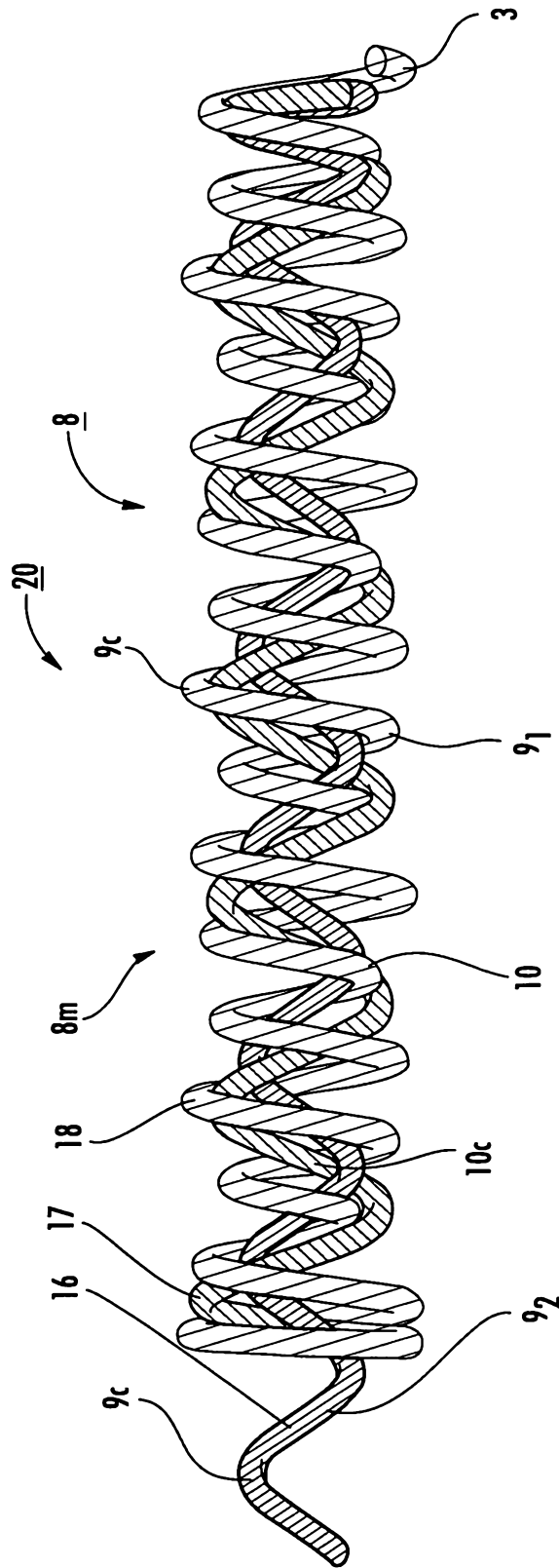

FIG. 21A

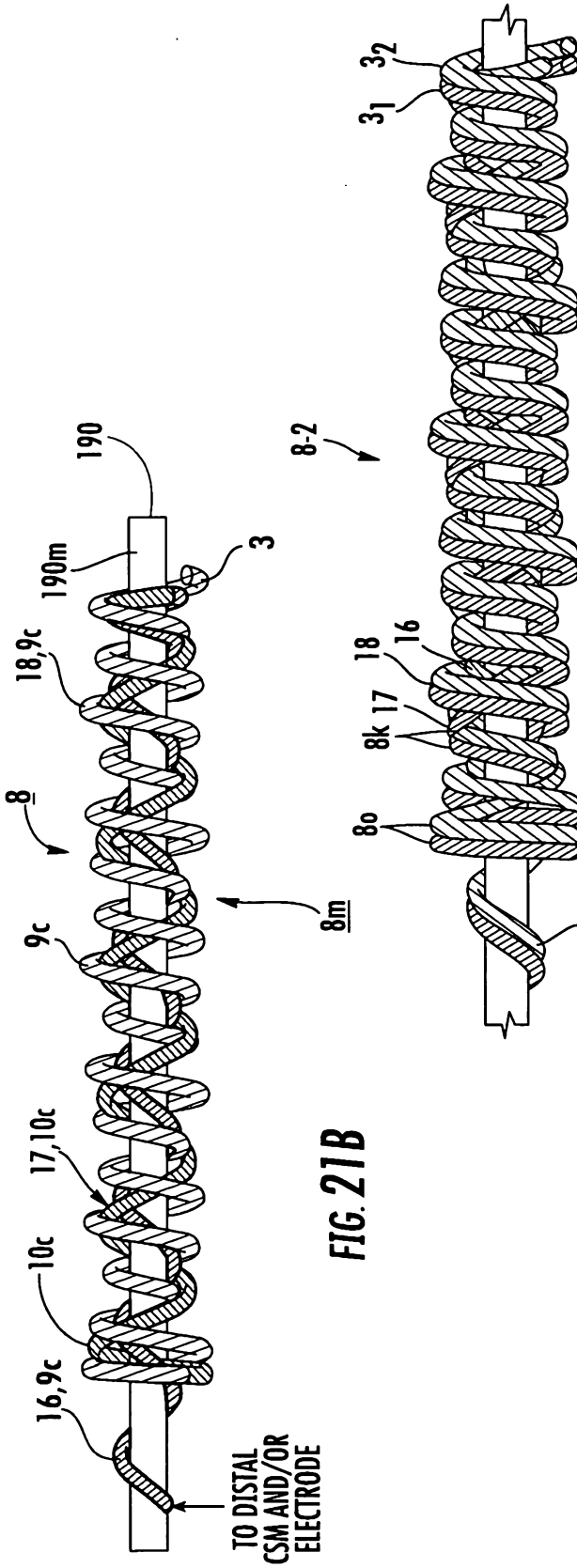

FIG. 21B

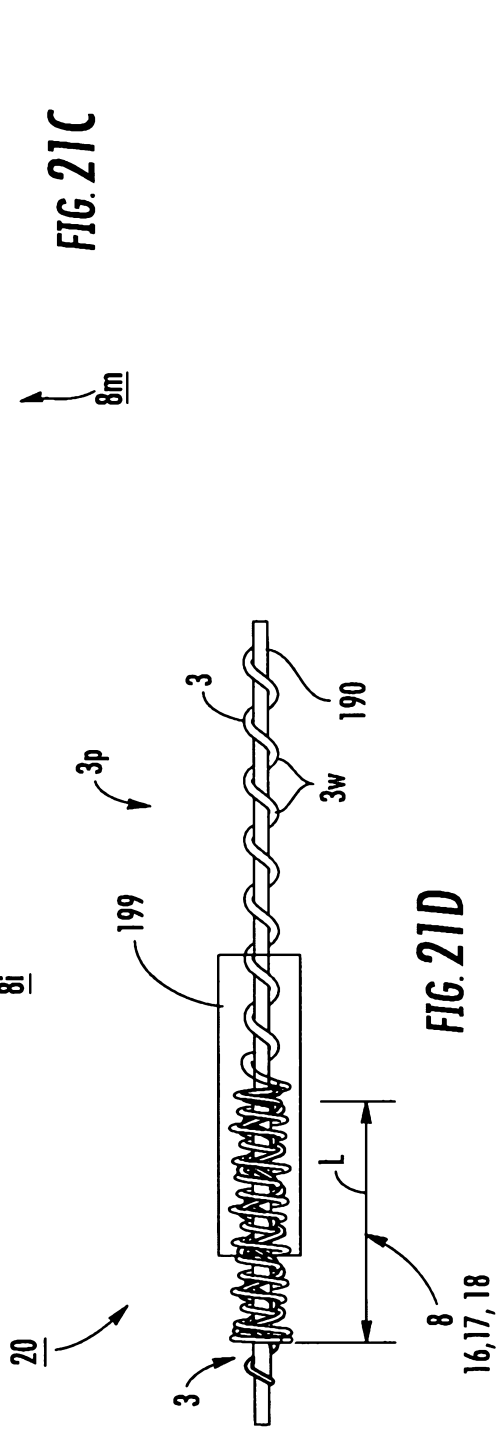

FIG. 21C

FIG. 21D

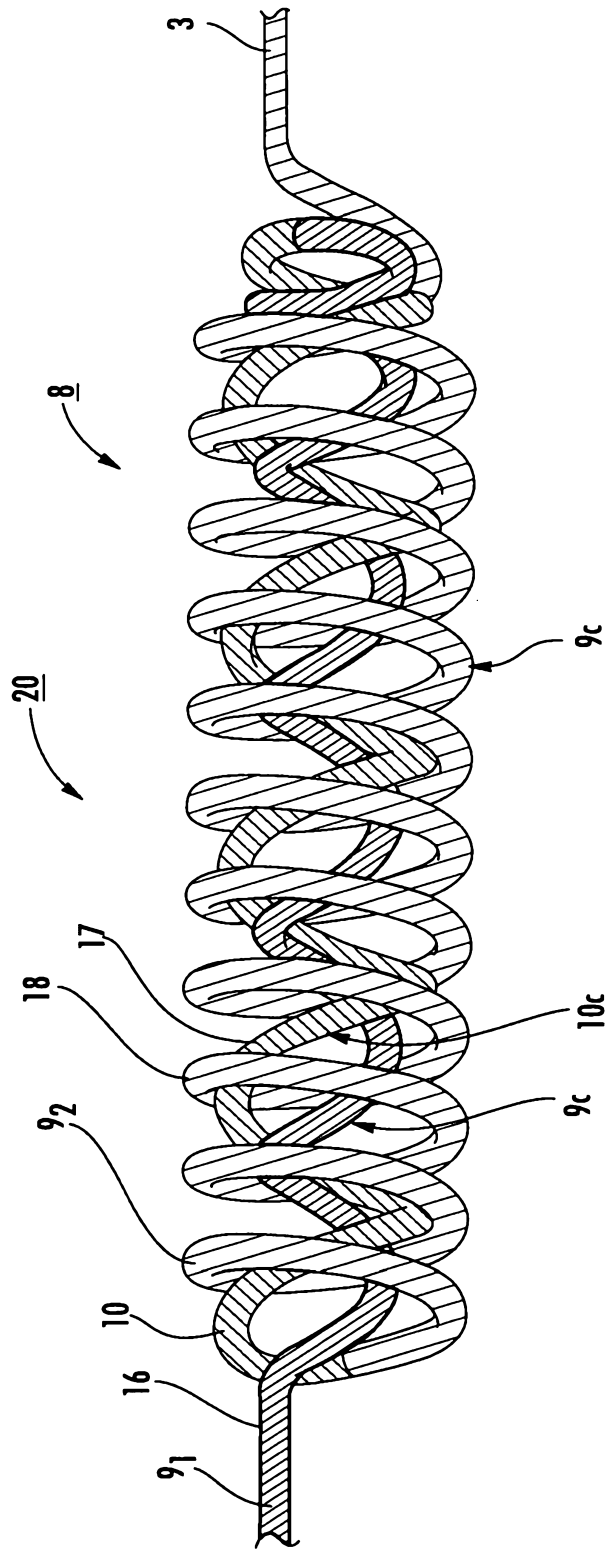

FIG. 22A

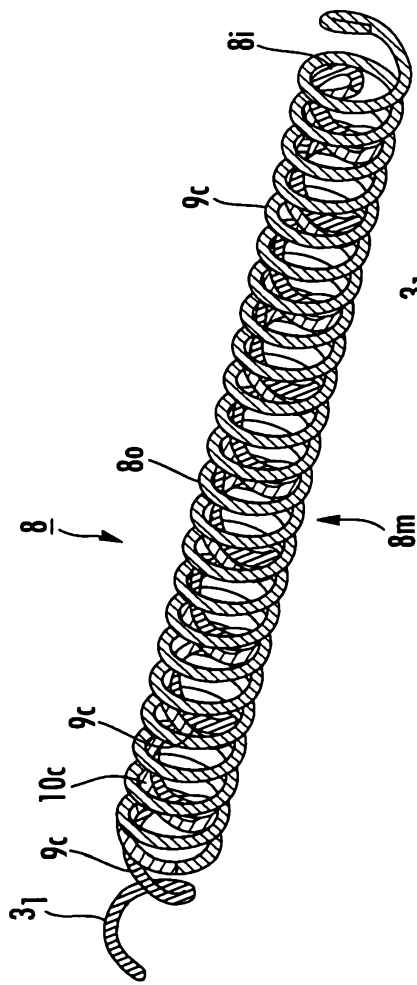

FIG. 22B

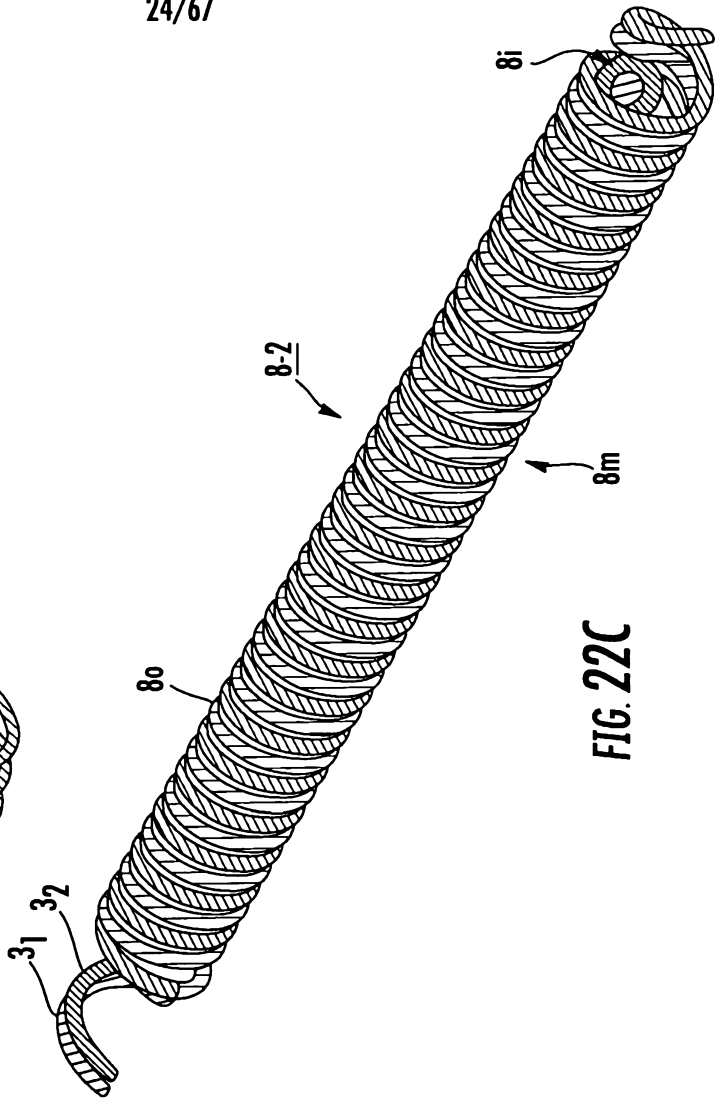
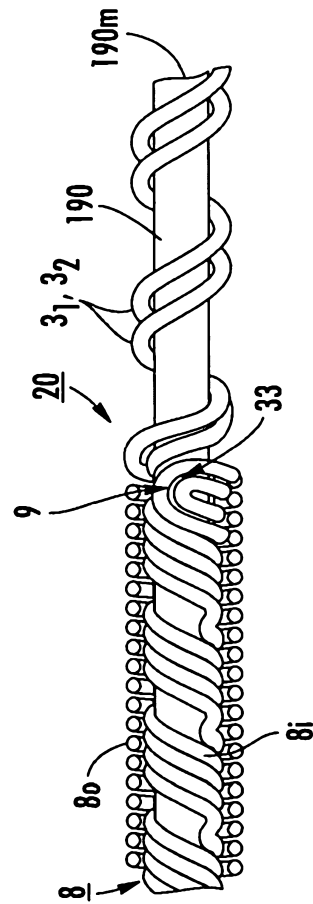
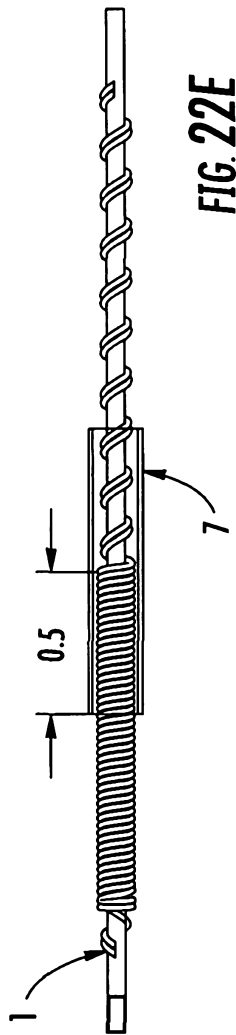
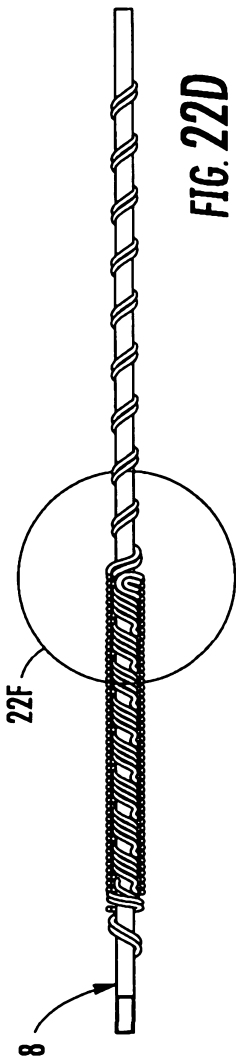
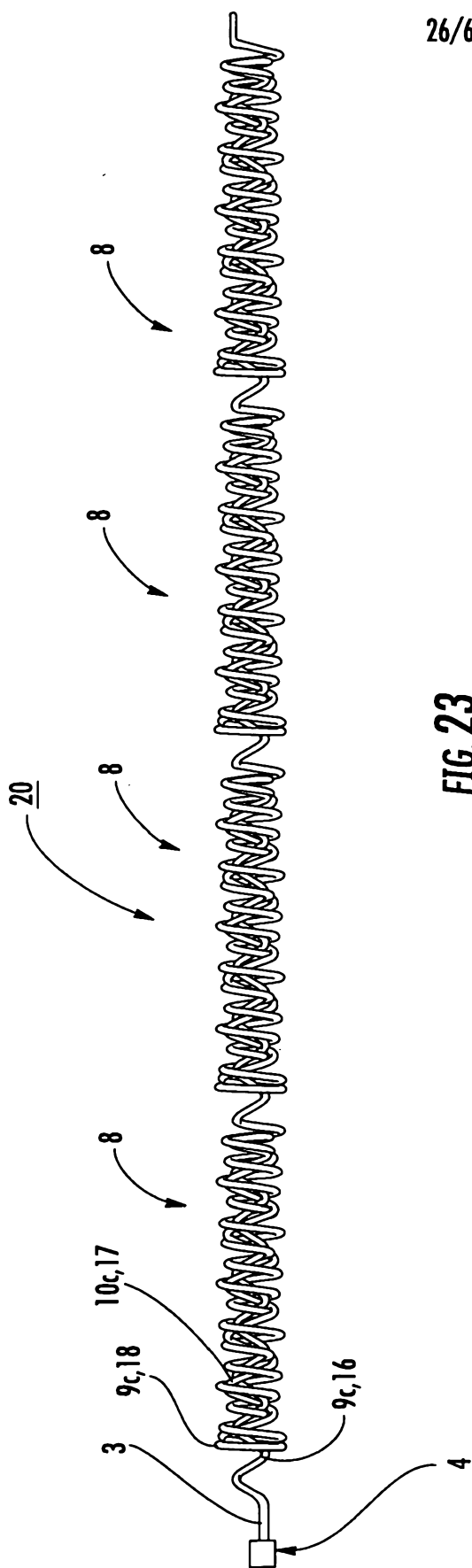

FIG. 22C





26/67

FIG. 23

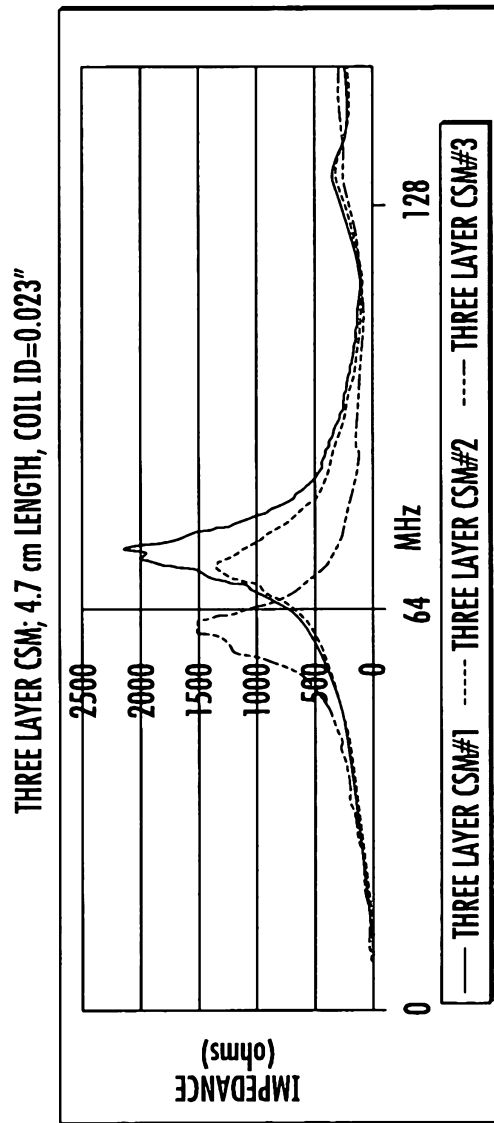

FIGURE 24A: IMPEDANCE CHARACTERISTIC OF A THREE LAYER CSM DESIGN.

FIG. 24A



FIG. 24B

IN VITRO TISSUE HEATING AT THE ELECTRODES OF A TRI LAYER CSM.
THE PEAK INPUT SAR OF THE SEQUENCE IS 4.3 W/kg.

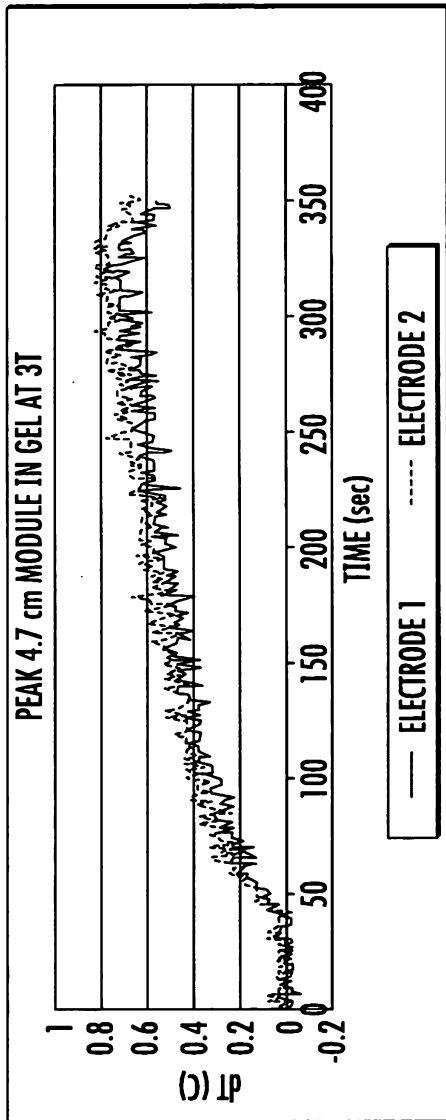

FIG. 25A

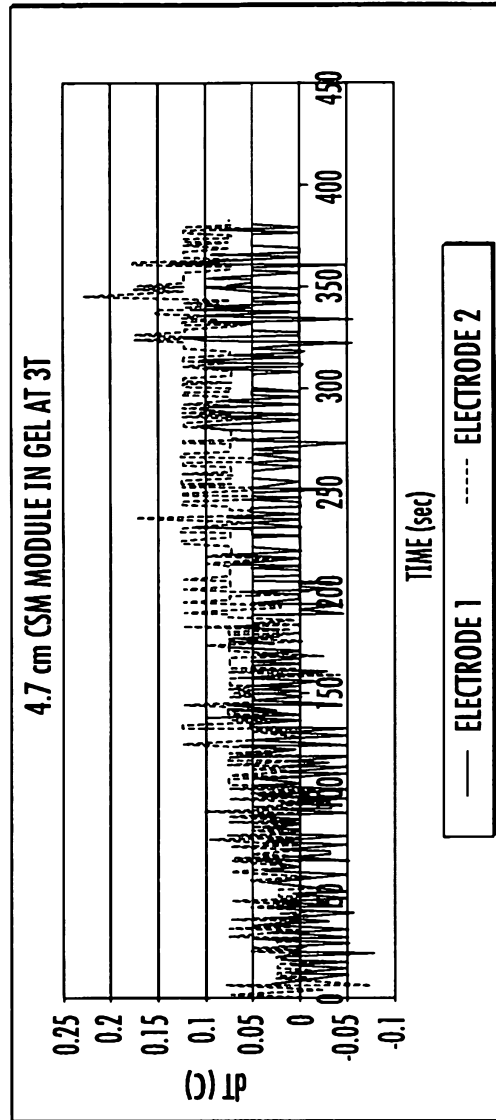
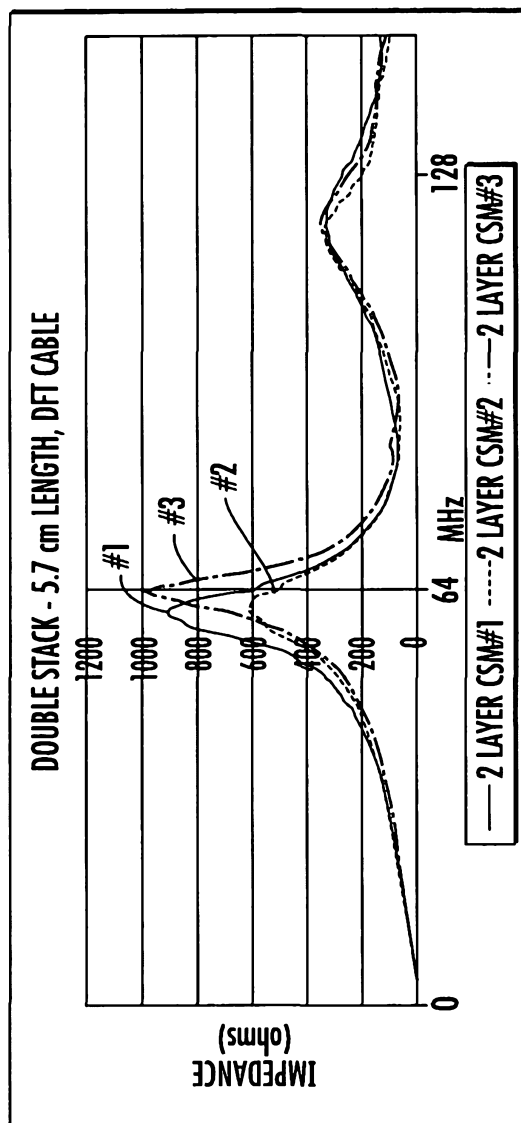
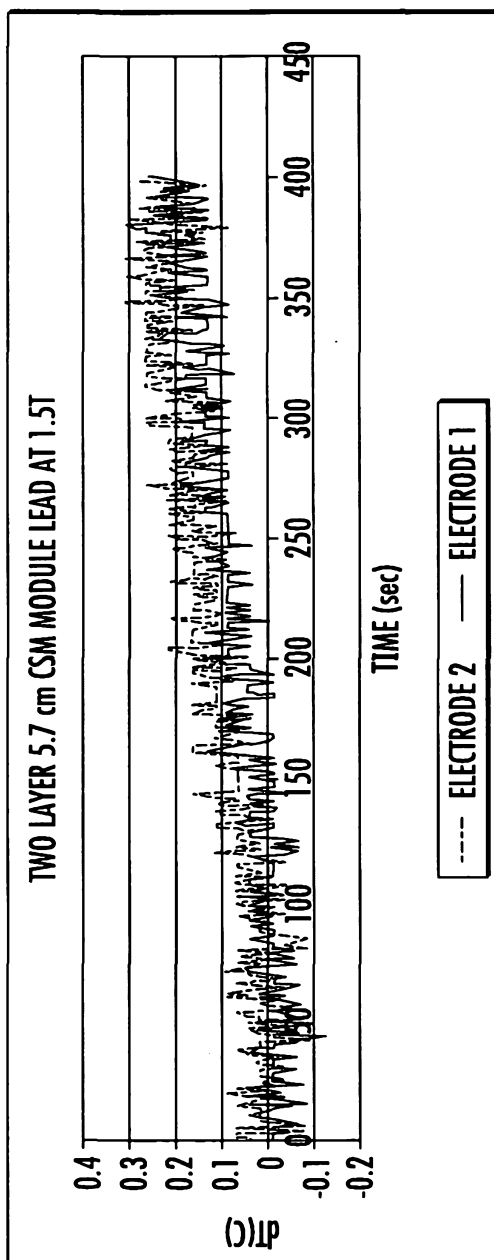

FIG. 25B



IMPEDANCE CHARACTERISTIC OF THE 2 LAYER CSM WITH FIRST CFS AND CBS COILED OPPOSITE TO EACH OTHER.

FIG. 26



IN VITRO TISSUE HEATING DATA - 2 LAYER LEAD. PEAK INPUT SAR OF THE SEQUENCE IS 4.3 W/kg

FIG. 27

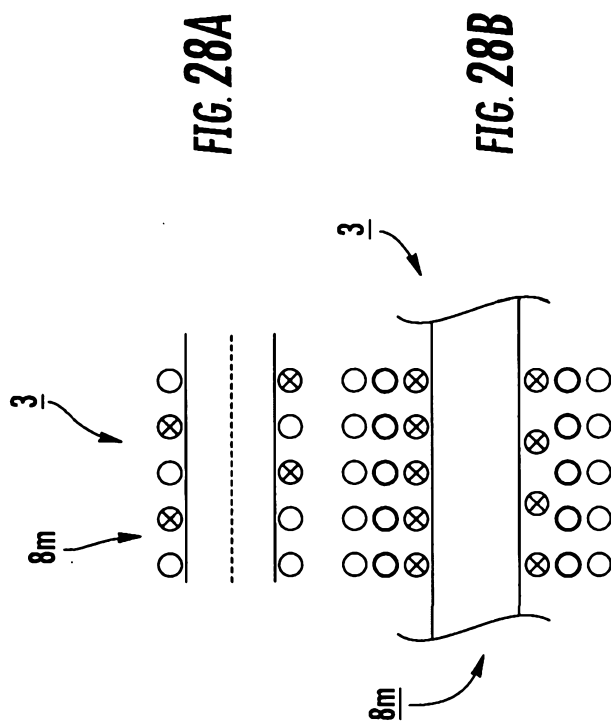

33/67

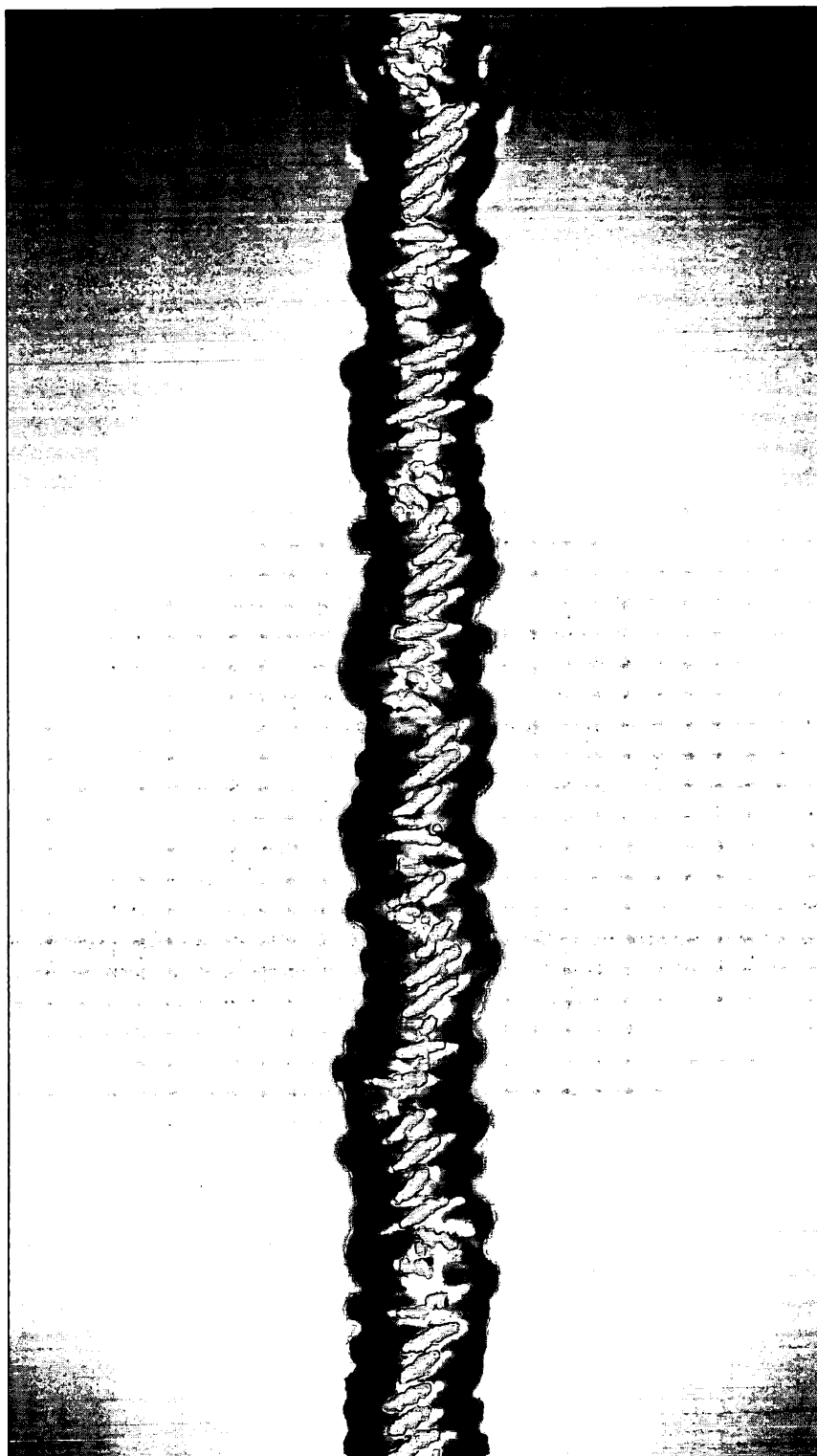

FIG. 29A



FIG. 29B

35/67

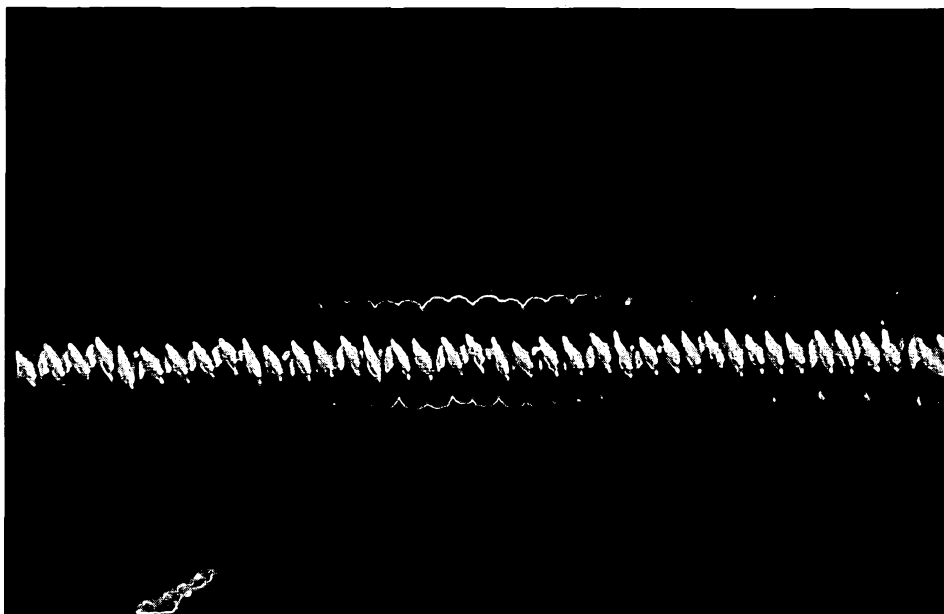

FIG. 29C

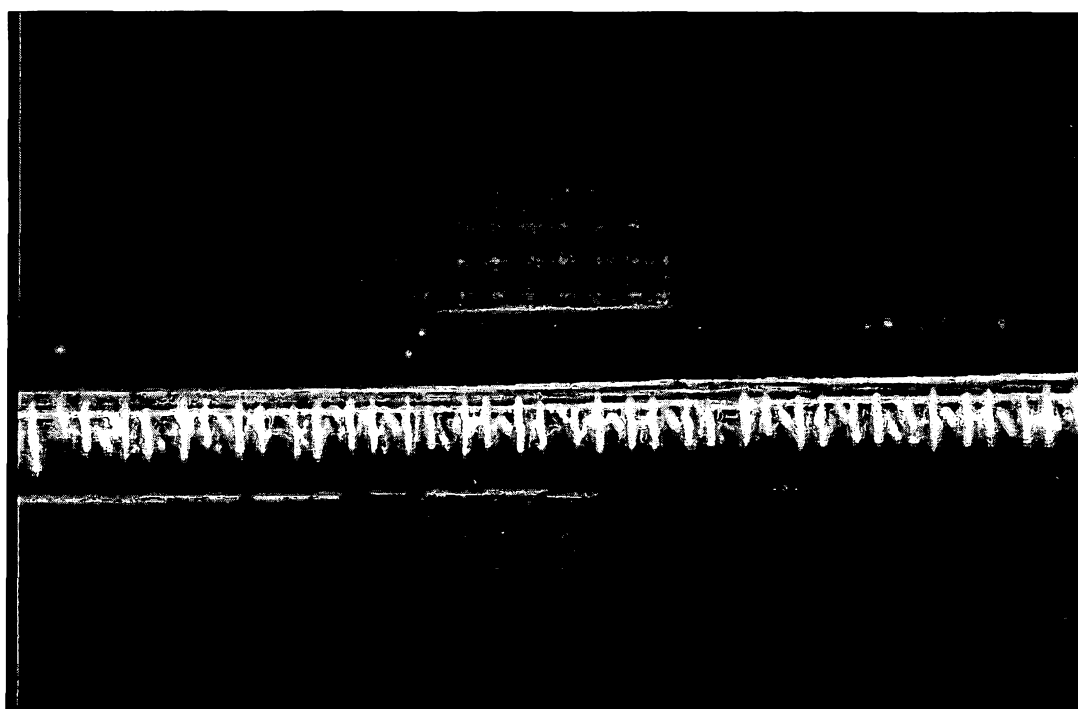

FIG. 29D

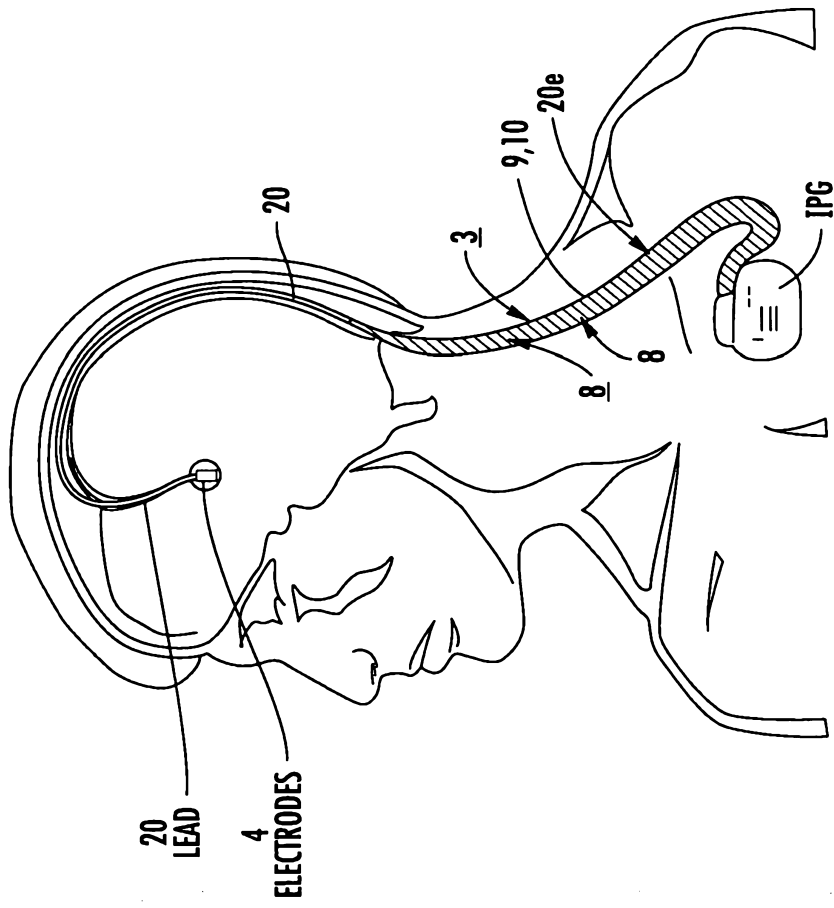

FIG. 30A

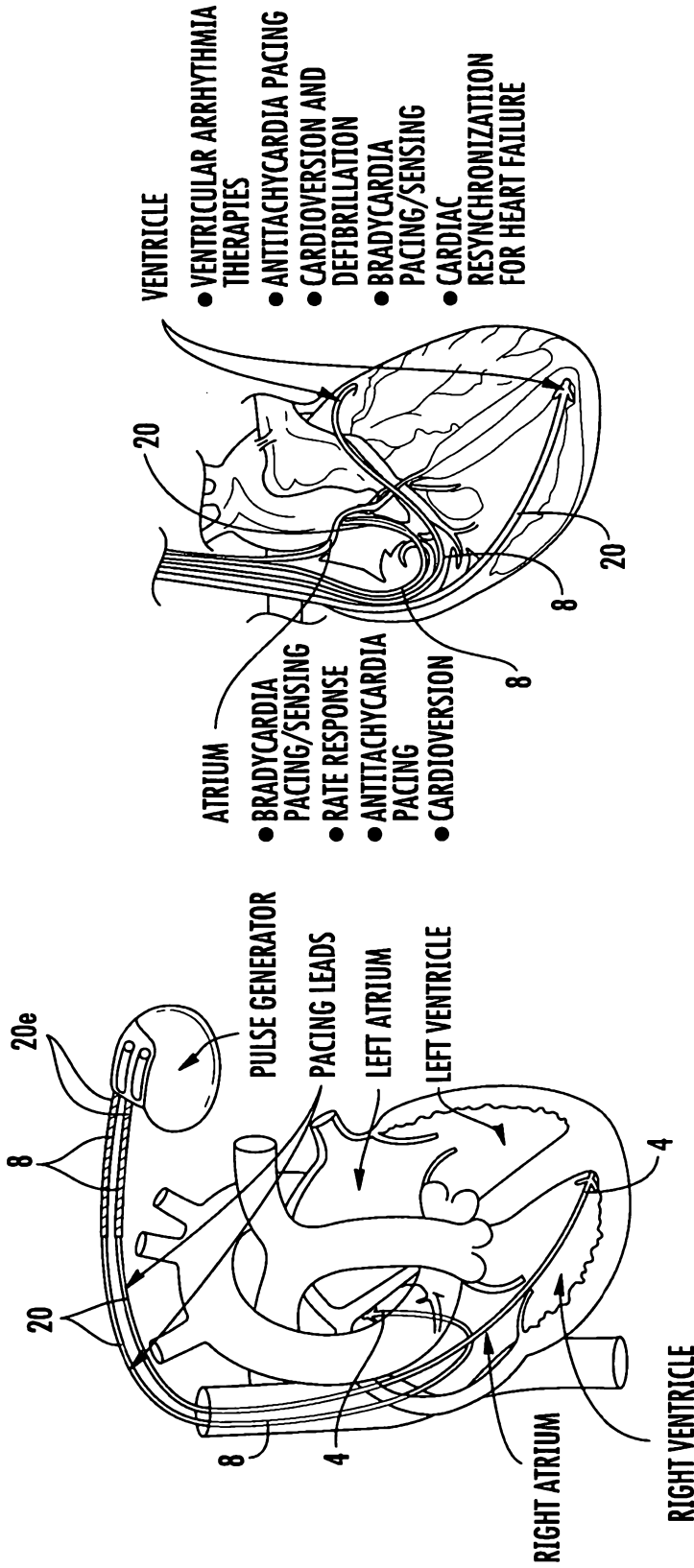

FIG. 30B

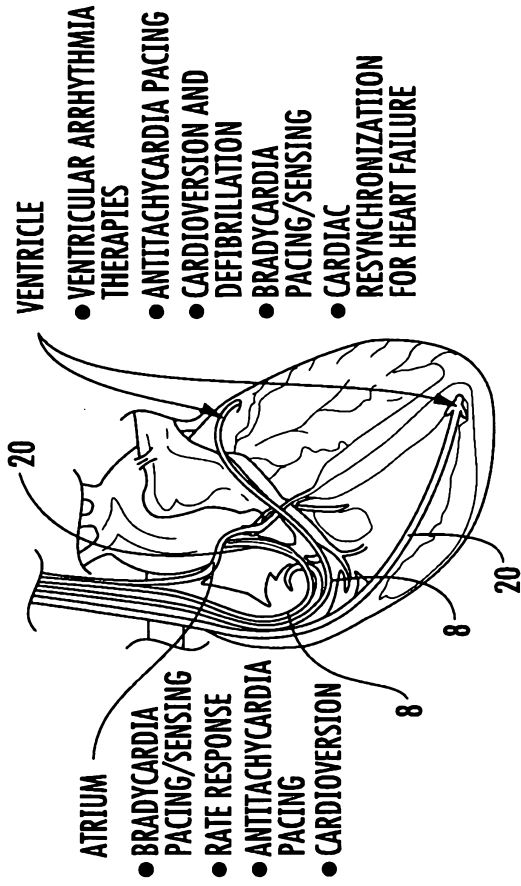

FIG. 30C

PACEMAKER AND ICD THERAPIES FOR TREATMENT OF CARDIAC ARRHYTHMIAS AND CARDIAC ARREST.
 RF/MRI SAFE BRADYARRHYTHMIA
 AND TACHYARRHYTHMIA LEAD SYSTEMS

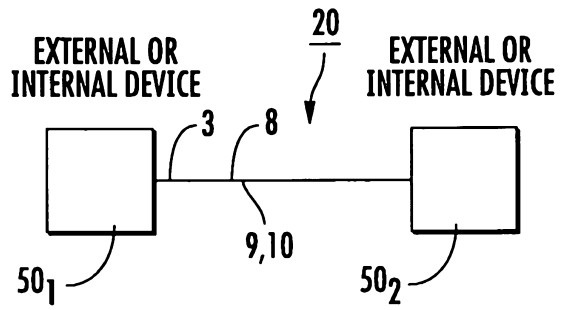

FIG. 30D

39/67

FIG. 30E

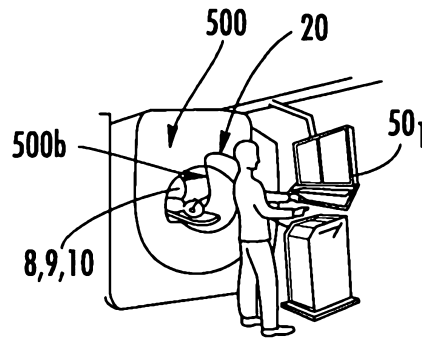

FIG. 30F

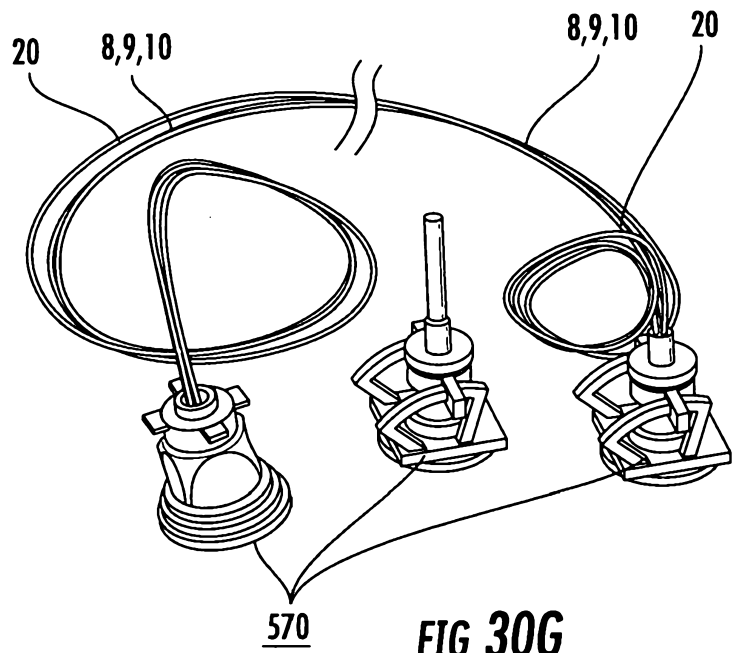
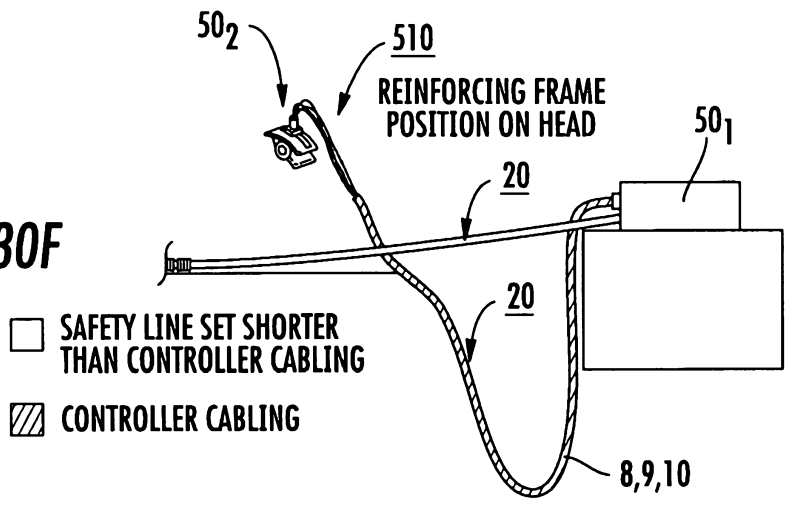

FIG. 30G

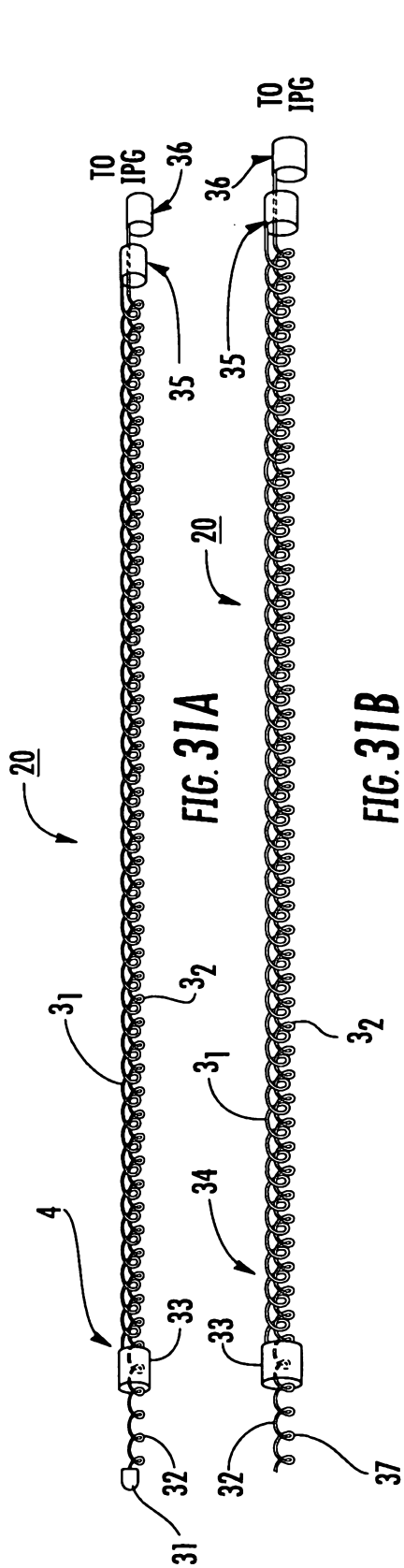

FIG. 31A

FIG. 31B

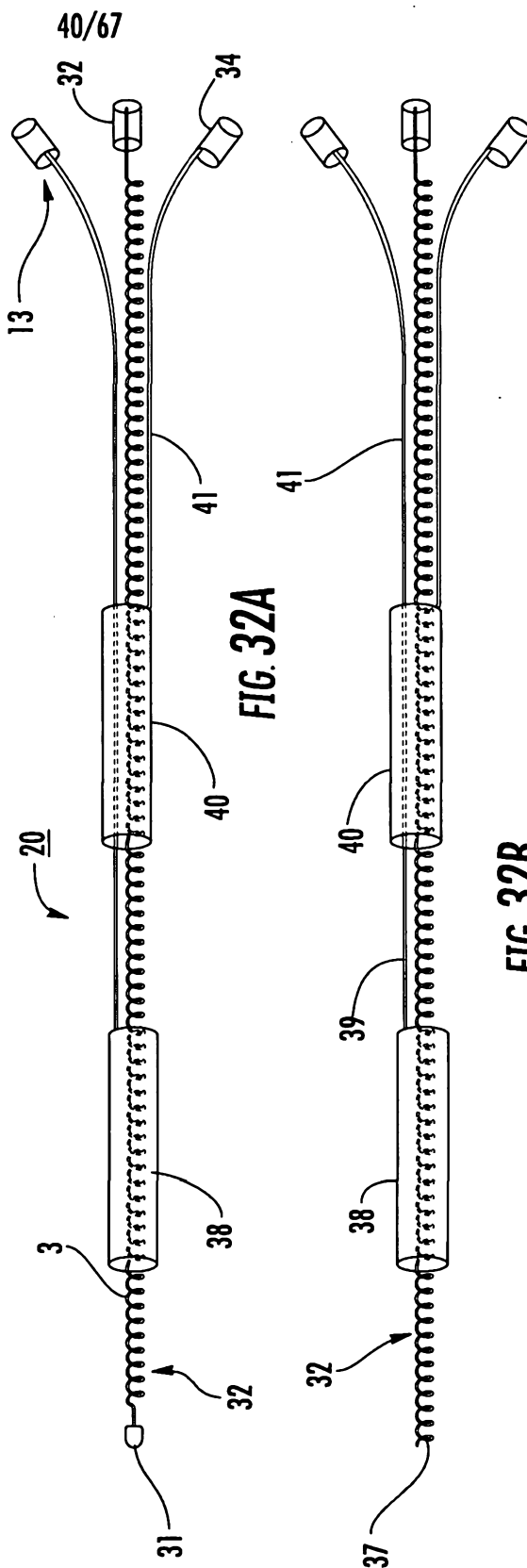

FIG. 32A

FIG. 32B

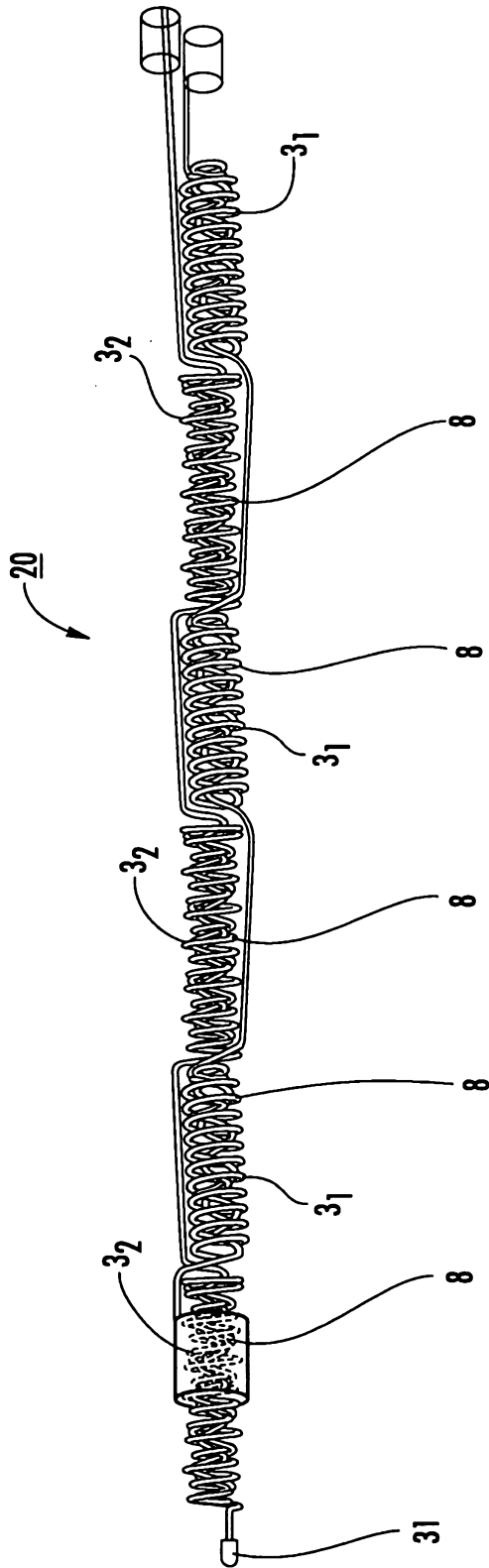
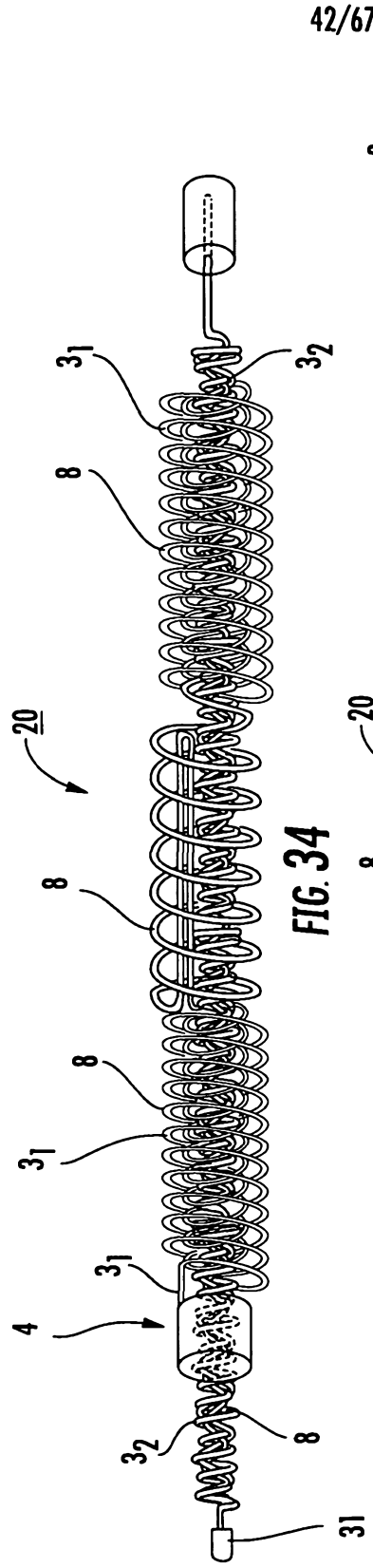
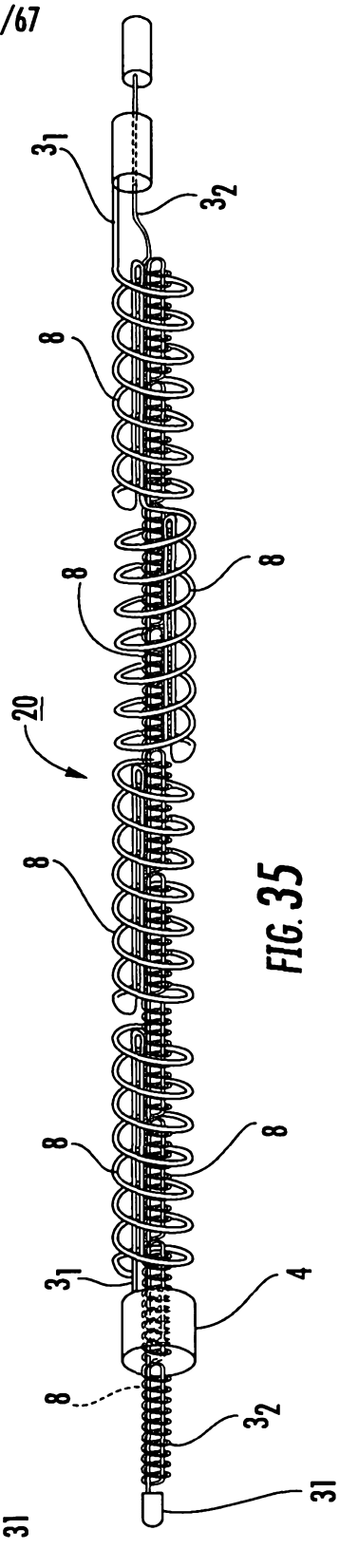

FIG. 33



42/67



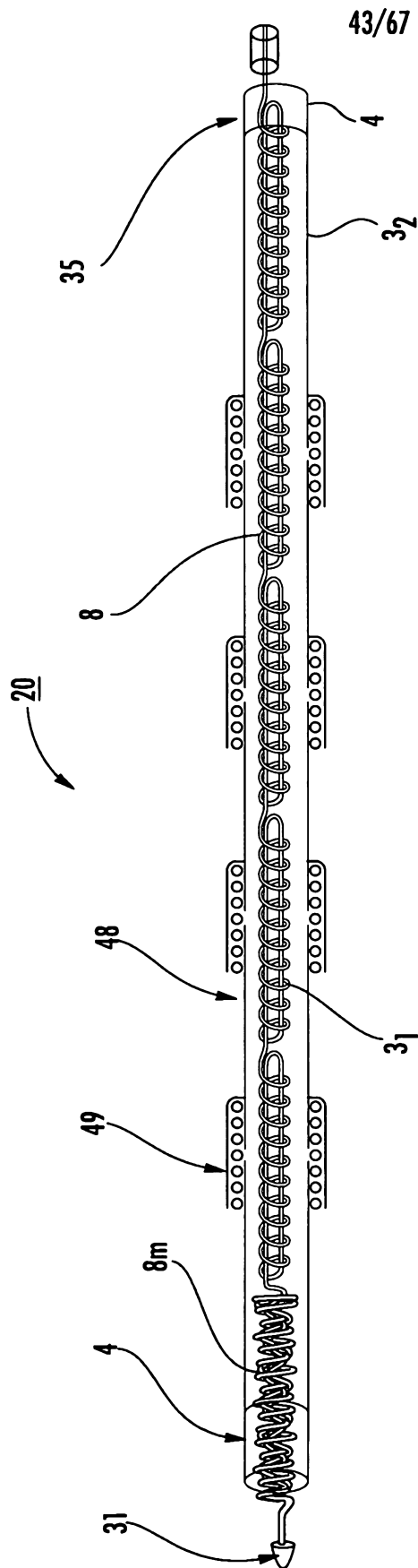

FIG. 36

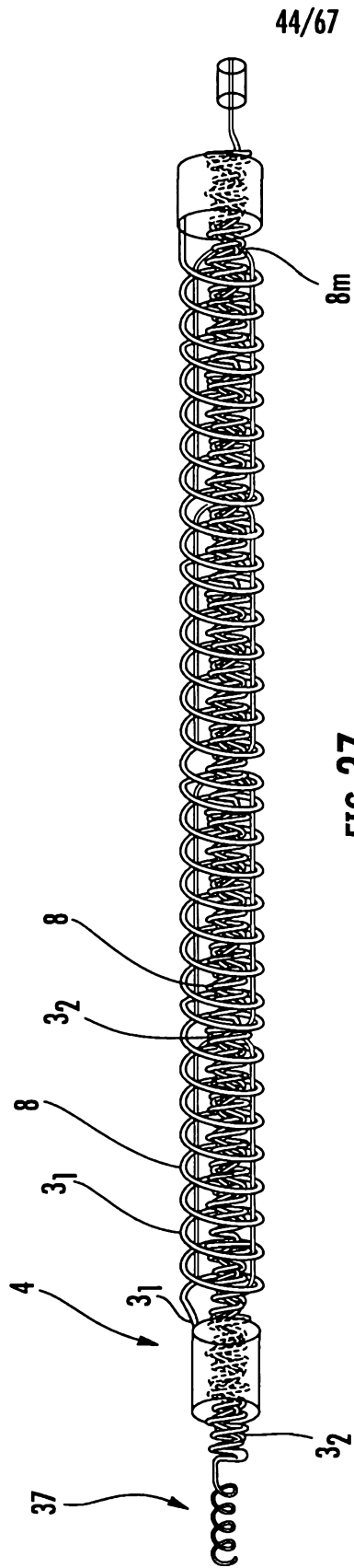

FIG. 37

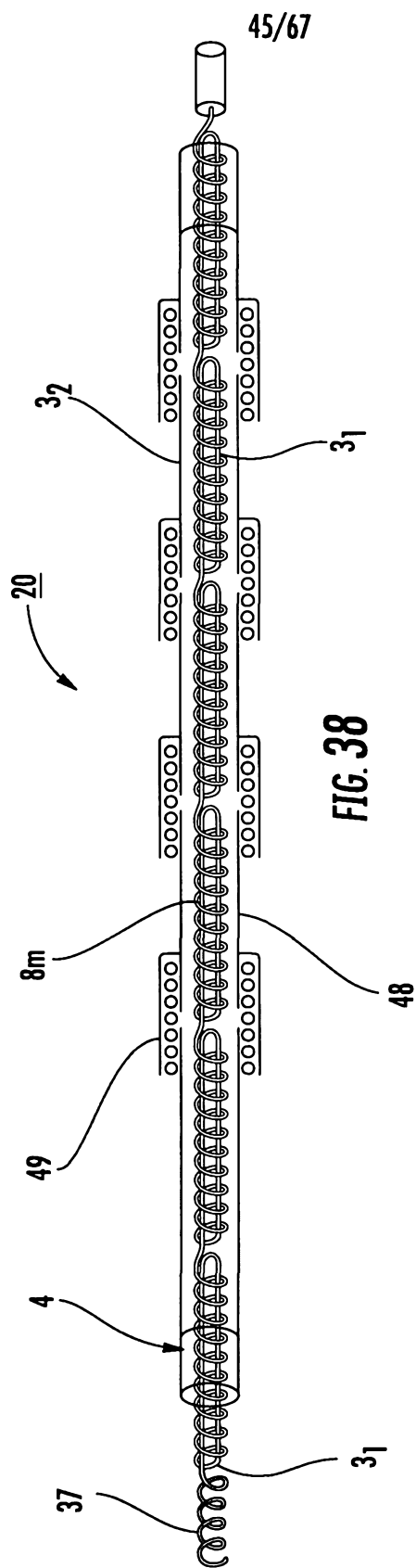

FIG. 38

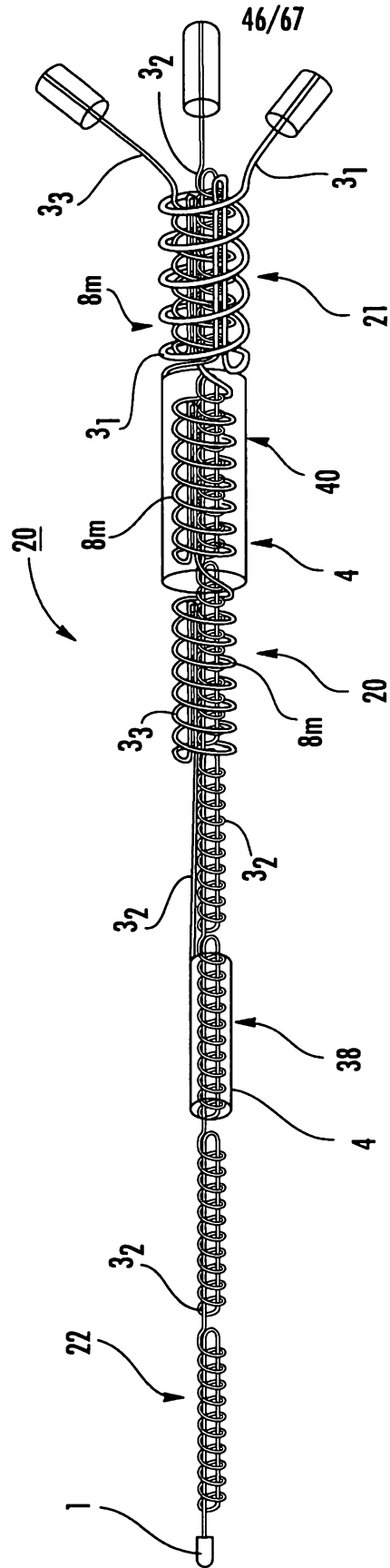

FIG. 39

47/67

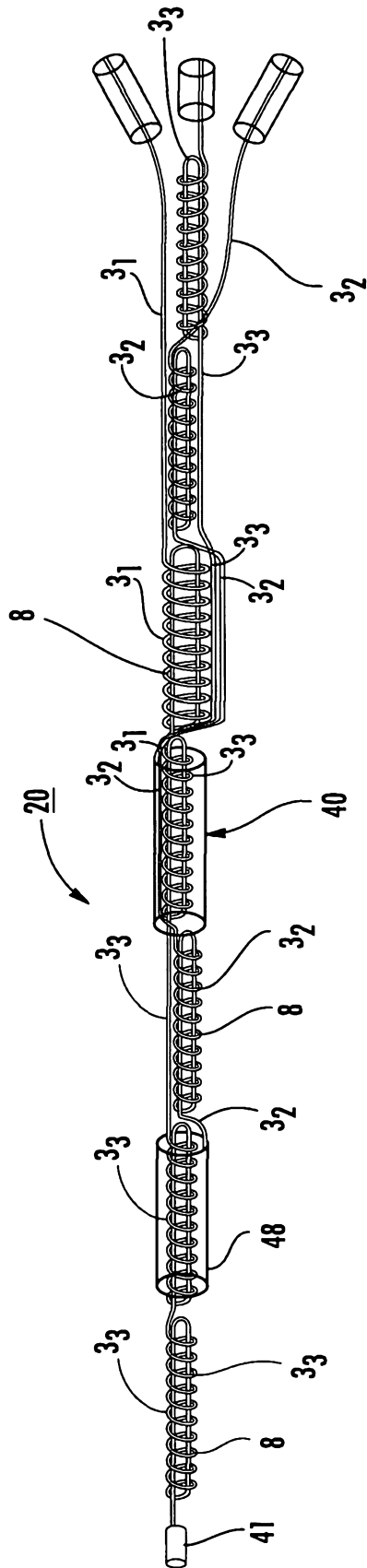

FIG. 40

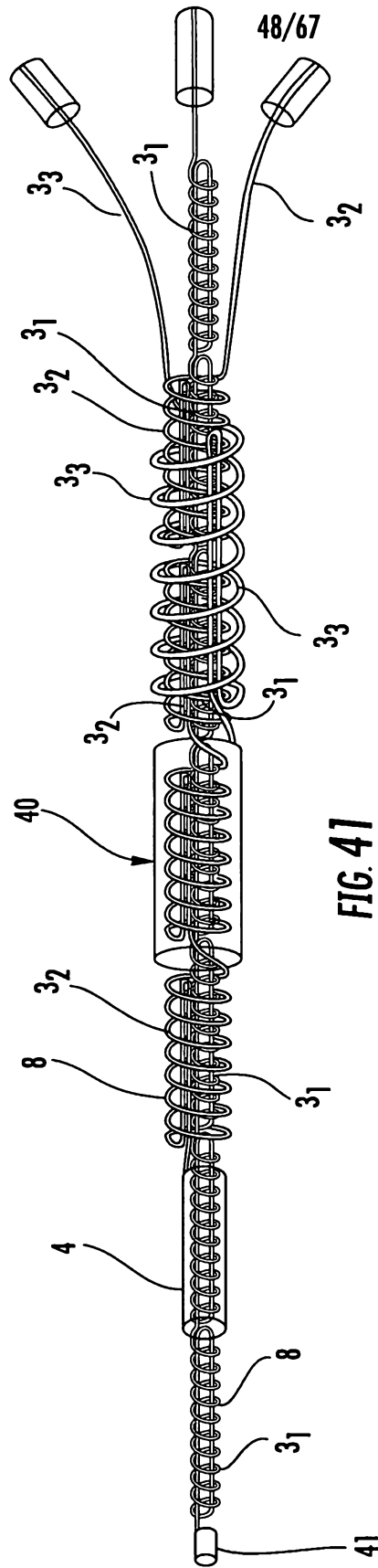

FIG. 41

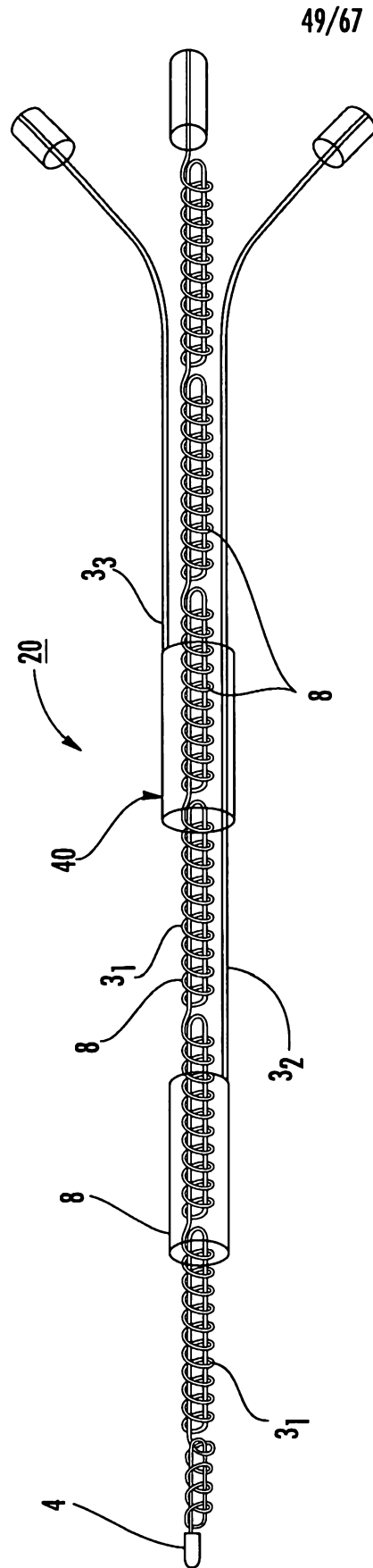

FIG. 42

50/67

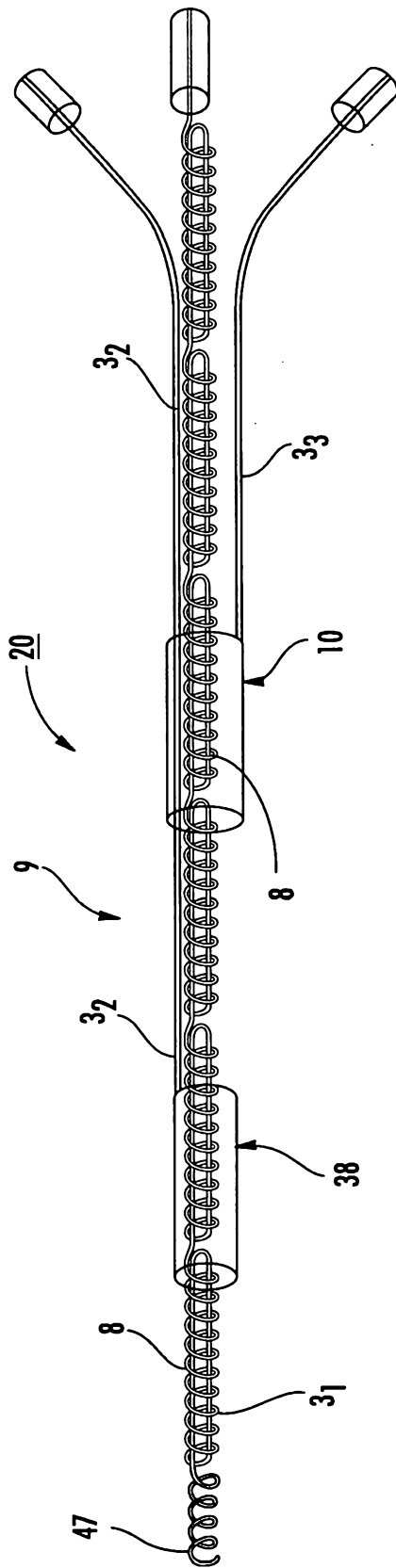

FIG. 43

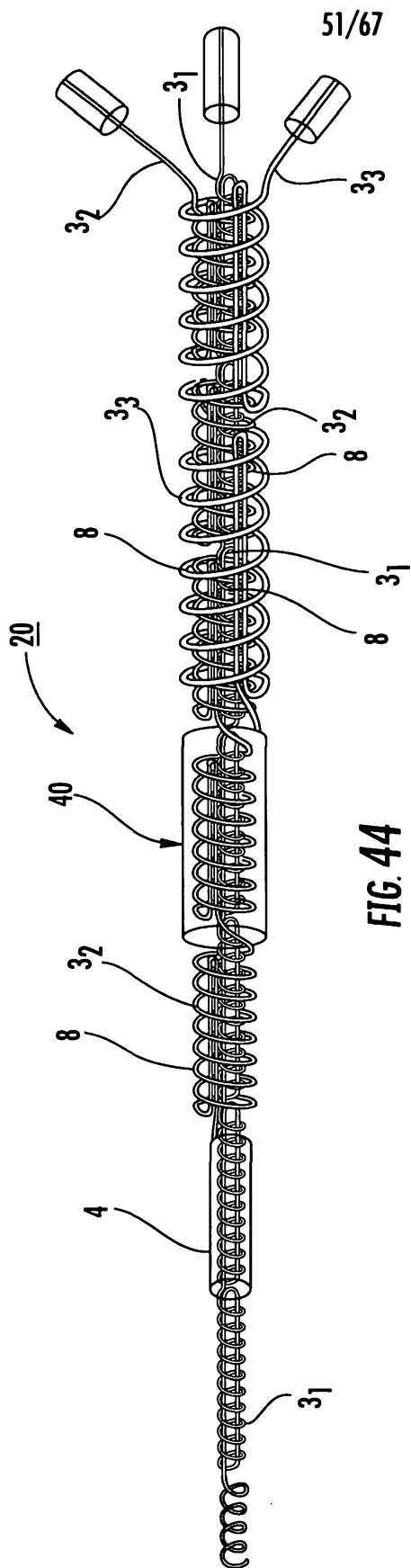

FIG. 44

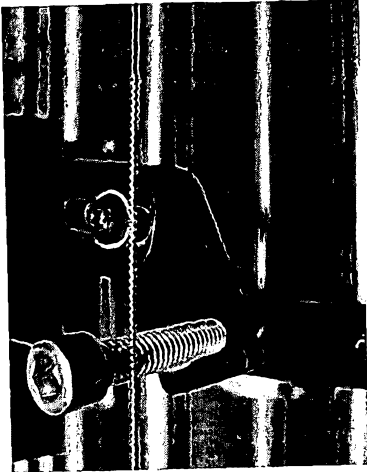

FIG. 45C

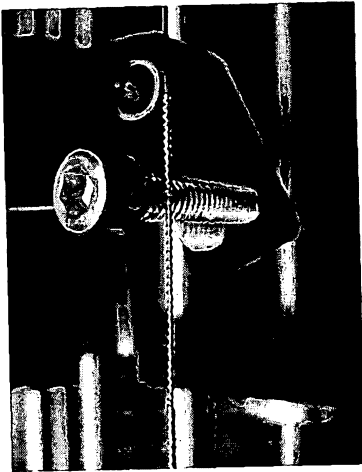

FIG. 45B

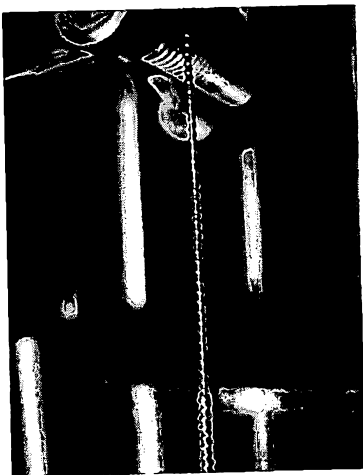

FIG. 45A

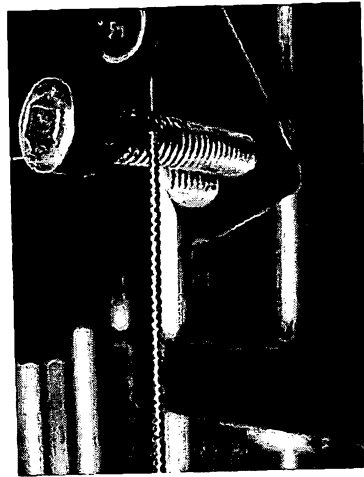

FIG. 45E

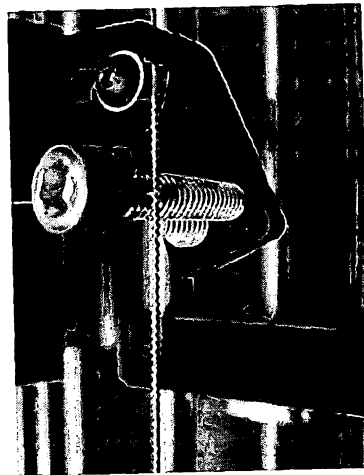

FIG. 45D

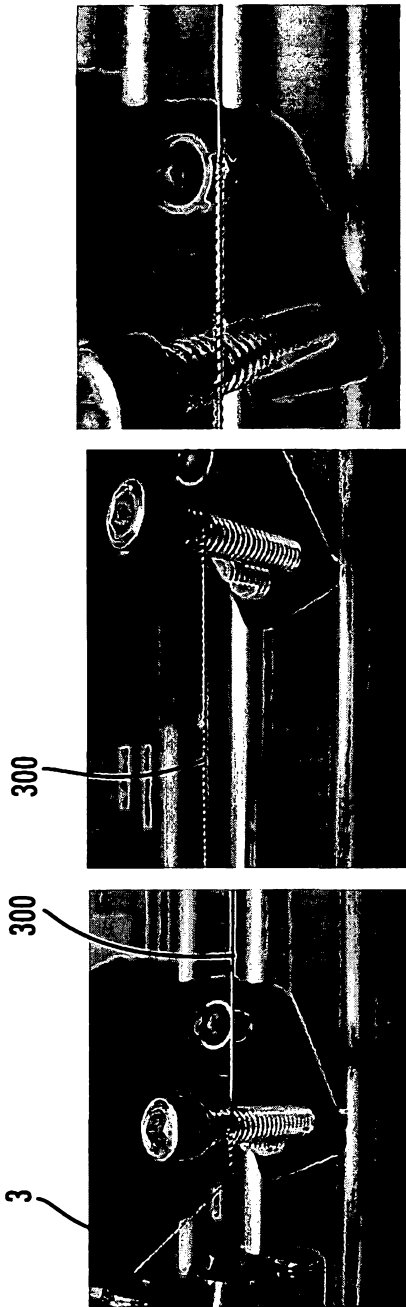

FIG. 46A

FIG. 46B

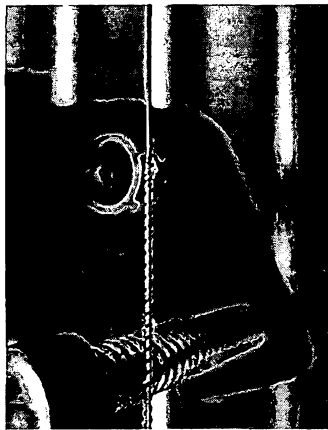

FIG. 46C

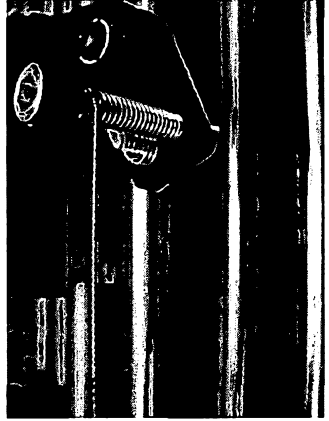

FIG. 46F

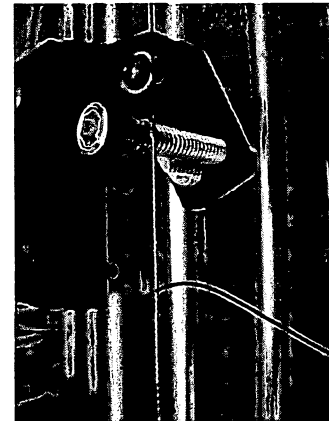

FIG. 46E

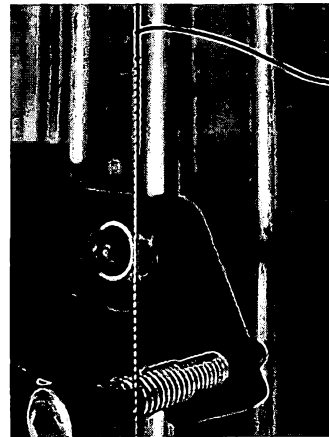

FIG. 46D



FIG. 47C

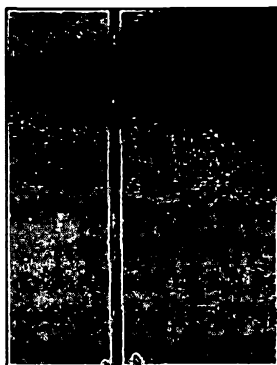

FIG. 48C

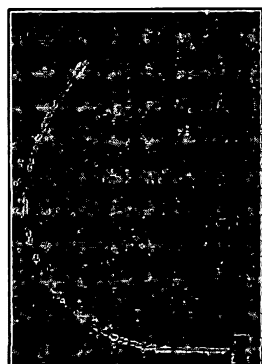

FIG. 47B

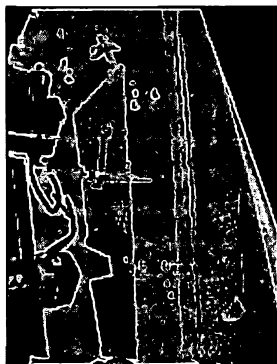

FIG. 48B

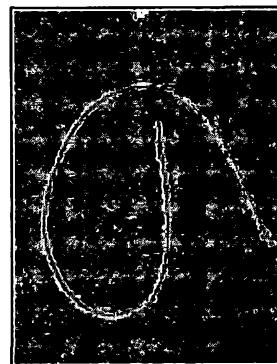

FIG. 49

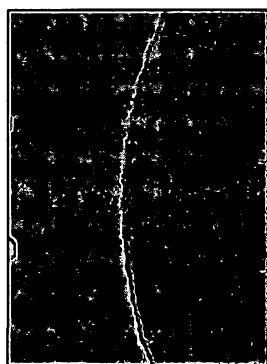

FIG. 47A

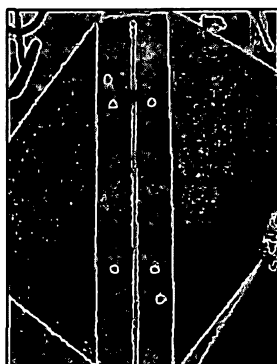

FIG. 48A

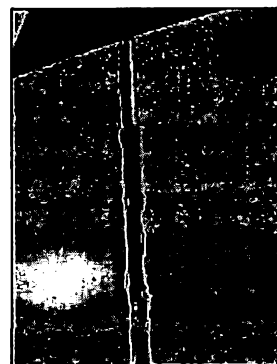
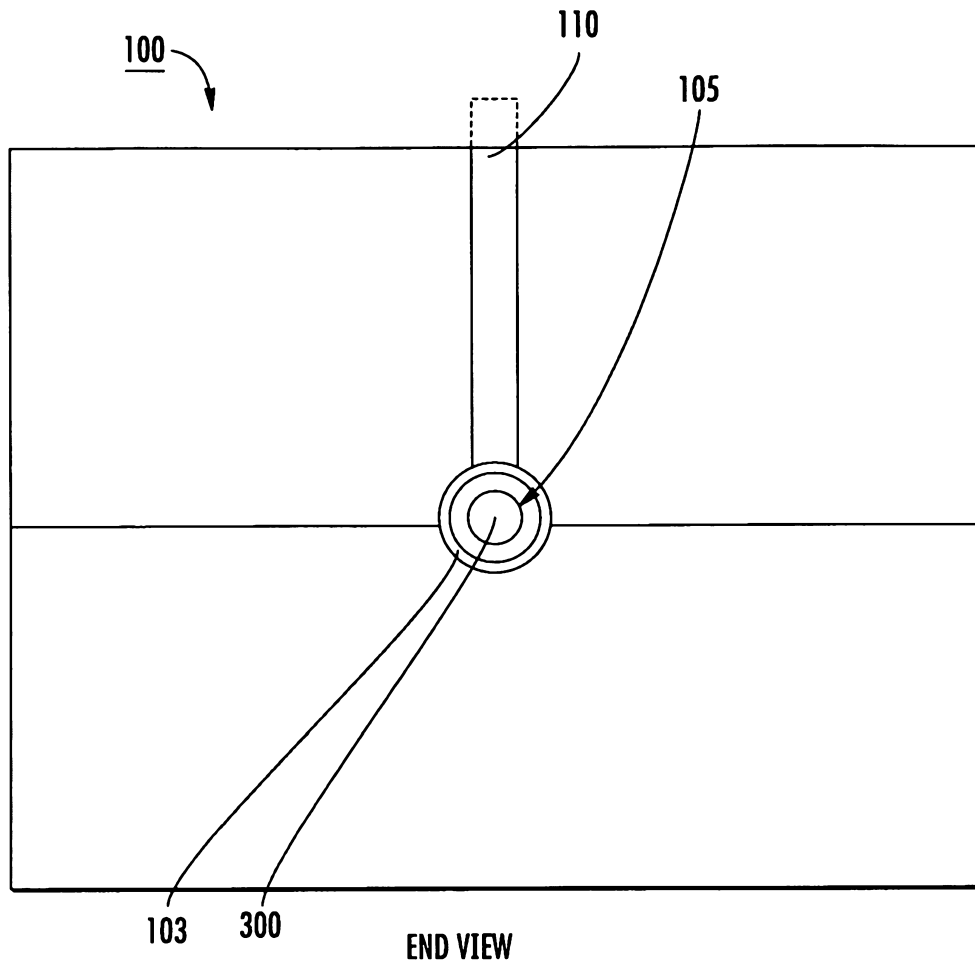

FIG. 48D

56/67



END VIEW

FIG. 51

57/67

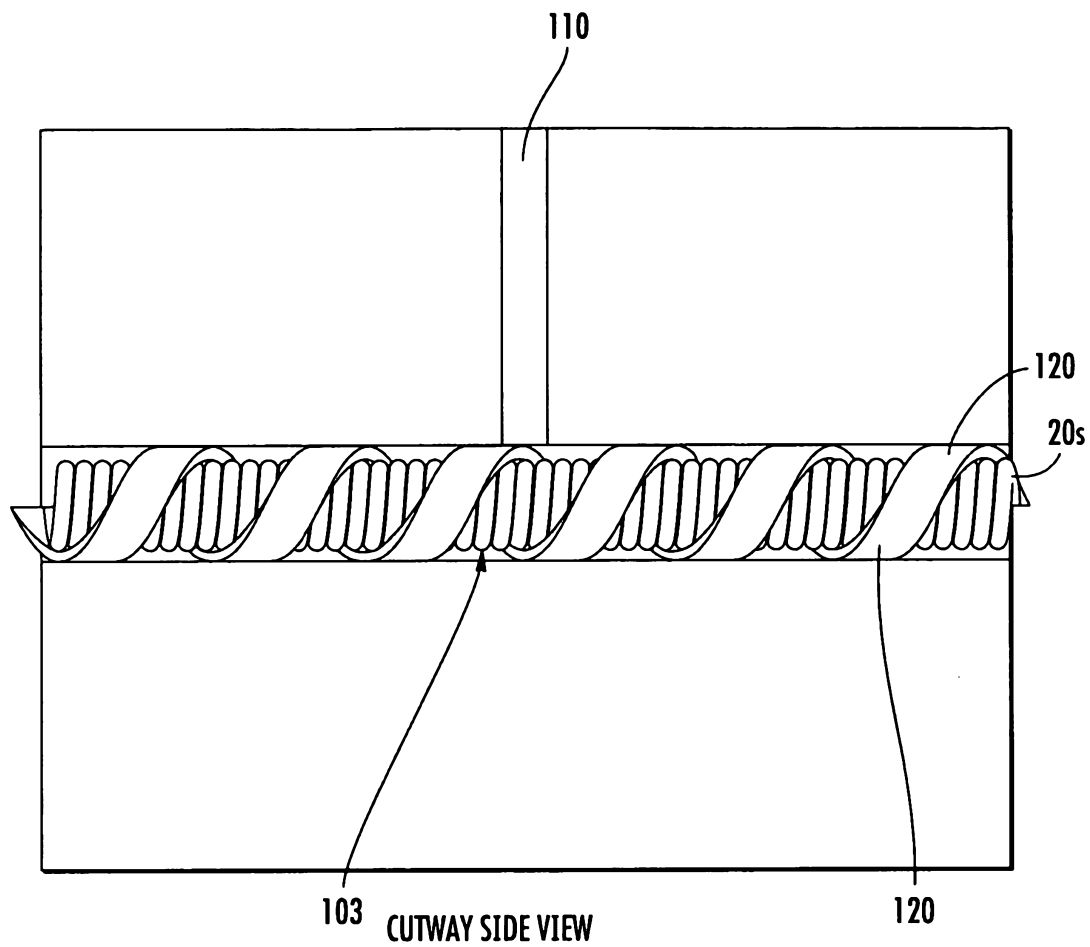

FIG. 52

58/67

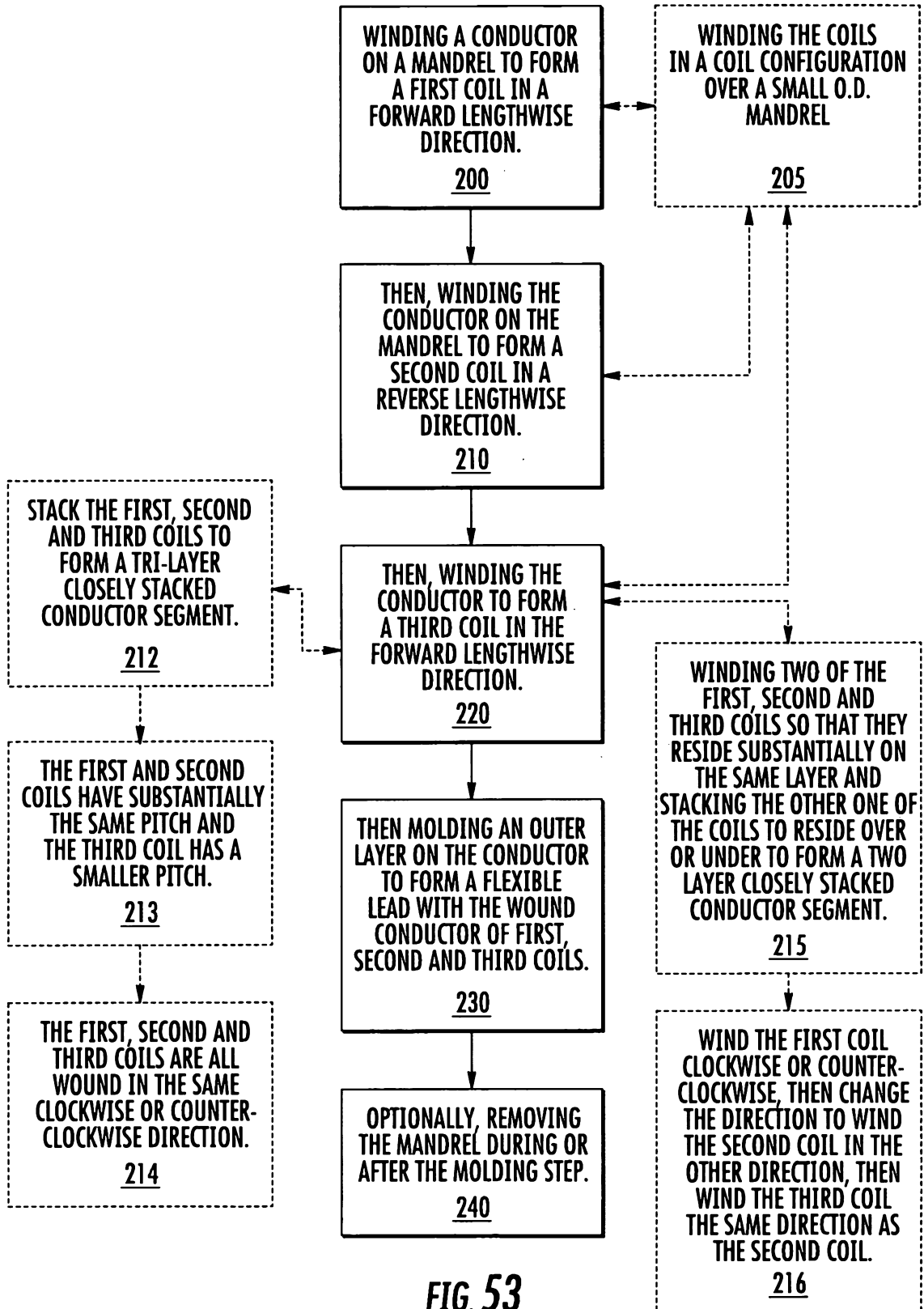
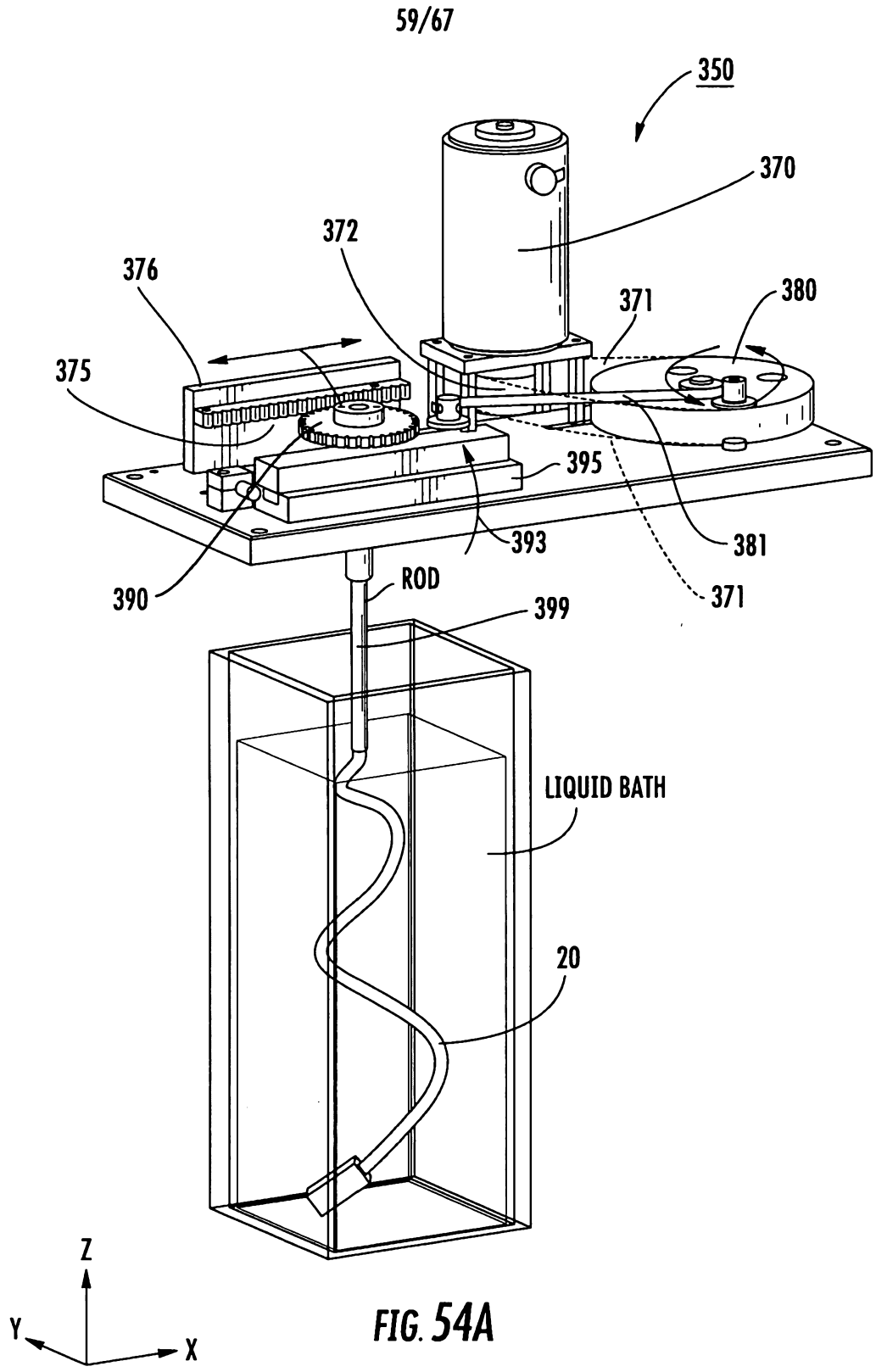

FIG. 53



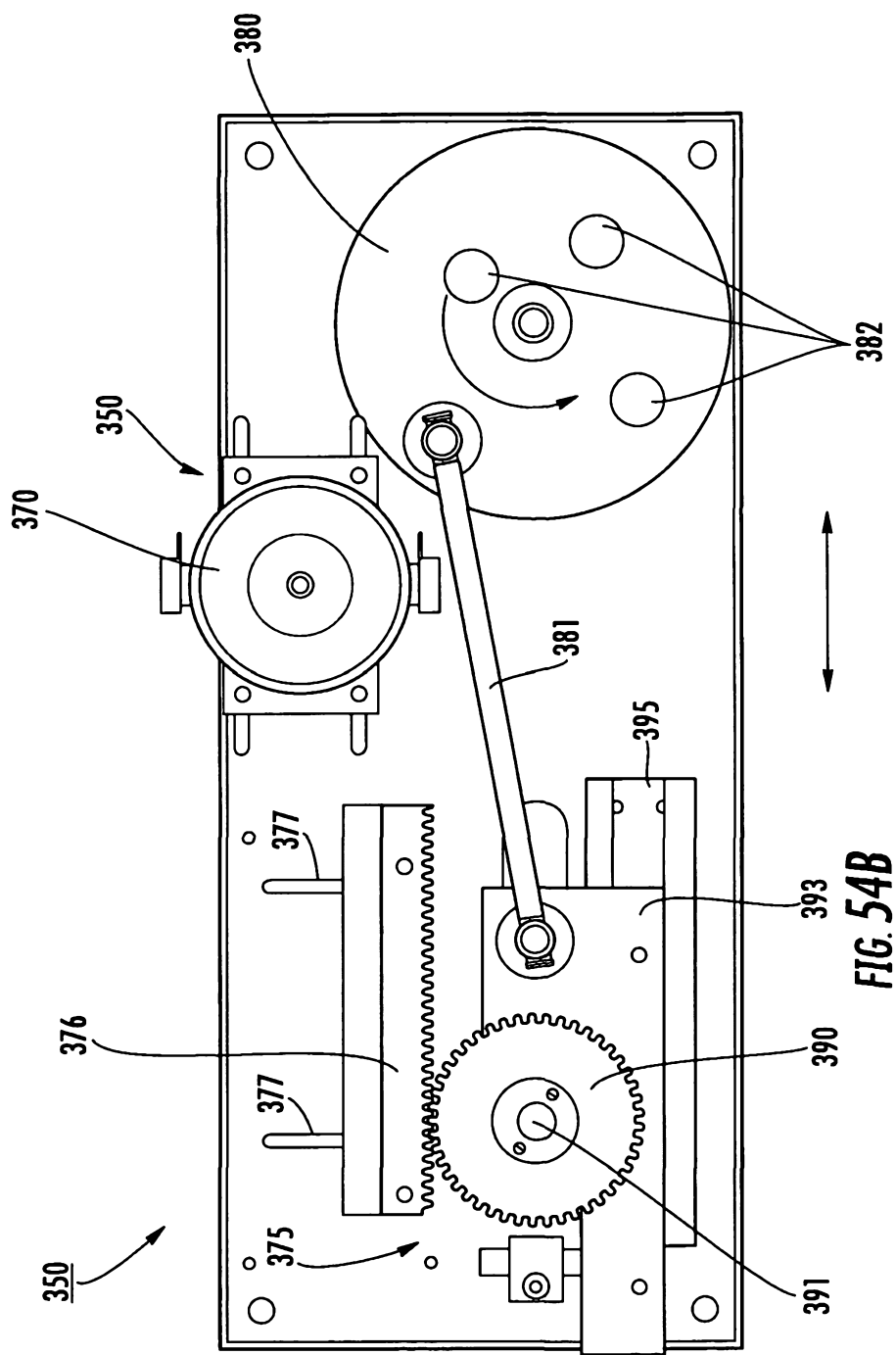

FIG. 54B

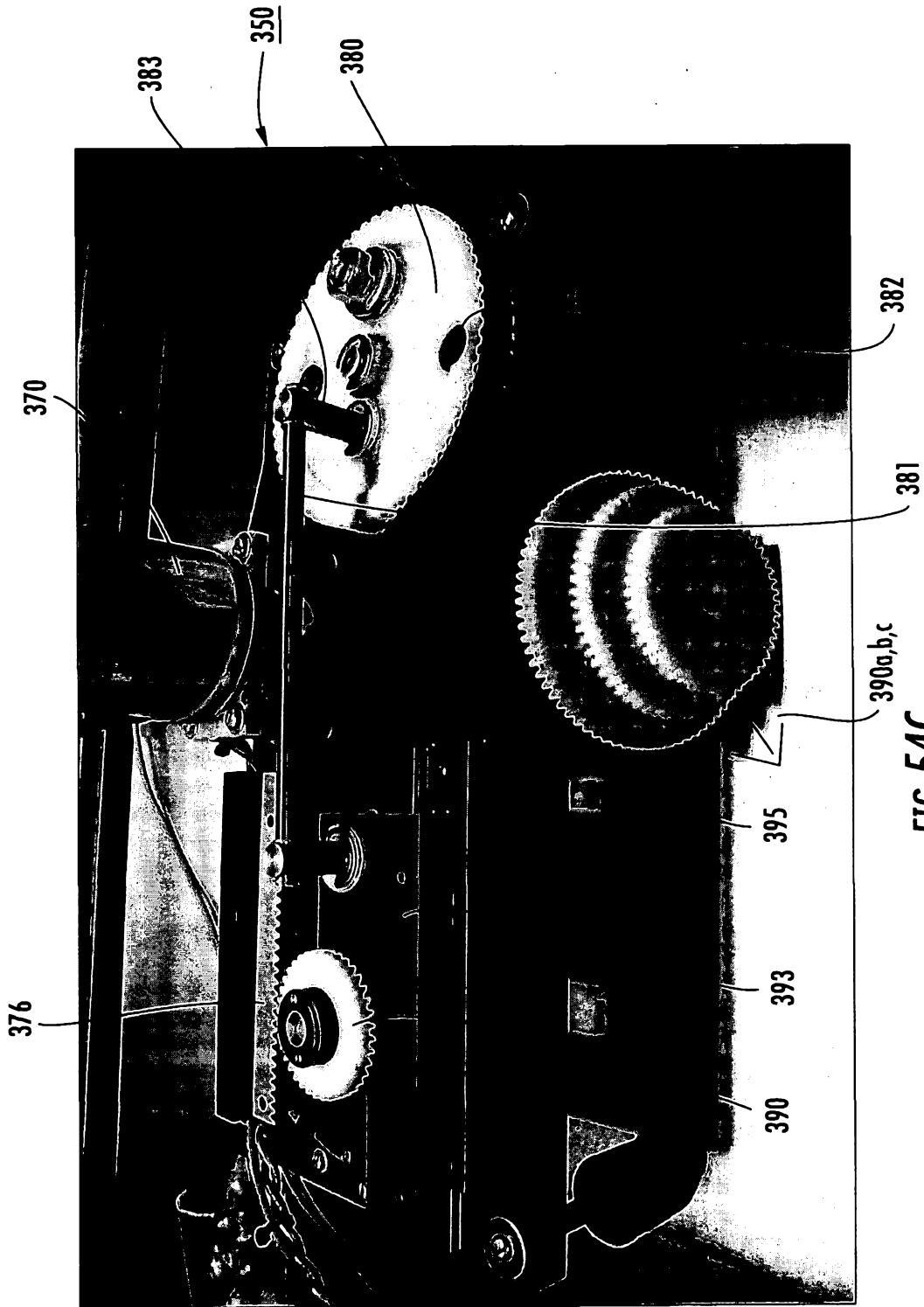

FIG. 54C

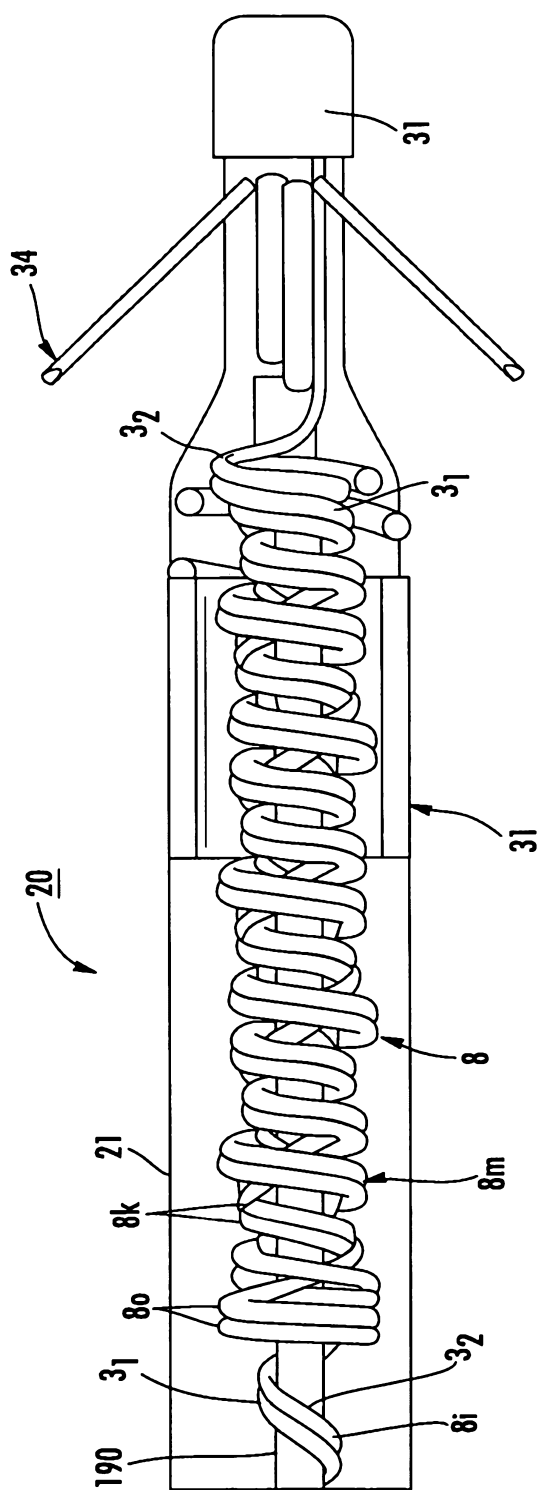

FIG. 55A

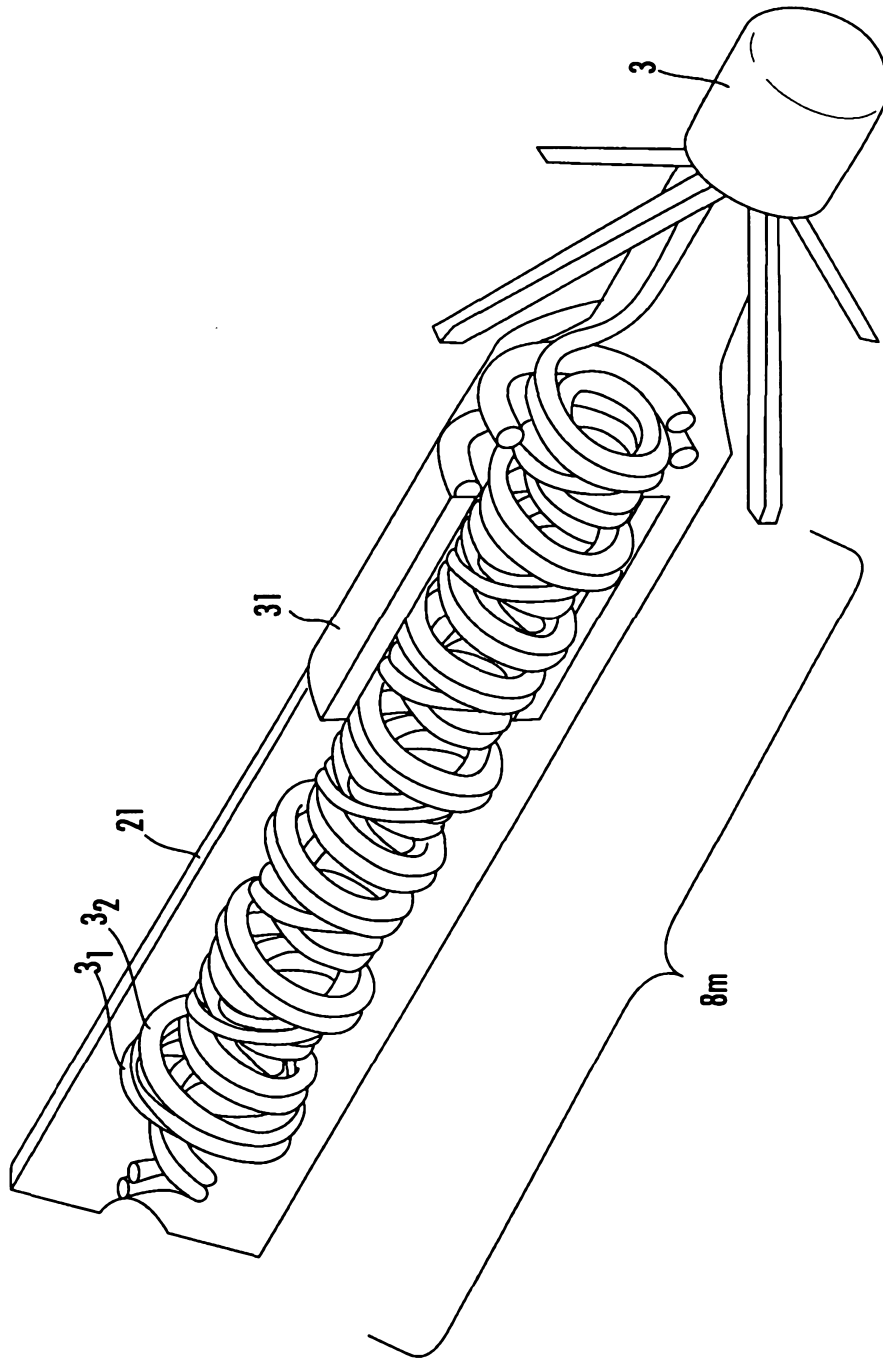

FIG. 55B

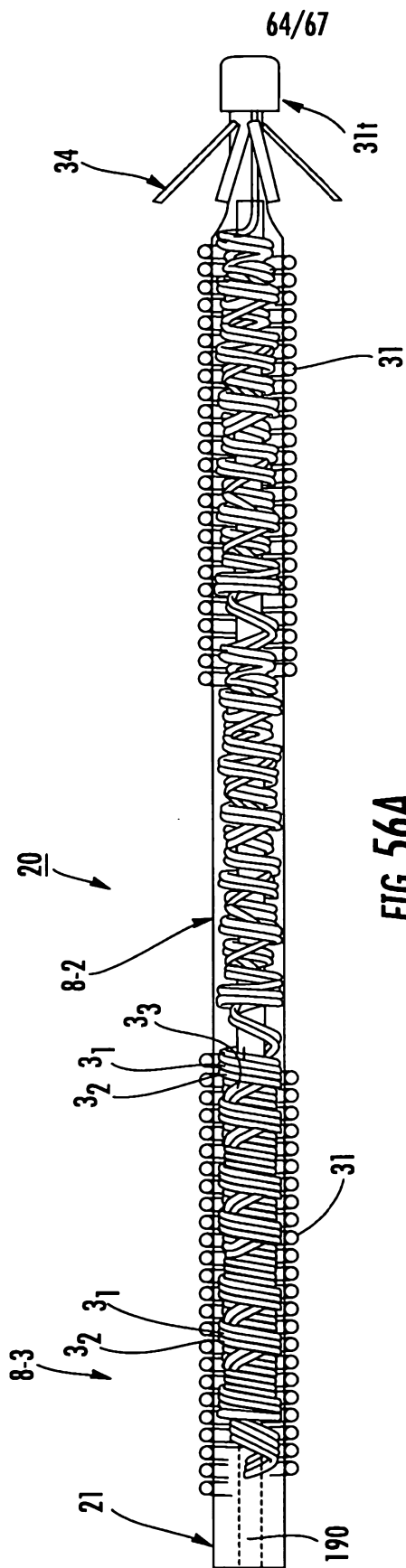

FIG. 56A

65/67

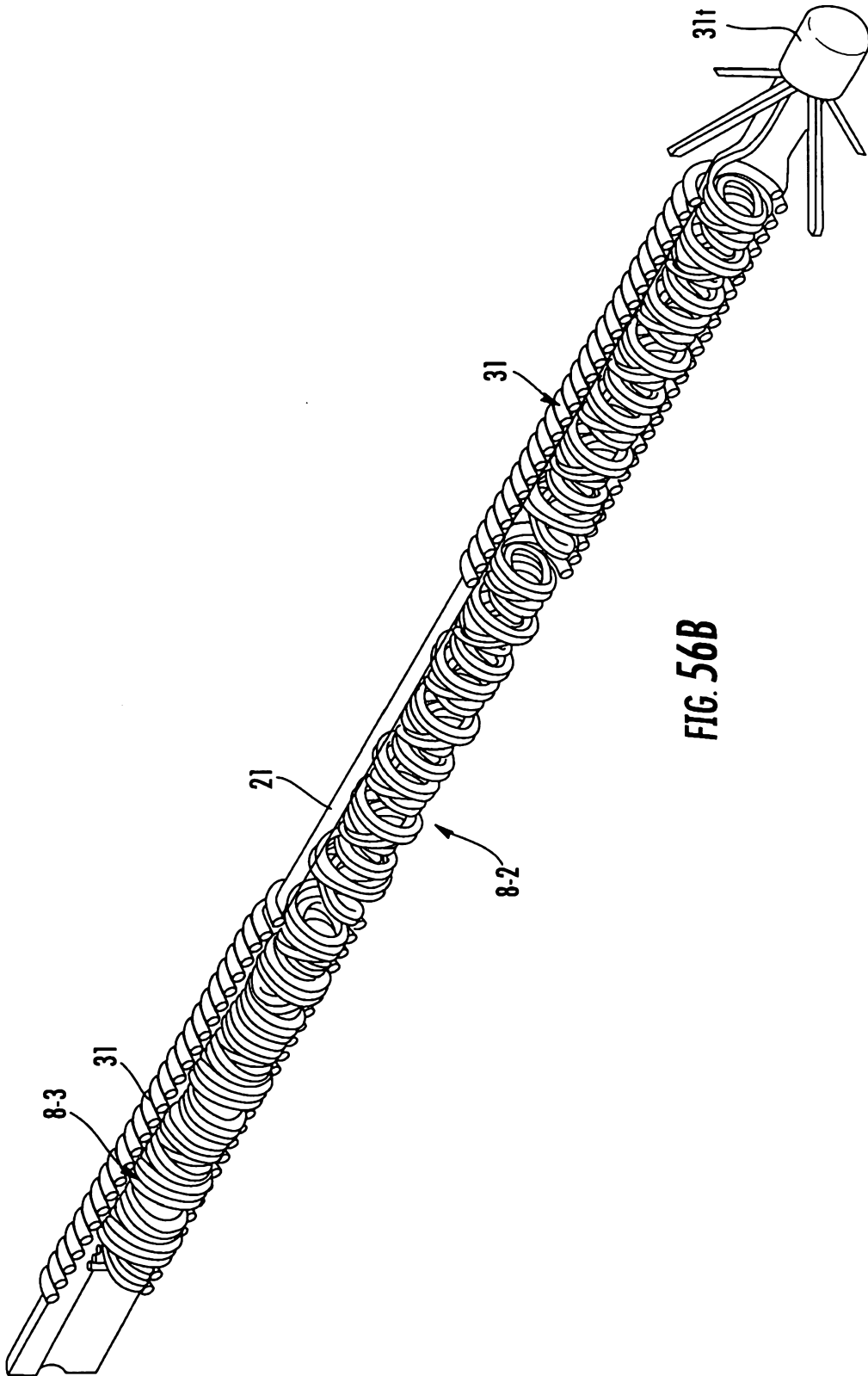
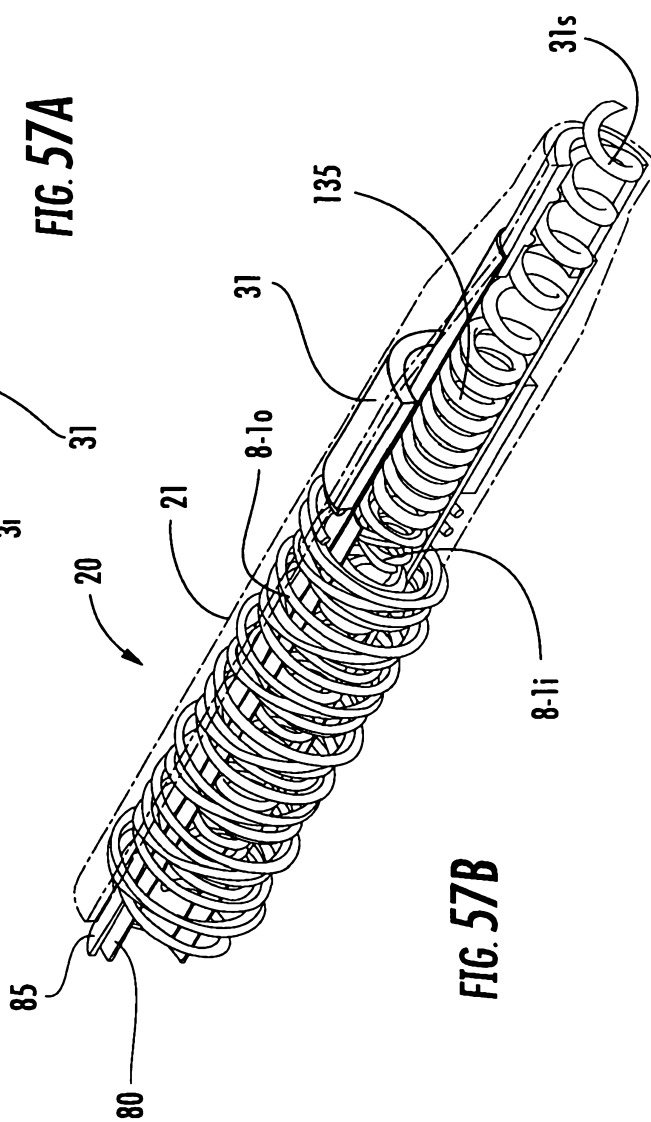
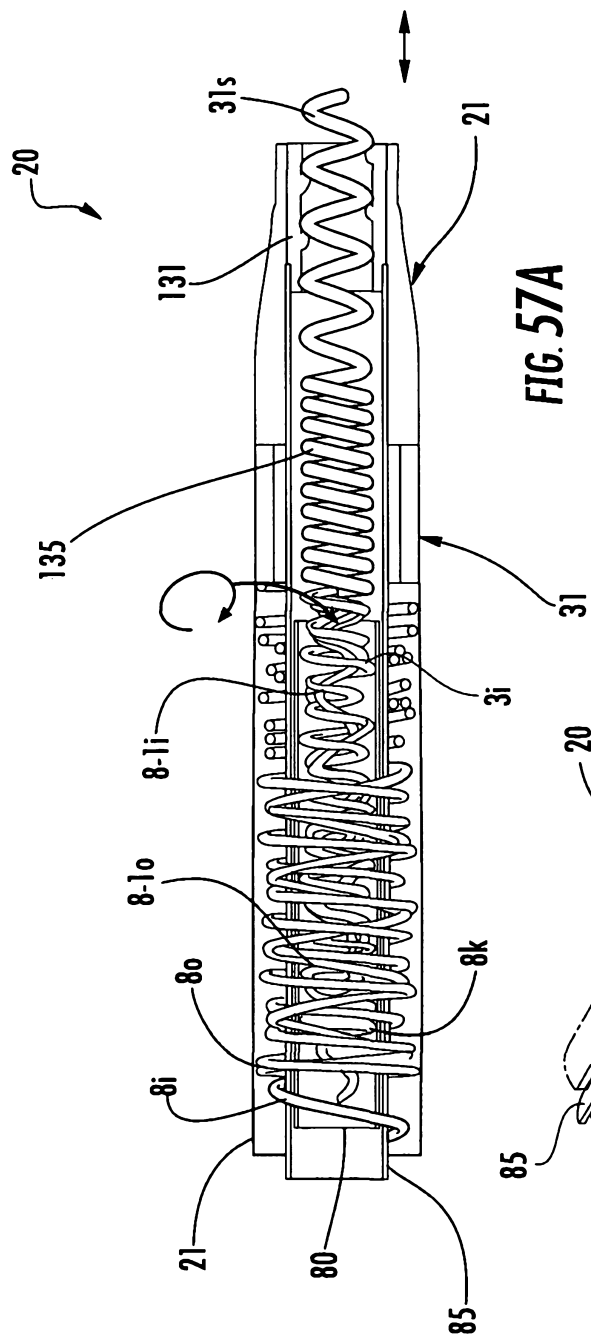

FIG. 56B



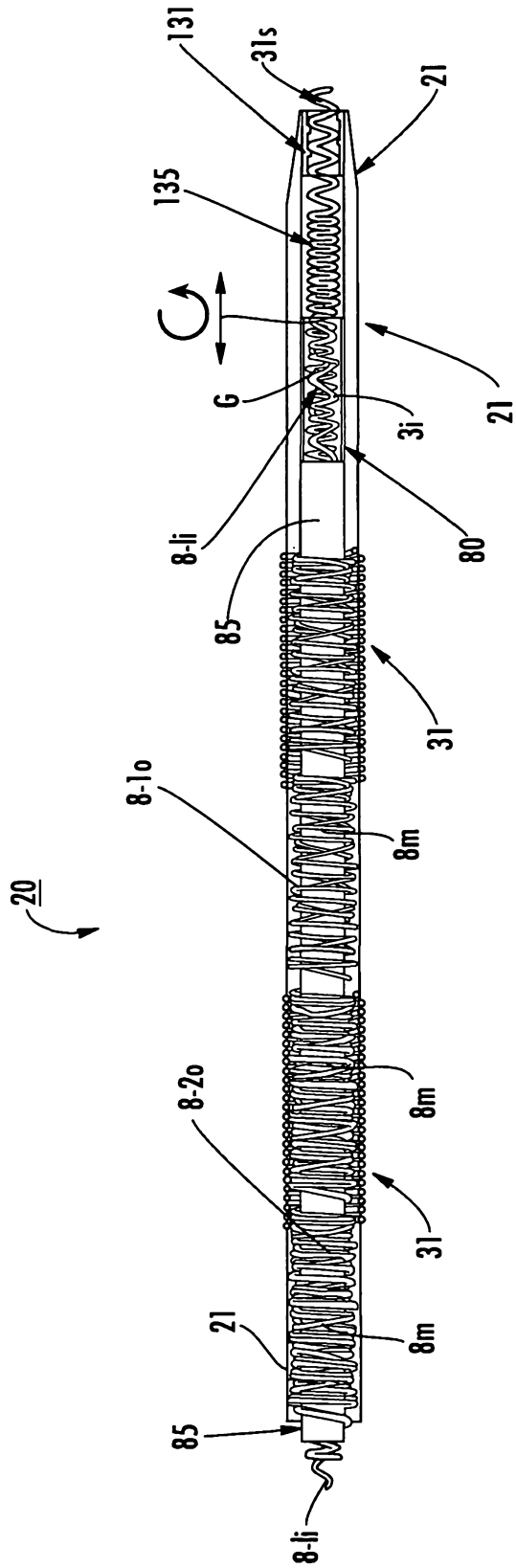

FIG. 58A

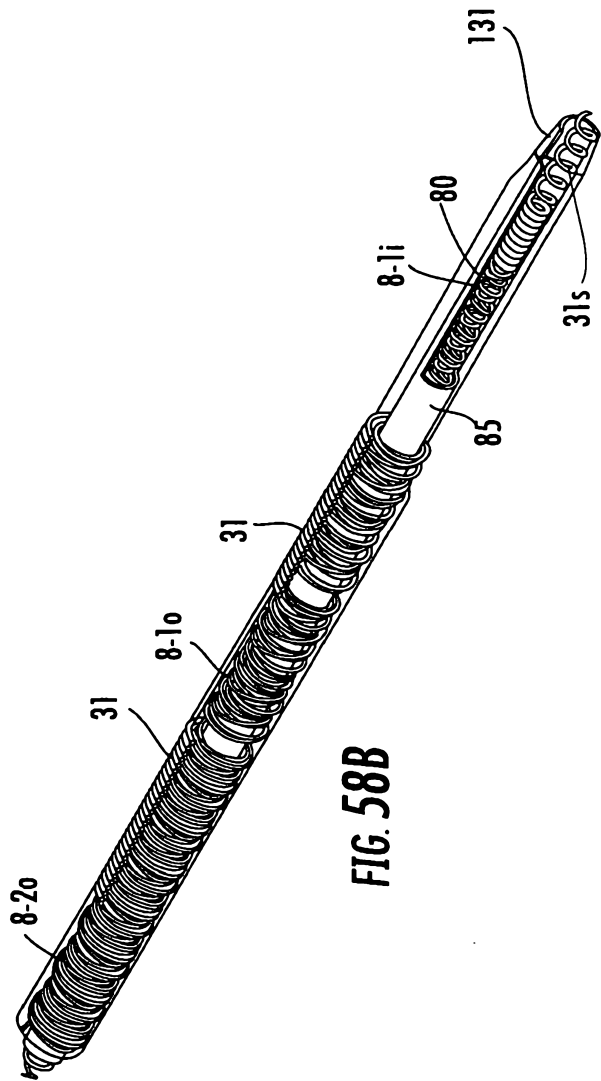

FIG. 58B