

(19)



(11)

**EP 2 478 819 B1**

(12)

**EUROPEAN PATENT SPECIFICATION**

(45) Date of publication and mention of the grant of the patent:  
**31.12.2014 Bulletin 2015/01**

(51) Int Cl.:  
**A47L 15/44<sup>(2006.01)</sup>**

(21) Application number: **12151540.7**

(22) Date of filing: **18.01.2012**

**(54) A washing agent dispensing device for a washing machine for household use, in particular a dishwasher, and washing machine thereof**

Waschmittelspendervorrichtung für eine Waschmaschine für Haushaltszwecke, insbesondere einen Geschirrspüler, und Waschmaschine dafür

Dispositif de distribution d'agent de nettoyage pour machine à laver pour utilisation domestique, en particulier un lave-vaisselle et machine à laver correspondante

(84) Designated Contracting States:  
**AL AT BE BG CH CY CZ DE DK EE ES FI FR GB GR HR HU IE IS IT LI LT LU LV MC MK MT NL NO PL PT RO RS SE SI SK SM TR**

(30) Priority: **24.01.2011 IT TO20110051**

(43) Date of publication of application:  
**25.07.2012 Bulletin 2012/30**

(73) Proprietor: **T & P - S.p.A.**  
**21040 Venegono Superiore (VA) (IT)**

(72) Inventors:  
• **Lavazza, Alberto**  
**21010 Cardano al Campo (VA) (IT)**

• **Rotta, Andrea**  
**22070 Appiano Gentile (CO) (IT)**

(74) Representative: **Dini, Roberto et al**  
**Metroconsult S.r.l.**  
**Via Sestriere 100**  
**10060 None (TO) (IT)**

(56) References cited:  
**EP-A1- 0 602 572 EP-A2- 0 719 517**  
**WO-A1-02/057627 DE-A1- 3 304 037**  
**US-A- 3 827 600 US-A- 5 603 431**  
**US-A1- 2004 118 434**

**EP 2 478 819 B1**

Note: Within nine months of the publication of the mention of the grant of the European patent in the European Patent Bulletin, any person may give notice to the European Patent Office of opposition to that patent, in accordance with the Implementing Regulations. Notice of opposition shall not be deemed to have been filed until the opposition fee has been paid. (Art. 99(1) European Patent Convention).

## Description

**[0001]** The present invention relates to a washing agent dispensing device for a washing machine for household use, in particular a dishwasher, according to the preamble of claim 1. A washing agent dispensing device of a similar type is disclosed, for example, in document US3,827,600.

**[0002]** The present invention also relates to a method of operation of the dispensing device and to a related washing machine for household use, in particular a dishwasher.

**[0003]** Washing machines known in the art comprise a control system for managing and controlling the operation of the washing machine, said control system being adapted to implement at least one wash program.

**[0004]** For example, washing machines, in particular dishwashers, currently available on the market are usually fitted with at least some of the following wash programs:

- a basic wash program, to be used for washing crockery with a normal degree of dirtiness at a certain drying stage. Such a program typically comprises an initial cold prewash step, a hot wash step, two cold rinse steps, a hot rinse step, and a final drying step;
- an intensive wash program, to be used for very dirty crockery, or when food residues are particularly hard to remove (e.g. very dry or burned). Such a program typically comprises an initial hot prewash step, a hot wash step, a first cold rinse step, a second cold rinse step, a third hot rinse step, and a final drying step;
- an economy wash program, to be used for washing crockery which is not very dirty or for partial loads. Such a program typically comprises an initial cold prewash step, a hot wash step, a first cold rinse step, a second hot rinse step, and a final drying step.

**[0005]** Consequently, known washing machines comprise a tub in which crockery is cleaned during a wash step of the above-mentioned wash program by a wash liquid, in particular water added with a detergent agent.

**[0006]** The wash program also includes at least one rinse step, wherein the crockery is subjected to the action of a rinse liquid, in particular water added with a rinse aid agent.

**[0007]** Therefore, known washing machines are fitted with suitable dispensing devices, which comprise distinct compartments or reservoirs adapted to contain different washing agents specific for said steps of a wash program; said washing agents typically consist of a (powder) detergent, which is dispensed during the wash step, and a liquid additive, such as rinse aid, which is dispensed during the rinse step, in particular during a hot rinse step. In those cases wherein the use of detergent is also recommended for the prewash step, the same detergent also used for the wash step is usually employed.

**[0008]** A known dispensing device generally consists

of a body usually housed in the inner panel of the front door of the dishwashing machine; said body comprises at least one compartment for the dose of detergent required by the wash step, said compartment being provided with a lid which is opened at the appropriate instant of the wash program by the machine's programming device.

**[0009]** In addition to said single-dose wash detergent compartment, the body of the dispensing device usually also includes a dispenser of liquid additive, such as a rinse aid agent, to be dispensed during the rinse step.

**[0010]** As regards the use of detergent also during the prewash step, some dispensing devices may be fitted with an additional compartment, distinct from the one containing the detergent intended for the wash step. In such cases, the lid that closes the wash detergent compartment usually extends to cover also said additional compartment.

**[0011]** However, washing machines, in particular dishwashers, known in the art suffer from many drawbacks.

**[0012]** In particular, a very important problem of prior-art solutions is that they do not ensure that the washing agents are released into the wash liquid reliably and constantly over time.

**[0013]** A further drawback of prior-art solutions is that they require that the quantity of washing agents, in particular of rinse aid agent, that must be dispensed during the rinse step be set beforehand (e.g. mechanically) by the user, without offering the latter the possibility of having said dispensing process handled electronically and dynamically by the washing machine itself according to the specific requirements of a certain wash program.

**[0014]** The prior art also includes the washing machine described in US patent application No. US2004118434.

**[0015]** Said washing machine comprises a washing agent dispensing device which includes:

- a first shape memory element (also known in the art as SMA, which stands for "Shape Memory Alloy", or SMW, which stands for "Shape Memory Wire"), which allows opening a first cover for releasing detergent contained in at least a first compartment of the dispensing device;
- a second shape memory element associated with a second cover, for releasing a liquid additive or rinse aid agent to be dispensed during the rinse step, said rinse aid agent being contained in a second compartment of the dispensing device.

**[0016]** The dispensing device described in US patent application No. US2004118434 has some drawbacks as well, in that its implementation implies higher production costs, in particular due to the necessary duplication of the shape memory elements and of the mechanisms employed for releasing the detergent and the rinse aid agent.

**[0017]** Moreover, the dispensing device described in US patent application No. US2004118434 does not allow for a controlled, metered and measured release of said

rinse aid agent contained in a second compartment of the dispensing device. In fact, upon actuation of the second shape memory element, the above-described dispensing device causes a second cover to open and releases the entire quantity of rinse aid agent previously poured by the user into the second compartment of the dispensing device; as a consequence, the dispensing device described in US patent application No. US2004118434 does not allow to obtain a release handled in an electronic, dynamic and measured manner by the washing machine itself.

**[0018]** In this frame, it is the main object of the present invention to provide a washing agent dispensing device for a washing machine for household use, in particular a dishwasher, and a related washing machine, which are so designed as to overcome the drawbacks of the prior art.

**[0019]** It is another object of the present invention to provide a washing agent dispensing device for a washing machine for household use, in particular a dishwasher, and a related washing machine, which can ensure that the washing agents are released into the wash liquid reliably and constantly over time.

**[0020]** It is a further object of the present invention to provide a washing agent dispensing device, and a related washing machine, wherein the delivery of the washing agents, in particular of the rinse aid agent, can be handled in an electronic, dynamic and measured manner by the washing machine itself.

**[0021]** It is yet another main object of the present invention to provide a washing agent dispensing device for a washing machine for household use, in particular a dishwasher, and a related washing machine, which are so designed as to require lower production costs while at the same time ensuring a controlled, metered and measured release of the washing agents contained in the dispensing device, in particular of the rinse aid agent contained in a second compartment of said dispensing device.

**[0022]** Said objects are achieved by the present invention through a washing agent dispensing device for a washing machine for household use, in particular a dishwasher, and a related washing machine, incorporating the features set out in the appended claims, which are intended as an integral part of the present description.

**[0023]** Further objects, features and advantages of the present invention will become apparent from the following detailed description and from the annexed drawings, which are supplied by way of non-limiting explanatory example, wherein:

- Fig. 1 is a schematic view of a washing machine for household use, in particular a dishwasher, which incorporates the features of the present invention;
- Fig. 2 is a perspective view of the dispensing device according to the present invention;
- Figs. 3a to 7a are plan views of the dispensing device according to the present invention in different oper-

ating conditions;

- Figs. 3b to 7b are sectional views of the dispensing device according to the present invention, respectively in the same operating conditions as those shown in Figs. 3a to 7a.

**[0024]** Referring now to the annexed drawings, in Fig. 1 reference numeral 1 designates as a whole a washing machine for household use, in particular a dishwasher, according to the present invention.

**[0025]** The washing machine 1 comprises an electric or electronic control system SC for handling and controlling the operation of the washing machine 1, said control system SC being adapted to implement at least one wash program.

**[0026]** The washing machine 1 further comprises a tub 2 in which crockery is cleaned through washing means comprising a wash liquid; in particular, said at least one wash program comprises a wash step, wherein the wash liquid consists of water added with a detergent agent, and a rinse step, wherein the wash liquid consists of water added with a rinse aid agent. Whenever the use of a detergent agent is also recommended for a prewash step, the same detergent can be used as the one employed for the wash step.

**[0027]** The annexed drawings do not show the crockery, the wash liquid, the detergent agent and the rinse aid agent.

**[0028]** Said wash liquid (water added with detergent agent and/or rinse aid agent) is sprayed onto the crockery to be washed by means of at least one sprayer 3a, 3b; in particular, Fig. 1 shows a first sprayer 3a associated with a lower rack 4a and a second sprayer 3b associated with an upper rack 4b, said racks 4a, 4b being adapted to receive the crockery to be washed and rinsed.

**[0029]** Preferably, the washing machine 1 comprises a circuit for distributing the wash liquid inside said washing machine 1; in particular, said distribution circuit may comprise at least one delivery duct 5 associated with a pump 6, which allow the wash liquid to flow from a pit 7 to said first sprayer 3a and second sprayer 3b.

**[0030]** The washing machine 1 also comprises a dispensing device 10 for dispensing washing agents during the various steps of at least one wash program; the perspective view of Fig. 2 shows in particular a rear portion of the dispensing device 10.

**[0031]** Preferably, said dispensing device 10 is housed in the inner panel 9 of a front door 8 for loading the dishwasher 1, and said rear portion is that portion of the dispensing device 10 which is inserted into said inner panel 9.

**[0032]** Figs. 3a to 7a show rear views of the dispensing device 10 of the present invention in different operating conditions, whereas Figs. 3b to 7b are sectional views of the dispensing device 10 corresponding to the operating conditions illustrated in Figs. 2a to 6a.

**[0033]** Figs. 2 to 7b show that, in accordance with the present invention, the dispensing device 10 comprises:

- at least one compartment 11 associated with a lid 12 for sealing a detergent agent into said at least one compartment 11. For example, said detergent agent is dispensed during a wash step of a wash program, and may consist of powder or tablet detergent.

**[0034]** Said at least one compartment 11 can be designed in a manner such as to comprise a first compartment (not shown in the drawings) for containing a detergent agent for a wash step, and a second compartment (not shown in the drawings) for containing a detergent agent for a prewash step.

**[0035]** Preferably, the lid 12 rotates about an axis, designated X in Fig. 2, for causing said compartment 11 to open in order to release the detergent agent during a wash step; said lid 12 (which in Figs. 5b and 6b is shown in the wide open position) is preferably adapted to close the compartment 11 against the action of a spring (not shown) reacting between the dispensing device 10 and the lid 12 itself. It is apparent that the lid 12 according to the present invention may be so designed as to include a sliding or translating opening system, instead of being rotatable about said axis X.

**[0036]** The dispensing device 10 comprises a locking mechanism 13 for holding the lid 12 in the closed position; said locking mechanism preferably comprises an arm 13 adapted to rotate about a pin P, which arm is fitted with a tooth 13D adapted to engage with a serration 12D of the lid 12.

**[0037]** The tooth 13D of the arm 13 and the serration 12D of the lid 12 are visible in Figs. 3b, 4b and 7b; it should also be noted that the arm 13 has been drawn with a dashed line in Figs. 3a to 7a, in that said arm 13 is associated with a front portion of the dispensing device 10 and is not therefore directly visible in the rear views of the dispensing device 10 shown in Figs. 3a to 7a.

**[0038]** Preferably, the arm 13 is provided with an appendix 13A that protrudes from a slot 10F of the dispensing device 10, so as to allow the arm 13 to be manually operated by a user in order to open the lid 12 manually.

**[0039]** In addition, the dispensing device 10 comprises a container 20 for a rinse aid agent, in particular said container 20 being associated with release means 21 which allow the rinse aid agent to be dispensed during a rinse step,

**[0040]** In particular, said release means comprise a rod 21 associated with a small pump (not shown in the drawings) for pumping a predetermined quantity of rinse aid agent at each activation of the release means. It is clear that, in accordance with the present invention, the rod 21 can be associated with a valve (also not shown in the annexed drawings) instead of said small pump.

**[0041]** Preferably, the vertical movement of the rod 21 is limited by a pair of supports 14 (well visible in Fig. 2) associated with the dispensing device 10.

**[0042]** The dispensing device 10 further comprises activating means 30, 31 for activating said locking mechanism

13 in order to open the lid 12.

**[0043]** In accordance with the present invention, said activating means comprise a movable member 30 rotatably mounted about a pin P and an actuating element 31 secured through a first end 31A to the dispensing device 10 and through a second end 31B to the movable member 30, said actuating element 31 being adapted to drive the movable member 30:

- in a first rotation direction S1 (see dashed arrow S1 in Figs. 3a and 4a) about said pin P, in order to activate said locking mechanism 13 and open the lid 12;
- in a second rotation direction S2 (see dashed arrow S2 in Figs. 5a, 6a and 7a) about said pin P, in order to activate said release means 21 and dispense the rinse aid agent contained in the container 20,

said dispensing device 10 comprising elastic means 40 associated with said movable member 30, so as to allow switching from said first rotation direction S1 to said second rotation direction S2.

**[0044]** Preferably, the actuating element 31 consists of a single shape memory element, in particular of the monostable type, and the dispensing device 10 comprises power supply means including an electric circuit (not shown in the drawings) connected to the first end 31A and/or to the second end 31B of the shape memory element 31.

**[0045]** As known, in monostable shape memory elements the activation of the actuator through an electric circuit always causes the actuator to move from a first original condition to a second operating condition; when no longer activated, the actuator always returns into the first original condition.

**[0046]** In the case of the actuating element 31 according to the present invention, it can be in a first operating condition (shown in Figs. 3a, 5a and 7a), wherein it is not activated and has a certain first length L1; upon activation of the electric circuit connected to the first end 31A and/or to the second end 31B, the actuating element 31 can switch to a second operating condition (shown in Figs. 4a and 6a), wherein it is activated and has a certain second length L2, shorter than said first length L1. In Figs. 3a to 7a, said first length L1 and second length L2 are represented by a dash-dot-dot line.

**[0047]** As a consequence, the shape memory actuating element 31 according to the present invention can become shorter following the activation of the electric circuit connected to the first end 31A and/or to the second end 31B.

**[0048]** In a preferred embodiment, said first end 31A and second end 31B of the actuating element 31 are positioned on substantially opposite sides relative to said pin P.

**[0049]** As previously stated, the first end 31A of the actuating element 31 is associated with the dispensing device 10; it is however clear that the first end 31A of the actuating element 31 may also be directly associated with

the washing machine 1.

**[0050]** As can be seen in the annexed drawings, the arm 13 and the movable member 30 are associated with each other through the pin P, which is common to both such components; it is however clear that the arm 13 and the movable member 30 may alternatively be associated with each other in a different manner.

**[0051]** In a preferred embodiment, the movable member 30 comprises a branch 30D, the movable member 30 and said branch 30D being so designed as to form a substantially L-shaped body. Said branch 30D of the movable member 30 is adapted to abut on said release means 21, in particular on the rod 21 associated with a small pump, in order to dispense the rinse aid agent contained in the container 20.

**[0052]** Preferably, said elastic means comprise a tongue 40 with a first portion 41A secured to the dispensing device 10 and a second portion 41B adapted to abut on the movable member 30, in particular on said branch 30D of the movable member 30.

**[0053]** As shown in particular in Figs. 5a, 6a and 7a, the second portion 41B of the tongue 40 abuts on the branch 30D on a side opposite to the release means 21.

**[0054]** In an advantageous embodiment, said first portion 41A is secured to the rear part of said dispensing device 10, in particular in the area corresponding to the compartment 11; said dispensing device 10 also includes retainers 15 for limiting the movements of the tongue 40.

**[0055]** Furthermore, said rod 21 comprises:

- an abutment surface 21A adapted to receive the thrust from the movable member 30, in particular from the branch 30D of said movable member 30;
- a protuberance 21P, which, in association with said pair of supports 14, limits the thrust towards the movable member 30 exerted by the small pump on the rod 21 itself.

**[0056]** In Figs. 3a to 7b, it can be observed that, when the pin P and said first end 31A and second end 31B of the actuating element 31 are aligned, the movable member 30 is substantially at a so-called "dead centre".

**[0057]** When the lid 12 is closed, the tooth 13D of the arm 13 is engaged with the serration 12D of the lid 12; the movable member 20, which is associated with the arm 13 through the pin P, is in an operating condition wherein said first end 31A and second end 31B of the actuating element 31 are aligned under the pin P (see Figs. 3a and 3b).

**[0058]** When the actuating element 31 is activated, it moves the movable member 30 in a first rotation direction S1 (see Fig. 4a) and causes the activation of the locking mechanism or arm 13; as a result, the rotation of the movable member 30 in said first rotation direction S1 allows the tooth 13D of the arm 13 to be disengaged from the serration 12D of the lid 12 (see Fig. 4b), thus opening the lid 12 (visible in Fig. 5b).

**[0059]** Since the constraint provided by the engage-

ment between the tooth 13D of the arm 13 and the serration 12D of the lid 12 is no longer present, the movable member 30 undergoes the thrust exerted by the elastic means 40 and rotates in a second direction S2, thus overcoming the so-called "dead centre" and getting in a situation wherein said first end 31A and second end 31B of the actuating element 31 are aligned above the pin P (see Fig. 5a).

**[0060]** The activation of the actuating element 31 causes further movement of the movable member 30 in a second rotation direction S2, which in turn moves and activates said release means 21 to release the rinse aid agent contained in the container 20.

**[0061]** In particular, the repeated activation of the actuating element 31 allows to obtain successive actuations of said release means 21, in particular of the small pump associated with the rod 21, by the branch 30D of the movable member 30; said successive actuations allow to obtain a measured and metered release of the rinse aid agent contained in the container 20, said release being correlated to the number of activations of the actuating element 31.

**[0062]** When the wash program of the washing machine 1 has been completed, the user can close the lid 12 again in order to bring the dispensing device 10 back into the initial condition shown in Fig. 3a, i.e. with the tooth 13D of the arm 13 engaged with the serration 12D of the lid 12, and with the movable member 20 (associated with the arm 13 through the pin P) in an operating condition wherein said first end 31A and second end 31B of the actuating element 31 are aligned under the pin P.

**[0063]** It must be pointed out that the dispensing device 10 is shown in Figs. 7a and 7b in a condition that precedes the closing of the lid 12 by the user; in fact, the serration 12D of the lid 12 is near the tooth 13D of the arm 13.

**[0064]** The method of operation of the dispensing device 10 according to the present invention is apparent from the above description, said dispensing device 10 comprising:

- at least one compartment 11 associated with a lid 12 for sealing a detergent agent into said at least one compartment 11.
- a locking mechanism 13 for holding the lid 12 in the closed position;
- activating means 30, 31 for activating said locking mechanism 13 in order to open the lid 12;
- a container 20 for containing a rinse aid agent, in particular said container 20 being associated with release means 21 which allow the rinse aid agent to be dispensed during a rinse step.

**[0065]** In accordance with the present invention, said method of operation comprises the steps of:

- a) activating an actuating element 31 comprised in said activating means 30, 31, the actuating element 31 being secured through a first end 31A to the dis-

pensing device 10 and through a second end 31B to a movable member 30, the activation of the actuating element 31 being such that the movable member 30 is driven in a first rotation direction S1 about a pin P so as to activate said locking mechanism 13 and open the lid 12 (Fig. 4a);

b) deactivating the actuating element 31 so that elastic means 40 associated with said movable member 30 allow the movable member 30 to switch from said first rotation direction S1 to a second rotation direction S2 about the pin P (Fig. 5a);

c) activating the actuating element 31 so as to rotate the movable member 30 in said second rotation direction S2 about the pin P in order to activate said release means 21 and dispense the rinse aid agent contained in the container 20 (Fig. 6a).

**[0066]** Preferably, said actuating element 31 consists of a single shape memory element and said steps a) and c) of activating the actuating element 31 are carried out by activating power supply means comprising an electric circuit (not shown in the drawings) connected to the first end 31A and/or to the second end 31B of the actuating element 31 or single shape memory element.

**[0067]** In a preferred embodiment, said step c) is carried out by repeatedly activating the actuating element 31, so that the release means 21, in particular a small pump associated with a rod 21, is actuated multiple times in succession by the movable member 30; this allows to obtain a measured and metered release of the rinse aid agent contained in the container 20, suited to the type of wash program being executed.

**[0068]** Preferably, said repeated activation of the actuating element 31 is obtained by repeatedly activating the electric circuit connected to the first end 31A and/or to the second end 31B of the shape memory element 31.

**[0069]** The features of the present invention, as well as the advantages thereof, are apparent from the above description.

**[0070]** In particular, the washing agent dispensing device for a washing machine for household use, in particular a dishwasher, the method of operation of said dispensing device and the related washing machine ensure that the washing agents are released into the wash liquid reliably and constantly over time.

**[0071]** They also allow the washing machine itself to handle the delivery of a predetermined quantity of washing agents, in particular of a rinse aid agent, in an electronic and dynamic manner, without the user having to set said delivery beforehand (e.g. mechanically).

**[0072]** As a matter of fact, the repeated activation of the actuating element 31 allows to obtain successive activations of the release means 21, in particular of a small pump associated with a rod 21, by the movable member 30. This in turn allows to obtain a metered release of the rinse aid agent contained in the container 20 as suited to the type of wash program being executed.

**[0073]** A further advantage of the dispensing device,

of the method of operation thereof and of the washing machine for household use according to the present invention is that the implementation of a single actuating element 31, in particular a single shape memory element, for releasing both the detergent agent and the rinse aid agent lowers the production costs of the dispensing device 1 and hence of the washing machine; in addition, such a solution turns out to be particularly flexible and comfortable.

**[0074]** The dispensing device, the method of operation and the washing machine described herein by way of example may be subject to many possible variations without departing from the novelty spirit of the inventive idea; it is also clear that in the practical implementation of the invention the illustrated details may have different shapes or be replaced with other technically equivalent elements.

**[0075]** It can therefore be easily understood that the present invention is not limited to the above-described dispensing device, method and washing machine, but may be subject to many modifications, improvements or replacements of equivalent parts and elements without departing from the inventive idea, as clearly specified in the following claims.

## Claims

1. A washing agent dispensing device (10) for a washing machine (1) for household use, in particular a dishwasher, said dispensing device (10) comprising:

- at least one compartment (11) associated with a lid (12) for sealing a detergent agent into said at least one compartment (11);

- a locking mechanism (13) for holding the lid (12) in the closed position;

- activating means (30, 31) for activating said locking mechanism (13) in order to open the lid (12) and dispense the detergent;

- a container (20) for containing a rinse aid agent, in particular said container (20) being associated with release means (21) which allow the rinse aid agent to be dispensed during a rinse step, wherein said activating means comprise a movable member (30) rotatably mounted about a pin (P) and an actuating element (31) secured through a first end (31A) to the dispensing device (10) and through a second end (31B) to the movable member (30), said actuating element (31) being adapted to drive the movable member (30) in a first rotation direction (S1) about said pin (P) in order to activate said locking mechanism (13) and open the lid (12),

### characterized in that

said actuating element (31) is adapted to drive the movable member (30) in a second rotation direction (S2) about said pin (P) in order to activate said release means (21) and dispense the

- rinse aid agent contained in the container (20), said dispensing device (10) comprising elastic means (40) associated with said movable member (30) so as to allow switching from said first rotation direction (S1) to said second rotation direction (S2).
2. A dispensing device (10) according to claim 1, **characterized in that** said actuating element (31) consists of a single shape memory element, in particular of the monostable type, and the dispensing device (10) comprises power supply means including an electric circuit connected to the first end (31A) and/or to the second end (31B) of the shape memory element (31).
  3. A dispensing device (10) according to claim 2, **characterized in that** said actuating element (31) may be either in a first operating condition, wherein it is not activated and has a certain first length (L1), or in a second operating condition, wherein it is activated and has a certain second length (L2), shorter than said first length (L1).
  4. A dispensing device (10) according to one or more of the preceding claims, **characterized in that** said first (31A) and second (31B) ends of the actuating element (31) are positioned on substantially opposite sides relative to said pin (P).
  5. A dispensing device (10) according to claim 1, **characterized in that** said locking mechanism comprises an arm (13) adapted to rotate about said pin (P), said arm (13) being fitted with a tooth (13D) adapted to engage with a serration (12D) of the lid (12).
  6. A dispensing device (10) according to claim 5, **characterized in that** the arm (13) and the movable member (30) are associated with each other by means of said pin (P).
  7. A dispensing device (10) according to one or more of the preceding claims, **characterized in that** said movable member (30) comprises a branch (30D).
  8. A dispensing device (10) according to claim 7, **characterized in that** the movable member (30) and said branch (30D) are so designed as to form a substantially L-shaped body.
  9. A dispensing device (10) according to one or more of claims 7 and 8, **characterized in that** said branch (30D) of the movable member (30) is adapted to abut on said release means (21), in particular on a rod (21) associated with a small pump or a valve, in order to dispense the rinse aid agent contained in the container (20).
  10. A dispensing device (10) according to one or more of claims 1 and 7 to 9, **characterized in that** said elastic means comprise a tongue (40) with a first portion (41A) secured to the dispensing device (10) and a second portion (41B) adapted to abut on the movable member (30), in particular on said branch (30D) of the movable member (30).
  11. A dispensing device (10) according to claim 10, **characterized in that** said second portion (41B) of the tongue (40) abuts on the branch (30D) on a side opposite to the release means (21).
  12. A method of operation of a washing agent dispensing device (10) for a washing machine (1) for household use, in particular a dishwasher, said dispensing device (10) comprising:
    - at least one compartment (11) associated with a lid (12) for sealing a detergent agent into said at least one compartment (11);
    - a locking mechanism (13) for holding the lid (12) in the closed position;
    - activating means (30, 31) for activating said locking mechanism (13) in order to open the lid (12);
    - a container (20) for containing a rinse aid agent, in particular said container (20) being associated with release means (21) which allow the rinse aid agent to be dispensed during a rinse step, said method comprising the step of:
      - a) activating an actuating element (31) comprised in said activating means (30, 31), the actuating element (31) being secured through a first end (31A) to the dispensing device (10) and through a second end (31B) to a movable member (30), the activation of the actuating element (31) being such that the movable member (30) is driven in a first rotation direction (S1) about a pin (P) so as to activate said locking mechanism (13) and open the lid (12);
      - said method being **characterized in that** it comprises the following steps:
        - b) deactivating the actuating element (31) so that elastic means (40) associated with said movable member (30) allow the movable member (30) to switch from said first rotation direction (S1) to a second rotation direction (S2) about the pin (P);
        - c) activating the actuating element (31) so as to rotate the movable member (30) in said second rotation direction (S2) about the pin (P) in order to activate said release means (21) and dispense the rinse aid agent contained in the container (20).

13. A method according to claim 12, **characterized in that** said actuating element (31) consists of a single shape memory element, and said steps a) and c) of activating the actuating element (31) are carried out by activating power supply means comprising an electric circuit connected to the first end (31A) and/or to the second end (31B) of the actuating element (31).
14. A method according to one or more of claims 12 and 13, **characterized in that** said step c) is carried out by repeatedly activating the actuating element (31), so that the release means (21), in particular a small pump associated with a rod (21), are actuated multiple times in succession by the movable member (30).
15. A washing machine (1) for household use, in particular a dishwasher, comprising a dispensing device (10) and/or implementing a method of operation of a dispensing device (10) according to one or more of the preceding claims 1 to 14.

#### Patentansprüche

1. Waschmittelspendergerät (10) für eine Waschmaschine (1) zur Nutzung im Haushalt, insbesondere für einen Geschirrspüler, wobei das Spendergerät (10) umfasst:
- zumindest eine Kammer (11), die mit einem Deckel (12) zum Versiegeln eines Reinigungsmittels in der zumindest einen Kammer (11) verbunden ist;
  - einen Verschließmechanismus (13) zum Halten des Deckels (12) in der geschlossenen Position;
  - Aktivierungsmittel (30, 31) zum Aktivieren des Verschließmechanismus (13), um den Deckel (12) zu öffnen und das Reinigungsmittel abzugeben;
  - einen Behälter (20) zum Enthalten eines Klarspülmittels, wobei der Behälter (20) insbesondere mit Freigabemitteln (21) verbunden ist, die es ermöglichen, dass das Klarspülmittel während eines Spülschritts gespendet wird, wobei die Aktivierungsmittel ein bewegbares Element (30), das um einen Bolzen (P) herum rotierbar angebracht ist, und ein Antriebselement (31), das durch ein erstes Ende (31A) an dem Spendergerät (10) und durch ein zweites Ende (31 B) an dem bewegbaren Element (30) befestigt ist, umfassen, wobei das Antriebselement (31) angepasst ist, das bewegbare Element (30) in einer ersten Drehrichtung (S1) um den Bolzen (P) herum zu treiben, um den Verschließmechanismus (13) zu aktivieren und den

Deckel (12) zu öffnen, **dadurch gekennzeichnet, dass** das Antriebselement (31) angepasst ist, das bewegbare Element (30) in einer zweiten Drehrichtung (S2) um den Bolzen (P) herum zu treiben, um die Freigabemittel (21) zu aktivieren und das Klarspülmittel, das in dem Behälter (20) enthalten ist, zu spenden, wobei das Spendergerät (10) elastische Mittel (40) umfasst, die mit dem bewegbaren Element (30) verbunden sind, um ein Umschalten von der ersten Drehrichtung (S1) zu der zweiten Drehrichtung (S2) zu ermöglichen.

2. Spendergerät (10) nach Anspruch 1, **dadurch gekennzeichnet, dass** das Antriebselement (31) aus einem einzelnen Formgedächtniselement besteht, insbesondere vom monostabilen Typ, und das Spendergerät (10) Energieversorgungsmittel umfasst, die eine elektrische Schaltung beinhalten, die mit dem ersten Ende (31A) und/oder dem zweiten Ende (31 B) des Formgedächtniselements (31) verbunden ist.
3. Spendergerät (10) nach Anspruch 2, **dadurch gekennzeichnet, dass** das Antriebselement (31) entweder in einem ersten Betriebszustand sein kann, in dem es nicht aktiviert ist und eine bestimmte erste Länge (L1) aufweist, oder in einem zweiten Betriebszustand, in dem es aktiviert ist und eine bestimmte zweite Länge (L2) aufweist, die kürzer ist als die erste Länge (L1).
4. Spendergerät (10) nach einem oder mehreren der vorangegangenen Ansprüche, **dadurch gekennzeichnet, dass** das erste (31A) und zweite (31 B) Ende des Antriebselements (31) an im Wesentlichen gegenüberliegenden Seiten in Bezug auf den Bolzen (P) positioniert sind.
5. Spendergerät (10) nach Anspruch 1, **dadurch gekennzeichnet, dass** der Verschließmechanismus einen Arm (13) umfasst, der angepasst ist, sich um den Bolzen (P) herum zu drehen, wobei der Arm (13) mit einem Zahn (13D) versehen ist, der angepasst ist, in eine Kerbung (12D) des Deckels (12) einzugreifen.
6. Spendergerät (10) nach Anspruch 5, **dadurch gekennzeichnet, dass** der Arm (13) und das bewegbare Element (30) miteinander mittels des Bolzens (P) verbunden sind.
7. Spendergerät (10) nach einem oder mehreren der vorangegangenen Ansprüche, **dadurch gekennzeichnet, dass** das bewegbare Element (30) einen Zweig (30D) umfasst.

8. Spendergerät (10) nach Anspruch 7, **dadurch gekennzeichnet, dass** das bewegbare Element (30) und der Zweig (30D) so gestaltet sind, dass sie einen im Wesentlichen L-förmigen Körper formen.
9. Spendergerät (10) nach einem oder mehreren der Ansprüche 7 und 8, **dadurch gekennzeichnet, dass** der Zweig (30D) des bewegbaren Elements (30) angepasst ist, an den Freigabemitteln (21) anzuliegen, insbesondere an einem Zapfen (21), der mit einer kleinen Pumpe oder einem Ventil verbunden ist, um das Klarspülmittel, das in dem Behälter (20) enthalten ist, zu spenden.
10. Spendergerät (10) nach einem oder mehreren der Ansprüche 1 und 7 bis 9, **dadurch gekennzeichnet, dass** die elastischen Mittel eine Zunge (40) mit einem ersten Abschnitt (41A), der an dem Spendergerät (10) befestigt ist, und einem zweiten Abschnitt (41 B), der angepasst ist, an dem bewegbaren Element (30), insbesondere an dem Zweig (30D) des bewegbaren Elements (30), anzuliegen, umfassen.
11. Spendergerät (10) nach Anspruch 10, **dadurch gekennzeichnet, dass** der zweite Abschnitt (41 B) der Zunge (40) an dem Zweig (30D) an einer Seite gegenüber den Freigabemitteln (21) anliegt.
12. Verfahren zum Betreiben eines Waschmittelspendergeräts (10) für eine Waschmaschine (1) zur Nutzung im Haushalt, insbesondere für einen Geschirrspüler, wobei das Spendergerät (10) umfasst:
- zumindest eine Kammer (11), die mit einem Deckel (12) zum Versiegeln eines Reinigungsmittels in der zumindest einen Kammer (11) verbunden ist;
  - einen Verschließmechanismus (13) zum Halten des Deckels (12) in der geschlossenen Position;
  - Aktivierungsmittel (30, 31) zum Aktivieren des Verschließmechanismus (13), um den Deckel (12) zu öffnen;
  - einen Behälter (20) zum Enthalten eines Klarspülmittels, wobei der Behälter (20) insbesondere mit Freigabemitteln (21) verbunden ist, die es ermöglichen, dass das Klarspülmittel während eines Spülschritts gespendet wird, wobei das Verfahren den Schritt umfasst:
- a) Aktivieren eines Antriebselements (31), das von den Aktivierungsmitteln (30, 31) umfasst ist, wobei das Antriebselement (31) durch ein erstes Ende (31A) an dem Spendergerät (10) und durch ein zweites Ende (31 B) an einem bewegbaren Element (30) befestigt ist, wobei die Aktivierung des Antriebselements (31) so ist, dass das bewegbare Element (30) in einer ersten Drehrichtung (S1) um einen Bolzen (P) herum getrieben wird, um den Verschließmechanismus (13) zu aktivieren und den Deckel (12) zu öffnen; wobei das Verfahren **dadurch gekennzeichnet ist, dass** es die folgenden Schritte umfasst:
    - b) Deaktivieren des Antriebselements (31), sodass elastische Mittel (40), die mit dem bewegbaren Element (30) verbunden sind, es ermöglichen, dass das bewegbare Element (30) von der ersten Drehrichtung (S1) zu einer zweiten Drehrichtung (S2) um den Bolzen (P) herum umschaltet;
    - c) Aktivieren des Antriebselements (31), sodass das bewegbare Element (30) in der zweiten Drehrichtung (S2) um den Bolzen (P) herum gedreht wird, um die Freigabemittel (21) zu aktivieren und das Klarspülmittel, das in dem Behälter (20) enthalten ist, zu spenden.
13. Verfahren nach Anspruch 12, **dadurch gekennzeichnet, dass** das Antriebselement (31) aus einem einzelnen Formgedächtniselement besteht, und die Schritte a) und c) des Aktivierens des Antriebselements (31) durch ein Aktivieren von Energieversorgungsmitteln, die eine elektrische Schaltung umfassen, die mit dem ersten Ende (31A) und/oder dem zweiten Ende (31 B) des Antriebselements (31) verbunden ist, durchgeführt werden.
14. Verfahren nach einem oder mehreren der Ansprüche 12 und 13, **dadurch gekennzeichnet, dass** der Schritt c) durch ein wiederholtes Aktivieren des Antriebselements (31) durchgeführt wird, sodass die Freigabemittel (21), insbesondere eine kleine Pumpe, die mit einem Zapfen (21) verbunden ist, mehrere Male in Folge durch das bewegbare Element (30) angetrieben werden.
15. Waschmaschine (1) zur Nutzung im Haushalt, insbesondere ein Geschirrspüler, umfassend ein Spendergerät (10) und/oder implementierend ein Verfahren zum Betreiben eines Spendergeräts (10) nach einem oder mehreren der vorangegangenen Ansprüche 1 bis 14.

## Revendications

1. Dispositif de distribution d'agent de lavage (10) destiné à une machine à laver (1) à usage domestique, notamment un lave-vaisselle, ledit dispositif de distribution (10) comprenant :

- au moins un compartiment (11) associé à un

- couvercle (12) destiné à enfermer hermétiquement un agent détergent dans ledit au moins un compartiment (11) ;
- un mécanisme de verrouillage (13) destiné à maintenir le couvercle (12) dans la position fermée ;
  - des moyens d'activation (30, 31) destinés à activer ledit mécanisme de verrouillage (13) afin d'ouvrir le couvercle (12) et distribuer le détergent ;
  - un conteneur (20) destiné à contenir un agent de rinçage, notamment ledit conteneur (20) étant associé à des moyens de libération (21) qui permettent de délivrer l'agent de rinçage pendant une étape de rinçage, lesdits moyens d'activation comprenant un élément mobile (30) monté à rotation sur un axe (P) et un élément d'actionnement (31) fixé par une première extrémité (31A) au dispositif de distribution (10) et par une seconde extrémité (31B) à l'élément mobile (30), ledit élément d'actionnement (31) étant adapté pour entraîner l'élément mobile (30) dans un premier sens de rotation (S1) sur ledit axe (P) afin d'activer ledit mécanisme de verrouillage (13) et d'ouvrir le couvercle (12),
- caractérisé en ce que**
- ledit élément d'actionnement (31) est adapté pour entraîner l'élément mobile (30) dans un second sens de rotation (S2) sur ledit axe (P) afin d'activer lesdits moyens de libération (21) et de distribuer l'agent de rinçage contenu dans le conteneur (20), ledit dispositif de distribution (10) comprenant des moyens élastiques (40) associés audit élément mobile (30) de manière à permettre la commutation dudit premier sens de rotation (S1) dans ledit second sens de rotation (S2).
2. Dispositif de distribution (10) selon la revendication 1, **caractérisé en ce que** ledit élément d'actionnement (31) consiste en un élément à mémoire de forme unique, notamment du type monostable, et le dispositif de distribution (10) comprend des moyens d'alimentation incluant un circuit électrique relié à la première extrémité (31A) et/ou à la seconde extrémité (31B) de l'élément à mémoire de forme (31).
  3. Dispositif de distribution (10) selon la revendication 2, **caractérisé en ce que** ledit élément d'actionnement (31) peut être soit dans un premier état de fonctionnement, dans lequel il n'est pas activé et a une certaine première longueur (L1), soit dans un second état de fonctionnement dans lequel il est activé et a une certaine seconde longueur (L2), plus courte que ladite première longueur (L1).
  4. Dispositif de distribution (10) selon l'une ou plusieurs des revendications précédentes, **caractérisé en ce que** lesdites première (31A) et seconde (31B) extrémités de l'élément d'actionnement (31) sont positionnées sur des côtés sensiblement opposés par rapport audit axe (P).
  5. Dispositif de distribution (10) selon la revendication 1, **caractérisé en ce que** ledit mécanisme de verrouillage comprend un bras (13) adapté pour tourner sur ledit axe (P), ledit bras (13) étant muni d'une dent (13D) adaptée pour venir en prise avec une denture (12D) du couvercle (12).
  6. Dispositif de distribution (10) selon la revendication 5, **caractérisé en ce que** le bras (13) et l'élément mobile (30) sont associés l'un à l'autre au moyen dudit axe (P).
  7. Dispositif de distribution (10) selon l'une ou plusieurs des revendications précédentes, **caractérisé en ce que** ledit élément mobile (30) comporte une branche (30D).
  8. Dispositif de distribution (10) selon la revendication 7, **caractérisé en ce que** l'élément mobile (30) et ladite branche (30D) sont conçues de manière à former un corps sensiblement en forme de L.
  9. Dispositif de distribution (10) selon l'une ou plusieurs des revendications 7 et 8, **caractérisé en ce que** ladite branche (30D) de l'élément mobile (30) est adaptée pour prendre appui sur lesdits moyens de libération (21), notamment sur une tige (21) associée à une petite pompe ou une valve, afin de distribuer l'agent de rinçage contenu dans le conteneur (20).
  10. Dispositif de distribution (10) selon l'une ou plusieurs des revendications 1 et 7 à 9, **caractérisé en ce que** lesdits moyens élastiques comprennent une languette (40) comportant une première portion (41A) fixée au dispositif de distribution (10) et une seconde portion (41B) adaptée pour prendre appui sur l'élément mobile (30), notamment sur ladite branche (30D) de l'élément mobile (30).
  11. Dispositif de distribution (10) selon la revendication 10, **caractérisé en ce que** ladite seconde portion (41B) de la languette (40) prend appui sur la branche (30D) sur un côté opposé aux moyens de libération (21).
  12. Procédé de fonctionnement d'un dispositif de distribution d'agent de lavage (10) destiné à une machine à laver (1) à usage domestique, notamment un lave-vaisselle, ledit dispositif de distribution (10) comprenant :
    - au moins un compartiment (11) associé à un

couvercle (12) destiné à enfermer hermétiquement un agent détergent dans ledit au moins un compartiment (11) ;

- un mécanisme de verrouillage (13) destiné à maintenir le couvercle (12) dans la position fermée ;

- des moyens d'activation (30, 31) destinés à activer ledit mécanisme de verrouillage (13) afin d'ouvrir le couvercle (12) ;

- un conteneur (20) destiné à contenir un agent de rinçage, notamment ledit conteneur (20) étant associé à des moyens de libération (21) qui permettent de délivrer l'agent de rinçage pendant une étape de rinçage,

ledit procédé comprenant l'étape consistant à :

a) activer l'élément d'actionnement (31) compris dans lesdits moyens d'activation (30, 31), l'élément d'actionnement (31) étant fixé par une première extrémité (31A) au dispositif de distribution (10) et par une seconde extrémité (31B) à un élément mobile (30), l'activation de l'élément d'actionnement (31) étant telle que l'élément mobile (30) est entraîné dans un premier sens de rotation (S1) sur un axe (P) de manière à activer ledit mécanisme de verrouillage (13) et à ouvrir le couvercle (12) ;

ledit procédé étant caractérisé en qu'il comprend les étapes suivantes consistant à :

b) désactiver l'élément d'actionnement (31) de sorte que les moyens élastiques (40) associés audit élément mobile (30) permettent à l'élément mobile (30) de commuter du premier sens de rotation (S1) dans un second sens de rotation (S2) sur l'axe (P) ;

c) activer l'élément d'actionnement (31) de manière à faire tourner l'élément mobile (30) dans ledit second sens de rotation (S2) sur l'axe (P) afin d'activer lesdits moyens de libération (21) et de distribuer l'agent de rinçage contenu dans le conteneur (20).

**13.** Procédé selon la revendication 12, **caractérisé en ce que** ledit élément d'actionnement (31) consiste en un élément à mémoire de forme unique, et lesdites étapes a) et c) d'activation de l'élément d'actionnement (31) sont réalisées par l'activation de moyens d'alimentation comprenant un circuit électrique relié à la première extrémité (31A) et/ou à la seconde extrémité (31B) de l'élément d'activation (31).

**14.** Procédé selon l'une ou plusieurs des revendications 12 et 13, **caractérisé en ce que** l'étape c) est réalisée par l'activation répétée de l'élément d'actionnement (31), de sorte que les moyens de libération (21), notamment une petite pompe associée à une

tige (21), sont actionnés plusieurs fois de suite par l'élément mobile (30).

**15.** Machine à laver (1) à usage domestique, notamment lave-vaisselle, comprenant un dispositif de distribution (10) et/ou mettant en oeuvre un procédé de fonctionnement d'un dispositif de distribution (10) selon l'une ou plusieurs des revendications précédente 1 à 14.

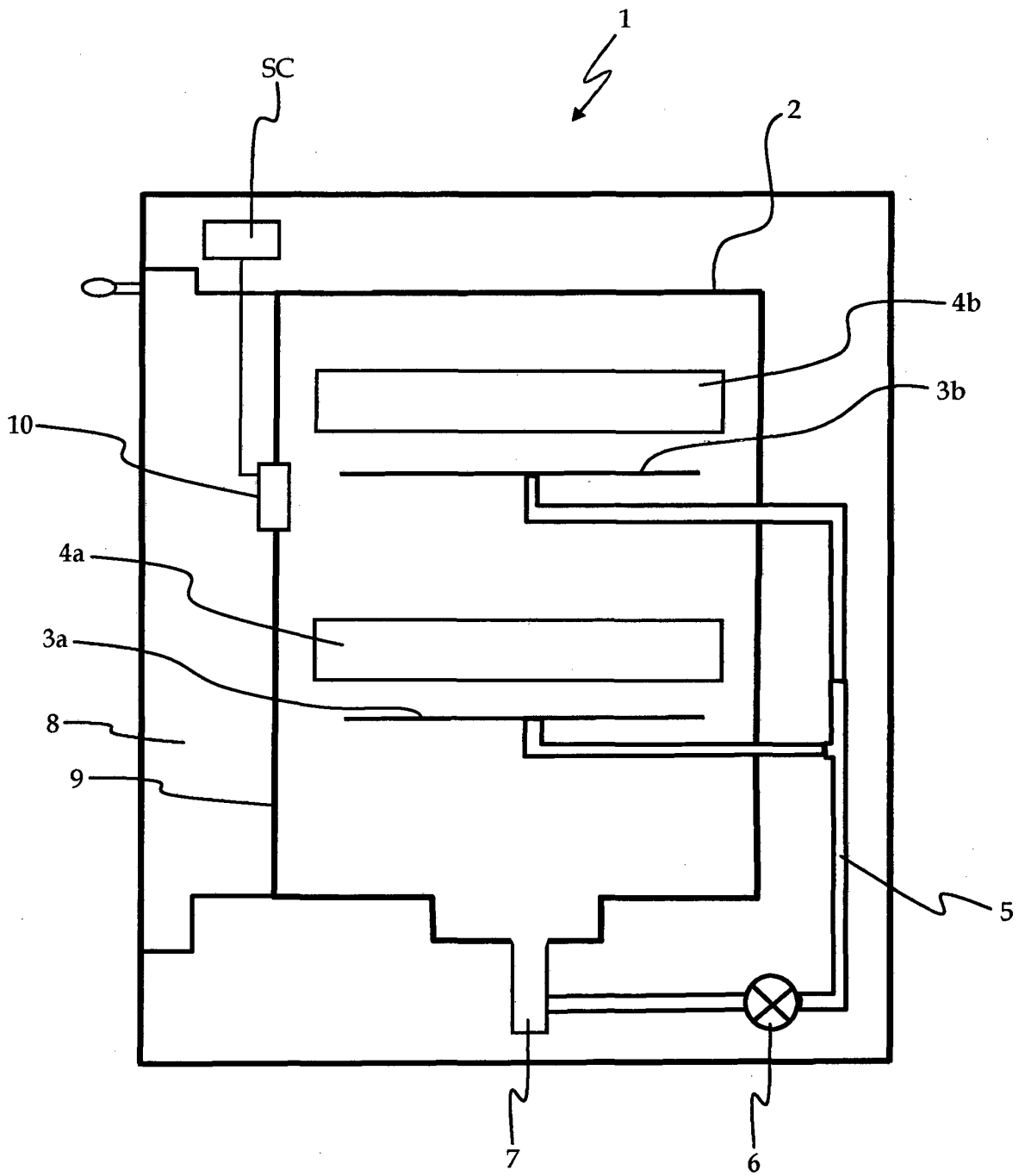

Fig. 1

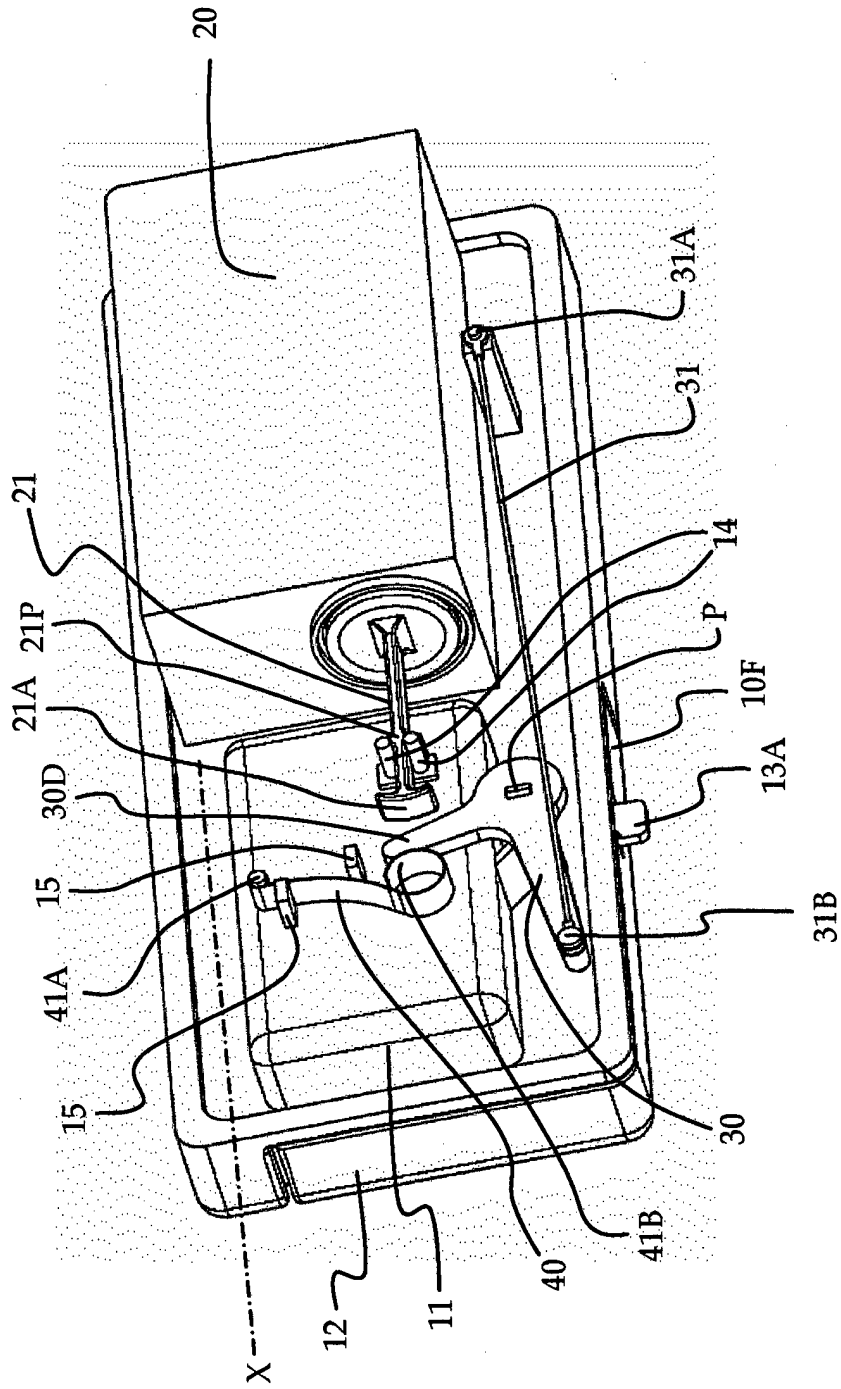

Fig. 2

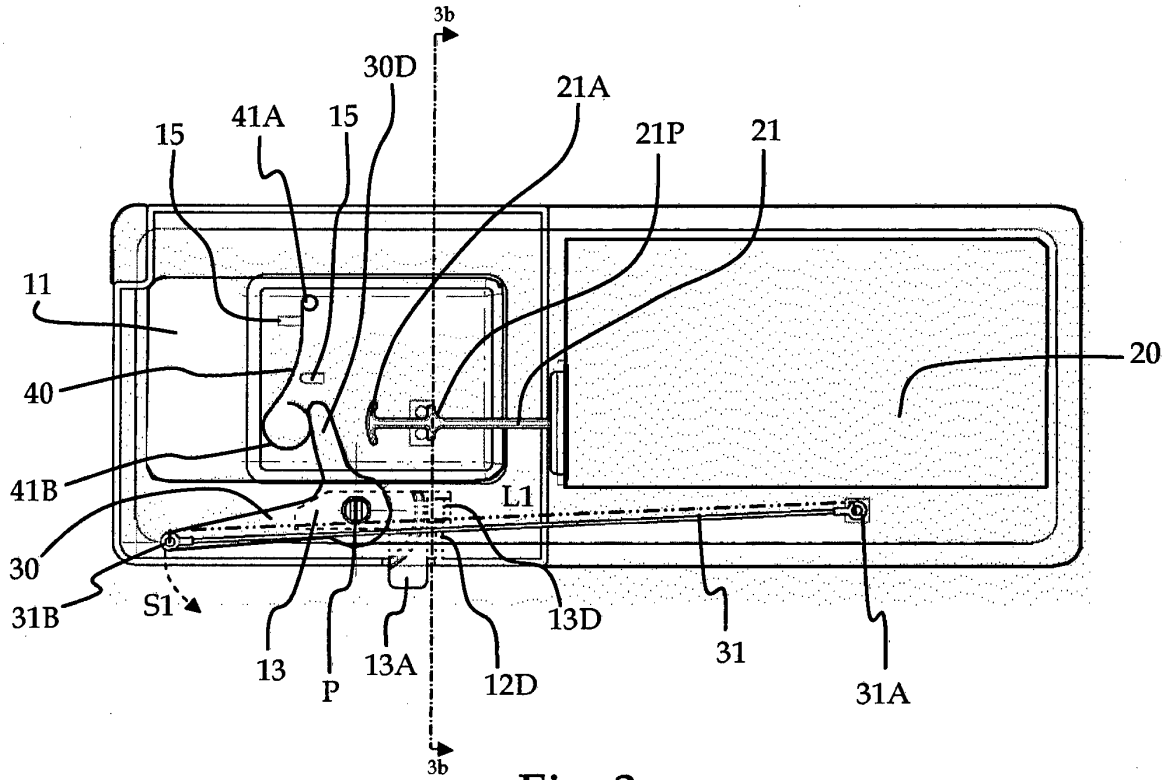

Fig. 3a

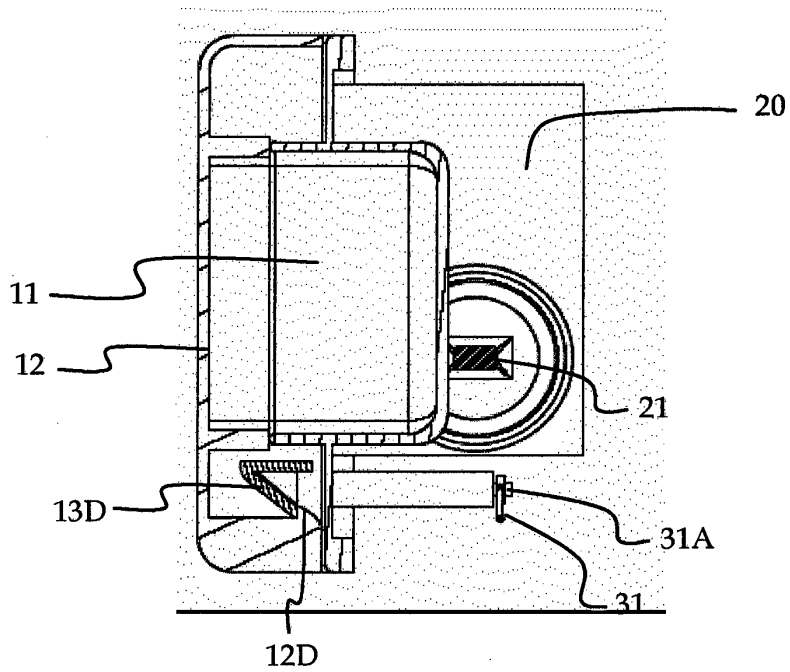

Fig. 3b

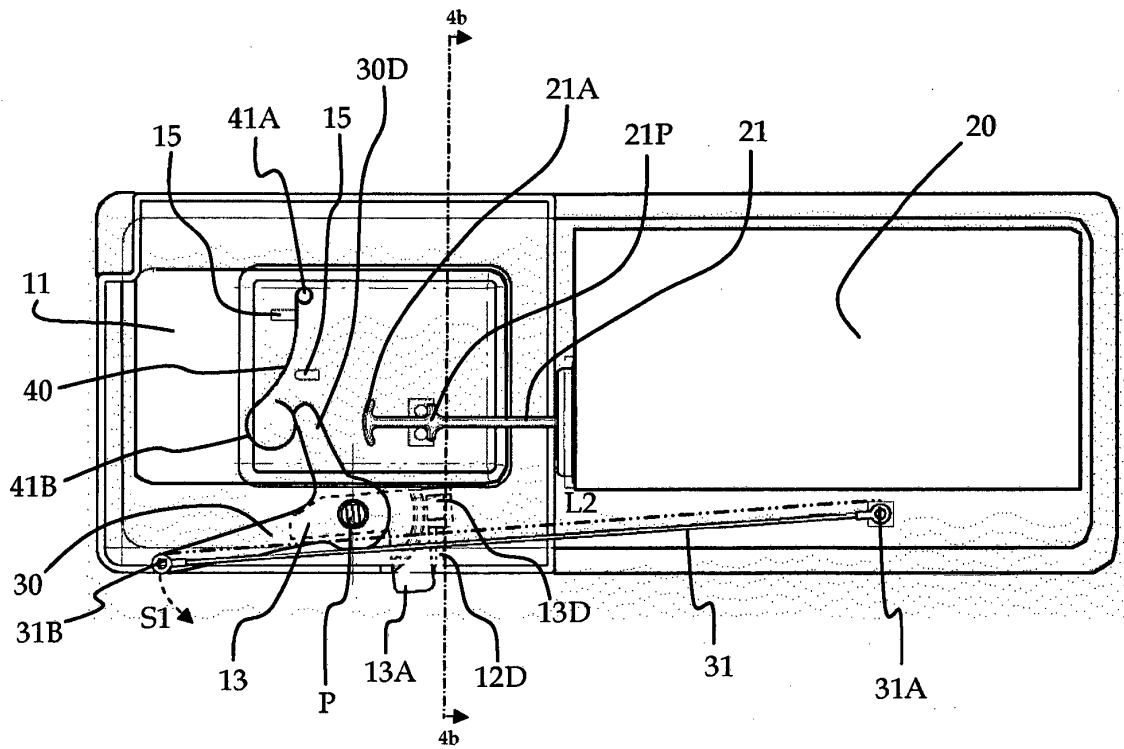

Fig. 4a

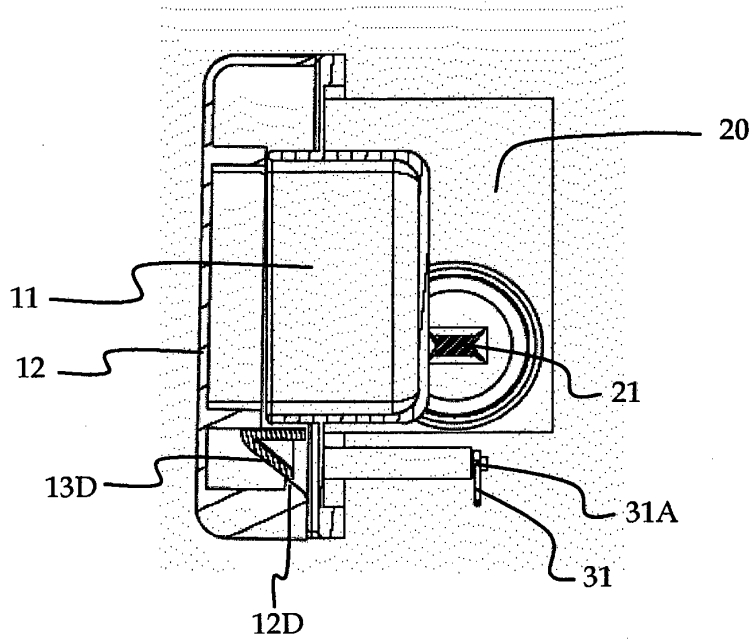

Fig. 4b

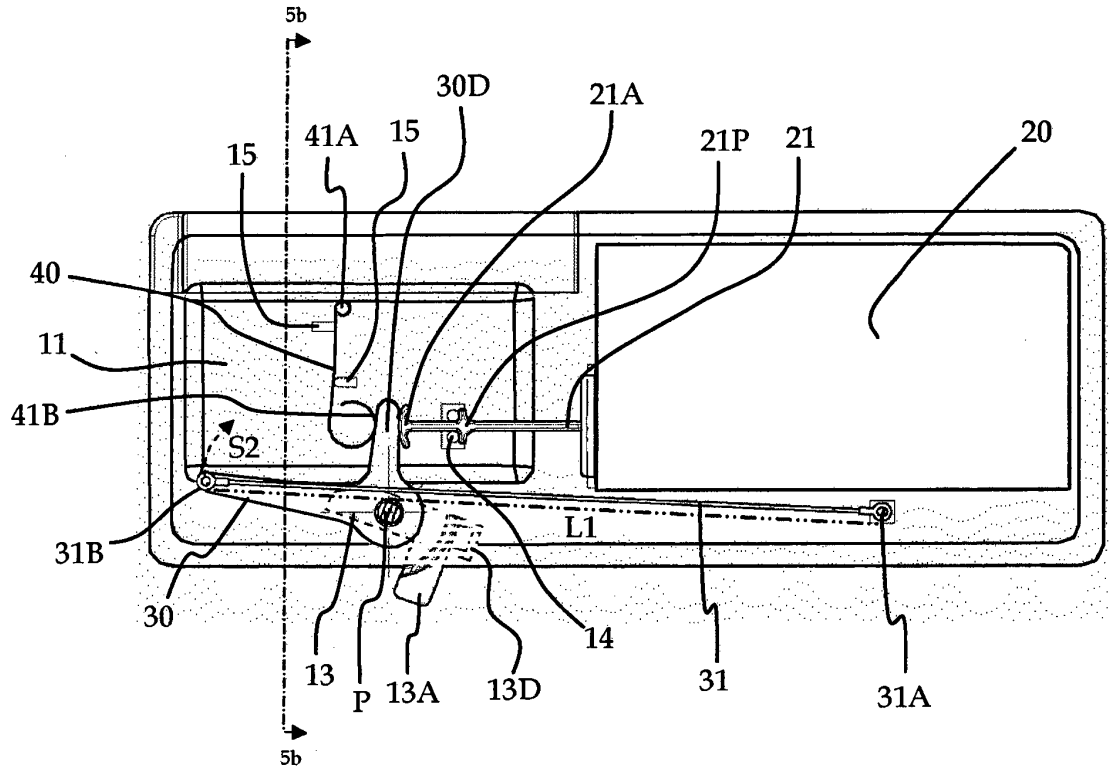

Fig. 5a

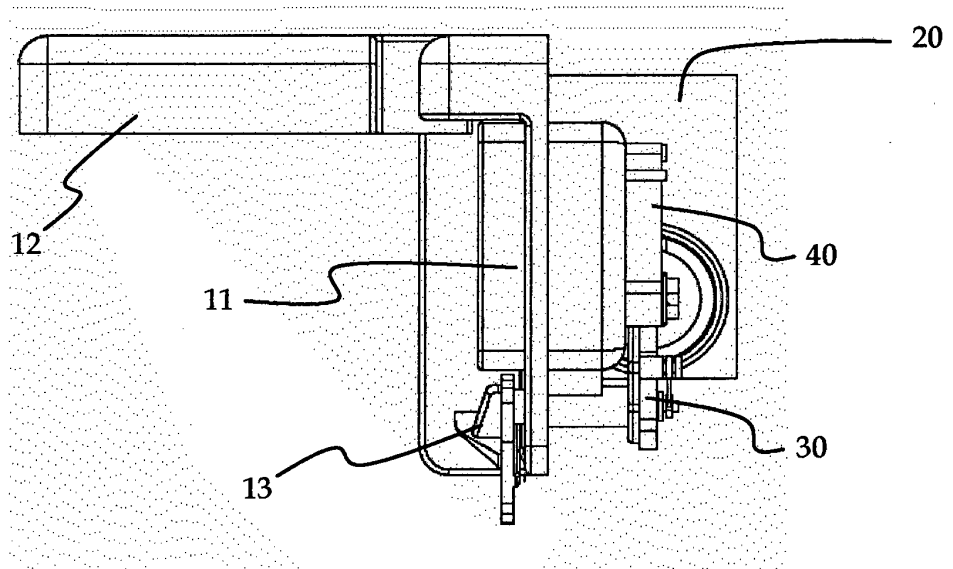

Fig. 5b

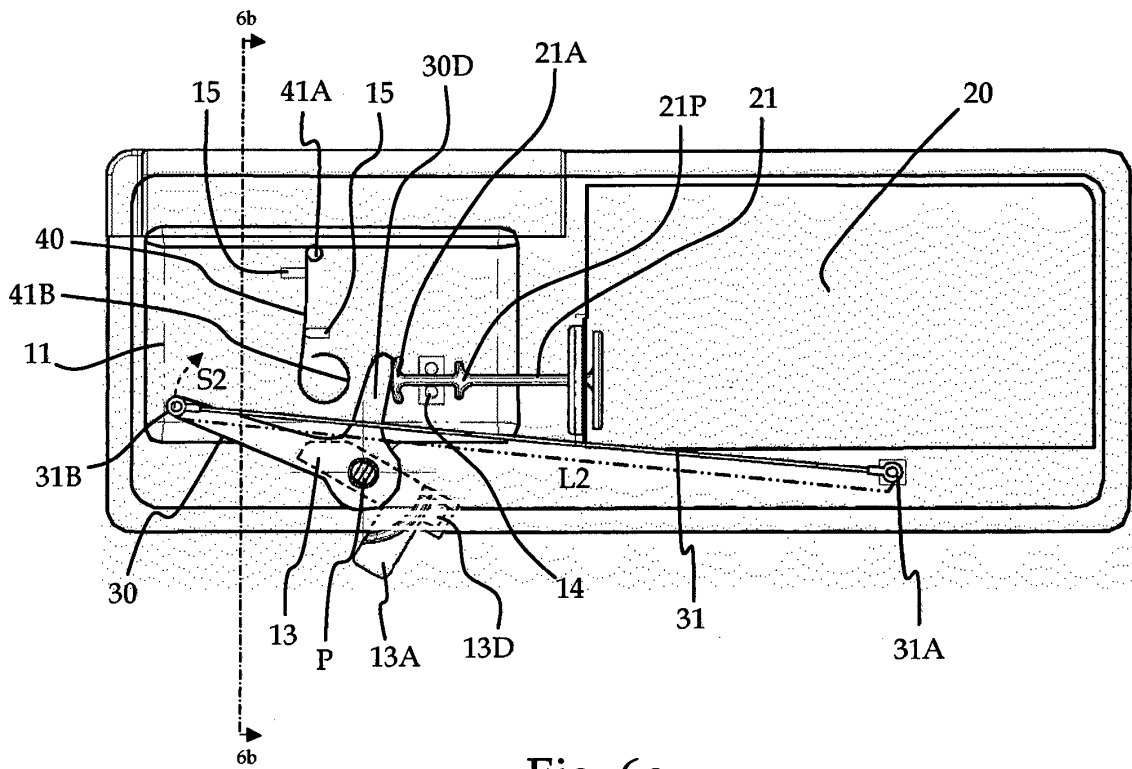

Fig. 6a

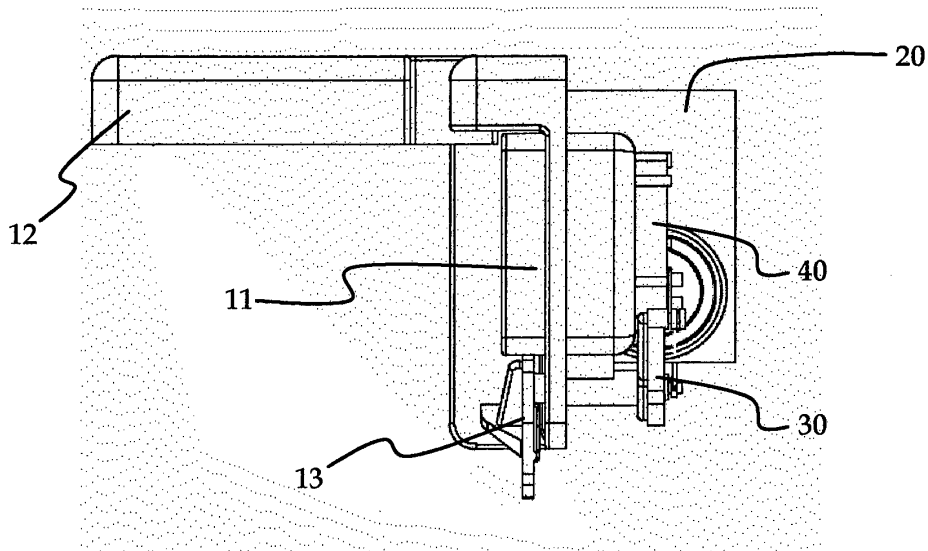

Fig. 6b

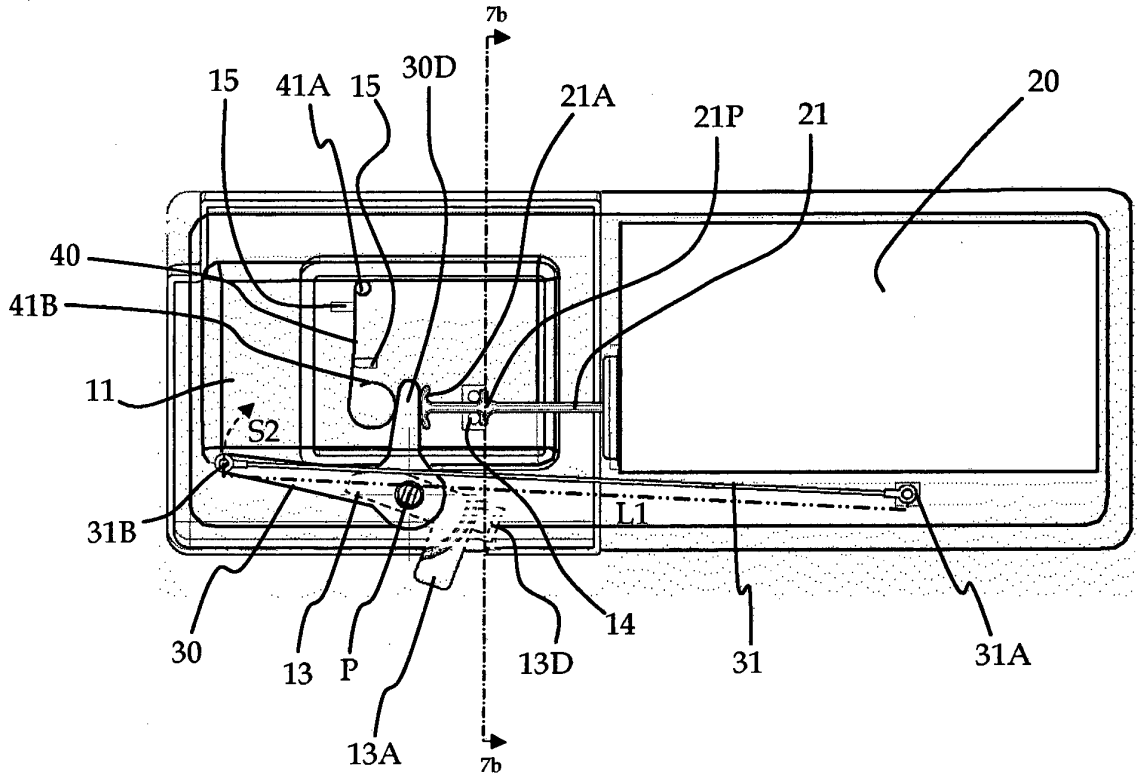

Fig. 7a

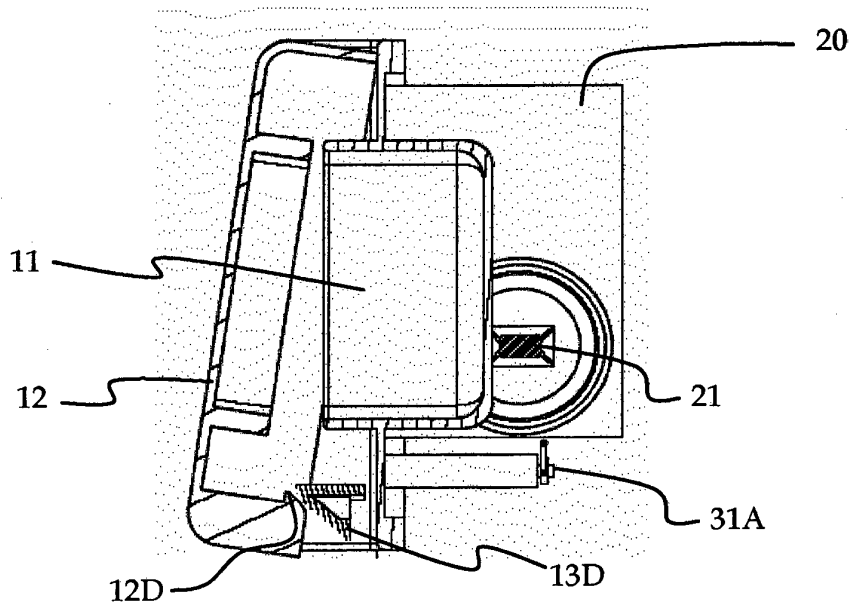

Fig. 7b

**REFERENCES CITED IN THE DESCRIPTION**

*This list of references cited by the applicant is for the reader's convenience only. It does not form part of the European patent document. Even though great care has been taken in compiling the references, errors or omissions cannot be excluded and the EPO disclaims all liability in this regard.*

**Patent documents cited in the description**

- US 3827600 A [0001]
- US 2004118434 A [0014] [0016] [0017]