

# United States Patent

[11] 3,582,084

[72] Inventors **John W. Ryan**  
**Bel Air;**  
**Richard Shih-Teng Chang, Gardena, both**  
**of, Calif.**  
 [21] Appl. No. **595,132**  
 [22] Filed **Nov. 17, 1966**  
 [45] Patented **June 1, 1971**  
 [73] Assignee **Mattel, Inc.**  
**Hawthorne, Calif.**

1,487,913	3/1924	Belt.....	274/1.5
2,212,623	8/1940	Strauss.....	274/1.1
2,238,412	4/1941	Daniel.....	274/1.1
2,622,700	12/1952	Geyer.....	185/37
3,017,187	1/1962	Ryan.....	274/1.1
3,033,336	5/1962	Kinsman.....	192/415
3,162,980	12/1964	Hellman.....	274/1.1
3,285,609	11/1966	Hiller.....	274/1.1
3,285,612	4/1965	Hallamore.....	27/11.12

**FOREIGN PATENTS**

6,220	1906	England.....	274/1.1
-------	------	--------------	---------

*Primary Examiner*—Harry N. Haroian  
*Attorney*—Seymour A. Scholnick

[54] **DEVICE FOR REPRODUCING RECORDED  
 SOUNDS IN TOYS**  
**7 Claims, 13 Drawing Figs.**

[52] U.S. Cl..... 274/11,  
 274/1

[51] Int. Cl..... G11b 25/06

[50] Field of Search..... 274/1.1, 11,  
 11.12, 43, 1.5; 46/117, 118, 232; 192/415

[56] **References Cited**  
**UNITED STATES PATENTS**

1,979,067 10/1934 Franklin..... 274/1.1

**ABSTRACT:** A constant tension spring motor arranged to advance, from one drum to another, a tape having a plurality of groove sound tracks, a needle and speaker reproduces the sound from one of the tracks when the tape advances in one direction but is free of the tape when it is returned in the other direction. A drawstring is used to wind the motor and return the tape in the other direction and tension in the drawstring also acts to retract the tape from contact with the needle.

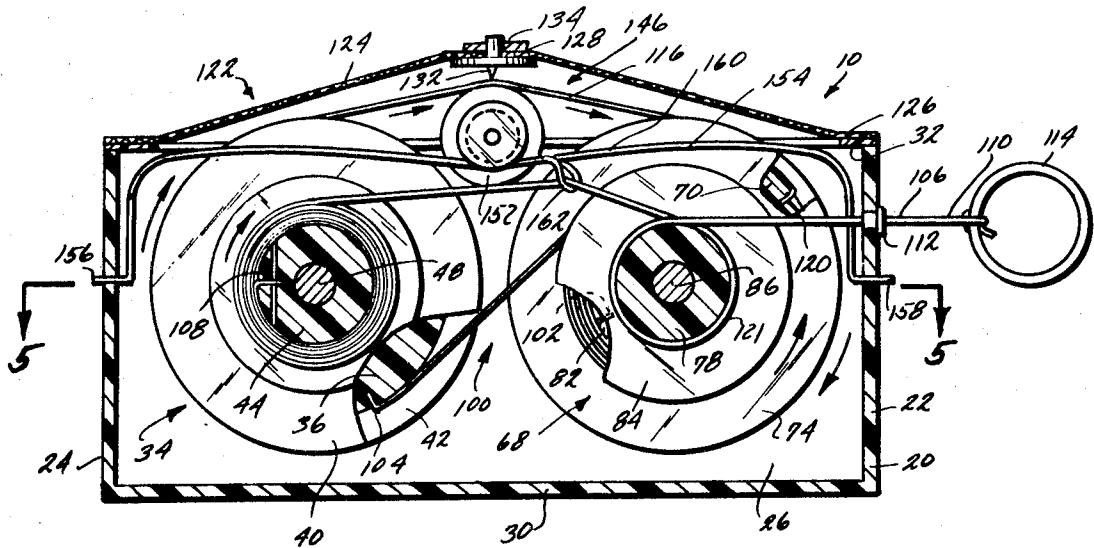



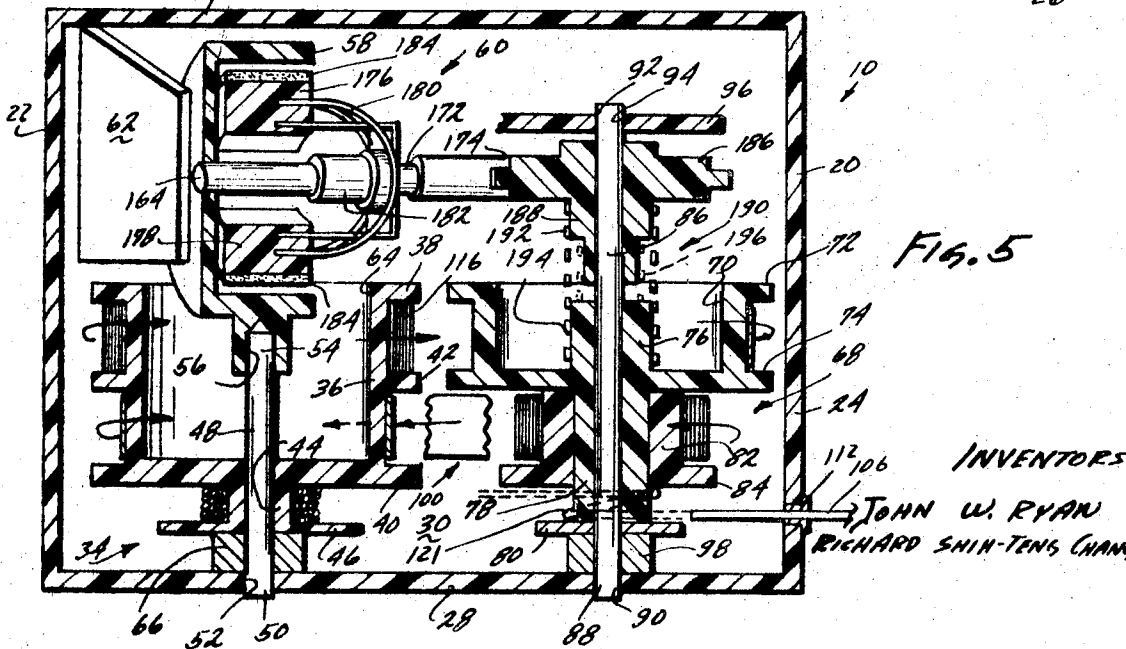
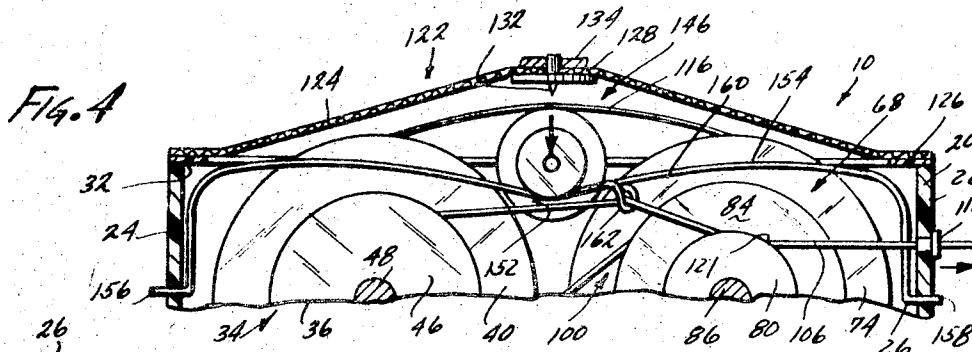
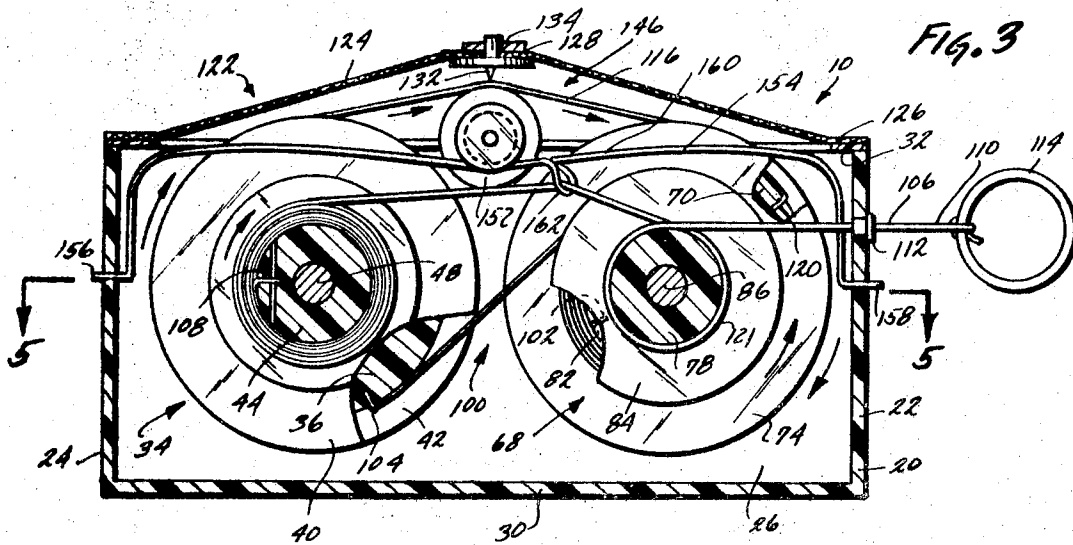

*Walter Blackham*  
ATTORNEYS

FIG. 13

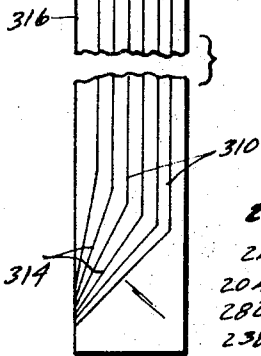
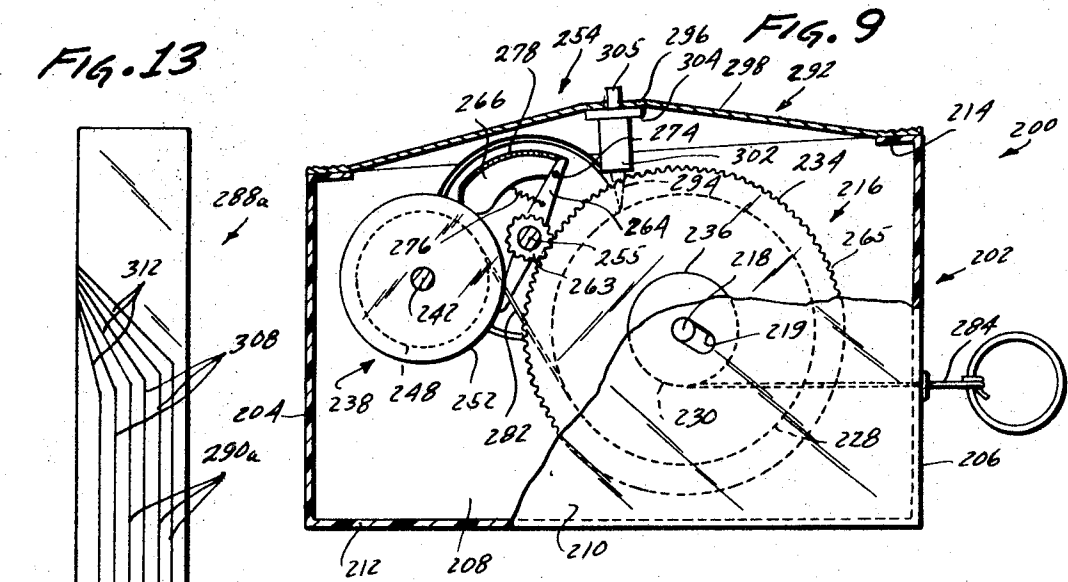

FIG. 10

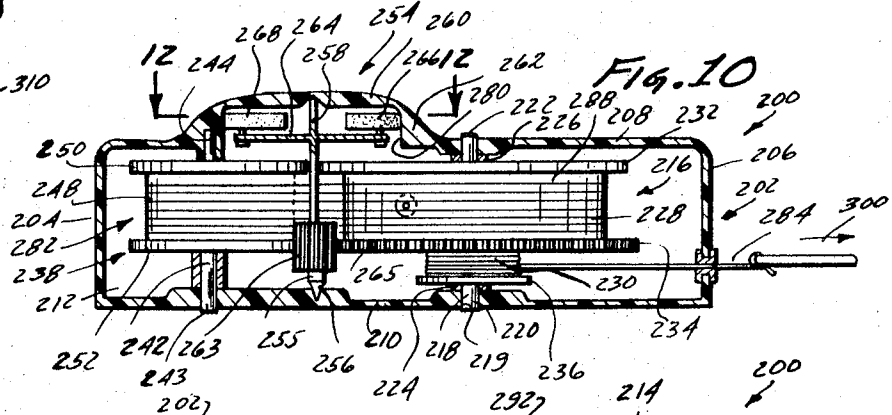
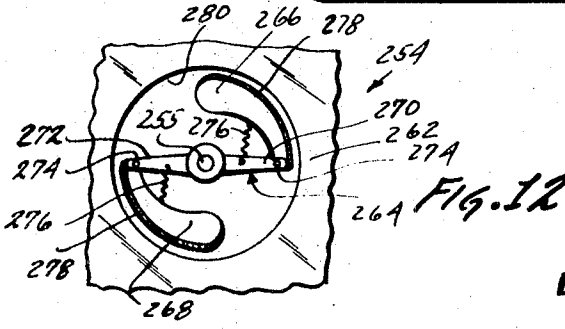
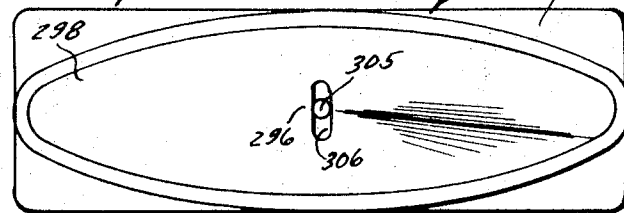

FIG. 11



INVENTORS  
 JOHN W. RYAN  
 RICHARD SHIN-TENG CHANG

BY *Hertzig, Woldt & Blackham*  
 ATTORNEYS

## DEVICE FOR REPRODUCING RECORDED SOUNDS IN TOYS

The present invention relates to a device for reproducing recorded sounds in toys and more particularly to a compact, durable sound-producing means in combination with a toy for reproducing recorded sounds which are characteristic of the toy.

Many prior art devices for reproducing recorded sounds in toys are known. In one such device, a plurality of discrete sounds are recorded on a disc-type phonograph record forming a part of a phonograph device which may be mounted inside a toy. While generally satisfactory, this type of sound-producing means has the disadvantage that the diameter of the phonograph record becomes impractical for small toys, such as small dolls and stuffed figure toys and the like, when more than a small number of recorded messages are provided on the phonograph record.

Accordingly, it is a primary object of the present invention to provide a compact, durable sound-producing means in combination with a toy for producing sounds characteristic of the toy.

Another object of the present invention is to provide a device of the type described which includes a flexible, elongated, recorded-message carrier means operatively associated with a power-drum means and a takeup drum means in such a manner that the carrier means may be wound from one of said drum means to the other of said drum means during operation of the device by a constant-force spring means of the present invention.

A further object of the present invention is to provide a new and useful device for reproducing recorded sounds in toys wherein a recorded-message carrier is integral with a spring means employed to furnish driving power for the device.

According to the present invention, a new and useful compact, durable sound-producing means is mounted in a doll for producing sounds characteristic of the doll. The device includes a power-drum means rotatably mounted in the doll, takeup drum means rotatably mounted in the doll closely adjacent the power-drum means, spring means normally biased to wind itself on the takeup drum means and having an end operatively associated with the power-drum means. Means are operatively associated with the power-drum means for winding the spring means thereon to store the energy and a flexible, elongated recorded-message carrier means is operatively associated with the second takeup drum means. The carrier means is normally wound on one of the drum means and is transferred to the other drum means during the winding of the spring means onto the power-drum means for storing said energy. The carrier means is then returned to said one drum means during the return of the spring means. Recorded sounds characteristic of the doll are provided on the message-carrier means and sound-reproducing means are operatively associated with the carrier means for reproducing the recorded sounds.

Governor means are provided in operative association with one of the drum means for controlling the rate that the recorded-message carrier means is returned to said one drum means. In a first embodiment of the invention, the recorded-message carrier means is provided in the form of an elongated, plastic tape upon which messages are recorded. This tape is wound on the power-drum means normally and is transferred to the takeup drum means during winding of the power drum to transfer the spring means thereto. When the power drum is then released, the energy stored in the spring means will rotate the power drum and return the tape to the takeup drum.

The sound-reproducing means includes a phonograph needle which is placed in the path of travel of the tape as it is returned to the takeup drum means. A plurality of different messages may be recorded on the tape in parallel, spaced-apart grooves and the needle may be shifted from one groove to another by a lever means connected thereto.

In a second embodiment of the present invention, the recorded-message carrier means is formed integrally with the spring means and may comprise a plastic coating bonded

thereto. In this embodiment, a plurality of different messages are recorded on the carrier means in parallel grooves and a means of random selection of grooves is effected by turning the beginning and ending of each groove outwardly to one edge of the carrier means. When the carrier means is started, the groove engaged by the needle depends on the instant the needle makes contact with the carrier means.

The features of the present invention which are believed to be novel are set forth with particularity in the appended claims. The present invention, both as to its organization and manner of operation, together with further objects and advantages thereof, may best be understood by reference to the following description, taken in connection with the accompanying drawings in which like reference characters refer to like elements in the several views.

### IN THE DRAWINGS

FIG. 1 is a perspective view of a sound-producing means of the present invention in combination with a doll for producing sounds characteristic of the doll;

FIG. 2 is an enlarged, partial perspective view, with parts broken away to show internal construction, of the sound-producing means of FIG. 1;

FIG. 3 is an enlarged, cross-sectional view of the sound-producing means of FIG. 1 showing the relative location of the various parts thereof during one phase of operation;

FIG. 4 is a partial view similar to FIG. 3 showing the relative location of the parts during another phase of the operation of the device;

FIG. 5 is a cross-sectional view taken along line 5-5 of FIG. 3;

FIG. 6 is an enlarged, partial perspective view of a section of the message-carrier means employed in the sound producing means of FIG. 1;

FIG. 7 is a partial, plan view of the device shown in FIG. 3;

FIG. 8 is an enlarged, partial perspective view of a section of a unitary message-carrier and spring means employed in a sound-producing means constituting a second embodiment of the invention and shown in FIGS. 9-11;

FIG. 9 is an elevational view, with parts broken away to show internal construction, of a second embodiment of a sound-producing means of the present invention;

FIG. 10 is a horizontal cross-sectional view of the device of FIG. 9;

FIG. 11 is a plan view of the device of FIG. 9;

FIG. 12 is a partial cross-sectional view taken along line 12-12 of FIG. 10; and

FIG. 13 is an enlarged, partial plan view of a modified message-carrier means which may be employed in the sound producing means of FIG. 9.

Referring again to the drawings and more particularly to FIGS. 1-7, a sound-producing means constituting a first embodiment of the present invention, generally designated 10, is shown in combination with a toy 12 which is shown herein for purposes of illustration, but not of limitation, as comprising a doll having a torso 14 including an encompassing sidewall 16. The sound producing means 10 is mounted inside the torso 14 and is secured thereto by a bracket 18 connecting the sound-producing means 10 to the sidewall 16.

The sound-producing means 10 includes a housing 20 having opposed end walls 22, 24, upstanding sidewalls 26, 28, a closed bottom wall 30 and an open top 32. The sound-producing means 10 also includes a power-drum means 34 having a first hub 36, end flanges or discs 38, 40 and an intermediate flange or disc 42. The power-drum means 34 also has a second hub 44 and a small-diameter end flange 46. The power-drum means 34 is rotatably mounted on a shaft 48 having one end 50 seated in an aperture 52 provided in the sidewall 28 and another end 54 seated in a hollow boss 56 formed on a housing 58 of a governor means 60. The housing 58 is supported from the bottom wall 30 by a flange 62 and extends into a recess 64 provided in the power-drum means 34. Disposing a portion of

the housing 58 in the recess 64 is an important feature of the present invention because it minimizes the space required in the housing 20 for the governor means 60 making the sound-producing means 10 compact. The power-drum means 34 is maintained in spaced relation with the sidewall 28 by a spacer 66 mounted on the end 50 of shaft 48 between the flange 46 and the sidewall 28.

The sound-producing means 10 also includes a takeup drum means 68 having a first large-diameter hub portion 70, first end flanges 72, 74, a first small-diameter hub portion 76, a second small-diameter hub portion 78 and a first small-diameter end flange 80. The takeup drum means 68 also has a second large-diameter hub portion 82 rotatably mounted on the second small-diameter hub 78 and an intermediate flange 84. The takeup drum means 68 is rotatably mounted on a shaft 86 having a first end 88 seated in an aperture 90 provided in the sidewall 28 and a second end 92 seated in an aperture 94 provided in a partition 96 supported by the bottom wall 30. The takeup drum means 68 is maintained in spaced relation with the sidewall 28 by a spacer 98 mounted on shaft 86 between the flange 80 and the sidewall 28.

The sound-producing means 10 also includes a constant-force spring means 100 normally biased to wind itself on the takeup drum means 68 having an end 102 affixed to the second large-diameter drum 82. The spring means 100 includes another end 104 affixed to the hub 36 of power-drum means 34 in operative association therewith. The spring means 100 is adapted to be wound on the power-drum means 34 against the normal bias in the spring means 100 for storing energy by pulling a drawstring 106 having an end 108 affixed to the hub 44 and an end 110 extending through an eyelet 112 provided in the end wall 22. A pull-ring 114 is affixed to the end 110 and may be gripped by a user of the sound-producing means 10 to rotate the power-drum means 34 in a clockwise direction, as viewed in FIG. 3, by unwinding the drawstring 106 from the hub 44. This transfers the spring means 100 from the takeup drum means 68 to the power-drum means 34 against the normal bias in the spring means 100 for storing energy therein. When the drawstring 106 is released, this stored energy rotates the power-drum means 34 for transferring a recorded-message carrier means 116 from the takeup drum means 68 to the power-drum means 34.

The recorded-message carrier means 116 may comprise an elongated strip of a plastic material upon which suitable sounds are recorded. As shown in FIG. 6, the recorded-message carrier means 116 may be provided with a plurality of mechanically recorded sound tracks 118 which may extend the full length of the recorded-message carrier means 116 is normally wound on the power-drum means 34 and includes an end 120 affixed to the first large-diameter hub portion 70 on the takeup drum means 68. The carrier means 116 may be transferred to the takeup drum means 68 by pulling the drawstring 106 tensioning a looped portion 121 into tight frictional engagement with the second small-diameter hub portion 78 for imparting rotation thereto. Thus, when the drawstring 106 is pulled to transfer the spring means 100 to the power-drum means 34, the carrier means 116 is simultaneously transferred from the power-drum means 34 to the takeup drum means 68. The rotation imparted to the power-drum means 34 by the spring means 100 upon release of the drawstring 106 then transfers the carrier means 116 from the takeup drum means 68 to the power-drum means 34. During this transfer operation, the sounds recorded on the carrier means 116 may be reproduced by a sound-reproducing means 122 affixed to the housing 20 adjacent the open top 32 in operative association with the carrier means 116.

The sound-reproducing means 122 includes a speaker cone 124 having a corrugated edge portion 126 affixed to the housing 20 and an apex portion 128. The apex portion 128 is provided with an arcuate slot 130 in which a phonograph needle 132 is mounted for tracing the soundtracks 118. The needle 132 may be shifted from one soundtrack to another by a lever means 134 (FIG. 7) having one end 136 pivotally connected

to a bracket 138 on the housing 20 by a pivot pin 140 and another end 142 provided with a slot 144 holding the needle 132 captive. The carrier means 116 is pressed into operative engagement with the needle 132 by a mandrel means 146 having one end (not shown) journaled in the sidewall 26 and another end 148 journaled in a U-shaped opening 150 provided in the sidewall 28. The mandrel means 146 includes a roller 152 adapted to be urged into engagement with the carrier means 116 by a spring means 154 having a first end 156 connected to the end wall 24 and a second end 158 connected to the end wall 22. The spring means 154 includes an upwardly bowed midportion 160 urging the end 148 of mandrel means 146 upwardly in the U-shaped opening 150. The spring means 154 also includes a looped portion 162 forming an eyelet about the drawstring 106 so that tensioning of the drawstring 106 lowers the bowed portion 160 to the position shown in FIG. 4 for bringing the carrier means 116 out of engagement with the needle 132 during transfer of the carrier means 116 from the power-drum means 34 to the takeup drum means 68.

The rate of travel of the carrier means 116 is controlled by the governor means 60 which includes a spindle 164 having an end 166 journaled in an aperture 168 provided in the end wall 170 of housing 58 and an end 172 which carries a worm gear 174 for imparting rotation to the spindle 164. The governor means 60 also includes a pair of weights 176, 178 connected to the spindle 164 by U-shaped spring means 180 and a hub 182. Each weight 176, 178 carries a felt pad 184 adapted to be urged into engagement with the housing 58 against the restraining force of spring 180 when the spindle 164 reaches a predetermined operating speed. The worm gear 174 is driven by a gear 186 which is rotatably mounted on the shaft 86. The gear 186 includes a hub 188 which is connected to the first small-diameter hub portion 76 by a spring clutch means 190 having a first end 192 connected to the hub 188 and a second end 194 connected to the hub portion 76. A reduced diameter intermediate portion 196 of hub 188 allows the spring clutch means 190 to wind inwards slightly when torque is applied to hub 76. The clutch means 190 not only performs a clutching function between the takeup drum means 68 and the gear 186, but also comprises a compliant coupling therebetween for minimizing the transfer of vibrations from the gears 174 and 186 to the carrier means 116. The clutch means 190 comprises a helical spring which loosens its grip on the hubs 76 and 188 during rotation of the large-diameter hub 70 by the drawstring 106 in one direction and firmly grips the hubs 76 and 188 to rotate the governor means 60 at high speed when the hub 70 is rotated in the other direction by the power-drum means 34 winding the carrier means 116 thereupon.

In use, a child user of the toy 12 may grasp the ring 114 and pull the drawstring 106 to transfer the spring means 100 from the takeup drum means 68 to the power-drum means 34 and simultaneously transfer the carrier means 116 from the power-drum means 34 to the takeup drum means 68. During this operation, the looped portion 121 of the drawstring 106 will rotate the first small-diameter hub 76 in such a direction that the end 194 of clutch means 190 will not grip the hub 76 with sufficient force to rotate the gear 186. After the drawstring 106 has been pulled to the end of its travel, it may be released whereupon the energy stored in spring means 100 on the power-drum means 34 will impart rotation thereto pulling the carrier means 116 from the takeup drum means 68 and winding it upon power-drum means 34. This rotates the hub 76 in such a direction that the end 194 of clutch means 190 is brought into firm engagement with hub 76 for imparting rotation to the gear 186 which, in turn, rotates the worm gear 174 at high speed bringing the governor means 60 into play for controlling the rate of travel of the carrier means 116. As the carrier means 116 travels from the takeup drum means 68 to the power-drum means 34, the needle 132 traces the soundtrack 118 selected by swinging the lever 134 for transmitting vibrations from the sound track 118 to the speaker cone 124.

Referring now to FIGS. 8-12, a sound-producing means constituting a second embodiment of the present invention, generally designated 200, may be attached to the bracket 18 in the toy 12 in place of the sound-producing means 10 and includes a housing 202 having end walls 204, 206, sidewalls 208, 210, a bottom wall 212 and an open top 214.

A power-drum means 216 is rotatably mounted in the housing 202 on a shaft 218 having an end 220 rotatably mounted in a slot 219 provided in the sidewall 210 and a second end 222 journaled in the sidewall 208. The power-drum means 216 is spaced from the sidewalls 210 and 208 by spacer means 224 and 226, respectively, and includes a large-diameter hub 228, a small-diameter hub 230 and associated flanges 232, 234 and 236.

The sound-producing means 200 also includes a takeup drum means 238 which is rotatably mounted in the housing 202 by a shaft 242 having a first end 243 journaled in the sidewall 210 and a second end 244 journaled in the sidewall 208. The takeup drum means 238 includes a hub 248 and associated end flanges 250 and 252.

The sound-producing means 200 also includes a governor means 254 having a spindle 255 rotatably mounted in the housing 202 with a first end 256 journaled in the sidewall 210 and a second end 258 journaled in a wall 260 of a governor housing 262 formed on the sidewall 208. The governor means 254 includes a pinion gear 263 and a crossarm 264 which may be formed integrally with the spindle 255. The pinion gear 263 drivably engages a ring gear 265, formed on the flange 234 of drum means 216, for rotation thereby. The governor means 254 also includes a pair of weights 266, 268 which are swingably connected to the ends 270, 272, respectively, of arm 264 by pins 274. The weights 266, 268 are biased toward the spindle 255 by associated spring means 276 and are provided with felt pads 278 adapted to engage the inner wall 280 of housing 262 when subjected to sufficient centrifugal force upon rotation of the arm 264 by drum 216 through gears 265 and 263 and spindle 255. The drum 216 is rotated by the force stored in a constant-force spring means 282. The spring means 282 is normally biased to wind itself on the takeup drum means 238 and may be transferred from drum means 238 to drum means 216 by a drawstring 284 which is normally wound about the hub 230.

The sound-producing means 200 also includes a recorded-message carrier means 288 which is shown for purposes of illustration, but not of limitation, as comprising a suitable plastic member bonded to the spring means 282. The carrier means 288 is provided with a plurality of recorded sound grooves or tracks 290 operatively associated with a sound-reproducing means 292 including a needle 294 mounted in the apex portion 296 of a speaker cone 298. When the drawstring 284 is pulled in the direction of arrow 300, the drawstring 284 moves the end 220 of shaft 218 downwardly in the slotted aperture 219 lowering the carrier means 288 out of engagement with the needle 294. The needle 294 includes a carrier 302 having an annular shoulder 304 engaged under the apex 296 of cone 298 and an upstanding pin 305 extending through a slotted aperture 306 provided in the apex 296 for permitting limited lateral movement of needle 294 with respect to the grooves 290.

Unwanted vibrations between the governor weights 266, 268 and carrier means 288 may be minimized by making the arm 264 in the form of a compliant coupling.

Referring now to FIG. 13, a modified recorded-message carrier means 288a may be identical to the carrier means 288 except that the leading ends 308 and the trailing ends 310 of a plurality of soundtracks 290a are connected by lead-in grooves 312 and lead-out grooves 314, respectively, to an edge 316 of carrier means 288a. The lead-out grooves 314 move the needle 294 laterally in aperture 306 to a position superjacent the edge 316. The lead-in grooves 312 will then be selected randomly for moving the needle 294 onto a particular sound track 290a, depending on the exact point of engagement of the needle 294 with carrier means 288a when the

drawstring 284 is released after transferring spring means 282 onto drum means 216.

While the particular sound-producing means herein shown and described in detail are fully capable of attaining the objects and providing the advantages hereinbefore stated, it is to be understood that they are merely illustrative of the presently preferred embodiments of the invention and that no limitations are intended to the details of construction or design herein shown other than as defined in the appended claims.

What we claim is:

1. In combination with a toy, a compact, durable sound-producing mechanism for producing sounds characteristic of said toy, comprising:

power-drum means rotatably mounted in said toy;

takeup means mounted in said toy adjacent said power-drum means, said takeup means including takeup drum means rotatably mounted in said toy;

spring means normally biased to wind itself on said takeup means and having an end wound on said power-drum means, said spring means being adapted to be wound on said power-drum means against said bias for storing energy to rotate said power-drum means during return of said spring means to its normally wound condition on said takeup means;

manually operable means operatively connected to said power-drum means for winding said spring means onto said power-drum means to store said energy;

separate elongated, recorded-message carrier means having end portions respectively wound on said power and takeup drum means laterally adjacent said spring means, and extending between said power-drum means and said takeup drum means along one side of said mechanism, said carrier means being a flexible band normally wound on said power-drum means, being transferred to said takeup drum means by rotation thereof during the winding of said spring means onto said power-drum means for storing said energy, and being returned to said power-drum means during said return of said spring means, said carrier means having sounds recorded in a sound track groove thereon, characteristic of said toy;

sound-reproducing means on said one side of said mechanism and including a phonograph needle between said drum means engageable in said groove; and

means responsive to actuation of said manually operable means for withdrawing said carrier means from said needle so as to disengage said needle from said sound track groove during winding of said spring means on said power-drum means.

2. A combination as stated in claim 1 wherein said carrier means has a plurality of parallel soundtracks extending lengthwise thereon including a lead-in groove extending from one end of each soundtrack to one edge of said elongated carrier means for randomly associating said needle with said soundtracks.

3. A combination as stated in claim 13 wherein said spring means comprises a constant-torque spring.

4. The combination defined in claim 1 wherein said manually operable means comprises a drawstring for rotating said power drum, said means for withdrawing said carrier from said needle being responsive to tension in said drawstring.

5. In combination with a toy, a compact, durable sound-producing mechanism for producing sounds characteristic of said toy, comprising:

power-drum means rotatably mounted in said toy;

takeup means mounted in said toy adjacent said power-drum means, said takeup means including takeup drum means rotatably mounted in said toy;

spring means normally biased to wind itself on said takeup means; said spring means having an end wound on said power-drum means, said spring means being adapted to be wound on said power-drum means against said bias for storing energy to rotate said power-drum means during return of said spring means to its normally wound condition on said takeup means;

manually operable means operatively connected to at least one of said drum means for winding said spring means onto said power-drum means to store said energy;  
 separate elongated, recorded-message carrier means having end portions respectively wound on said power and takeup drum means laterally adjacent said spring means, and extending between said power-drum means and said takeup drum means along one side of said mechanism, said carrier means being a flexible band normally wound on power-drum means, being transferred to said takeup drum means by rotation thereof during the winding of said spring means onto said power-drum means for storing said energy, and being returned to said power-drum means during said return of said spring means, said carrier means having sounds recorded in a soundtrack groove thereon, characteristic of said toy;  
 sound-reproducing means on said one side of said mechanism and including a phonograph needle between said drum means engageable in said groove, said sound-reproducing means being mounted in a housing having an open side and including a speaker cone closing said open

side with its apex pointed outwardly, said needle being operatively connected to said cone at said apex and projecting inwardly toward said carrier means; and means responsive to actuation of said manually operable means for withdrawing said carrier means from said needle so as to disengage said needle from said soundtrack groove during winding of said spring means on said power-drum means.

6. A combination as stated in claim 5 including governor means for controlling the rate of travel of said carrier means during said return of said carrier means to said one drum means, one of said drum means including an axially recessed portion at one end thereof, said governor means including a housing having a portion extending into said recessed portion for minimizing the space within said housing required by said governor means.

7. The combination defined in claim 5 wherein a portion of said mechanism projects from said open side but is covered and enclosed by said speaker cone.

25

30

35

40

45

50

55

60

65

70

75

UNITED STATES PATENT OFFICE  
CERTIFICATE OF CORRECTION

Patent No. 3,582,084 Dated June 1, 1971

Inventor(s) John W. Ryan et al.

It is certified that error appears in the above-identified patent and that said Letters Patent are hereby corrected as shown below:

Column 4, line 37, cancel "reduced", first occurrence.

Column 6, line 56, the claim reference numeral "13" should read -- 1 --; line 60, after "drum" and before the comma insert -- means --; same line 60, after "carrier" insert -- means --.

Column 7, line 10, after "on" insert -- said --.

Column 8, line 11, "one" should read -- power --.

Signed and sealed this 25th day of April 1972.

(SEAL)  
Attest:

EDWARD M. FLETCHER, JR.  
Attesting Officer

ROBERT GOTTSCHALK  
Commissioner of Patents