

(19) World Intellectual Property Organization  
International Bureau



(43) International Publication Date  
26 July 2001 (26.07.2001)

PCT

(10) International Publication Number  
**WO 01/54076 A1**

- (51) International Patent Classification<sup>7</sup>: G07D 7/12, 7/18
- (21) International Application Number: PCT/GB01/00254
- (22) International Filing Date: 23 January 2001 (23.01.2001)
- (25) Filing Language: English
- (26) Publication Language: English
- (30) Priority Data:  
0001561.0      24 January 2000 (24.01.2000)      GB
- (71) Applicant (for all designated States except US): DE LA RUE INTERNATIONAL LIMITED [GB/GB]; De La Rue House, Jays Close, Viables, Basingstoke, Hampshire RG22 4BS (GB).
- (72) Inventor; and
- (75) Inventor/Applicant (for US only): CHRISTOPHERSEN, Bryan, James [GB/GB]; 5 Nelson Avenue, Portchester, Fareham, Hampshire PO16 9XH (GB).
- (74) Agent: GILL JENNINGS & EVERY; Broadgate House, 7 Eldon Street, London EC2M 7LH (GB).
- (81) Designated States (national): AE, AG, AL, AM, AT, AU, AZ, BA, BB, BG, BR, BY, BZ, CA, CH, CN, CR, CU, CZ, DE, DK, DM, DZ, EE, ES, FI, GB, GD, GE, GH, GM, HR, HU, ID, IL, IN, IS, JP, KE, KG, KP, KR, KZ, LC, LK, LR, LS, LT, LU, LV, MA, MD, MG, MK, MN, MW, MX, MZ, NO, NZ, PL, PT, RO, RU, SD, SE, SG, SI, SK, SL, TJ, TM, TR, TT, TZ, UA, UG, US, UZ, VN, YU, ZA, ZW.
- (84) Designated States (regional): ARIPO patent (GH, GM, KE, LS, MW, MZ, SD, SL, SZ, TZ, UG, ZW), Eurasian patent (AM, AZ, BY, KG, KZ, MD, RU, TJ, TM), European patent (AT, BE, CH, CY, DE, DK, ES, FI, FR, GB, GR, IE, IT, LU, MC, NL, PT, SE, TR), OAPI patent (BF, BJ, CF, CG, CI, CM, GA, GN, GW, ML, MR, NE, SN, TD, TG).

**Published:**  
 — with international search report  
 — before the expiration of the time limit for amending the claims and to be republished in the event of receipt of amendments

[Continued on next page]

(54) Title: DOCUMENT MONITORING METHOD

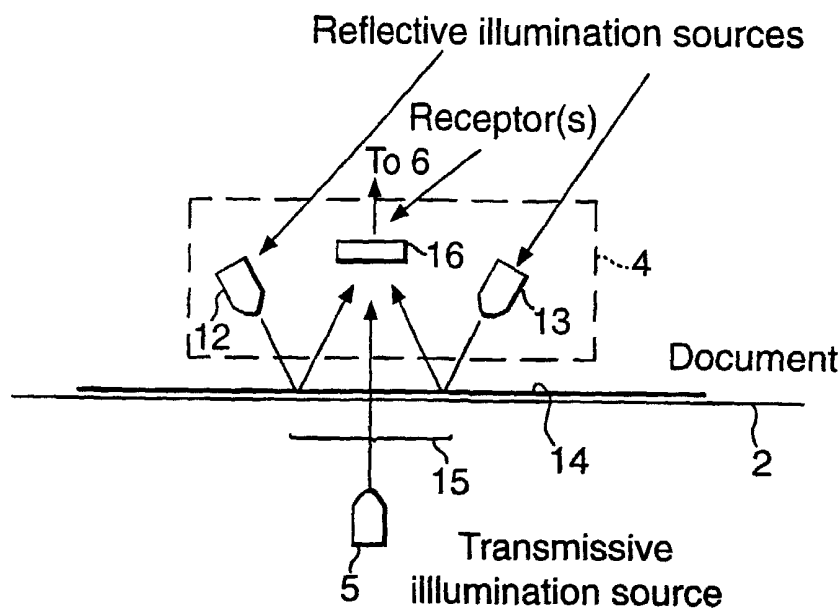

(57) Abstract: A method of inspecting documents of value, the method comprises: a) obtaining images of one or more parts of the document from radiation received from that part or those parts of the document (14) in respective different wavelength bands; b) performing an analysis of one of said images to identify a first type of class within which the document of value is included; and c) performing an analysis of another of said images using corresponding predetermined data relating to members of the first type of class identified in step b) so as to determine a second type of class within which the document of value is included.



WO 01/54076 A1



---

*For two-letter codes and other abbreviations, refer to the "Guidance Notes on Codes and Abbreviations" appearing at the beginning of each regular issue of the PCT Gazette.*

DOCUMENT MONITORING METHOD

The invention relates to a method for monitoring documents, for example documents of value such as banknotes.

Document monitoring is used in a number of different fields to obtain information about different characteristics of documents, particularly documents being fed along a transport path. These characteristics include the document condition, size and, in the case of documents of value, characteristics such as authenticity and denomination. In order to determine these characteristics, different information must be obtained from the document and traditionally the document is fed past a number of different detectors and processing environments to enable each aspect or characteristic to be determined. This is inefficient in terms of cost and space required and limits the extent of information which can be obtained.

Documents of value need to be inspected at least to determine their classification, for example their denomination and to confirm authenticity. One approach is to compare images of part or parts of the document under test obtained under predetermined illumination conditions with sets of predetermined images and determine which predetermined image most closely matches the image under test. However, the matching process is complex and thus can take a significant time while it is desirable to increase the speed of processing of documents of value, for example in banknote sorters and counters.

In accordance with the present invention, a method of inspecting documents of value comprises

- a) obtaining images of one or more parts of the document from radiation received from that part or those parts of the document in respective different wavelength bands;

- b) performing an analysis of one of said images to identify a first type of class within which the document of value is included; and
- c) performing an analysis of another of said images using corresponding predetermined data relating to members of the first type of class identified in step b) so as to determine a second type of class within which the document of value is included.

10 In this invention, we provide a two stage inspection process. In particular, following the analysis in step b), the analysis of step c) is performed using only data relating to members of the first type of class identified in step b). In general, this will constitute a much smaller number of sets of data, typically just one, so speeding up the matching process.

15 The wavelength bands may be overlapping or non-overlapping, both in the visible or both in the non-visible spectra or, preferably, one in the visible and one in the non-visible e.g. infrared or ultraviolet.

20 Typically, the first type of class defines one or more of the denomination, face and orientation of the document of value. In this case, preferably the image used in step b) is obtained from visible radiation received from the document.

25 The second type of class may define the authenticity of the document of value. In this case, the image used in step c) may be defined by radiation received from the document in a waveband outside the visible wavelength range, for example the infrared wavelength range.

30 It should be understood, however, that these class types could be reversed so that initially an authenticity classification is carried out followed by a denomination or other classification.

35 As an alternative, the second type of class may define the degree of soiling of the document of value.

In a further, preferred case, the method further comprises

- 5 d) performing an analysis of one of said images using corresponding predetermined data relating to members of the first type of class identified in step b) so as to determine a third type of class within which the document of value is included.

10 The second and third types of class can then be authenticity and degree of soiling respectively. Steps c) and d) could be carried out in parallel or sequentially and in one case, the predetermined data used in step d) could relate only to members of the second type of class identified in step c).

15 The images can be derived from different areas of the document since the discriminative and/or authenticating regions of the document may well be in different places. The data however is usually gathered at the same time.

20 The images can be obtained using conventional equipment such as described in EP-A-0660277, GB-A-2107911 and GB-A-1470737.

25 Preferably, however, step (a) is performed using a document monitoring system comprising illumination apparatus for illuminating a region, at which part of a document is located in use, with radiation in at least two different wavelength bands; and detection apparatus for detecting any of said radiation which is reflected by or transmitted through substantially the same said part of the document and for generating corresponding output signals.

30 This apparatus allows information to be obtained from a document by both reflection and transmission. By irradiating in at least two different wavelength bands, information relating to both authentication and classification can be achieved while reflected and transmitted radiation provides information about soiling and other conditions.

35

The illumination apparatus may generate the radiation at the at least two different wavelength bands simultaneously, the detection apparatus having separate detectors responsive to radiation in the different wavelength bands. Alternatively, the illumination apparatus may generate radiation in the different wavelength bands sequentially, the detection apparatus having one or more detectors responsive to radiation in all the wavelength bands.

10 In the preferred example, the illumination apparatus includes a radiation source located on the opposite side of the region to the detection apparatus for transmitting radiation through the document. However, as an alternative, the illumination apparatus may include a reflective surface in the said region and on which a document is located in use, wherein any radiation impinging on the reflective surface is reflected towards the detection apparatus.

20 In some cases, the system may include a single set of illumination apparatus and detection apparatus and the region may be chosen in accordance with the document to be monitored. Thus, the region could comprise a small region within the document or a region extending across the full dimension of the document. In the preferred case where the document is fed through the region, the region preferably extends across the full dimension of the document transverse to the feed direction.

30 In other cases, more than one set of detection and illumination apparatus may be provided to monitor different regions of the document.

The invention is particularly concerned with inspecting documents of value such as banknotes but is also applicable to visas, passports, licences, cheques, identity cards, plastic cards, bank notes, tickets, bonds, share certificates, vouchers, passes, permits, brand authentication labels, serial numbering slips, quality control certificates, bills of lading and other shipping

documentation, legal documents and tamper evident labels and the like.

Some examples of methods and apparatus according to the invention will now be described with reference to the accompanying drawings, in which:

Figures 1A and 1B are schematic diagrams of two different examples of illumination and detection apparatus according to the invention;

Figure 2 illustrates an example of a signal received at a detector of the detection apparatus as a document moves past the detector;

Figure 3 illustrates an example of a banknote being fed beneath the detection apparatus;

Figure 4 is a flow diagram illustrating operation of the signal processing system; and,

Figure 5 is a schematic view of the banknote handling apparatus.

As mentioned above, the invention can be used in a wide variety of apparatus and in this particular example we will describe its application to banknote handling apparatus, for example a banknote sorter. In this sorter, the banknotes are fed from a stack (not shown) to a feed system 1 (Figure 5) which, in this case, comprises a set of laterally spaced feed belts 2 (only one shown in Figure 5) which feed the banknote into a detection system 3. The detection system 3 comprises a detector and illumination head 4 and a further illumination source 5, the output of the detector portion of the head 4 being fed to an analogue-to-digital convertor 6 coupled to a microprocessor 7. The microprocessor 7 operates on the incoming data as will be described below and generates, if appropriate, a control signal on a line 8 to operate a diverter 9 in the path of the banknote. The diverter 9 can be arranged as shown in solid lines in Figure 5 so that the banknote passes to a downstream transport system 10 or, in the dashed line position, to allow banknotes to be fed to a store 11.

Figure 1A illustrates the detector and illumination head 4 in more detail. As can be seen, a pair of radiation sources 12,13 are provided, radiation from those sources impinging on a document 14 being fed by the belts 2. The radiation impinges on the document 14 within a region 15, all radiation reflected from within that region 15 being received by one or more detectors 16. In addition, as will be described below, the illumination source 5 generates a radiation beam which passes between the belts 2 and in the absence of the banknote 14 will be received by the detector 16.

Figure 1B illustrates a modified form of the apparatus shown in Figure 1A in which the illumination source 5 is omitted and replaced by a reflector 20 having a high reflectivity. In the absence of a document 14, radiation from the sources 12,13 will be reflected by the reflector 20 onto the detector(s) 16. In addition, radiation passing through the document will be reflected back through the document to the detector(s) 16.

The sources 12,13 are arranged such that light will be reflected/scattered from the surface of the document 14 back to the detector(s) 16. No direct light path exists between the illumination sources and the detector(s). Dependant upon the choice of detector 16, the illumination sources 12,13 can either be broad band polychromatic devices, generating illumination from the IR and visible band (eg fluorescent tubes with appropriate coatings) or, can be collections of monochromatic sources (eg LEDs) that are modulated to provide pulses of light spread across the IR and visible spectra.

The detector(s) 16 could be a set of narrow band detectors for detecting radiation in respective wavebands, or a broadband receiver. In the latter case, the sources 12,13 will need to be modulated on and off to ensure that only one frequency or frequency band of light is illuminating the note at any one time. The modulation would be controlled from a processor or a piece of hardware



that would successively turn on each illumination source whilst turning off each of the others.

The transmissive, visible radiation source 5 is positioned such that it is directly opposite the  
5 detector(s) 16. The transmissive source 5 can either be monochromatic or polychromatic to match the form of detector 16 but does not need to have any output in the IR.

The relative brightnesses of the sources 12,13 and the source 5 are arranged such that the image received by the  
10 detector(s) 16, when a document is present, is primarily created from the light reflected from the document, thus creating visible and IR reflective images of the document. The transmissive source 5 does not provide any substantial contribution to the received light when a document is  
15 present. However, when no document is present the transmissive source is set to be brighter than any reflected image.

Although two sources 12,13 are shown in Figures 1A and 1B, the invention is also applicable to one or more than  
20 two sources.

The detector(s) 16 shown in Figure 1 receive the light from all three illumination sources 5,12,13 in all spectra. The detector(s) is chosen to match the form of illumination and can either be a single broadband device for use with  
25 modulated monochromatic sources, or a collection of narrow band devices responsive to selected spectra for use with polychromatic sources, the latter arrangement being achievable via the use of filters in front of the detectors. Typically the detectors will be photo-diodes or  
30 photo-transistors.

The use of polychromatic sources requires one detector for each point in the spectrum of interest e.g. red, green, blue and IR for colour and IR imaging, or visible and IR for grey scale and IR imaging.

35 The use of multiple modulated illumination sources 5,12,13 allows the use of a single broadband detector as mentioned above.

The spectra in the example above is not meant to convey any limit to the range of usable spectra, the device can be constructed to work in any areas of the electro-magnetic spectrum providing suitable illumination sources and receptors are available.

Before a document arrives at the detector system 3 (Figure 1A) the transmissive source 5 will be illuminating the detector(s) 16 creating a constant bright image in the visible domain. The arrival of the document 14 will interrupt this beam creating a trigger indicating the arrival of its leading edge. Thereafter, with the document 14 present the detector(s) 16 will receive light from the reflective sources 12,13 until either a hole in the document occurs in front of the detector or the trailing edge arrives. Both events will lead to the light level at the detector rising back to the "no document" level.

Figure 2 shows an illustration of the signal being received at a given receptor pixel as the document moves passed the detector.

The image thus created across all pixels of the detector is therefore one that has a very bright (or even saturated) background (from the transmissive illumination) within which is a reflective image of the document. The reflective image contains bright (or saturated) regions created by the transmissive illumination shining through any holes in the document. An illustration of this is shown in Figure 3.

Further, it is important to realise that the detector head will be creating multiple images of each document, one for each illumination or reception spectra. The minimum for a gray scale and IR device will thus be two images and for a red, green, blue, IR device four images will be created. The number of images being equal to the number of points in the spectrum being used.

The or each detector element within the detector(s) 16 generates an analogue signal which is fed to the A/D convertor 6 for conversion into digital form, the digital

signals then being fed to the microprocessor 7. The microprocessor 7 stores the digital signals in a conventional manner so as to define an image for each of the received wavebands.

5 Each image created by the detector(s) 16 can be either separately processed or processed in conjunction with other images. A typical process sequence for a grey scale and IR device is shown in Figure 4.

10 The incoming stream is the raw data arriving from the detector head and is initially segregated 30 to form images 31,32 for each point in the spectrum.

15 After this, visible image 32 is processed 33 in a conventional manner to determine the skew, this process also involving finding the edges of the document. The skew and positional information is then used 34 to de-skew and position all images such that they have a common co-ordination system with the templates that are used later in the processing 35,36.

20 The de-skewed visible image 36 is then processed 37 in order to determine its classification 43 by reference to predetermined templates 39 stored in a store 40. This comprises the denomination (the face value for a banknote) the face, (the top or bottom image) and the orientation (which way up the document is). A double sided document, 25 such as a banknote, has one denomination, two faces and two orientations, a total of four classes. The determination of this is usually carried out on a normalised image 38 that has had the contrast varying effects of wear and print variations removed. The recognition means applied to the 30 document, such as double threshold correlation using templates 48 are well known and will not be disussed here since the choice of algorithm will depend upon many factors such as image resolution and whether or not the image is from all or part of the document. A typical example is the 35 technique used on the De La Rue 2700 Banknote Counter.

Once the document classification has been determined, this is then used to inform and reduce the processing

requirements remaining. It should also be noted that whilst the processing up to this point has been of a serial nature the remaining processing can be carried out either serially or in parallel depending upon the choice of processing environment.

5 The authentication process 42 is carried out on the de-skewed IR image 35 and is essentially a comparison between the acquired image and a single template 41 stored in the store 40, for the class 43 of document being examined. The single template 41 is the one indicated by the classification of the visible image. The use of the visible classification 43 to select the template 41 significantly reduces the processing required and allows features that may not distinguish two different classes to still be useful in the authentication decision. The simultaneous existence of the visible and IR images will also allow verification that a feature found in the IR domain for authentication also exists in the appropriate form in the visible domain. A version of this device that produces colour images may also be able to check the colour of the specific features. An example of an authenticatable feature is a portrait where the printing inks are arranged such that they appear to be a single colour when viewed in visible light but when viewed in the infra-red split into reflective and absorbing blocks.

25 The remaining processes 44 establish the condition (fitness) of the document and take place on the visible image 36. It should be noted that all of the processes for condition detection are performed on an image that has not been normalised.

30 The establishment of the transmissive illumination to be such that all holes 21 etc within the document become bright spots (brighter than the reflective image could ever reach) provides a means by which all such defects in the document can be determined using a suitable threshold. (See Figure 2). Such information can be obtained by simple search through the image for data values that are as bright

as the background. This process is again informed from the class 43 of the document since a template 45 is required to mask out transparent windows that may occur in some documents (e.g. Australian banknotes).

5 Similarly the use of edge tracing algorithms can be applied to the image to establish the position and size of any folds around the document edges. These algorithms establish the line equations for each portion of the document edge and then establish the intersection point of  
10 each line. The folds can be found by checking for orthogonality of the lines and by aligning the image within the appropriate rectangle for the document as informed by its class.

It is well known that as a document (especially a  
15 banknote) is handled the dirt build up tends to evenly cover it making the white areas less white and the dark areas less dark, in other words the overall contrast of the image is reduced. The level of dirt on the document (Soil level) is also determined from the visible image 36 and  
20 achieves this by a two pass process on the image. Again the process 46 is informed from the already established classification 43. The first pass is an overall comparison of the image with its template 48 for variations in the contrast of the image. This will give an overall measure  
25 and will also detect any large stains that may be present. The second pass uses the appropriate template 47 to just examine the unprinted areas of the document to determine its absolute brightness relative to its template. The template will have been developed from a mint note. The  
30 combination of these two measures will be used to report the overall soil level.

The templates 41,47,48 will typically be discriminant functions as used in the De La Rue 2700 Banknote Counter. The IR templates would be a binary image of the note face  
35 showing the areas containing the controlled IR features. The soil templates would be grey scale image of the note

showing the contrast levels of a clean bank note. It would particularly illustrate areas of un-printed paper.

CLAIMS

1. A method of inspecting documents of value, the method comprising:
- 5 a) obtaining images of one or more parts of the document from radiation received from that part or those parts of the document in respective different wavelength bands;
- 10 b) performing an analysis of one of said images to identify a first type of class within which the document of value is included; and
- 15 c) performing an analysis of another of said images using corresponding predetermined data relating to members of the first type of class identified in step b) so as to determine a second type of class within which the document of value is included.
2. A method according to claim 1, wherein the analyses of steps b) and c) comprise comparing the corresponding image
- 20 with one or more predetermined images and selecting the predetermined image defining the best match.
3. A method according to claim 1 or claim 2, wherein the first type of class defines one or more of the denomination, face and orientation of the document of
- 25 value.
4. A method according to any of claims 1 to 3, wherein the image used in step b) is obtained from visible radiation received from the document.
5. A method according to any of claims 1 to 4, wherein
- 30 the second type of class defines the authenticity of the document of value.
6. A method according to any of claims 1 to 5, wherein the image used in step c) is defined by radiation received from the document in a waveband outside the visible
- 35 wavelength range, for example the infrared wavelength range.

7. A method according to any of claims 1 to 4, wherein the second type of class defines the degree of soiling of the document of value.

8. A method according to any of claims 1 to 7, further comprising:

5 d) performing an analysis of one of said images using corresponding predetermined data relating to members of the first type of class identified in step b) so as to determine a third type of class within which the document of value is included.

9. A method according to claim 8, wherein the third type of class defines one or more the degree of soiling, holes and tears of the document of value.

10. A method according to any of claims 7 to 9, wherein the image is obtained from radiation in the visible wavelength range.

11. A method according to any of the preceding claims, wherein the document of value comprises a banknote.

12. A method according to any of the preceding claims, wherein step (a) is performed using a document monitoring system comprising illumination apparatus for illuminating a region, at which part of a document is located in use, with radiation in at least two different wavelength bands; and detection apparatus for detecting any of said radiation which is reflected by or transmitted through substantially the same said part of the document and for generating corresponding output signals.

13. A method according to claim 12, wherein the illumination apparatus generates the radiation at the at least two different wavelength bands simultaneously, the detection apparatus having separate detectors responsive to radiation in the different wavelength bands.

14. A method according to claim 12 or claim 13, wherein the illumination apparatus generates radiation in the different wavelength bands sequentially, the detection



apparatus having one or more detectors responsive to radiation in all the wavelength bands.

15. A method according to any of claims 12 to 14, wherein the illumination apparatus comprises at least one radiation source located on the same side of the region as the detection apparatus.

16. A method according to any of claims 12 to 15, wherein the illumination apparatus includes a radiation source located on the opposite side of the region to the detection apparatus for transmitting radiation through the document.

17. A method according to claim 16, when dependent on claim 15, wherein the intensity of the radiation generated by the source on the opposite side of the region to the detection apparatus is greater than the intensity of the radiation generated by the other source(s).

18. A method according to any of claims 12 to 15, wherein the illumination apparatus includes a reflective surface in the said region and on which a document is located in use, wherein any radiation impinging on the reflective surface is reflected towards the detection apparatus.

19. A method according to any of claims 12 to 18, wherein the detection apparatus comprises one or more photodiodes or phototransistors.

20. A method according to any of claims 12 to 19, wherein the illumination apparatus comprises one or more fluorescent tubes or light emitting diodes.

21. A method according to any of claims 12 to 20, wherein the wavelength bands define radiation in the visible and infrared regions respectively.

22. A method according to any of claims 12 to 21, further comprising more than one set of said illumination apparatus and detection apparatus, each set defining a respective region, wherein in use a document can be positioned so that respective parts of the document are located in each of the said regions.

23. A method according to any of claims 12 to 22, further comprising means for moving a document through the or each region.

24. A method according to claim 23, wherein the or at  
5 least one of the regions extends across the full dimension of the document transverse to the feed direction.

Fig.1a.

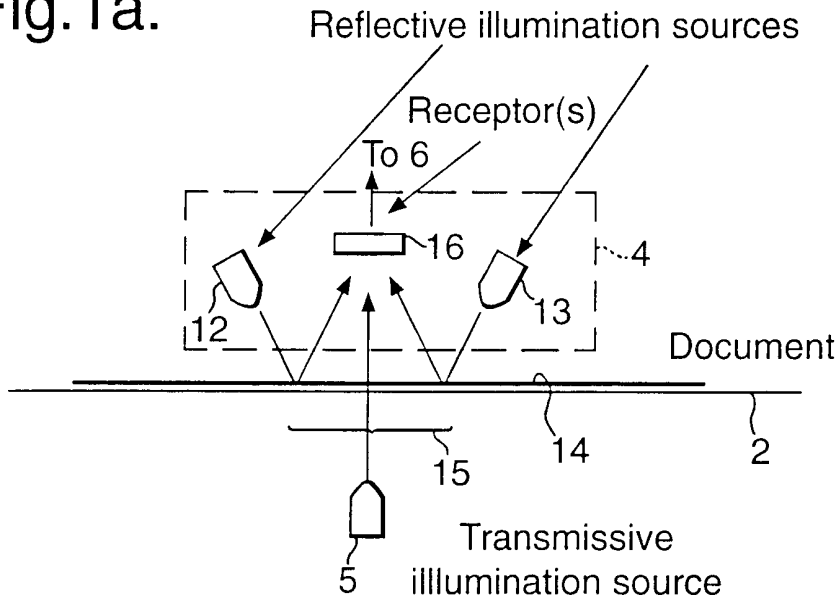

Fig.1b.

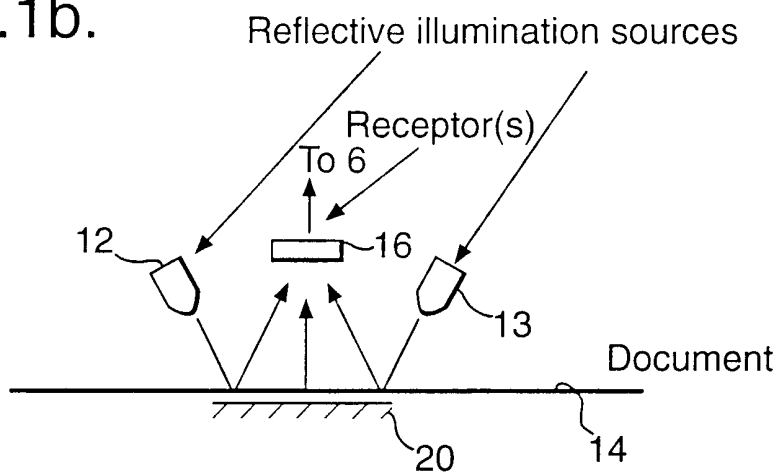

Fig.2.

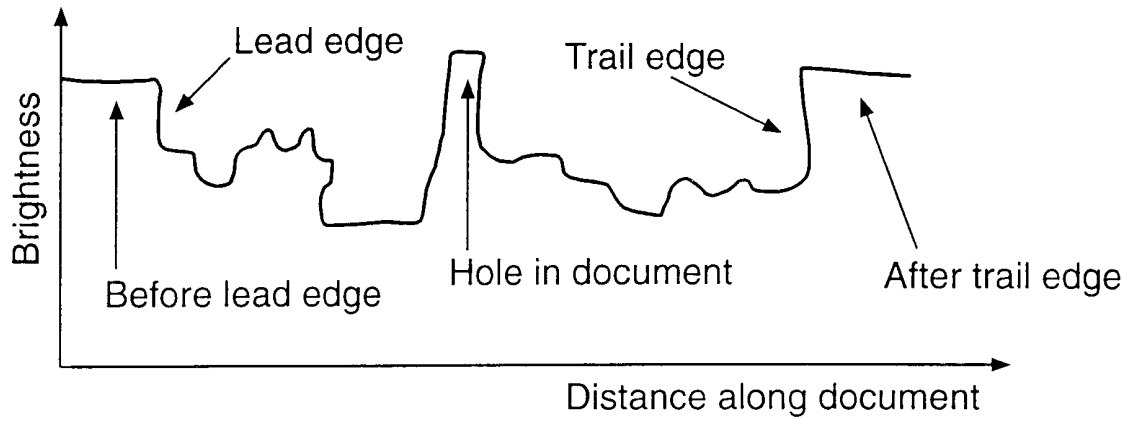

Fig.3.

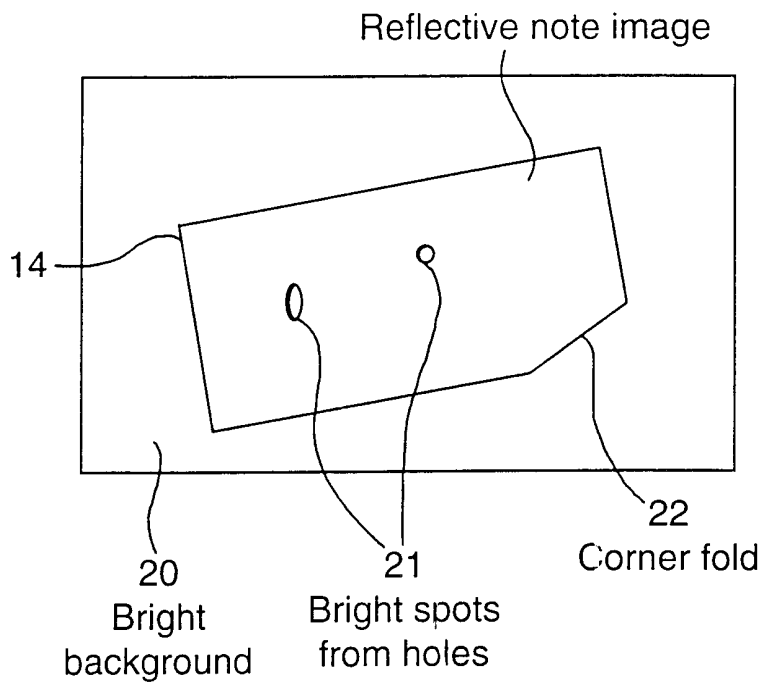

Fig.4.

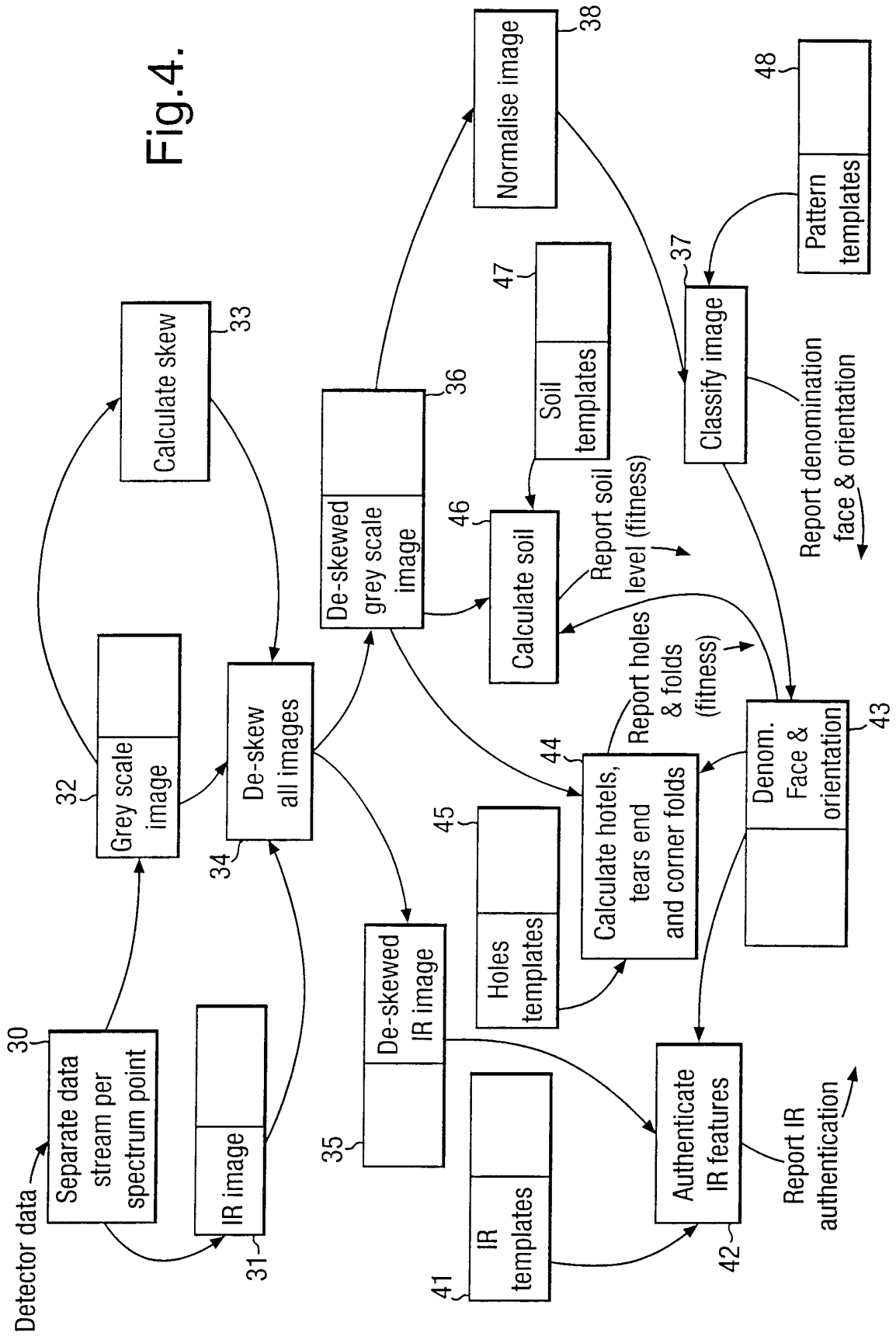
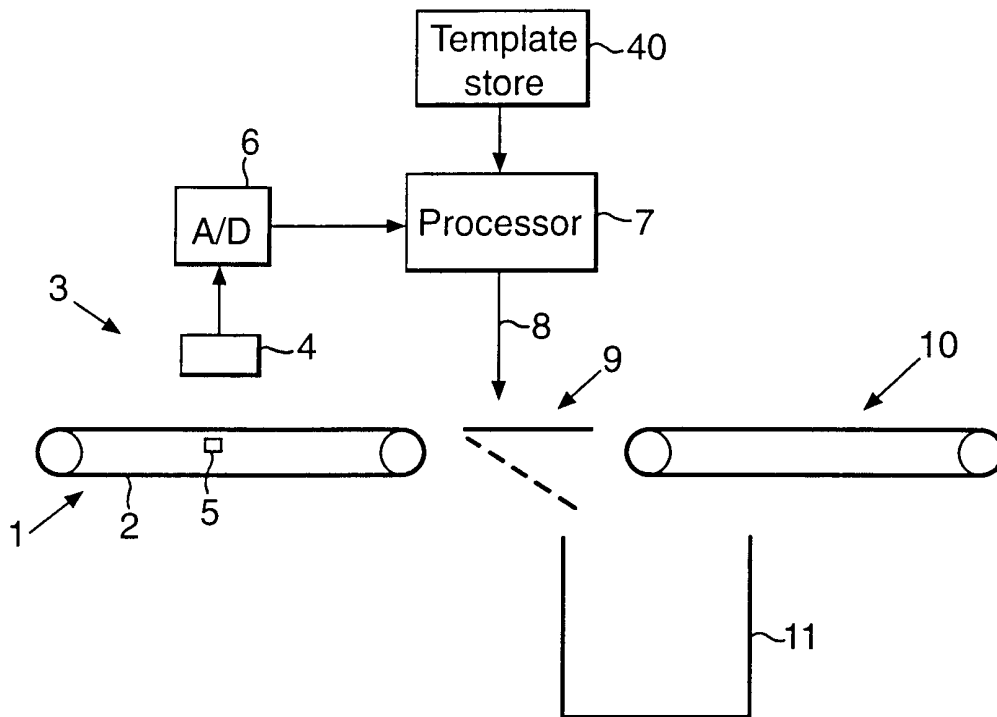

Fig.5.



# INTERNATIONAL SEARCH REPORT

International Application No

PCT/GB 01/00254

**A. CLASSIFICATION OF SUBJECT MATTER**  
 IPC 7 G07D7/12 G07D7/18

According to International Patent Classification (IPC) or to both national classification and IPC

**B. FIELDS SEARCHED**

Minimum documentation searched (classification system followed by classification symbols)

IPC 7 G07D

Documentation searched other than minimum documentation to the extent that such documents are included in the fields searched

Electronic data base consulted during the international search (name of data base and, where practical, search terms used)

EPO-Internal

**C. DOCUMENTS CONSIDERED TO BE RELEVANT**

Category *	Citation of document, with indication, where appropriate, of the relevant passages	Relevant to claim No.
A	EP 0 660 277 A (AZKOYEN IND SA) 28 June 1995 (1995-06-28) cited in the application  page 3, line 30 - line 49 page 4, line 12 - line 35 page 7, line 54 -page 8, line 47 figure 1	1,2,11, 12, 14-16, 21,23,24
E	DE 198 40 482 A (GIESECKE & DEVRIENT GMBH) 9 March 2000 (2000-03-09)  column 3, line 32 -column 4, line 64 column 5, line 5 -column 6, line 27 column 8, line 8 - line 39 column 9, line 20 -column 10, line 8 figure 1	1,2,5-7, 10-13, 15,16, 20-23

Further documents are listed in the continuation of box C.

Patent family members are listed in annex.

\* Special categories of cited documents :

- \*A\* document defining the general state of the art which is not considered to be of particular relevance
- \*E\* earlier document but published on or after the international filing date
- \*L\* document which may throw doubts on priority claim(s) or which is cited to establish the publication date of another citation or other special reason (as specified)
- \*O\* document referring to an oral disclosure, use, exhibition or other means
- \*P\* document published prior to the international filing date but later than the priority date claimed

- \*T\* later document published after the international filing date or priority date and not in conflict with the application but cited to understand the principle or theory underlying the invention
- \*X\* document of particular relevance; the claimed invention cannot be considered novel or cannot be considered to involve an inventive step when the document is taken alone
- \*Y\* document of particular relevance; the claimed invention cannot be considered to involve an inventive step when the document is combined with one or more other such documents, such combination being obvious to a person skilled in the art.
- \*&\* document member of the same patent family

Date of the actual completion of the international search

14 June 2001

Date of mailing of the international search report

22/06/2001

Name and mailing address of the ISA  
 European Patent Office, P.B. 5818 Patentlaan 2  
 NL - 2280 HV Rijswijk  
 Tel. (+31-70) 340-2040, Tx. 31 651 epo nl,  
 Fax: (+31-70) 340-3016

Authorized officer

Bocage, S

# INTERNATIONAL SEARCH REPORT

International Application No

PCT/GB 01/00254

**C.(Continuation) DOCUMENTS CONSIDERED TO BE RELEVANT**

Category °	Citation of document, with indication, where appropriate, of the relevant passages	Relevant to claim No.
A	US 5 498 879 A (DE MAN IVO) 12 March 1996 (1996-03-12)  column 2, line 55 -column 7, line 54 figures 1,2  ---	12, 14-16, 19-24
A	WO 85 02928 A (BERGSTROEM ARNE) 4 July 1985 (1985-07-04) page 5, line 9 -page 9, line 11  ---	12-15, 20,21
A	GB 2 107 911 A (CUBIC WESTERN DATA) 5 May 1983 (1983-05-05) cited in the application page 2, line 60 -page 4, line 24 figures 3,6  ---	1,2,5-7, 11-16, 18-24
A	US 3 679 314 A (MUSTERT RUDOLF) 25 July 1972 (1972-07-25) column 2, line 47 - line 62 claims  ---	12
A	US 4 723 072 A (NARUSE KAZUAKI) 2 February 1988 (1988-02-02)  ---	
A	WO 99 09382 A (POTTER MICHAEL ;RUE DE INT LTD (GB)) 25 February 1999 (1999-02-25)  -----	



# INTERNATIONAL SEARCH REPORT

Information on patent family members

International Application No

PCT/GB 01/00254

Patent document cited in search report	A	Publication date	Patent family member(s)	Publication date
EP 0660277	A	28-06-1995	ES 2077529 A	16-11-1995
			AT 176068 T	15-02-1999
			DE 69416098 D	04-03-1999
			DE 69416098 T	05-08-1999
			DK 660277 T	13-09-1999
			GR 3029993 T	30-07-1999
			SI 660277 T	30-06-1999
DE 19840482	A	09-03-2000	AU 5736399 A	27-03-2000
			WO 0014689 A	16-03-2000
US 5498879	A	12-03-1996	DE 59208542 D	03-07-1997
			EP 0537431 A	21-04-1993
			ES 2103330 T	16-09-1997
			FI 924620 A	15-04-1993
			HK 1007019 A	26-03-1999
			JP 5282432 A	29-10-1993
			NO 923966 A	15-04-1993
			US 5304813 A	19-04-1994
WO 8502928	A	04-07-1985	AT 36766 T	15-09-1988
			EP 0198819 A	29-10-1986
			FI 862714 A, B,	25-06-1986
GB 2107911	A	05-05-1983	AU 556102 B	23-10-1986
			AU 8884582 A	28-04-1983
			CA 1177172 A	30-10-1984
			HK 29586 A	02-05-1986
			US 4587434 A	06-05-1986
US 3679314	A	25-07-1972	CH 484479 A	15-01-1970
			DE 2007903 A	07-01-1971
			FR 2049853 A	26-03-1971
			GB 1248019 A	29-09-1971
			NL 7002966 A, B	15-12-1970
			SE 354536 B	12-03-1973
			ZA 7003541 A	27-01-1971
US 4723072	A	02-02-1988	JP 60146386 A	02-08-1985
			JP 60146388 A	02-08-1985
			JP 60164886 A	27-08-1985
			JP 1961137 C	10-08-1995
			JP 6090749 B	14-11-1994
			JP 60164237 A	27-08-1985
			DE 3500650 A	18-07-1985
			DE 3546508 C	24-11-1988
			GB 2153070 A, B	14-08-1985
			KR 8902004 B	07-06-1989
			US 4737649 A	12-04-1988
WO 9909382	A	25-02-1999	AU 8122698 A	08-03-1999
			CN 1266485 T	13-09-2000
			EP 1004006 A	31-05-2000
			US 6024202 A	15-02-2000