

H. MACDONALD.
 MATCH DISPENSING DEVICE.
 APPLICATION FILED JUNE 17, 1910.

996,779.

Patented July 4, 1911.

2 SHEETS-SHEET 1.

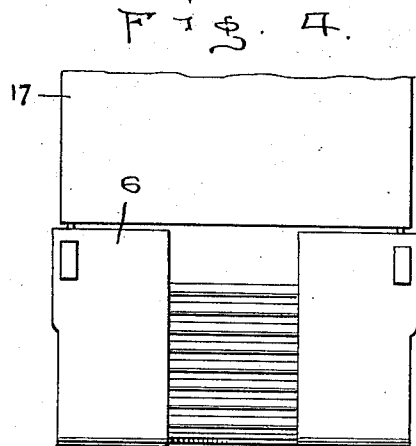
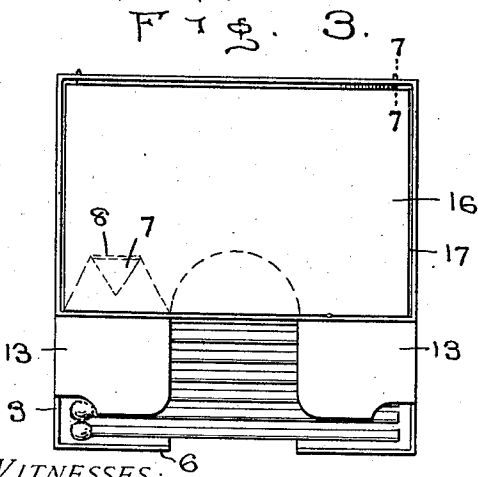
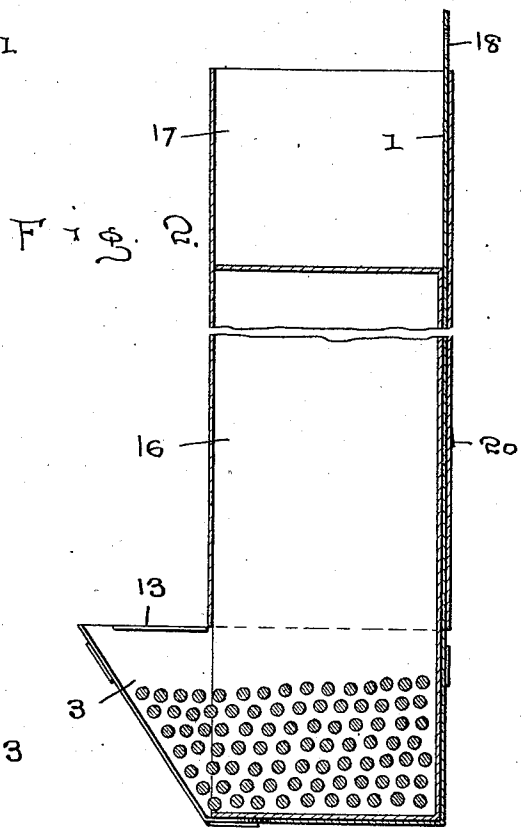
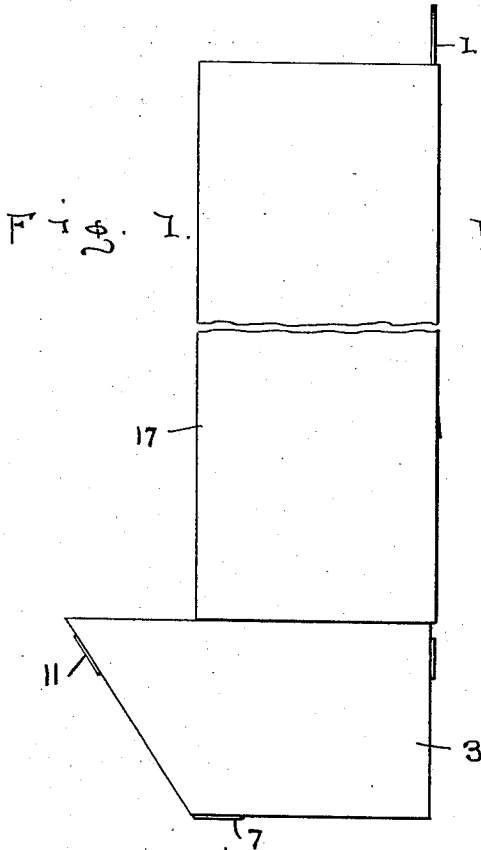

WITNESSES:
Thos. Riley
M. Newcomb.

INVENTOR
H. Macdonald
 BY
W. J. FitzGerald & Co.
 Attorneys

H. MACDONALD,
MATCH DISPENSING DEVICE.
APPLICATION FILED JUNE 17, 1910.

996,779.

Patented July 4, 1911.

2 SHEETS—SHEET 2.

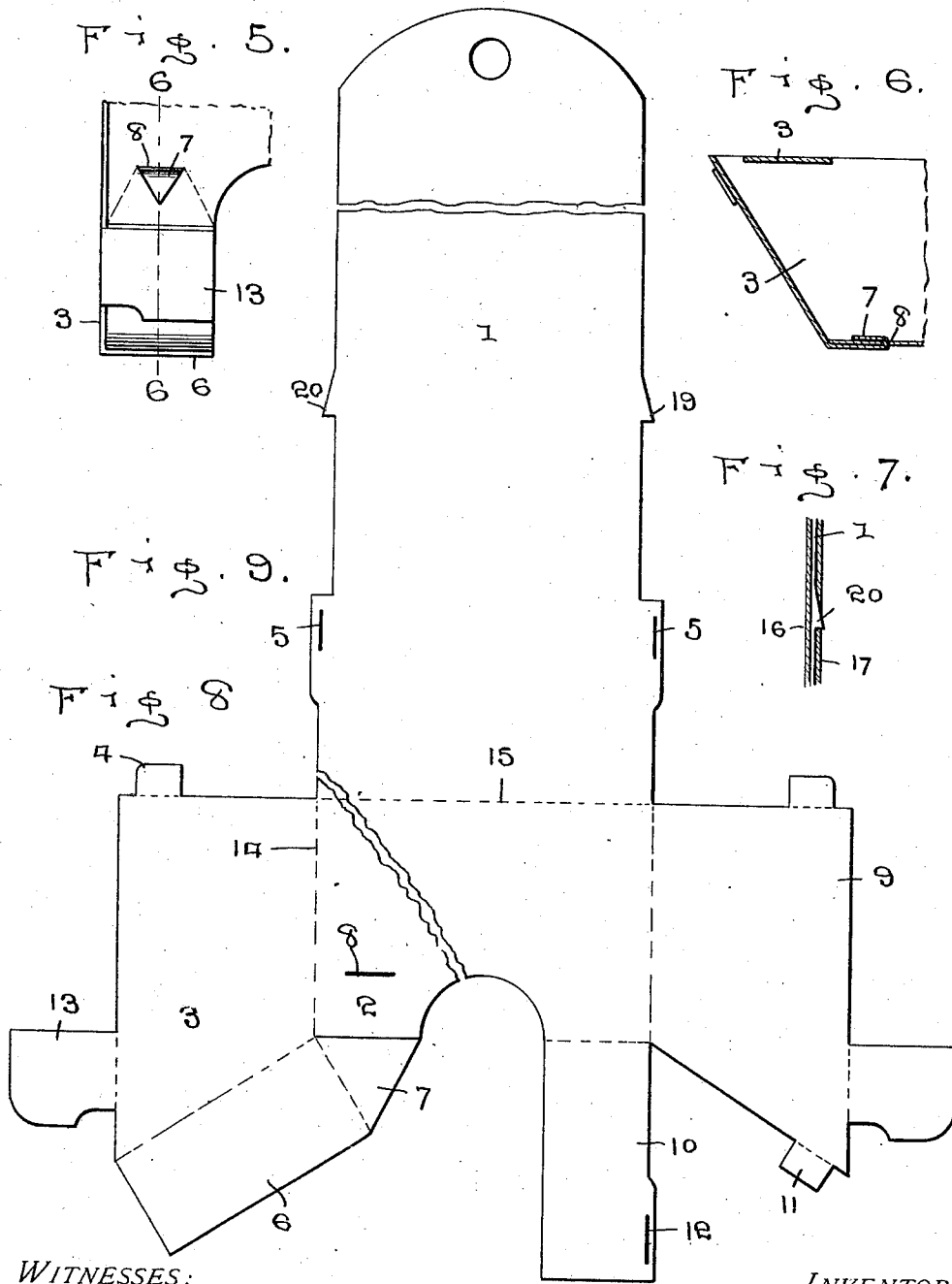

WITNESSES:

Thomas Riley
M. Newcomb

INVENTOR

H. Macdonald

BY *W. J. Fitzgerald & Co.*
Attorneys

UNITED STATES PATENT OFFICE.

HUGH MACDONALD, OF ANN ARBOR, MICHIGAN.

MATCH-DISPENSING DEVICE.

996,779.

Specification of Letters Patent.

Patented July 4, 1911.

Application filed June 17, 1910. Serial No. 567,461.

To all whom it may concern:

Be it known that I, HUGH MACDONALD, a citizen of the United States, residing at Ann Arbor, in the county of Washtenaw and State of Michigan, have invented certain new and useful Improvements in Match-Dispensing Devices; and I do hereby declare the following to be a full, clear, and exact description of the invention, such as will enable others skilled in the art to which it appertains to make and use the same.

My invention relates to new and useful improvements in match dispensing devices and my object is to provide a device which is adapted to be attached to the usual form of match box.

A further object is to provide means whereby the matches will be fed by gravity into the dispensing device.

A further object is to provide means for preventing the matches from being removed in greater numbers than one at a time, and, a further object is to provide means for readily assembling the parts of the dispensing device.

Other objects and advantages will be hereinafter referred to and more particularly pointed out in the specification and claim.

In the accompanying drawings which are made a part of this application, Figure 1 is a side elevation of a match box showing my improved device attached thereto. Fig. 2 is a transverse vertical sectional view thereof. Fig. 3 is a top plan view of the box and dispensing device. Fig. 4 is a detail front elevation thereof. Fig. 5 is a detail top plan view of the dispensing device. Fig. 6 is a sectional view as seen on line 6—6 Fig. 5. Fig. 7 is a detail sectional view as seen on line 7—7 Fig. 3. Fig. 8 is a fragmentary view of the blank employed for forming that part of the dispensing device shown in Fig. 5, and, Fig. 9 is a plan view of a blank showing a different design of parts of the dispensing device.

Referring to the drawings in which similar reference numerals designate corresponding parts throughout the several views, 1 indicates the body portion of the dispensing device, which is preferably oblong in shape and constructed of a flat piece of material, the lower end of which is to be extended horizontally to form the bottom 2, said bottom section having at its outer edges integral flanges, which form the side walls 3 of the dispensing device, when said flanges

are bent upwardly and at right angles to the bottom section. The rear edges of the side walls 3 are provided with tongues 4, which are adapted to extend through slits 5 in the body 1 and when the tongues are entered through the slits and then bent over on to the back of the body, the side walls will be securely held in their adjusted positions.

In order to prevent the matches from casually leaving the holding device, the forward edges of the side walls are extended at an angle and have formed integral therewith guides 6, the lower ends 7 of the guides being substantially dart-shaped, so that when the side walls are folded upwardly, the tapered ends of the guides will pass below the bottom 2. The pointed ends are then introduced through slots 8 in the bottom 2 and the portions projecting through said slots bent downwardly so as to lie flat upon the upper surface of the bottom wall. Instead, however, of forming the guides integral with the side walls, as shown in Fig. 8, they may be formed separately, as shown in Fig. 9, the forward edge of the side wall 9 being tapered to receive the guide 10, which guide is formed integral with the forward edge of the bottom wall 2 and in order to secure the guide to the side wall, the tapered edge of the side wall is provided with a tongue 11, which extends through a slot 12 in the guide 10 and by bending said tongue parallel with the outer face of the guide after it has been introduced through the slot, the guide will be securely held in engagement with the side wall. The side walls of either form are provided with integral guards 13, which are adapted to be folded over the opening of the inclined portion of the dispensing device, said guards serving to prevent the matches from being removed in greater numbers than one at a time, that portion of the guards adjacent their connection with the side walls being cut away to permit the head of the match to pass between the guide and guard without frictional engagement with either.

In assembling the dispensing device, the side walls 3 are folded along the dotted line 14 until they assume a vertical position or at right angles to the bottom section 2, when the bottom section is folded along the dotted line 15 until it is at right angles to the body 1, when by entering the tongues 4 through the slits 5 and then bending the projecting

ends of the tongues over the rear face of the body, the side walls and bottom will be held in their proper positions.

If that form of blank shown in Fig. 8 is used, the pointed end 7 of the guide is introduced through the slit 8 and secured by bending the same, while if that form of blank shown in Fig. 9 is used, the tongue 11 is introduced through the slot 12 and secured thereto by bending the tongue. The guards 13 are then bent inwardly and over the opening formed by the inclined guides, thus limiting the number of matches to be removed at a time from the receptacle. The body 1 is then introduced between the box proper 16 and its covering 17, the box and covering being constructed in the usual manner. The body 1 is of sufficient length to project entirely through the covering and is provided at its free end with an opening 18, through which any suitable form of object may be introduced to suspend the box and dispensing receptacle. The lower edge of the covering 17 rests upon the upper edges of the side walls 3, while the box proper is moved downwardly until the lower end thereof rests upon the bottom 2, so that the matches in the box may feed by gravity into the inclined portion of the receptacle and by spacing the guides 6 a distance apart, the finger and thumb may be readily introduced to remove the matches. By lowering the box in the manner shown, a space is left at the upper end of the covering, into which the burned matches may be deposited, if desired, the upper end of the box 16 forming the bottom wall of the compartment.

In placing the dispensing receptacle in engagement with the match box, the box proper is removed from its covering and the body 1 passed through the covering, after which the box is returned into the covering and moved into engagement with the bottom wall 2 and to positively lock the body in engagement with the covering, said body may be provided with a pair of prongs 19, which are entered through incisions 20 in

the covering and as the lower ends of the prongs are provided with shoulders, it will be readily seen that the covering will be prevented from leaving the body 1 until the box 16 has been removed therefrom, when the body may be moved outwardly until the prongs are released and said body then removed from the covering.

As the receptacle is removable from the match box, it will be readily seen that it can be repeatedly used until worn out or otherwise destroyed and can readily be attached to the different match boxes. It will likewise be seen that the dispensing device can be shipped in blank form and afterward folded together, if desired, thus occupying but a minimum amount of space for shipping and storing the same. It will further be seen that the dispensing device may be formed of aluminum or similar flexible metals or may be constructed of cardboard, if desired.

What I claim is:—

A dispensing receptacle formed from a single piece of material comprising a body portion, a bottom portion formed integral with said body portion and bent at right angles thereto, side portions formed integral with said bottom and adapted to be bent at right angles thereto, tongues formed on the rear edges of said side portions, said body portion being provided with slits to receive said tongues, guides on the forward end of said bottom portion, connecting means between said guides and side walls, and guards formed integral with said side walls and adapted to be bent at right angles thereto and cooperate with said guides to limit the removal of the contents of said receptacle.

In testimony whereof I have signed my name to this specification in the presence of two subscribing witnesses.

HUGH MACDONALD.

Witnesses:

L. A. TOWSELEY,
V. E. VAN AMERINGEN.