

May 9, 1950

E. A. ROBINETTE

2,506,841

OIL BURNER

Filed June 11, 1946

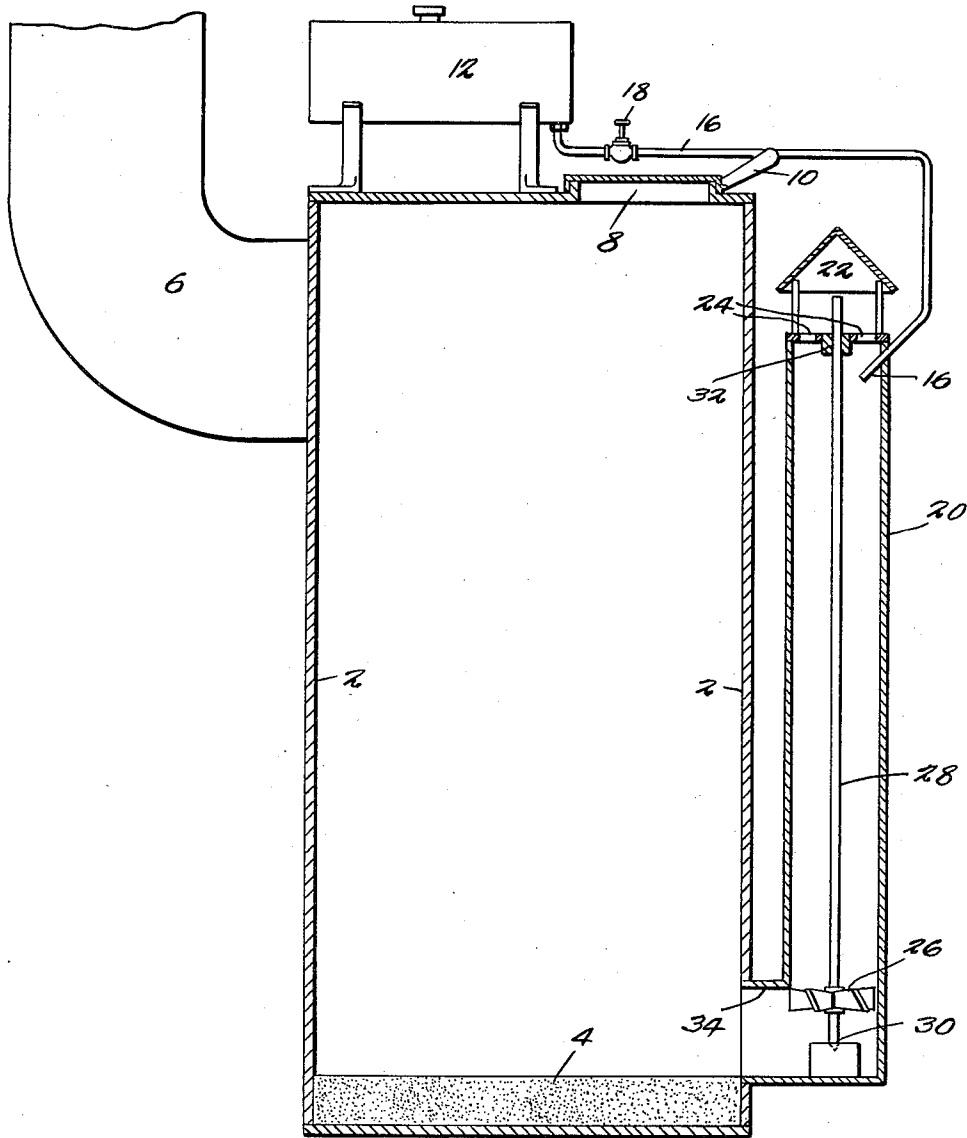

Inventor

*E. A. Robinette*

By *C. A. Knowlton*

Attorneys

# UNITED STATES PATENT OFFICE

2,506,841

## OIL BURNER

Ernest A. Robinette, Carrollton, Mo.

Application June 11, 1946, Serial No. 675,908

1 Claim. (Cl. 126-93)

1

My present invention relates to an improved oil burner and particularly to a self vaporizing burner adapted to operate on crank case oil, fuel oil, or kerosene, and in which the vaporizing means including a fan, is operated by the draft through the combustion chamber.

In the accompanying drawings I have illustrated one complete example of the physical embodiment of my invention according to the best mode I have thus far devised but it will be understood that various changes and alterations may be made in the exemplified structure within the scope of the appended claim.

In the drawings, the single figure is a vertical sectional view through the furnace of my invention showing the draft operated vaporizer for the fuel.

Referring now to the drawings in detail I have illustrated the oil burner of my invention as embodying a combustion chamber 2 provided with a relatively thick layer of sand 4 on the bottom thereof. An exhaust stack is indicated at 6, and a cover 8 having a handle 10 is hinged mounted on the top of the chamber.

The oil tank 12 is mounted above the chamber to provide gravity feed through the pipe 16 and a valve 18 in the pipe permits control of the flow of oil. In this embodiment of my invention any combustible liquid fuel may be employed including crank case oil from automobiles.

The lower outlet end of the pipe 16 is located within the fuel and air intake tube 20 and near its upper end. A cover 22 for the tube protects from the weather the air ports 24 in the tube. At the lower end of the tube I utilize a fan 26 mounted on the shaft 28 which is journaled at its lower end at 30 and its upper end at 32, and a laterally extended communicating tube 34 provides for the admission of vaporized fuel from the fuel and air intake tube to the combustion chamber. The fan is disposed below the plane of the uppermost portion of the inlet for said fuel into the combustion chamber, and thus the blades of the fan feed said fuel laterally through the inlet.

In operation, the fuel pipe valve is turned to open position, and the cover 8 is raised and a lighted wad of paper or other suitable material is inserted therein to create a draft through the fuel and air intake tube, the chamber, and through the stack. The draft thus created will rotate the vaporizing fan and as the fuel drops from the pipe 16 onto the fan blades the fuel will be vaporized and drawn into the chamber to be

2

initially ignited from the lighted wad. Once the draft is created and the initial charge of fuel is ignited, the process will continue as long as fuel is fed to the vaporizer.

From the above description it will be apparent that an economical and efficient burner is presented which is especially adaptable for use in heating chicken brooder houses, barns and the like.

Having thus fully described my invention what I claim as new and desire to secure by Letters Patent is:

A fuel oil burner comprising a combustion chamber, an exhaust stack at the upper end of the chamber, there being an inlet for air and vaporized oil in the lower portion of the side wall of the chamber, a vertically disposed fuel and air intake tube of substantially smaller diameter than the diameter of the exhaust stack mounted outside and to one side of the chamber, a horizontal communicating tube extending between said inlet and the lower end of the fuel and air intake tube, the fuel and air intake tube having air intake ports at its upper end, means for admitting oil in the upper part of said tube in controlled amounts, and a draft impelled fan mounted within the horizontal communicating tube and extending across the lower end of the fuel and air intake tube, said fan being of substantially the same diameter as the vertical tube and being aligned coaxially therewith so as to be in the path of all the air and oil passing through the fuel and air intake tube, said fan being disposed below the plane of the upper portion of the combustion chamber inlet, whereby vaporized oil and air are drawn in a substantially horizontal plane through said inlet and into the combustion chamber.

ERNEST A. ROBINETTE.

### REFERENCES CITED

The following references are of record in the file of this patent:

#### UNITED STATES PATENTS

Number	Name	Date
434,810	Rogers	Aug. 19, 1890
940,713	Newman	Nov. 23, 1909
1,387,799	Mills	Aug. 16, 1921
1,387,800	Mills	Aug. 16, 1921
1,948,662	Holthans	Feb. 27, 1934
2,165,162	Thornton	July 4, 1939
2,228,324	Norton	Jan. 14, 1941