

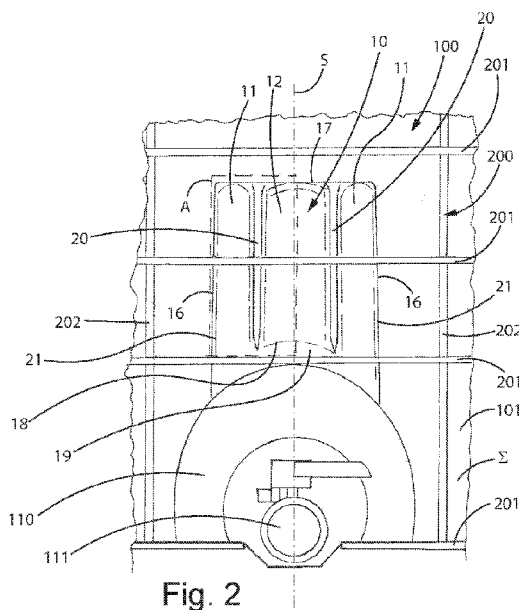

- (51) International Patent Classification:  
B65D 77/04 (2006.01)
- (21) International Application Number:  
PCT/IB2024/055569
- (22) International Filing Date:  
07 June 2024 (07.06.2024)
- (25) Filing Language: Italian
- (26) Publication Language: English
- (30) Priority Data:  
102023000011772 08 June 2023 (08.06.2023) IT
- (71) Applicant: MASCHIO N.S. S.R.L. [IT/IT]; Via Umbria  
SN, 20056 Grezzago (MI) (IT).
- (72) Inventor: MASCHIO, Pietro; Via Unione Europa, 10,  
20060 Pozzo d'Adda (MI) (IT).
- (74) Agent: BRANCA, Emanuela; c/o Barzanò & Zanardo Mi-  
lano S.p.A., Via Borgonuovo, 10, 20121 Milano (IT).
- (81) Designated States (unless otherwise indicated, for every  
kind of national protection available): AE, AG, AL, AM,  
AO, AT, AU, AZ, BA, BB, BG, BH, BN, BR, BW, BY, BZ,  
CA, CH, CL, CN, CO, CR, CU, CV, CZ, DE, DJ, DK, DM,  
DO, DZ, EC, EE, EG, ES, FI, GB, GD, GE, GH, GM, GT,  
HN, HR, HU, ID, IL, IN, IQ, IR, IS, IT, JM, JO, JP, KE, KG,  
KH, KN, KP, KR, KW, KZ, LA, LC, LK, LR, LS, LU, LY,  
MA, MD, MG, MK, MN, MU, MW, MX, MY, MZ, NA,  
NG, NI, NO, NZ, OM, PA, PE, PG, PH, PL, PT, QA, RO,  
RS, RU, RW, SA, SC, SD, SE, SG, SK, SL, ST, SV, SY, TH,  
TJ, TM, TN, TR, TT, TZ, UA, UG, US, UZ, VC, VN, WS,  
ZA, ZM, ZW.

(54) Title: REINFORCED TANK FOR TRANSPORTING AND STORAGE OF LIQUIDS



(57) Abstract: Tank (100) for transporting and storage of liquids adapted to be caged in a metal cage (200) comprising vertical (202) and horizontal (201) tubular elements, wherein said tank (100) comprises a bottom portion of a side wall (101) comprising a bottom recess (110) comprising a through hole adapted to mount a tap (111) to extract the fluid contained in the tank (100) and a top recess (10) arranged above the bottom recess (110), wherein said top recess (10) is symmetrical with respect to a vertical geometric axis of symmetry (S) which passes through a centre of the through hole of the bottom recess (110) and identifies a longitudinal direction of the top recess (10), wherein said top recess (10) comprises two first longitudinal ribs (20), wherein each first longitudinal rib (20) is a convex portion of the top recess (10) which protrudes towards the outside of the tank (100) with respect to side portions to the rib itself, wherein each first longitudinal rib (20) is arranged between a first concave recess portion (11) and a second concave recess portion (12), wherein each first concave recess portion (11) develops along a transverse direction starting from a side edge (16) of the top recess (10) up to the first longitudinal rib (20), wherein the second concave recess portion (12) is a central portion that develops along the transverse direction between the two first longitudinal ribs (20), wherein said top recess (10) provides that the first (11) and the second concave recess portion (12) comprise a substantially central concave portion (15) that develops along the longitudinal direction and a top convex portion (13) which starts from a top edge (17) of the top recess (10) and develops along the transverse direction and a bottom convex portion (14) which starts from a bottom edge (18) of



(84) **Designated States** (*unless otherwise indicated, for every kind of regional protection available*): ARIPO (BW, CV, GH, GM, KE, LR, LS, MW, MZ, NA, RW, SC, SD, SL, ST, SZ, TZ, UG, ZM, ZW), Eurasian (AM, AZ, BY, KG, KZ, RU, TJ, TM), European (AL, AT, BE, BG, CH, CY, CZ, DE, DK, EE, ES, FI, FR, GB, GR, HR, HU, IE, IS, IT, LT, LU, LV, MC, ME, MK, MT, NL, NO, PL, PT, RO, RS, SE, SI, SK, SM, TR), OAPI (BF, BJ, CF, CG, CI, CM, GA, GN, GQ, GW, KM, ML, MR, NE, SN, TD, TG).

**Published:**

- *with international search report (Art. 21(3))*
- *before the expiration of the time limit for amending the claims and to be republished in the event of receipt of amendments (Rule 48.2(h))*
- *in black and white; the international application as filed contained color or greyscale and is available for download from PATENTSCOPE*

---

the top recess (10) and develops along the transverse direction.

## REINFORCED TANK FOR TRANSPORTING AND STORAGE OF LIQUIDS

-----

The present invention relates to a reinforced tank for transporting and storage of liquids.

5 In the state of the art, tanks for transporting and storage of liquids are known, caged in metal cages. The metal cage serves to protect the tank and to contain the deformations of the shape of the tank itself. The tanks in fact have a parallelepiped shape which on one hand  
10 allows for rapid stacking, but on the other hand does not allow for balanced distribution of stresses on the surface of the tank. The metal cage is thus necessary to reinforce the shape of the tank and contain the deformation thereof.

15 In the state of the prior art, caged tanks comprising a bottom portion comprising a recess towards the inside of a volume of the tank. The recess comprises an inner wall where a through hole is drilled between the outside and the inside of the volume of the tank to  
20 which a tap is applied to extract the fluid contained in the tank.

The wall of the tank which is immediately above the recess for the tap is particularly subjected to deformations, in particular to bulging, because no  
25 vertical tubular element of the metal cage can pass in front of the tap, and thus no vertical tubular element passes in front of this portion of the wall.

In the state of the prior art, the part of the wall of the tank immediately above the recess for the tap  
30 comprises a top recess that partially limits the bulging deformation of the wall of the tank, but often deformations of the wall occur that are so large as to

cause breakages in this part of the wall, resulting in the dangerous release of the fluid contained in the tank.

An object of the present invention is to make a tank for transporting and storage of liquids that is reinforced and reduces the bulging deformation of the wall arranged above the recess designed for the tap.

According to the invention, such object is achieved with a tank for transporting and storage of liquids according to claim 1.

The features and advantages of the present invention will be more apparent from the following description, which is illustrative and not limiting, with reference to the attached schematic drawings in which:

figure 1 is a perspective view of a portion of a tank for transporting and storage of liquids according to the present invention, wherein the tank comprises a bottom portion of a side wall comprising a bottom recess. The bottom recess comprises a through hole mounting a tap to extract the fluid contained in the tank. The side wall comprises a top recess arranged immediately above the bottom recess for the tap, wherein the top recess comprises substantially vertical ribs, wherein the top recess is symmetrical with respect to a vertical geometric axis of symmetry;

figure 2 is a front view of a detail of the tank of figure 1 where the tank caged in a metal cage comprising vertical and horizontal tubular elements is shown. It should be noted that there is no vertical tubular element of the cage in front of the tap;

figure 3 is an enlarged view of detail A of figure 2 showing a left portion of the top recess of the side

wall;

figure 4 is a cross-sectional view along line IV-IV of figure 3;

figure 5 is a longitudinal sectional view along line  
5 V-V of figure 3;

figure 6 is a longitudinal sectional view along line VI-VI of figure 3;

figure 7 is a transverse view of the top recess;

figure 8 is a longitudinal view of the top recess.

10 With reference to the mentioned figures, a reinforced tank 100 for transporting and storage of liquids is shown.

The tank 100 comprises a bottom portion of a side wall 101 comprising a bottom recess 110. The bottom  
15 recess 110 comprises a through hole mounting a tap 111 to extract the fluid contained in the tank 100. The bottom portion of the side wall 101 also comprises a top recess 10 arranged just above the bottom recess 110 for the tap 111.

20 The top recess 10 is symmetrical with respect to a vertical geometric axis of symmetry S which passes through a centre of the side wall 101, through a centre of the through hole of the bottom recess 110 as shown in particular in figure 2 and lies on a geometric plane  $\Sigma$   
25 identified by the outer surface of the side wall 101. Therefore, in the description, reference will be made to figure 3 which shows the left portion of the top recess 10, as the right portion of the top recess 10 is symmetrical and thus it is sufficient to describe the  
30 left portion.

The vertical geometric axis of symmetry S is arranged along a longitudinal direction of the top recess

10.

Recess means a portion of the side wall 101 which protrudes towards the inside of the tank 100 with respect to a geometric plane  $\Sigma$  identified by an outer surface of the side wall 101.

The tank 100 is caged as shown in figure 2 inside a metal cage 200 comprising vertical 202 and horizontal 201 tubular elements.

It should be noted that in front of the tap 111 there can be no vertical tubular element 202 of the metal cage 200, therefore as explained above, top recesses of the state of the prior art have bulging deformations.

The top recess 10 of the present invention as shown in particular in figures 1-4, 7 comprises substantially vertical longitudinal ribs 20, 21 that are arranged along the longitudinal direction of the top recess 10.

Longitudinal rib 20, 21 means a convex portion of the top recess 10 which protrudes towards the outside with respect to side portions to the rib itself.

As shown in particular in figures 3, 4, and 7, the top recess 10 of the side wall 101 comprises two concave portions 11, 12 that recess towards the inside of the tank 100 along a transverse direction with respect to the outer surface of the side wall 101.

The transverse direction is perpendicular to the longitudinal direction.

The top recess 10 comprises two first longitudinal ribs 20 arranged symmetrically with respect to the vertical geometric axis S.

With particular reference to figures 3, 4, and 7, the first rib 20 is a convex portion of the top recess 10 that is arranged between a first concave recess

portion 11 and a second concave recess portion 12.

As shown in particular in figure 3, each first longitudinal rib 20 comprises two extreme portions 22 that increase the transverse dimensions of the first longitudinal rib 20 from a centre of the first longitudinal rib 20 both towards a top edge 17 and towards a bottom edge 18 of the top recess 10.

Preferably, the two extreme portions 22 of each first longitudinal rib 20 widen the transverse dimensions of the first longitudinal rib 20 towards the vertical geometric axis of symmetry S.

Each first longitudinal rib 20 comprises two extreme portions 22, a top extreme portion and a bottom extreme portion, each of which widens its transverse dimension towards the centre of the top recess 10 and towards the top 17 and bottom 18 edges of the top recess 10.

Transverse dimension means the width of the first longitudinal rib 20. The width of the first longitudinal rib 20 is not constant, but at the centre of the top recess 10 it is narrower than the two extreme portions 22 of the first longitudinal rib 20.

Additionally, preferably, the widening of the width of the first longitudinal rib 20 is not symmetrical, but it widens only towards the centre of the top recess 10, expanding its extreme portions 22 towards the first concave portion 12 in the direction of the vertical geometric axis of symmetry S.

Even more preferably, the top recess 10 comprises two second longitudinal ribs 21 arranged symmetrically with respect to the vertical geometric axis S.

With particular reference to figures 4 and 7, a

second rib 21 is arranged between the first concave recess portion 11 and a side edge 16 of the top recess 10.

The second rib 21 is a convex portion arranged  
5 between the side edge 16 of the top recess 10 and the first concave recess portion 11.

The second concave recess portion 12 is the central portion of the top recess 10.

Preferably, the first rib 20 is arranged in an  
10 intermediate position, preferably halfway, between the side edge 16 of the top recess 10 and the vertical geometric axis of symmetry S which passes through the centre of the top recess 10.

With particular reference to figures 4 and 7, each  
15 first concave recess portion 11 develops along a transverse direction starting from a side edge 16 of the top recess 10 up to the first longitudinal rib 20. The second concave recess portion 12 is a central portion that develops along the transverse direction between the  
20 two first longitudinal ribs 20 on the left and right.

Preferably, the first concave recess portion 11 comprises two bending radii, a first bending radius  $R_{111}$  for a first portion of the first concave recess portion 11 that develops along the transverse direction starting  
25 from the second longitudinal rib 21 and a second bending radius  $R_{112}$  for a second portion of the first concave recess portion 11 that develops along the transverse direction reaching the first rib 20.

Preferably, the first bending radius  $R_{111}$  is  
30 greater than the second bending radius  $R_{112}$ .

Even more preferably, a first portion of the first concave recess portion 11 which follows the first bending

radius  $R_{111}$  has a dimension along the transverse direction greater than a second portion of the first concave recess portion 11 which follows the second bending radius  $R_{112}$ , so as to create a more pronounced  
5 depression to the left with respect to figure 3 of the first longitudinal rib 20.

Preferably, the second concave recess portion 12 of the left portion shown in figures 4 and 7 provides a single bending radius, which is a third bending radius  
10  $R_{12}$ .

Preferably, the third bending radius  $R_{12}$  is between the first bending radius  $R_{111}$  and the second bending radius  $R_{112}$ .

The second concave recess portion 12 comprises a  
15 central portion arranged above the vertical geometric line of symmetry  $S$  which is arranged on a first bottom geometric plane  $\Theta$  that is parallel to the geometric plane  $\Sigma$  identified by the outer surface of the side wall 101, but at a smaller height than the outer surface of the  
20 side wall 101 as the first bottom geometric plane  $\Theta$  represents the most recessing level of the tank of the top recess 10.

Preferably, a fourth bending radius  $R_{20}$  of the first longitudinal rib 20 is smaller than a fifth bending  
25 radius  $R_{21}$  of the second longitudinal rib 21.

Even more preferably, in absolute value, the fourth bending radius  $R_{20}$  is smaller than the fifth bending radius  $R_{21}$ , which is smaller than the second bending radius  $R_{112}$ , which is smaller than the third bending  
30 radius  $R_{12}$ , which is smaller than the first bending radius  $R_{111}$ .

The shape of the top recess 10 along the

longitudinal direction is discussed below.

With particular reference to figures 3, 5, 6, and 8, the top recess 10 provides that the first 11 and the second concave recesses 12 comprise a substantially  
5 central concave portion 15 that develops along the longitudinal direction and two convex portions 13 and 14 that develop along the transverse direction which are respectively a top convex portion 13 which starts from a top edge 17 of the top recess 10 and a bottom convex  
10 portion 14 which starts from a bottom edge 18 of the top recess 10.

Preferably, a sixth bending radius  $R_{13}$  of the top convex portion 13 is lower than a seventh bending radius  $R_{14}$  of the bottom convex portion 14, as the bottom edge  
15 18 of the top recess 10 borders a more pronounced top edge of the bottom recess 110, while the top edge 17 of the top recess 10 is levelled with the rest of the side wall 101.

Preferably, the top edge of the bottom recess 110  
20 can be at a height level greater than the geometric plane  $\Sigma$  identified by the side wall 101, in the sense that it rises towards the outside of the tank 100 with respect to the geometric plane  $\Sigma$ .

Preferably, the bottom edge 18 of the top recess 10  
25 is at a height level smaller than the geometric plane  $\Sigma$ , so as to create a central base portion 19 whose innermost level of the tank 100 lies on a second bottom geometric plane  $\Psi$  that is parallel to the geometric plane  $\Sigma$  and does not necessarily correspond to the first bottom  
30 geometric plane  $\Theta$  described above.

Advantageously, the concave and convex portions described above of the top recess 10 allow to reinforce

the top recess 10 and surprisingly reduce the bulging deformation of the top recess 10, avoiding breakages of the side wall 101.

Alternatively, the first concave recess portion 11  
5 has a single bending radius and the first R<sub>111</sub> and the second R<sub>112</sub> bending radii are equal.

Alternatively, the second concave recess portion 12 of the left portion provides two different bending radii.

Alternatively, the first rib 20 comprises a  
10 substantially constant width along the transverse direction, so according to this alternative the first rib 20 does not comprise two extreme portions 22.

Alternatively, the top recess 10 comprises only the first longitudinal ribs 20 and does not comprise the  
15 second longitudinal ribs 21.

Alternatively, according to an exemplary embodiment, the tank 100 for transporting and storage of liquids is adapted to be caged in the metal cage 200 comprising vertical 202 and horizontal 201 tubular  
20 elements. Said tank 100 comprises a bottom portion of the side wall 101 comprising the bottom recess 110 comprising the through hole adapted to mount the tap 111 to extract the fluid contained in the tank 100 and the top recess 10 arranged above the bottom recess 110. Said  
25 top recess 10 is symmetrical with respect to a vertical geometric axis of symmetry S which passes through a centre of the through hole of the bottom recess 110 and identifies a longitudinal direction of the top recess 10. Said top recess 10 comprises two first longitudinal  
30 ribs 20. Each first longitudinal rib 20 is a convex portion of the top recess 10 which protrudes towards the outside of the tank 100 with respect to side portions to

the rib itself. Each first longitudinal rib 20 is arranged between a first concave recess portion 11 and a second concave recess portion 12. Each first concave recess portion 11 develops along a transverse direction starting from a side edge 16 of the top recess 10 up to the first longitudinal rib 20. The second concave recess portion 12 is a central portion that develops along the transverse direction between the two first longitudinal ribs 20. Said top recess 10 provides that the first 11 and the second concave recess portion 12 comprise a substantially central concave portion 15 that develops along the longitudinal direction and a top convex portion 13 which starts from a top edge 17 of the top recess 10 and develops along the transverse direction and a bottom convex portion 14 which starts from a bottom edge 18 of the top recess 10 and develops along the transverse direction.

The invention thus conceived is susceptible to numerous modifications and variants, all falling within the scope of the inventive concept. In practice, the materials used, as well as the dimensions, can be any according to technical requirements.

## CLAIMS

1. Tank (100) for transporting and storage of liquids adapted to be caged in a metal cage (200) comprising vertical (202) and horizontal (201) tubular  
5 elements,

wherein said tank (100) comprises a bottom portion of a side wall (101) comprising a bottom recess (110) comprising a through hole adapted to mount a tap (111) to extract the fluid contained in the tank (100) and a  
10 top recess (10) arranged above the bottom recess (110),

wherein said top recess (10) is symmetrical with respect to a vertical geometric axis of symmetry (S) which passes through a centre of the through hole of the bottom recess (110) and identifies a longitudinal  
15 direction of the top recess (10),

wherein said top recess (10) comprises two first longitudinal ribs (20),

wherein each first longitudinal rib (20) is a convex portion of the top recess (10) which protrudes towards  
20 the outside of the tank (100) with respect to side portions to the rib itself,

wherein each first longitudinal rib (20) is arranged between a first concave recess portion (11) and a second concave recess portion (12),

25 wherein each first concave recess portion (11) develops along a transverse direction starting from a side edge (16) of the top recess (10) up to the first longitudinal rib (20),

wherein the second concave recess portion (12) is  
30 a central portion that develops along the transverse direction between the two first longitudinal ribs (20),

wherein said top recess (10) provides that the first

(11) and the second concave recess portion (12) comprise a substantially central concave portion (15) that develops along the longitudinal direction and a top convex portion (13) which starts from a top edge (17) of the top recess (10) and develops along the transverse direction and a bottom convex portion (14) which starts from a bottom edge (18) of the top recess (10) and develops along the transverse direction.

2. Tank (100) according to claim 1, characterized in that said top recess (10) comprises two second longitudinal ribs (21),

wherein each second longitudinal rib (21) is a convex portion arranged between the side edge (16) of the top recess (10) and the first concave recess portion (11).

3. Tank (100) according to any one of the preceding claims 1 or 2, characterized in that each first rib (20) is arranged in an intermediate position between the side edge (16) of the top recess (10) and the vertical geometric axis of symmetry (S).

4. Tank (100) according to any one of the preceding claims 1-3, characterized in that each first longitudinal rib (20) comprises two extreme portions (22) that increase the transverse dimensions of the first longitudinal rib (20) from a centre of the first longitudinal rib (20) both towards a top edge (17) and towards a bottom edge (18) of the top recess (10).

5. Tank (100) according to claim 4, characterized in that the two extreme portions (22) of each first longitudinal rib (20) widen the transverse dimensions of the first longitudinal rib (20) towards the vertical geometric axis of symmetry (S).

6. Tank (100) according to any one of the preceding claims, characterized in that each first concave recess portion (11) comprises two bending radii, a first bending radius (R<sub>111</sub>) for a first portion of the first concave recess portion (11) that develops along the transverse direction starting from the side edge (16) and a second bending radius (R<sub>112</sub>) for a second portion of the first concave recess portion (11) that develops along the transverse direction reaching the first longitudinal rib (20).

7. Tank (100) according to claim 6, characterized in that the first bending radius (R<sub>111</sub>) is greater than the second bending radius (R<sub>112</sub>).

8. Tank (100) according to any one of the preceding claims 6 or 7, characterized in that a first portion of the first concave recess portion (11) which follows the first bending radius (R<sub>111</sub>) has a dimension along the transverse direction greater than a second portion of the first concave recess portion (11) which follows the second bending radius (R<sub>112</sub>).

9. Tank (100) according to any one of the preceding claims, characterized in that said second concave recess portion 12 of the left portion provides at least one bending radius which is at least a third bending radius (R<sub>12</sub>).

10. Tank (100) according to any one of the preceding claims, characterized in that a bending radius (R<sub>13</sub>) of the top convex portion (13) is lower than a bending radius (R<sub>14</sub>) of the bottom convex portion (14).

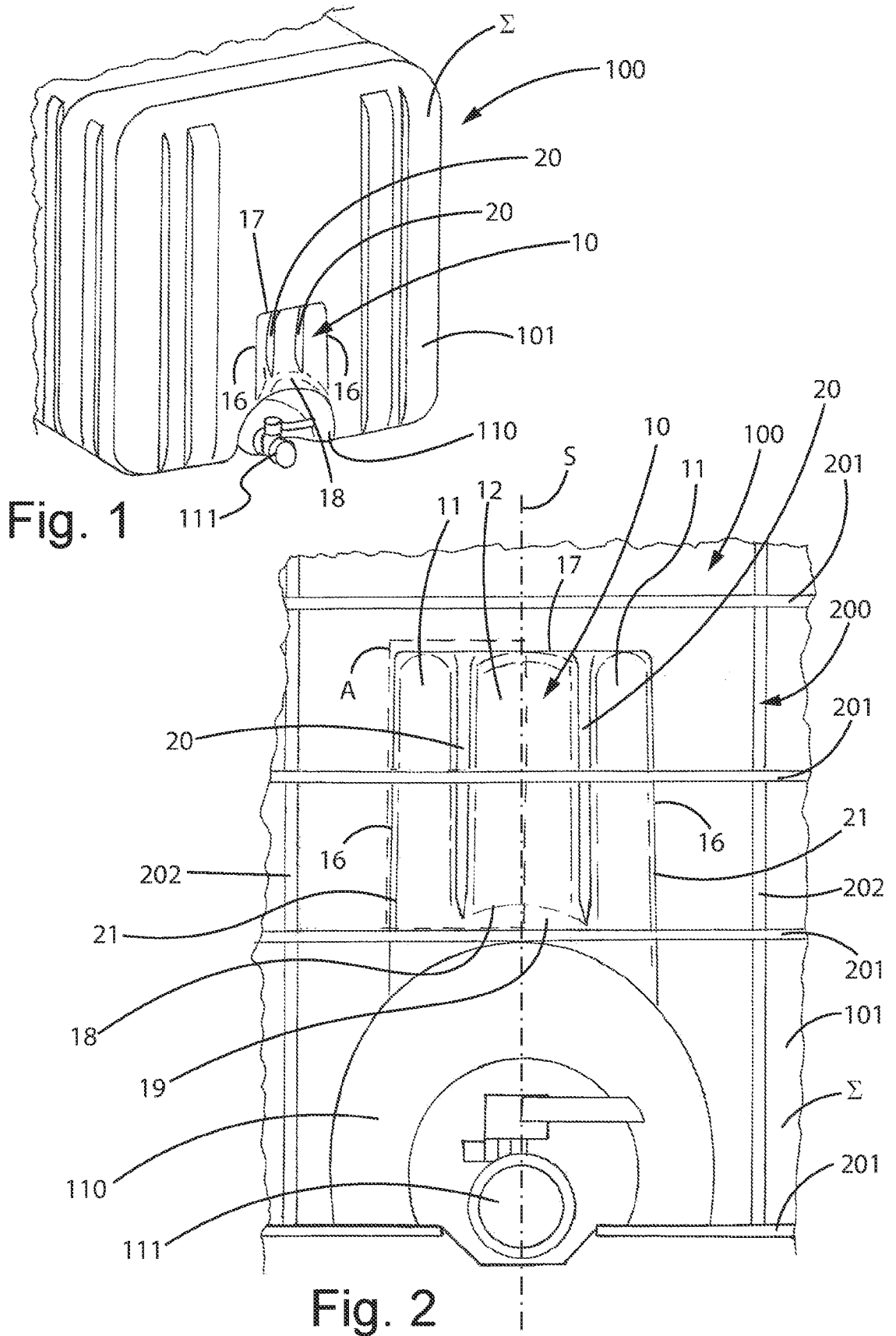

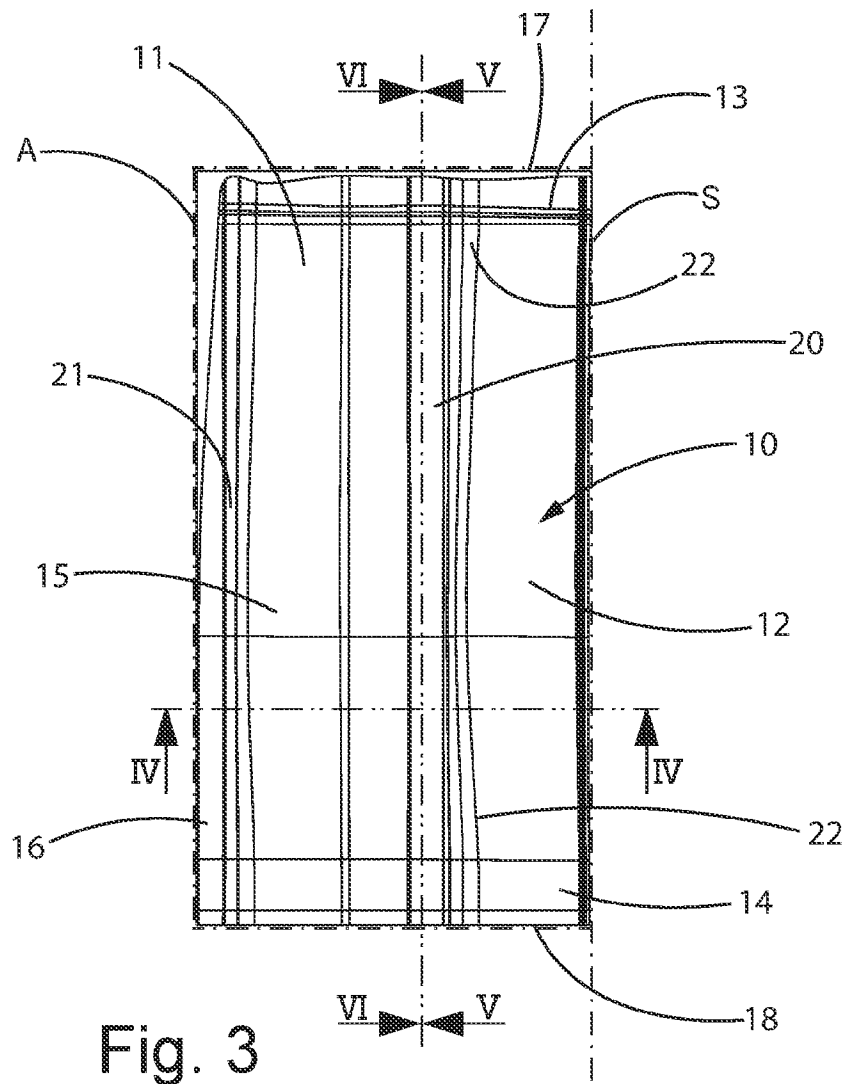

Fig. 3

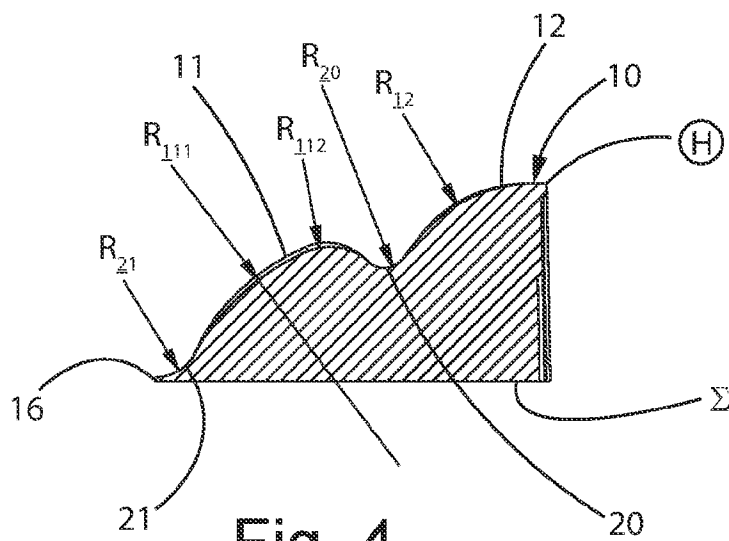

Fig. 4

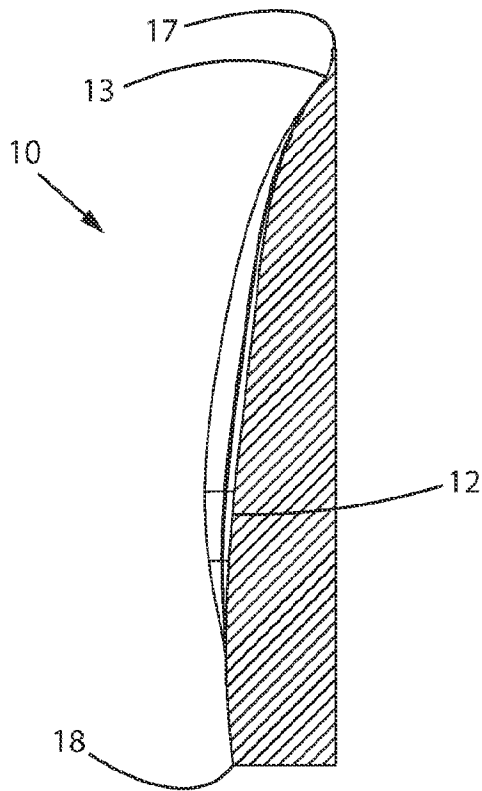

Fig. 5

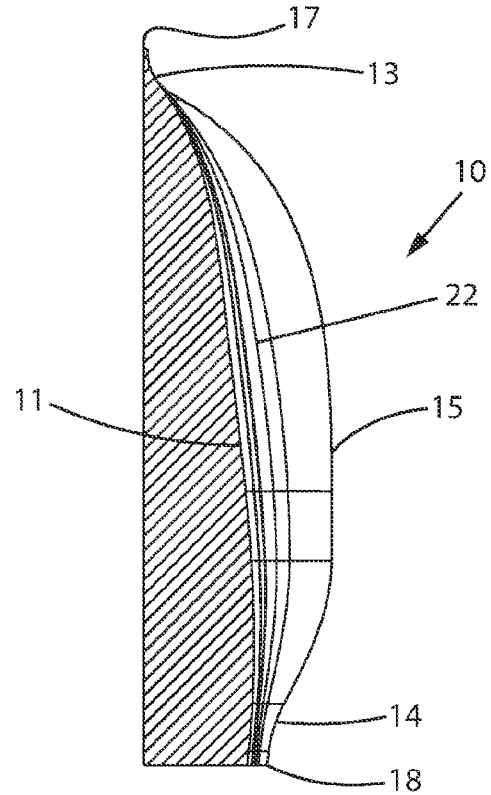

Fig. 6

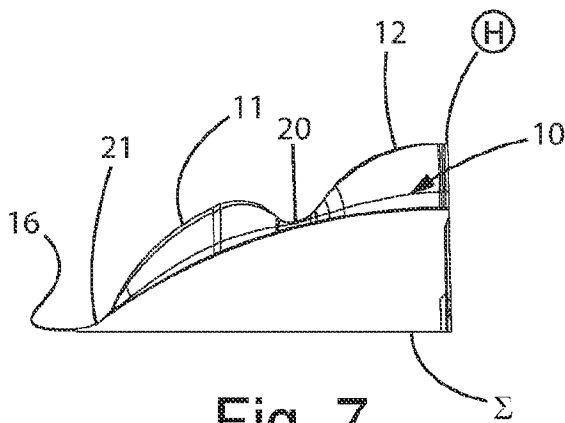

Fig. 7

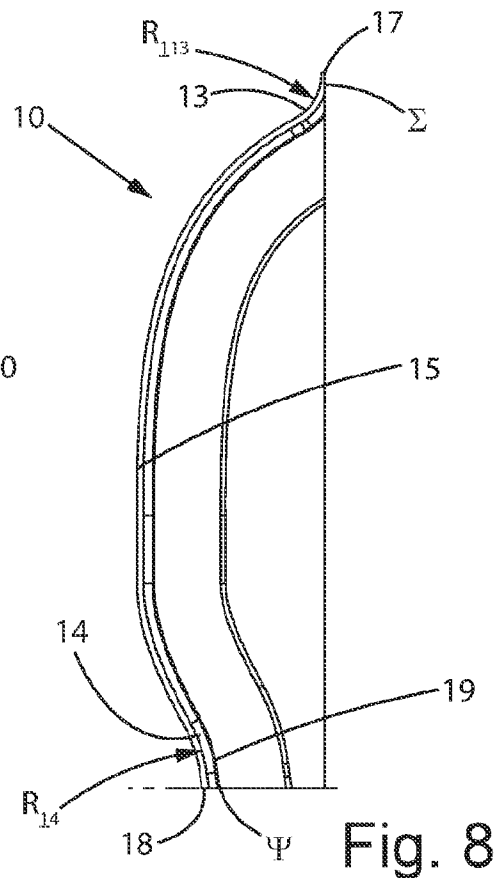

Fig. 8

# INTERNATIONAL SEARCH REPORT

International application No PCT/IB2024/055569
---------------------------------------------------

<b>A. CLASSIFICATION OF SUBJECT MATTER</b> INV. B65D77/04 ADD.				
According to International Patent Classification (IPC) or to both national classification and IPC				
<b>B. FIELDS SEARCHED</b>				
Minimum documentation searched (classification system followed by classification symbols) <b>B65D</b>				
Documentation searched other than minimum documentation to the extent that such documents are included in the fields searched				
Electronic data base consulted during the international search (name of data base and, where practicable, search terms used) <b>EPO-Internal</b>				
<b>C. DOCUMENTS CONSIDERED TO BE RELEVANT</b>				
Category*	Citation of document, with indication, where appropriate, of the relevant passages	Relevant to claim No.		
A	WO 2015/042651 A1 (FLEXTANK INTERNAT LTD [AU]) 2 April 2015 (2015-04-02) figures 1, 2 -----	1 - 10		
A	CN 103 964 046 A (MA YURONG) 6 August 2014 (2014-08-06) figure 2 -----	1 - 10		
A	DE 195 25 152 A1 (SOTRALENTZ SA [FR]) 13 June 1996 (1996-06-13) figures 1, 3 -----	1 - 10		
<table style="width: 100%; border: none;"> <tr> <td style="width: 50%; border: none;"><input type="checkbox"/> Further documents are listed in the continuation of Box C.</td> <td style="width: 50%; border: none;"><input checked="" type="checkbox"/> See patent family annex.</td> </tr> </table>			<input type="checkbox"/> Further documents are listed in the continuation of Box C.	<input checked="" type="checkbox"/> See patent family annex.
<input type="checkbox"/> Further documents are listed in the continuation of Box C.	<input checked="" type="checkbox"/> See patent family annex.			
* Special categories of cited documents :				
"A" document defining the general state of the art which is not considered to be of particular relevance "E" earlier application or patent but published on or after the international filing date "L" document which may throw doubts on priority claim(s) or which is cited to establish the publication date of another citation or other special reason (as specified) "O" document referring to an oral disclosure, use, exhibition or other means "P" document published prior to the international filing date but later than the priority date claimed	"T" later document published after the international filing date or priority date and not in conflict with the application but cited to understand the principle or theory underlying the invention "X" document of particular relevance; the claimed invention cannot be considered novel or cannot be considered to involve an inventive step when the document is taken alone "Y" document of particular relevance; the claimed invention cannot be considered to involve an inventive step when the document is combined with one or more other such documents, such combination being obvious to a person skilled in the art "&" document member of the same patent family			
Date of the actual completion of the international search	Date of mailing of the international search report			
<b>24 September 2024</b>	<b>04/10/2024</b>			
Name and mailing address of the ISA/ European Patent Office, P.B. 5818 Patentlaan 2 NL - 2280 HV Rijswijk Tel. (+31-70) 340-2040, Fax: (+31-70) 340-3016	Authorized officer  <b>Balz, Oliver</b>			

# INTERNATIONAL SEARCH REPORT

Information on patent family members

International application No

PCT/IB2024/055569

Patent document cited in search report	Publication date	Patent family member(s)	Publication date
WO 2015042651	A1	02-04-2015	
		AU 2014328470 A1	12-05-2016
		CA 2925607 A1	02-04-2015
		CL 2016000739 A1	03-03-2017
		CN 105593132 A	18-05-2016
		EP 3052398 A1	10-08-2016
		US 2016221729 A1	04-08-2016
		WO 2015042651 A1	02-04-2015
-----			
CN 103964046	A	06-08-2014	NONE
-----			
DE 19525152	A1	13-06-1996	NONE
-----			