



- (51) **International Patent Classification:**  
*G01F 1/075* (2006.01)
- (21) **International Application Number:**  
PCT/PL2012/000015
- (22) **International Filing Date:**  
23 March 2012 (23.03.2012)
- (25) **Filing Language:** English
- (26) **Publication Language:** English
- (30) **Priority Data:**  
P.394473 7 April 2011 (07.04.2011) PL
- (71) **Applicant (for all designated States except US):** **FILA, ANTONI POLSKA FABRYKA WODOMIERZY I CIEPLOMIERZY FILA** [PL/PL]; Ul. Żeromskiego 30, PL-82-400 Sztum (PL).
- (72) **Inventor; and**
- (75) **Inventor/Applicant (for US only):** **FILA, Antoni** [PL/PL]; Czernin Os. Przyleśne 1, PL-82-400 Sztum (PL).
- (74) **Agent:** **CZABAJSKI, Jacek**; TRASET Biuro Patentowe S.C., Ul. Piecewska 27, PL-80-288 Gdańsk (PL).
- (81) **Designated States (unless otherwise indicated, for every kind of national protection available):** AE, AG, AL, AM, AO, AT, AU, AZ, BA, BB, BG, BH, BR, BW, BY, BZ, CA, CH, CL, CN, CO, CR, CU, CZ, DE, DK, DM, DO,

DZ, EC, EE, EG, ES, FI, GB, GD, GE, GH, GM, GT, HN, HR, HU, ID, IL, IN, IS, JP, KE, KG, KM, KN, KP, KR, KZ, LA, LC, LK, LR, LS, LT, LU, LY, MA, MD, ME, MG, MK, MN, MW, MX, MY, MZ, NA, NG, NI, NO, NZ, OM, PE, PG, PH, PL, PT, QA, RO, RS, RU, RW, SC, SD, SE, SG, SK, SL, SM, ST, SV, SY, TH, TJ, TM, TN, TR, TT, TZ, UA, UG, US, UZ, VC, VN, ZA, ZM, ZW.

(84) **Designated States (unless otherwise indicated, for every kind of regional protection available):** ARIPO (BW, GH, GM, KE, LR, LS, MW, MZ, NA, RW, SD, SL, SZ, TZ, UG, ZM, ZW), Eurasian (AM, AZ, BY, KG, KZ, MD, RU, TJ, TM), European (AL, AT, BE, BG, CH, CY, CZ, DE, DK, EE, ES, FI, FR, GB, GR, HR, HU, IE, IS, IT, LT, LU, LV, MC, MK, MT, NL, NO, PL, PT, RO, RS, SE, SI, SK, SM, TR), OAPI (BF, BJ, CF, CG, CI, CM, GA, GN, GQ, GW, ML, MR, NE, SN, TD, TG).

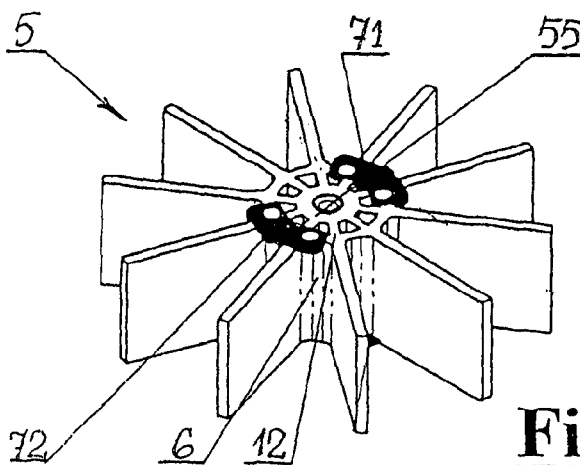
**Declarations under Rule 4.17:**

— of inventorship (Rule 4.17(iv))

**Published:**

- with international search report (Art. 21(3))
- before the expiration of the time limit for amending the claims and to be republished in the event of receipt of amendments (Rule 48.2(h))

(54) **Title:** VELOCITY TYPE FLOW METER WITH ELECTRONIC READOUT



**Fig. 4**

(57) **Abstract:** The flow meter with electronic readout, composed of the body (I) with the impeller chamber, along with the water inlet (2) and outlet connector pipe (3). The impeller chamber is closed with the upper cover (4), including the electronic system and in this chamber there is the impeller (5) installed on the axle (51), which is perpendicular to the direction (A) of water flow. To the hub (6) of the impeller (5) one attached the indicator of revolutions of the impeller (5) in a form of a set of dampening elements (71,72). The electronic system RLC (II) is fastened in the cover (4) and it emits, by means of the coil (14), a constant stream of electric impulses aimed in the direction of the line of revolutions of the dampening elements (71,72). On the other side of the hub (6) one attached a set of balancing elements (73).



### Velocity type flow meter with electronic readout

The object of the invention is a velocity-type flow meter with electronic readout used for measurement of volumetric flow of a fluid, and in particular, of water, installed on a pipeline. A water meter is a device for application particularly on water pipes in cold and hot water supply systems.

According to the known solutions, flow meters, and in particular velocity type flow meters, are the devices with a counting system coupled with an impeller in the form of a paddle wheel. In the water meter body in the impeller chamber there is an impeller of a paddle wheel nature, mounted on a single axle or on two axles, on the axis perpendicular to the direction of liquid flow. Fluid flows through the impeller chamber in the direction perpendicular to the axis of rotation of the impeller, causing its rotation that is proportional to flow rate. The number of revolutions of the impeller depends on the volumetric flow rate of the liquid. The known flow meter is usually equipped with a non-contact sensor of the number of revolutions. A signal from the sensor, after its

transformation, is used for calculations as an impulse signal. The number of impulses is proportional to the value of fluid flow inside the pipe.

In the solution known from the Japanese patent description No. JP 56100313 a magnetic flow meter was presented. According to this solution, permanent magnets are fastened to the flange on the axle of the impeller that rotates proportionally to water consumption. Electric impulses are generated in a magnetic sensor, depending on the revolutions of the flange with magnets, counted in an electronic counter and displayed on a liquid crystal display LCD. Magnets are produced with angular position to the axis of rotation of the impeller. Thus the linear magnetic force generated by permanent magnets is flat and the magnetic sensor may be placed in the neighborhood of the magnet, without any impact on impeller revolutions, despite its small dimensions, which may be increased, depending on needs.

A different solution of a magnetic flow meter was presented in another Japanese patent description No. JP 56094219. In this known solution in the water meter chamber there is an impeller with a permanent magnet. The revolutions of this magnet, in proportion to the revolutions of the impeller, are transformed into electric impulses by way of transmitting them through a cover of the water meter chamber to the magnetic sensor and thus the flow rate of water is measured by an electronic circuit, constituting an electronic counter with LCD and the source of power supply. In the electronic circuit between the lower housing and the upper housing there is a seal and its connection surface is permeable for ultrasonic waves. The electronic circuit is integrated on the counter part of the water meter with the

application of a seal, a combining ring and it includes the next elements of the system in a separated moisture-resistant space of the water meter aimed for the electronic circuit.

Another known solution of a flow meter with electronic readout was presented in the Japanese patent description No. JP 2003207376. In this known solution a connector pipe is combined with a water pipe nozzle. When water flows, the impeller in the impeller chamber rotates. A photoelectric sensor detects the light reflected on the reflector, fastened on the impeller plate, and transmits impulse signals to the display assembly in the form of voltage impulses. Water consumption is displayed basing on the transmitted signals.

Flow meters are equipped with electronic flow indicators, so they include an electronic system that counts the impulses induced by a signal transmitter, normally located on the axle of the flow meter impeller, for example by a magnetic element in cooperation with the Hall sensor. Impulses are counted and multiplied by the amount of flowing fluid, determined on the measuring station for a given type of a water counter. The result is presented on the display in the form of volume of the fluid that flew through the water meter body in a specific period of time.

What is problematic is the measurement of flow rate in the conditions of lower limit of extreme flows, i.e. the flows close to the nominal scope, as well as in the conditions of the upper limit of extreme flows, above the nominal scope of a flow meter, but also in the scope of nominal flows, where one can also note many times a non linear characteristics of water meter error. In the extreme conditions the values of fluid flow often substantially deviate from the nominal values stored in memory of the counter.

In the flow meters of this kind the wet part is usually a cylindrical chamber of the impeller, inside of which there is a rotationally-installed impeller in the form of a paddle wheel with the axis of rotation that is perpendicular to the liquid flow direction. On the axle of the impeller one fastened radial blades. The stream of liquid flowing through the impeller chamber, directed by way of location of the liquid inlet and outlet pipe nozzles to/from the impeller chamber to one of the sides of the chamber, activates the rotation of the impeller with a rotational speed proportional to the volumetric flow rate of the liquid. Revolutions of the impeller in the unit of time are counted and transformed in a mechanical or electronic system in the counting part of the water meter. As indicated above, in electronic water meters one applies, first of all, the readout of magnetic impulses coming from a permanent magnet or magnets, fastened to the impeller and read by a stationary magnetic sensor, attached to the water meter housing. The solution of this kind results in susceptibility of the water meter to the external interference with a magnetic field.

In the known state of the art solutions, the basic problem is the accuracy of indications, along with the changes in liquid flow rate. A special problem consists in maintaining of the accuracy of measurement in the lowest values of flow, in the neighborhood and below the minimal flow of the flow meter. In the area of flow that is slightly above the start-up threshold the impeller operates in an unstable way and it may even stop; it does not indicate the values of liquid flow then. It causes substantial errors in indications in these areas of operation of the flow meter. The purpose of the

invention is to decrease the value of minimal flow  $Q_1$  of the flow meter and the value of its start-up threshold.

According to the invention, the flow meter with electronic readout is composed of a body with an impeller chamber, along with a water inlet and outlet pipe nozzles, and the impeller chamber is closed with an upper cover, and in this impeller chamber there is an impeller installed on the axle that is perpendicular to the liquid flow direction. To a hub of the impeller one fastened the elements that dampen vibrations of an electromagnetic circuit. In a dry chamber of the upper cover there is a receiver of indicator signals, connected with a counter and including a display of measurement values and optionally, a transmitter with an antenna.

What is characteristic of the flow meter according to this invention, is that the receiver of signals of revolutions of the impeller forms the RLC electronic system, emitting a constant stream of electric impulses, aimed in the direction of the line of revolutions of the dampening element. The notion of the line of revolutions of the dampening element is defined as a circle, on whose path the dampening element moves; this element is fastened on the hub of the impeller. Along with the impeller, the dampening element installed on the plane of the hub of the impeller rotates around the axis of rotation of the impeller. The dampening element moves along the line of the circle, whose radius determines the distance from the axis of symmetry of the impeller to the points of fastening of the dampening element on the plane of the hub of the impeller, perpendicular to the axis of rotation.

On the other side of the hub, on the opposite plane of the hub of the impeller, perpendicular to the axis of rotation,

one fastened the second dampening element, with the same mass as the first dampening element. In a different solution according to the invention, the indicator of revolutions of the impeller may be a pair of dampening elements attached on one side of the impeller, on the plane of the hub of the impeller, perpendicular to the axis of rotation. In this solution both dampening elements are distributed symmetrically to one another, on a theoretical line of diameter of this hub of the impeller. In this solution on the other side of the hub of the impeller one installed the opposite second pair of dampening elements, with the same mass as the first pair of the dampening elements, forming an indicator of revolutions of the impeller. The second pair of the dampening elements is also fastened symmetrically on the line of diameter of the other side of the hub of the impeller. The purpose of such a location of both pairs of the dampening elements is to obtain uniformity of distribution of mass of the impeller in the flowing liquid, along with the other components of the impeller, such as sleeves, a thrust bearing and the dampening elements, both in the plane that is perpendicular to the axle of the impeller going through the center of the impeller, and in the plane that is parallel to the axle of the impeller going through the center of the impeller.

According to the invention, it is planned that the weight of the complete impeller favorably corresponds to the weight of fluid displaced by this impeller. In addition, it is expected that the center of buoyancy of the impeller coincides with its center of gravity.

In the solution according to this invention new means are suggested, aimed at lowering of thrust on the axle of the

impeller, resulting from non-uniformity of distribution of weight of the impeller.

Another unfavorable phenomenon, which was eliminated in the solution according to this invention, is the issue of lack of balancing of weight of the impeller itself, which is the cause of earlier wear of bearings of the impeller axles and impacts increasing inaccuracy of indications of the flow meter. The impeller with a weight equal to the weight of displaced water maintains a relative weightlessness in the water environment and does not put up practical resistance resulting from its deadweight, which is of particular importance in case of water flows in the lower limits of the stream of volume of the flow meter, where the most serious errors of indication are usually noted. As was found as a result of examination, the solution according to this invention allows to obtain a serious progress in the accuracy of indications of the flow meter, in case of small values of the stream of volume, that was not obtained in the known solutions.

The object of invention was presented in the examples of construction in the attached figures, basing on the example of a water meter, on which the respective drawing figures are showed:

- Fig. 1 - bottom view of the water meter,
- Fig. 2 - top view of the water meter,
- Fig. 3 - section of the water meter in the first example,
- Fig. 4 - top view of the impeller in the first example,
- Fig. 5 - bottom view of the impeller in the first example,
- Fig. 6 - section of the water meter in the second example,

- Fig. 7 - top view of the impeller in the second example,  
Fig. 8 - bottom view of the impeller in the second example,  
Fig. 9 - section of the water meter in the third example,  
Fig. 10 - top view of the impeller in the third example,  
Fig. 11 - bottom view of the impeller in the third example,  
Fig. 12 - view of the impeller according to fig. 4 in the  
direction conforming to the axis of rotation of the  
impeller,  
Fig. 13 - view of the dampening element,  
Fig. 14 - view of the impeller in the fourth example.

As presented in the attached figures fig. 1 and fig. 2, the water meter with electronic readout is composed of the body 1 with the impeller chamber, along with water inlet connector pipe 2 and outlet connector pipe 3. In the figures: fig. 3, fig. 6, fig. 9 it was presented that the impeller chamber is closed with the upper closing plate 4 and that there is the impeller 5 in the impeller chamber, located on the axle 51, 52, 53, perpendicular to the direction of water flow. To the hub 6 of the impeller 5 one attached a dampening element 71. The electronic system composed of the electronic board 11, the display 9, the battery 15 and the antenna 10, located in the dry chamber 8 and the coil 14 located in the plate that closes the water meter 4, detects motion of the dampening elements 71,72 on the line of revolutions.

As shown in the fig. 4 and fig. 5, in the first example of construction, to the hub of the impeller one fastened two dampening elements 71,72. The electronic system emits a stream of electromagnetic impulses, aimed in the direction of the line of revolutions of the dampening elements 71,72. The notion of the line of revolutions of the dampening elements

71,72 is defined as a circle, on whose path the dampening elements 71,72 move, which are fastened on the hub 6 of the rotational impeller 5. Along with revolutions of the impeller 5 the dampening elements 71,72, fastened on the plane 12 of the hub 6 of the impeller 5, rotate around the axis of rotation 51,52,53 of the impeller 5. The dampening elements 71,72 move along the line of the circle, whose radius determines the distance from the axis of symmetry of the impeller 5 to the point of fastening of the dampening elements 71,72 on the plane 12 of the hub 6 of the impeller 5, perpendicular to the axis of rotation.

On the other side of the hub 6, on the opposite plane 13 of the hub of the impeller 5, perpendicular to the axis of rotation, there are fastened two balancing dampening elements 73, with the same mass as the first two dampening elements 71,72, constituting the indicator of revolutions of the impeller.

In the examples of construction presented in the attached figures, the dampening elements 71,72 constituting the indicator of revolutions of the impeller 5, form a pair of elements fastened on one side of the hub of the impeller, on the plane 12 of the hub 6 of the impeller 5, perpendicular to the axis of rotation. In this solution both dampening elements 71,72 are distributed symmetrically to one another, on a theoretical line of diameter of this hub 6 of the impeller 5. It was shown in the attached fig. 4, fig. 7 and fig. 10. In this example of solution on the other side of the hub 6 of the impeller 5, on the plane 13 one fastened the opposite second pair of the elements 73, with the same mass as the pair of elements that constitute the indicators 71,72. This second pair of balancing elements 73 is also fastened symmetrically

on the line of diameter of the second plane 13 of the hub 6 of the impeller 5.

In the described example of construction, presented in the figures, the weight of the impeller along with the components of the impeller, such as sleeves, a thrust bearing and dampening elements 71,72 and with the balancing elements 73 on the other side of the hub 6 of the impeller 5, is equal to the weight of fluid displaced by this complete impeller.

In the figures: fig. 3, fig. 4 and fig. 5 one presented the first example of construction of the water meter, according to the invention. In this example of construction the impeller 5 includes two dampening elements 71,72, two balancing elements 73, two slide bearings 55, inside of which there are located two axle shafts 51 that are not the parts of the impeller 5 and are separated with at least one sapphire stone 54. In other examples of construction one does not exclude the application of a different number of sapphire stones 54, as well as of a different number of dampening elements 71,72 and balancing elements 73.

In the figures: fig. 6, fig. 7 and fig. 8 one presented the second example of construction of the water meter, according to the invention. In this example of construction the impeller 5 has the axle shaft 52 on one side, and the sleeve 55 on the other side, inside of which there is the second axle shaft 51, which is not a part of the impeller 5. This axle 51 is located in the body of the water meter 1 and it is supported on the thrust bearing, i.e. the sapphire stone 54 located in the impeller 5. The impeller includes two dampening elements 71,72. In this example of construction, in the impeller 5 from the side of the sleeve 55 there is a balancing ring 74. In other examples of construction one does

not exclude the use of a different number of dampening elements 71,72 and of balancing elements 74.

In the figures: fig. 9, fig. 10 and fig. 11 one presented the third example of construction of the water meter according to the invention. In this example of construction the impeller 5 includes two dampening elements 71,72, two balancing elements 73, and two axle shafts 53, forming a part of the impeller 5. The axle shafts 53 are situated in the openings in the body 5 and in the upper cover 4 of the chamber of the impeller 5. In other examples of construction one does not exclude the use of a different number of dampening elements 71,72 and of balancing elements 73.

In the fig. 12 one presented the impeller 5 in a view conforming to the axis of rotation of this impeller. As shown, on the plane 12 of the hub 6, one fastened symmetrically two dampening elements 71,72. The dampening elements 71,72 were shown in detail in the figure 13. The elements 71,72 are made from chromium steel H17. The whole impeller, along with the hub 6 and the blades, is made from polypropylene. In the example of construction presented in the figure 12, the complete impeller includes the dampening elements 71,72 on the plane 12 and the balancing elements 73 on the opposite plane 13 of the hub 6. The balancing elements 73 are also made from steel H17, of the same shape as the dampening elements 71,72.

The complete impeller presented in the figure 12, with a diameter  $\varnothing$  44,8 mm has the mass of 3,69g and the volume of 3,69 cm<sup>3</sup>. Thus, the complete impeller 5 weights as much, as the water it displaces, and additionally, according to the solution presented in the invention, it is balanced on the axis. In the described example the measurements made on both sides of the measurement axis of rotation of the impeller 5,

yielded the following results: the mass on the left-hand side amounting to 1,845g and the mass on the right-hand side also amounting to 1,845g. In a model impeller applied in dry-running water meters with magnetic coupling produced so far, not balanced according to the invention, mass distribution on the left-hand side amounts to 0,38g and on the right-hand side -0,25g. It does not limit the possibility of constructing of a flow meter according to the invention with different sizes of the impeller 5.

In other examples of construction of the water meter according to the invention one may assume a different number of dampening elements 71,72 on the impeller, as well as a different number or a different form of the balancing elements 73, provided, however, that the principle of balancing of the entire impeller 5 is maintained, both in the plane parallel to the axis of rotation of the impeller 5, and in the plane that is perpendicular to the axis of rotation of the impeller 5, and provided that the condition of maintaining of the total weight of the impeller 5 is respected, equal to the weight of the fluid displaced by this complete impeller 5. In the presented examples of construction in the impeller 5 the center of buoyancy coincides with the center of gravity.

The list of marks in the drawings

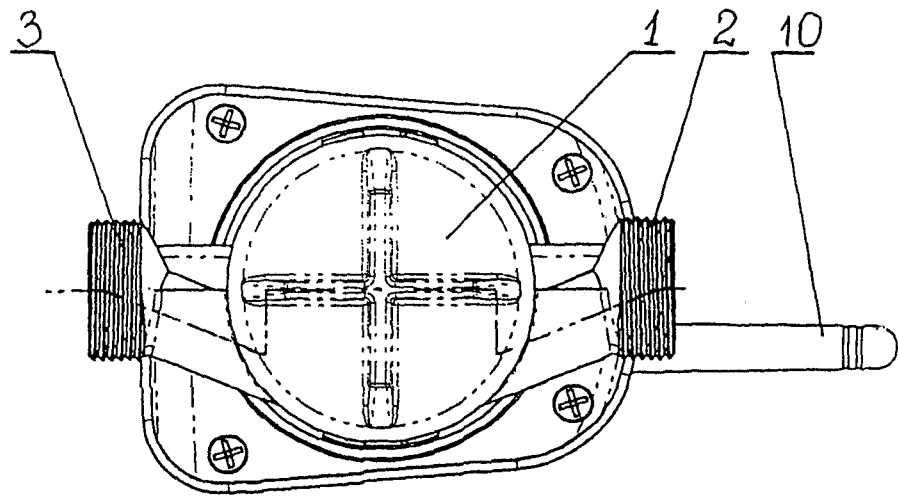
1. Body
2. Water inlet connector pipe
3. Water outlet connector pipe
4. Water meter closing plate
5. Impeller
51. Axle shaft of the impeller
52. Axle shaft of the impeller
53. Axle of the impeller
54. Sapphire stone
55. Sleeve
6. Hub of the impeller
71. Damping element
72. Damping element
73. Balancing element
74. Balancing ring
8. Dry chamber
9. Display
10. Antenna
11. Electronic board
12. Plane of the impeller hub
13. Plane of the impeller hub
14. Coil
15. Battery
- A. Water flow direction

Patent Claims

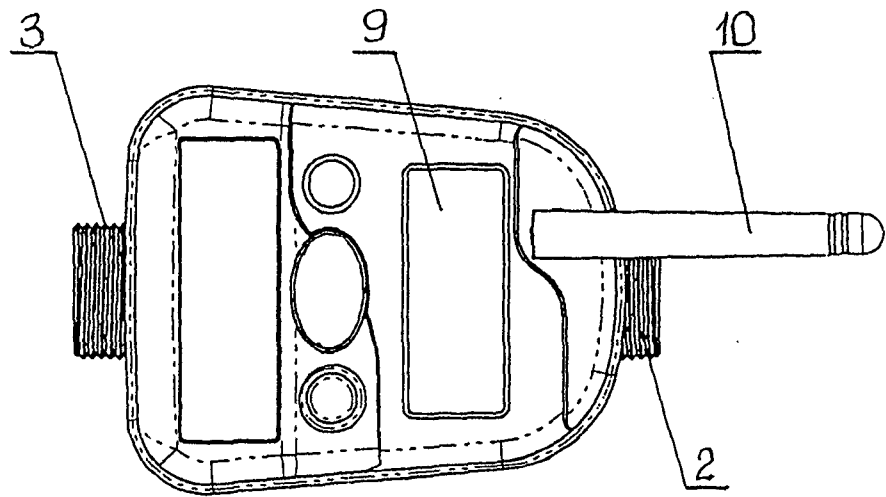
1. Velocity-type flow meter with electronic read-out, composed of the body with an impeller chamber, as well as with a liquid inlet and outlet connector pipe; the impeller chamber is closed with the upper cover and in this impeller chamber there is the impeller fastened on the axle, which is perpendicular to the liquid flow direction; there is an indicator of revolutions attached to the hub of the impeller, and in the dry chamber of the upper cover there is an electronic system, whose characteristic feature is that the indicator of revolutions of the impeller (5) constitutes at least one dampening element (71), whereas an element that detects the motion of the dampening element (71) forms an electronic system (11) emitting a stream of electromagnetic impulses by means of a coil (14), aimed in the direction of a line of revolutions of the dampening element (71).
2. Flow meter according to the claim 1, whose characteristic feature is that on the other side of the hub (6) of the impeller (5) there is attached at least one balancing element (73).
3. Flow meter according to the claim 2, whose characteristic feature is that the balancing element (73) has the dimensions of the dampening element (71).
4. Flow meter according to the claim 1, whose characteristic feature is that the indicator of revolutions of the impeller (5) constitutes a set of

dampening elements (71,72) fastened on one side of the hub (6) of the impeller (5), symmetrically to one another, on at least one theoretical line of the diameter of this hub (6) of the impeller (5).

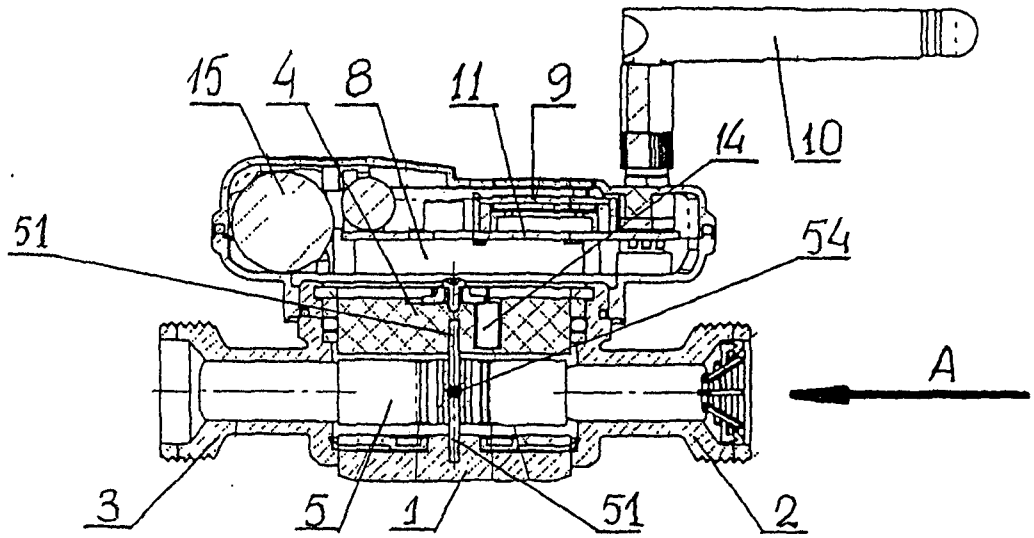
5. Flow meter according to the claim 3, whose characteristic feature is that on the other side of the impeller (5) on the hub (6) there is attached a set of balancing elements (73) with the same mass as the set of elements (71,72) forming the indicator of revolutions of the impeller (5).
6. Flow meter according to one of the claims from 1 to 5, whose characteristic feature is that on the other side of the hub (6) of the impeller (5) there is attached the balancing ring (14).
7. Flow meter according to one of the claims from 1 to 5, whose characteristic feature is that the weight of the complete impeller (5) corresponds to the weight of the liquid displaced by this impeller (5).
8. Flow meter according to one of the claims from 1 to 5, whose characteristic feature is that in the impeller (5) the center of buoyancy coincides with the center of gravity.



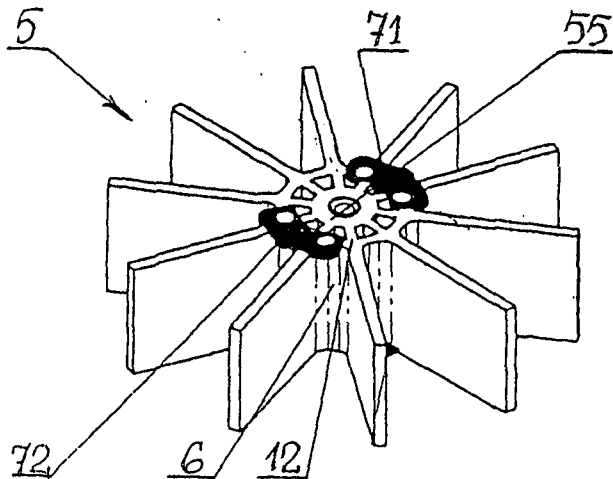
**Fig. 1**



**Fig. 2**

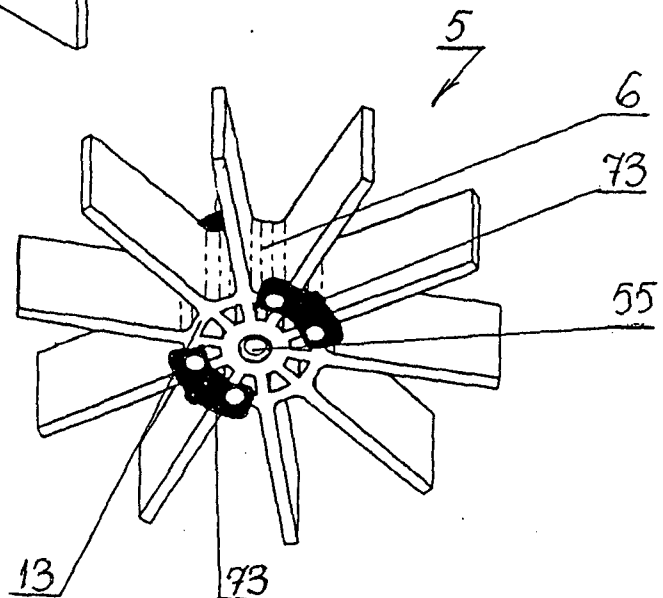


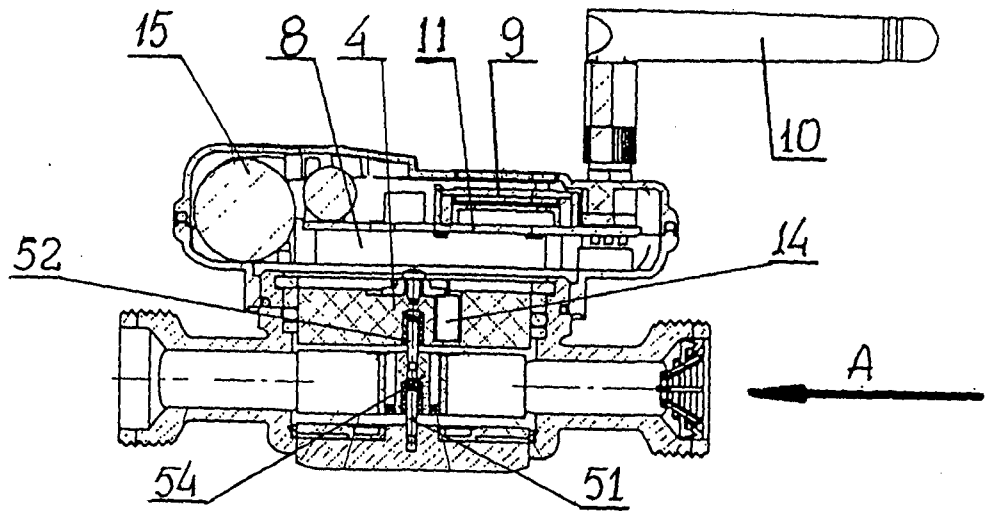
**Fig. 3**



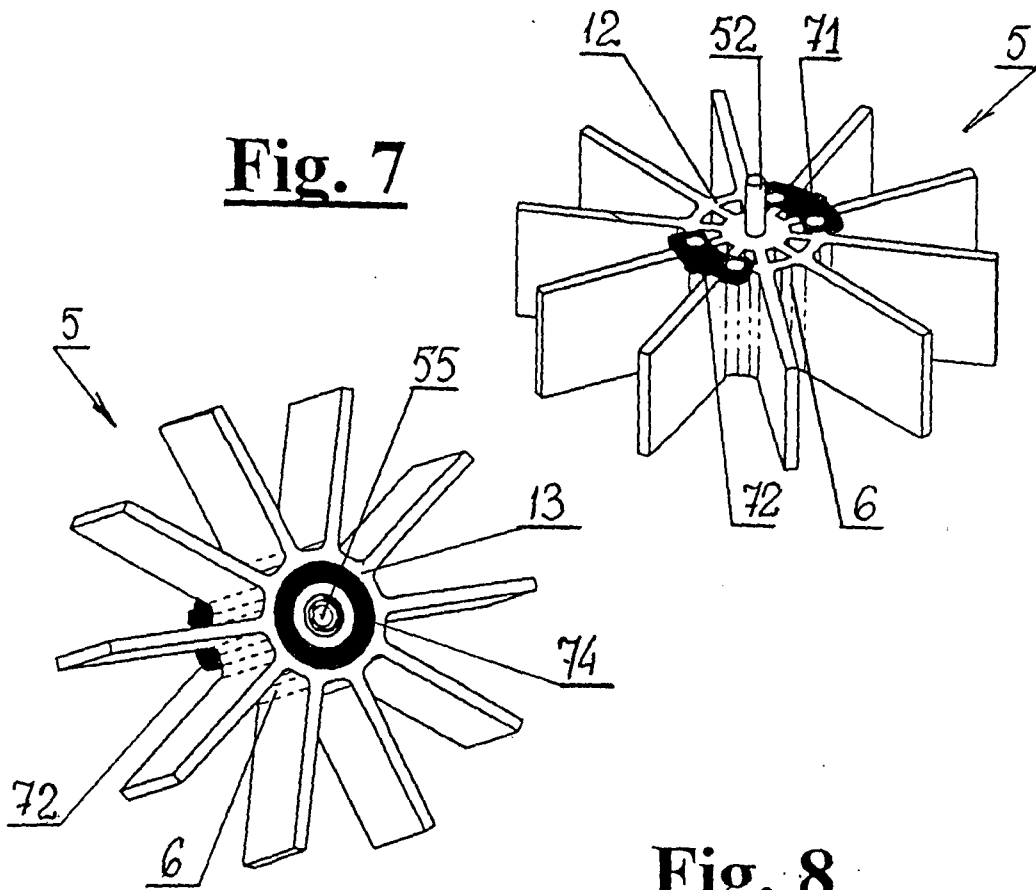
**Fig. 4**

**Fig. 5**



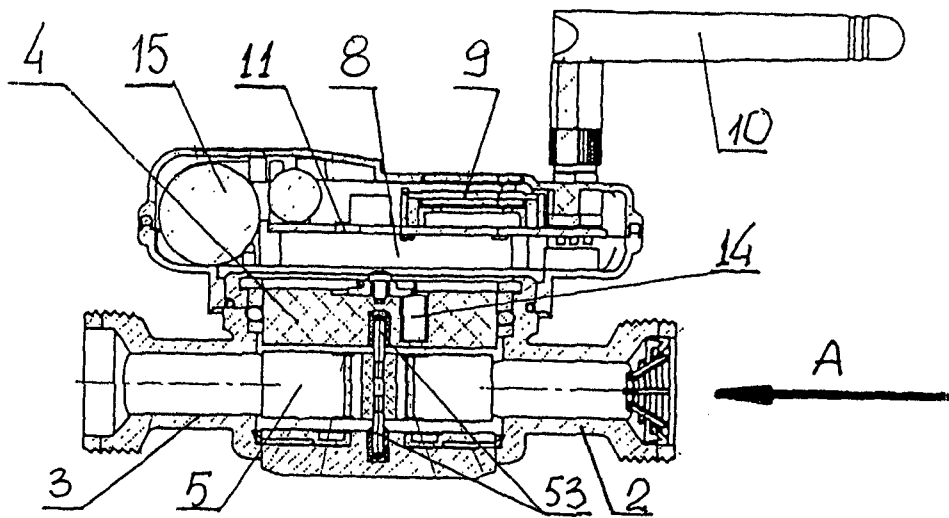


**Fig. 6**

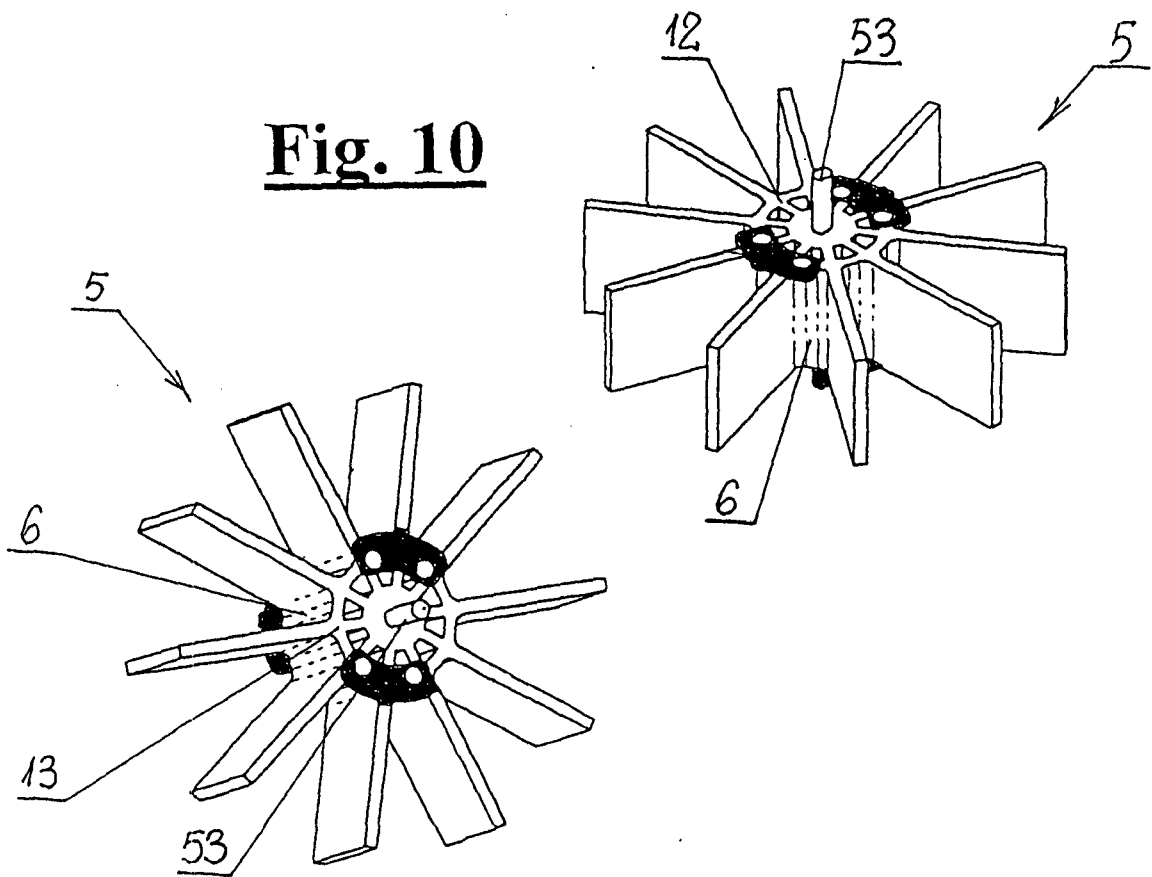


**Fig. 7**

**Fig. 8**

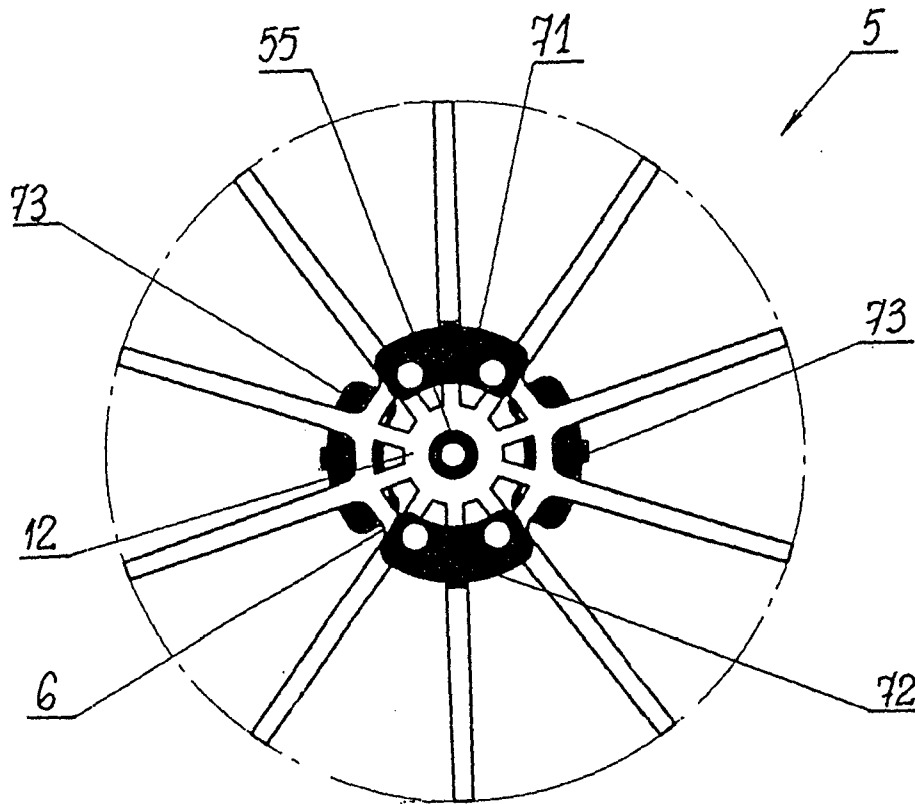


**Fig. 9**

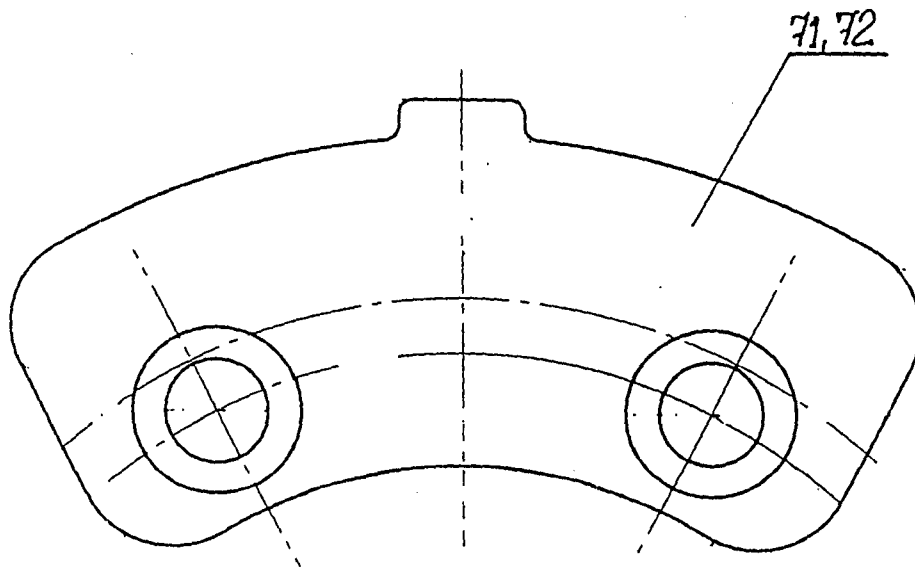


**Fig. 10**

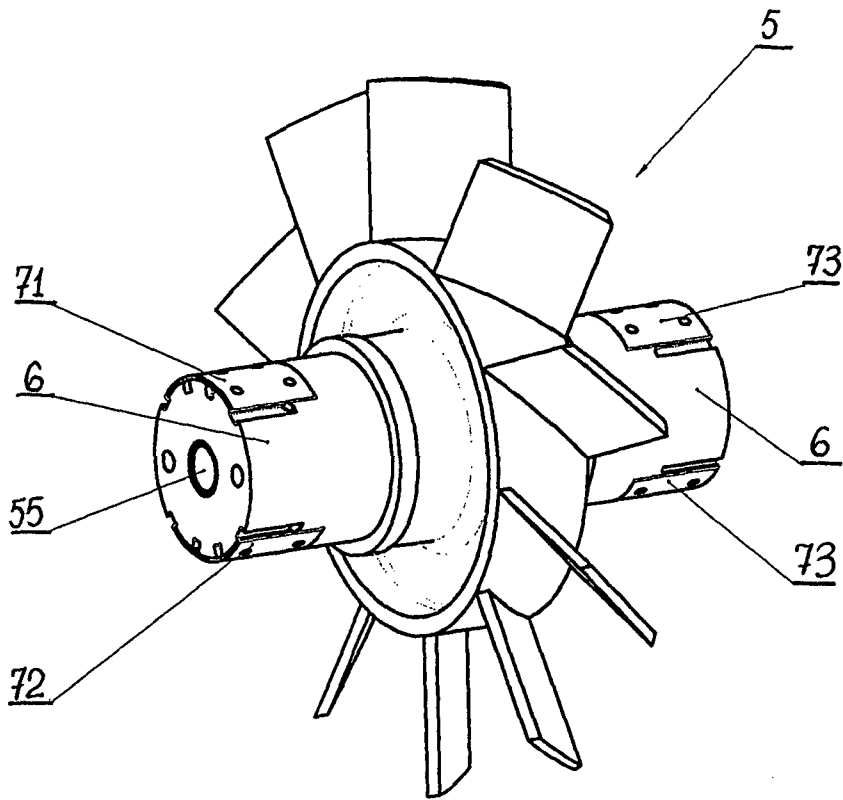
**Fig. 11**



**Fig. 12**



**Fig. 13**



**Fig. 14**

# INTERNATIONAL SEARCH REPORT

International application No PCT/PL2012/000015
---

<b>A. CLASSIFICATION OF SUBJECT MATTER</b> INV. G01F1/075 ADD.		
According to International Patent Classification (IPC) or to both national classification and IPC		
<b>B. FIELDS SEARCHED</b>		
Minimum documentation searched (classification system followed by classification symbols) G01F		
Documentation searched other than minimum documentation to the extent that such documents are included in the fields searched		
Electronic data base consulted during the international search (name of data base and, where practicable, search terms used) EPO-Internal		
<b>C. DOCUMENTS CONSIDERED TO BE RELEVANT</b>		
Category*	Citation of document, with indication, where appropriate, of the relevant passages	Relevant to claim No.
X	DE 20 2006 005400 U1 (ENGELMANN SENSOR GMBH [DE]) 10 August 2006 (2006-08-10) paragraphs [0035], [0041]; figures 1,7 paragraphs [0046], [0047] -----	1-8
X	DE 20 2006 005401 U1 (ENGELMANN SENSOR GMBH [DE]) 10 August 2006 (2006-08-10) paragraphs [0009], [0029] - [0035] -----	1-3,5-8
X	US 5 540 107 A (SILVERMAN IRA [US] ET AL) 30 July 1996 (1996-07-30) column 6, line 1 - line 42; figures 1-7 -----	1,7,8
A	US 6 149 801 A (GIORDANO EDWARD C [US] ET AL) 21 November 2000 (2000-11-21) figures 18,28 -----	2,3,5
<input type="checkbox"/> Further documents are listed in the continuation of Box C. <span style="margin-left: 100px;"><input checked="" type="checkbox"/> See patent family annex.</span>		
* Special categories of cited documents :		
"A" document defining the general state of the art which is not considered to be of particular relevance "E" earlier application or patent but published on or after the international filing date "L" document which may throw doubts on priority claim(s) or which is cited to establish the publication date of another citation or other special reason (as specified) "O" document referring to an oral disclosure, use, exhibition or other means "P" document published prior to the international filing date but later than the priority date claimed	"T" later document published after the international filing date or priority date and not in conflict with the application but cited to understand the principle or theory underlying the invention "X" document of particular relevance; the claimed invention cannot be considered novel or cannot be considered to involve an inventive step when the document is taken alone "Y" document of particular relevance; the claimed invention cannot be considered to involve an inventive step when the document is combined with one or more other such documents, such combination being obvious to a person skilled in the art "&" document member of the same patent family	
Date of the actual completion of the international search  <div style="text-align: center; font-weight: bold;">10 August 2012</div>	Date of mailing of the international search report  <div style="text-align: center; font-weight: bold;">21/08/2012</div>	
Name and mailing address of the ISA/ European Patent Office, P.B. 5818 Patentlaan 2 NL - 2280 HV Rijswijk Tel. (+31-70) 340-2040, Fax: (+31-70) 340-3016	Authorized officer  <div style="text-align: center; font-weight: bold;">Bourhis, J</div>	

# INTERNATIONAL SEARCH REPORT

Information on patent family members

International application No

PCT/PL2012/000015

Patent document cited in search report	Publication date	Patent family member(s)	Publication date
DE 202006005400 U1	10-08-2006	NONE	
-----			
DE 202006005401 U1	10-08-2006	NONE	
-----			
US 5540107	A	30-07-1996	AU 2688692 A 27-04-1993
			US 5540107 A 30-07-1996
			WO 9306439 A1 01-04-1993
-----			
US 6149801	A	21-11-2000	AT 399047 T 15-07-2008
			BR 9811872 A 15-08-2000
			CA 2308524 A1 18-02-1999
			CN 1272801 A 08-11-2000
			DK 1015090 T3 22-09-2008
			EP 1015090 A1 05-07-2000
			ES 2310008 T3 16-12-2008
			JP 2001513585 A 04-09-2001
			MX PA00001403 A 05-12-2002
			PL 338918 A1 20-11-2000
			PT 1015090 E 09-07-2008
			US 6149801 A 21-11-2000
			WO 9907456 A1 18-02-1999
-----			