

(19)



(11)

**EP 2 889 539 B1**

(12)

**EUROPEAN PATENT SPECIFICATION**

(45) Date of publication and mention  
of the grant of the patent:  
**11.01.2017 Bulletin 2017/02**

(51) Int Cl.:  
**F23N 1/00<sup>(2006.01)</sup>**

(21) Application number: **14195142.6**

(22) Date of filing: **27.11.2014**

(54) **A cooking apparatus which includes a gas tap equipped with a tactile feedback device**

Kochvorrichtung mit Gashahn mit einer Vorrichtung mit taktile Rückmeldung

Appareil de cuisson qui comprend un robinet de gaz équipé d'un dispositif de rétroaction tactile

(84) Designated Contracting States:  
**AL AT BE BG CH CY CZ DE DK EE ES FI FR GB  
GR HR HU IE IS IT LI LT LU LV MC MK MT NL NO  
PL PT RO RS SE SI SK SM TR**

(30) Priority: **24.12.2013 TR 201315150**

(43) Date of publication of application:  
**01.07.2015 Bulletin 2015/27**

(73) Proprietor: **BSH Hausgeräte GmbH  
81739 München (DE)**

(72) Inventors:  
• **Bagis, Ercan  
59510 TEKIRDAG (TR)**  
• **Ceylan, Yücel  
34500 ISTANBUL (TR)**  
• **Gönen, Ergin  
59860 TEKIRDAG (TR)**  
• **Sengün, Hakan  
59500 TEKIRDAG (TR)**

(56) References cited:  
**WO-A1-2008/114945 DE-A1- 2 101 579  
US-A- 2 138 621 US-A- 2 572 507  
US-A1- 2005 284 519**

**EP 2 889 539 B1**

Note: Within nine months of the publication of the mention of the grant of the European patent in the European Patent Bulletin, any person may give notice to the European Patent Office of opposition to that patent, in accordance with the Implementing Regulations. Notice of opposition shall not be deemed to have been filed until the opposition fee has been paid. (Art. 99(1) European Patent Convention).

## Description

**[0001]** The invention concerns cooker appliances equipped with a gas tap by which gas flow adjustment can be carried out manually between a minimum and a maximum value, especially gas hobs.

**[0002]** Gas taps used in cooking appliances have a rotating drive shaft passing through the gas tap which adjusts the gas flow, and a flow control element entry which is coupled to the shaft. The shaft is directly connected to a button on the front panel of the gas hob. The rotating of the shaft for gas flow adjustment is provided by rotating a button.

**[0003]** One of the arrangements for gas taps in the current state of the art can be seen in patent publication number EP1672279A1. A bar adapted so that it can slide axially on a level with the shaft in the gas tap forms the gas control element within a recess. One end of the bar presses on the second inner end of the shaft. A second end of the bar is in contact with a first conical surface which bears upon an inclined plane. The shaft partially enters the flow control element and is equipped with a first outer end into which a control button passes and a second inner end connected to the first end of the bar. There is a spring between the flow control element and the first end of the bar, and by means of the bar it pushes the shaft into an inactive axial position, pushing on the first outer end of the shaft.

**[0004]** Another gas tap in the current state of the art may be seen in patent publication number US2005284519. A manual gas tap for a cooking appliance is of the type with a conical adjustment entry which adjusts the gas flow. It is located in a central socket in the tap body and is coupled to a rotating drive shaft. A tap cover closes off the central socket. A transverse pin ensures the rotation of the rotating shaft to a two interval position which corresponds to the highest and lowest flows of gas, and to an intermediate locking position depending on the gas feed. The tap cover is in the form of a tubular bush shroud, and includes a gasket base with a sliding surface within a circular circlip with many notches on it. The circular circlip notches are in frictional contact with a transverse pin, thus creating a tactile and auditory effect.

**[0005]** In order that a user can easily recognize whether the fuel gas is shut off, prior art document WO 2008/114945 A1 discloses a cooking device, wherein a "click" sound occurs when the check ball is inserted into a fuel inlet.

**[0006]** A cooking appliance according to the preamble of claim 1 is disclosed in prior art document US 2 572 507 A.

**[0007]** The purpose of the invention is to provide tactile feedback in the adjustment of levels of gas flow when adjusting gas flow by rotating the gas tap of a cooker appliance. Additionally, a purpose of the invention is to provide modularity to the elements which provide tactile feedback, rendering them detachable from the gas tap.

**[0008]** The invention is a cooking appliance according to claim 1.

**[0009]** Additionally, a purpose of the invention is to provide modularity to the elements which provide tactile feedback, rendering them detachable from the gas tap.

**[0010]** In a possible embodiment of the invention, the gas tap includes an aperture formed in the tap body in order to attach the follower to the tap body. Thus, by partially attaching the follower to the tap body, support is provided from the tap body.

**[0011]** In one possible embodiment of the invention, the aperture includes threads cut into it in order to attach the follower to the tap body. Thus, the follower is attached on the tap body by rotating the threaded section into the aperture.

**[0012]** In one possible embodiment of the invention, the tactile feedback device between the tap body and the flow control element includes a guide section provided on the flow control element. Thus the follower can be operated to provide a sense of tactile feedback.

**[0013]** A guide section is formed on the flow control element. This enables the follower to act on the flow control element in a manner which provides a sense of tactile feedback.

**[0014]** The tactile feedback device includes a sleeve with a guide section, formed in such a way that it encloses a periphery of the flow control element. Thus the follower can be operated on the sleeve in a manner that provides a sense of tactile feedback.

**[0015]** The guide section includes more than one sequential depression which receive the follower. In possible embodiments of the invention, the depressions can be formed as a groove, channel or projection. Thus, as the follower enters and exits the depressions in its forward and backward movements, it provides a sense of tactile feedback.

**[0016]** In one possible embodiment of the invention, the depressions which are formed as a series are in the form of grooves. Thus, depressions are provided which the follower can enter and exit with ease.

**[0017]** In one possible embodiment of the invention, the follower includes a cylindrical element of suitable configuration permitting it to move over the depressions. In possible embodiments of the invention, the depressions take the form of a semicircular groove, a channel or a projection, and the cylindrical element of the follower will be able to move easily over the depressions.

**[0018]** In one possible embodiment of the invention, the follower includes an elastic element which permits the cylindrical element to compress and extend, and thereby move back and forth. Thus, the cylindrical element may travel a certain distance within a certain range of tolerance during level adjustment. The elastic element may be a spring or material with elastic capability.

**[0019]** In one possible embodiment of the invention, the follower includes a recessed element with a recess which

accommodates the cylindrical element and the elastic element. Support is thus provided for the cylindrical and elastic elements of the follower.

**[0020]** In one possible embodiment of the invention, threads are formed on the recessed element in order to provide attachment to the aperture on the tap body. Thus, the recessed element can be mounted on the tap body in a manner which permits it to extend through the tap body toward the flow control element.

**[0021]** In one possible embodiment of the invention, the tap body includes a recess formed on it which provides a distance gap between the tap body and a periphery of the flow control element, to accommodate a sleeve. Thus, a sleeve can be positioned within the tap body with a tolerance which permits it to turn.

**[0022]** In one possible embodiment of the invention, the sleeve includes a slot which permits a pin extending from the shaft to pass into the sleeve in order to permit the shaft to turn the flow control element together with the sleeve. The slot is formed on the periphery of an internal wall of the sleeve. This ensures that the shaft rotates the sleeve. With the rotation of the sleeve, the depressions on the guide section on the sleeve rotate in the same direction. Thus, the movement of the follower is achieved in a manner which provides sensory feedback during level adjustment of the gas.

**[0023]** In one possible embodiment of the invention, the flow control element includes a slot which permits a pin extending from the shaft to pass into the flow control element in order to permit the shaft to turn the flow control element. Thus the depressions on the guide section provided on the flow control element will also turn in the same direction and at the same time when the flow control element is rotated. With the rotating of the guide section on which the depressions are located, during level adjustment of the gas, the movement of the follower is achieved in a manner which provides sensory feedback.

Figure 1 shows a cross-section view of the assembled components of a gas tap which is the subject of the invention.

Figure 2 shows a perspective exploded view of the components of a gas tap which is the subject of the invention.

Figure 2a shows a perspective exploded view of the tactile feedback device which is the subject of the invention from the gas tap shown in Figure 1 and Figure 2.

Figure 3 is a cross-section side view of a gas tap in the current state of the art.

Figure 4 is a perspective view from the front of a cooking apparatus with a hob fitted with the gas tap which is the subject of the invention.

**[0024]** The invention concerns a cooking appliance (1) which includes a gas tap (6) equipped with a tactile feedback device (2) which provides effective perception of gas flow levels when opening a gas tap (6) and adjusting the gas.

**[0025]** Figure 4 shows a perspective view from the front of a cooking apparatus (1) fitted with the gas taps (6) which are the subject of the invention, and the buttons (5) directly connected to the gas taps (6) which control the gas tap (6) which is the subject of the invention. The button (5) or buttons (5) are fitted to a front panel (11) on an accessible front face of the carcass (10) of the cooking appliance (1). The buttons (5) are fitted to the front panel (11) of the cooking appliance (1) in a manner which permits them to turn, and are directly and co-axially connected to a shaft (60) of the gas tap (6).

**[0026]** Figure 3 is a cross-section side view of a gas tap (6) employed in the current state of the art. The gas tap (6) has a tap body (65) with an internal void. A flow control element (64) with a recess (640) is positioned within the tap body (65). An inner end of the shaft (60) which is fitted horizontally within the recess (640) in a manner which permits it to advance axially extends so that it lies within the recess (640). The shaft (60), by means of a thruster shaft (62), applies motion to a block (68) in a channel (67) formed in the tap body (65), which provides passage to the gas. The block (68), by reason of its position within the channel (67), determines the gas flow admitted from an entry (66) into the tap body (65). The end of the shaft (60) within the flow control element (64) and the thruster shaft (62) are concentrically aligned in the recess (640) within the flow control element (64). The thruster shaft (62) is a cylindrical structure with a projecting end. A spring (63) encircles the outside of an extension of the thruster shaft (62). A button (5) is fitted to the outward facing end of the shaft (60). The shaft (60) is held in such a way that it extends toward the gas tap (6) in a manner which permits it to move back and forth axially within the tap body (65) and the cover (61) which is fitted to the tap body (65). Also shown are the advancing direction D1 and the rotating direction D2 of the shaft (60). A pin (601) extends perpendicularly from the inner end of the shaft (60) within the flow control element (64). A pin (601) extending perpendicularly passes into a slot (641) formed on the flow control element (64). As the shaft (60) turns, the pin (601), bearing on the walls of the slot (641), also turns the conically shaped flow control element (64). Behind the block (68) is positioned a magnet (69) and behind the magnet (69), a thermocouple connector (70) is positioned around the magnet (69).

**[0027]** Figure 1 shows a cross section of a gas tap (6) equipped with a tactile feedback device (2) which is the subject of the invention, with the components assembled. Figure 2 shows a perspective exploded view of the components of

the gas tap (6) shown in Figure 1 which is the subject of the invention. Figure 2a shows a perspective exploded view of the tactile feedback device (2) which is the subject of the invention taken from the gas tap (6) shown in Figure 1 and Figure 2. The tactile feedback device (2) includes a guide section (644) on a flow control element (64) which rotates with the rotation of the shaft (60), and a follower (3) which provides sensation of levels as it travels on the guide section (644). A guide section (644) is fitted on a sleeve (4) which is a separate component from the gas tap (6), and can be integrated into the gas tap (6). The sleeve (4) includes depressions (41) as a guide, arranged sequentially around a periphery. During adjustment of gas flow, the follower (3) advances with a back and forward movement over the said depressions (41) on the periphery of the sleeve (4). A slot (40) cut in the intersection of the sleeve (4) permits the pin (601) on the shaft (60) to be fitted to the sleeve (4). This ensures that the pin (601), in rotating the flow control element (64), also rotates the sleeve (4). The sleeve (4) is positioned so that the slots (641, 40) coincide one above the other on a periphery (642) of the flow control element (64). At the same time, the sleeve (4) is accommodated within a recess (651) within the tap body (65).

**[0028]** The follower (3) includes an elastic element (31) and a cylindrical element (30). The sequential depressions (41) on the guide section (644) may take the form of a channel, groove or peripheral projection, which fit the shape of the cylindrical element (30) or follower (3). One end of the cylindrical element (30) extending toward the guide section (644) is semicircular in section. The follower (3) is positioned so that it extends radially toward the guide section (644) and therefore toward the periphery of the sleeve (4). The position of the follower (3) is shown in Figures 1 and 2. The follower (3) has a recessed element (32). The recessed element (32) has threads cut in a periphery. The said threads provide the attachment of the recessed element (32) to a threaded aperture (650) in the tap body (65). The follower (3), the elastic element (31) and the cylindrical element (30) are positioned within the recessed element (32). As may be seen in Figure 1, the cylindrical element (30) lies within the recessed element (32) at the level of the aperture (650) in the tap body (65).

**[0029]** There follows a more detailed account of the operation of the invention. The button (5), which is rotated in direction D1 and direction D2 when adjusting gas flow, and turning on and turning off, also turns the shaft (60) of the gas tap (6). A pin (601) on the shaft (60) also turns the flow control element (64) simultaneously with the shaft (60) and also the sleeve (4) of the tactile feedback device (2). Gas flow adjustment or turning on and turning off is provided by the flow control element (64). At the same time, the tactile feedback device (2) permits the levels of gas flow to be perceived by feedback according to the rotation of the shaft (60). To this end, a follower (3) extending radially toward the sleeve (4) and consequently toward the shaft (60), travels over depressions (41) on the sleeve (4) with the rotation of the button (5). During the said travel, the user effectively senses the level each time the follower (3) passes over the depressions (41). Thus, when the user turns the hob on, s/he is effectively in control of the gas adjustment.

**[0030]** In order to provide effective feedback perception between the levels of gas flow adjustment, the depth of each depression (41) forms approximately one radius of the circular end of the follower (3) which is in contact with the guide.

**[0031]** The follower (3) must be supported in the forward and backward movements, which may also be described as the up and down movements, of the cylindrical element (30). A recessed element (32) into which the follower (3) can be located serves this purpose. The recessed element (32) is basically a cylindrical form with one end open and the other end closed. The cylindrical element (30) is in the form of a cylindrical ball, while the elastic element (31) is a spring.

**[0032]** In alternative embodiments of the invention, the depth of the depressions (41) may become progressively deeper. Thus the user, when rotating the button (5) in direction D2, will sense increasing difficulty in rotating the button (5) as the quantity of gas changes.

**[0033]** In alternative embodiments of the invention, the situation may be reversed and the depth of the depressions (41) may be progressively made more shallow. That is, the user, when rotating the button (5) in direction D2, will feel progressively less difficulty in rotating the button (5) as the quantity of gas changes.

**[0034]** In another possible embodiment of the invention, the cylindrical element (30) of the follower (3) may be a pin, while the elastic element (31) may be an elastic material which serves to project the pin and permit it to return as required.

**[0035]** In an alternative embodiment of the invention, in order to permit the follower (3) to travel gently over the guide, the depressions (41) on the guide may take the form of a circular projection. The diameter of the depressions (41) may be smaller than the diameter of the part of the follower (3), the cylindrical element (30), for example, with which they come into contact.

**[0036]** The follower (3) may be a mechanical friction element, or a magnetic element.

**[0037]** In an alternative embodiment of the invention, the tactile feedback device (2) may include magnetic elements.

**[0038]** In an alternative embodiment of the invention, the guide section (644) is formed over the flow control element (64).

REFERENCE NUMBERS

1.	Cooking appliance	6.	Gas tap
10.	Carcass	60.	Shaft
11.	Front panel	601.	Pin

(continued)

		61.	Cover	
5	2.	Tactile feedback device	62.	Thruster shaft
	3.	Follower	63.	Spring
	30.	Cylindrical element	64.	Flow control element
	31.	Elastic element	640.	Recess
10	32.	Recessed element	641.	Slot
			642.	Periphery
	4.	Sleeve	643.	Aperture
	40.	Slot	644.	Guide section
	41.	Depression		
15	5.	Button	65.	Tap body
			650.	Aperture
			651.	Recess
	D1:	Advance direction	66.	Entry
20	D2:	Return direction	67.	Channel
			68.	Block
			69.	Magnet
			70.	Thermocouple connector

## Claims

- 25
- 30
- 35
- 40
- 45
- 50
- 55
1. A cooking appliance (1) which comprises a carcass (10), a front panel (11) on the carcass (10), a button (5) on the front panel (11), a gas tap (6) which has a tap body (65) with a hollow interior in which a flow control element (64) is accommodated, said flow control element (64) which regulates the flow of gas by turning a shaft (60) is connected to the button (5), wherein the cooking appliance (1) includes a tactile feedback device (2), **characterized in that**, said device includes a follower (3) configured to extend radially from the tap body (65) toward the flow control element (64) in order to provide adjustment of gas adjustment levels in a tactile manner while the button (5) is rotating, wherein said device includes a guide section (644), which is fitted on a sleeve (4), said sleeve (4) is formed in such a way that it encloses a periphery (642) of the flow control element (64) and said sleeve (4) includes depressions as a guide arranged sequentially around a periphery, said depressions receive the follower (3).
  2. The cooking appliance (1) as claimed in claim 1, **characterized in that** the gas tap (6) includes an aperture (650) formed in the tap body (65) in order to attach a follower (3) to the tap body (65).
  3. The cooking apparatus (1) as claimed in claim 2, **characterized in that** the aperture (650) includes threads cut into it in order to attach the follower (3) to the tap body (65).
  4. The cooking apparatus (1) as claimed in any one of the above claims, **characterized in that** the depressions (41) which are formed as a series are each in the form of a groove.
  5. The cooking apparatus (1) as claimed in any one of the above claims, **characterized in that** the follower (3) includes a cylindrical element (30) in a suitable form that permits it to travel over the depressions (41).
  6. The cooking apparatus (1) as claimed in claim 5, **characterized in that** the follower (3) includes an elastic element (31) which permits the cylindrical element (30) to compress and extend, and thereby move back and forth.
  7. The cooking apparatus (1) as claimed in claim 6, **characterized in that** the follower (3) includes a recessed element (32) with a recess in which the cylindrical element (30) and the elastic element (31) are positioned.
  8. The cooking apparatus (1) as claimed in claim 7, **characterized in that** the recessed element (32) includes threads so that it can be fitted to the aperture (650) on the tap body (65).
  9. 11. The cooking apparatus (1) as claimed in any one of the above claims, **characterized in that** the tap body (65)

includes a recess (651) which provides a distance gap between the tap body (65) and a periphery (642) of the flow control element (64) to accommodate the sleeve (4).

5 10. The cooking apparatus (1) as claimed in any one of the above claims, **characterized in that** the sleeve (4) includes a slot (40) which permits a pin (601) extending from the shaft (60) to pass into the sleeve (4) in order to ensure that the flow control element (64) and the sleeve (4) are rotated together by the shaft (60).

10 11. The cooking apparatus (1) as claimed in any one of the above claims, **characterized in that** the flow control element (64) includes a slot (641) which permits the shaft's (60) pin (601) to pass into the flow control element (64) in order to ensure that shaft (60) rotates the flow control element (64).

### Patentansprüche

15 1. Kochvorrichtung (1), welche einen Korpus (10), eine Frontblende (11) an dem Korpus (10), einen Knopf (5) auf der Frontblende (11) und einen Gashahn (6), welcher einen Hahnkörper (65) mit einem hohlen Inneren aufweist, in welchem ein Durchflussregelelement (64) aufgenommen ist, umfasst, wobei das Durchflussregelelement (64), welches den Durchfluss von Gas durch Drehen einer Welle (60) regelt, mit dem Knopf (5) verbunden ist, wobei die  
20 Kochvorrichtung (1) eine Vorrichtung mit taktile Rückmeldung (2) aufweist, **dadurch gekennzeichnet, dass** die Vorrichtung einen Folger (3) aufweist, der so gestaltet ist, dass er sich von dem Hahnkörper (65) aus radial zu dem Durchflussregelelement (64) hin erstreckt, um eine Einstellung von Gaseinstellpegeln auf eine taktile Weise zu gewährleisten, während der Knopf (5) sich dreht, wobei die Vorrichtung einen Führungsabschnitt (644) aufweist, welcher auf einer Hülse (4) angebracht ist, wobei diese Hülse (4) derart ausgebildet ist, dass sie einen Umfang (642) des Durchflussregelements (64) umschließt, und diese Hülse (4) als eine Führung dienende Vertiefungen  
25 aufweist, die hintereinander um einen Umfang herum angeordnet sind, wobei diese Vertiefungen den Folger (3) aufnehmen.

30 2. Kochvorrichtung (1) nach Anspruch 1, **dadurch gekennzeichnet, dass** der Gashahn (6) eine in dem Hahnkörper (65) ausgebildete Öffnung (650) aufweist, um einen Folger (3) an dem Hahnkörper (65) zu befestigen.

3. Kochvorrichtung (1) nach Anspruch 2, **dadurch gekennzeichnet, dass** die Öffnung (650) in sie eingeschnittene Gewindegänge aufweist, um den Folger (3) an dem Hahnkörper (65) zu befestigen.

35 4. Kochvorrichtung (1) nach einem der obigen Ansprüche, **dadurch gekennzeichnet, dass** die Vertiefungen (41), welche als eine Reihe ausgebildet sind, jeweils die Form einer Rille haben.

40 5. Kochvorrichtung (1) nach einem der obigen Ansprüche, **dadurch gekennzeichnet, dass** der Folger (3) ein zylindrisches Element (30) in einer geeigneten Form aufweist, welche ihm ermöglicht, sich über die Vertiefungen (41) hinweg zu bewegen.

6. Kochvorrichtung (1) nach Anspruch 5, **dadurch gekennzeichnet, dass** der Folger (3) ein elastisches Element (31) aufweist, welches ermöglicht, dass das zylindrische Element (30) zusammengedrückt wird und sich ausdehnt und sich dadurch vor und zurück bewegt.

45 7. Kochvorrichtung (1) nach Anspruch 6, **dadurch gekennzeichnet, dass** der Folger (3) ein ausgespartes Element (32) mit einer Aussparung aufweist, in welcher das zylindrische Element (30) und das elastische Element (31) positioniert sind.

50 8. Kochvorrichtung (1) nach Anspruch 7, **dadurch gekennzeichnet, dass** das ausgesparte Element (32) Gewindegänge aufweist, sodass es in der Öffnung (650) in dem Hahnkörper (65) angebracht werden kann.

55 9. Kochvorrichtung (1) nach einem der obigen Ansprüche, **dadurch gekennzeichnet, dass** der Hahnkörper (65) eine Aussparung (651) aufweist, welche einen Abstandspalt zwischen dem Hahnkörper (65) und einem Umfang (642) des Durchflussregelements (64) bereitstellt, um die Hülse (4) aufzunehmen.

10. Kochvorrichtung (1) nach einem der obigen Ansprüche, **dadurch gekennzeichnet, dass** die Hülse (4) einen Schlitz (40) aufweist, welcher ermöglicht, dass ein Stift (601), der sich von der Welle (60) aus erstreckt, in die Hülse (4) eingreift, um sicherzustellen, dass das Durchflussregelelement (64) und die Hülse (4) durch die Welle (60) zusammen

gedreht werden.

- 5 11. Kochvorrichtung (1) nach einem der obigen Ansprüche, **dadurch gekennzeichnet, dass** das Durchflussregelelement (64) einen Schlitz (641) aufweist, welcher ermöglicht, dass der Stift (601) der Welle (60) in das Durchflussregelelement (64) eingreift, um sicherzustellen, dass die Welle (60) das Durchflussregelelement (64) dreht.

## Revendications

- 10 1. Appareil de cuisson (1) qui comprend une carcasse (10), un panneau avant (11) sur la carcasse (10), un bouton (5) sur le panneau avant (11), un brûleur à gaz (6) qui a un corps (65) de brûleur avec un intérieur creux dans lequel un élément (64) de contrôle de débit est reçu, ledit élément (64) de contrôle de débit qui régule le débit de gaz en tournant un axe (60) est connecté au bouton (5), dans lequel l'appareil de cuisson (1) inclut un dispositif tactile de rétroaction (2), **caractérisé en ce que** ledit dispositif inclut un doigt (3) configuré pour s'étendre radialement depuis  
15 le corps (65) de brûleur vers l'élément (64) de contrôle de débit afin de fournir un ajustement de niveaux d'ajustement de gaz d'une manière tactile tandis que le bouton (5) tourne, dans lequel ledit dispositif inclut une section de guidage (644), qui est disposée sur une gaine (4), ladite gaine (4) est formée de telle manière qu'elle renferme une périphérie (642) de l'élément (64) de contrôle de débit et ladite gaine (4) inclut des dépressions comme un guide agencées séquentiellement autour d'une périphérie, lesdites dépressions reçoivent le doigt (3).
- 20 2. Appareil de cuisson (1) selon la revendication 1, **caractérisé en ce que** le brûleur à gaz (6) inclut une ouverture (650) formée dans le corps (65) de brûleur afin de fixer un doigt (3) au corps (65) de brûleur.
- 25 3. Appareil de cuisson (1) selon la revendication 2, **caractérisé en ce que** l'ouverture (650) inclut des filets découpés dans celle-ci afin de fixer le doigt (3) au corps (65) de brûleur.
- 30 4. Appareil de cuisson (1) selon l'une quelconque des revendications ci-dessus, **caractérisé en ce que** les dépressions (41) qui sont formées comme une série sont chacune sous la forme d'une rainure.
- 35 5. Appareil de cuisson (1) selon l'une quelconque des revendications ci-dessus, **caractérisé en ce que** le doigt (3) inclut un élément cylindrique (30) sous une forme appropriée qui lui permet de se déplacer par-dessus les dépressions (41).
6. Appareil de cuisson (1) selon la revendication 5, **caractérisé en ce que** le doigt (3) inclut un élément élastique (31) qui permet que l'élément cylindrique (30) se comprime et s'étende, et ainsi se déplace en arrière et en avant.
7. Appareil de cuisson (1) selon la revendication 6, **caractérisé en ce que** le doigt (3) inclut un élément en renforcement (32) avec un renforcement dans lequel l'élément cylindrique (30) et l'élément élastique (31) sont positionnés.
- 40 8. Appareil de cuisson (1) selon la revendication 7, **caractérisé en ce que** l'élément en renforcement (32) inclut des filets de telle sorte qu'il peut être disposé sur l'ouverture (650) sur le corps (65) de brûleur.
- 45 9. Appareil de cuisson (1) selon l'une quelconque des revendications ci-dessus, **caractérisé en ce que** le corps (65) de brûleur inclut un renforcement (651) qui fournit un espace de distance entre le corps (65) de brûleur et une périphérie (642) de l'élément (64) de contrôle de débit pour recevoir la gaine (4).
- 50 10. Appareil de cuisson (1) selon l'une quelconque des revendications ci-dessus, **caractérisé en ce que** la gaine (4) inclut une fente (40) qui permet qu'un ergot (601) s'étendant depuis l'axe (60) passe dans la gaine (4) afin d'assurer que l'élément (64) de contrôle de débit et la gaine (4) soient mis à tourner ensemble par l'axe (60).
- 55 11. Appareil de cuisson (1) selon l'une quelconque des revendications ci-dessus, **caractérisé en ce que** l'élément (64) de contrôle de débit inclut une fente (641) qui permet que l'ergot (601) de l'axe (60) passe dans l'élément (64) de contrôle de débit afin d'assurer que l'axe (60) fasse tourner l'élément (64) de contrôle de débit.

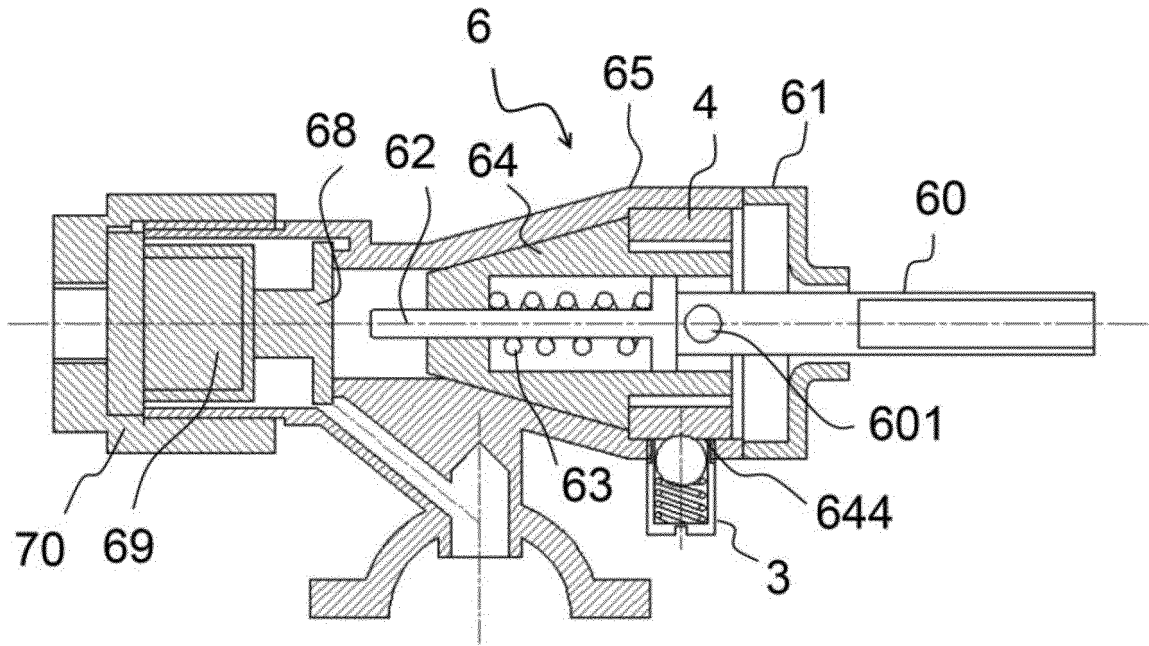

Figure 1

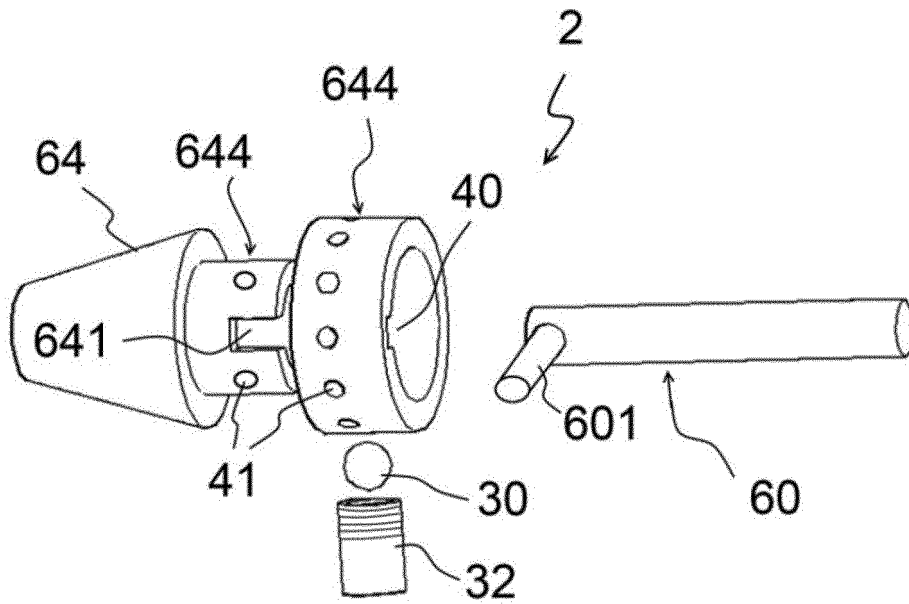

Figure 2a

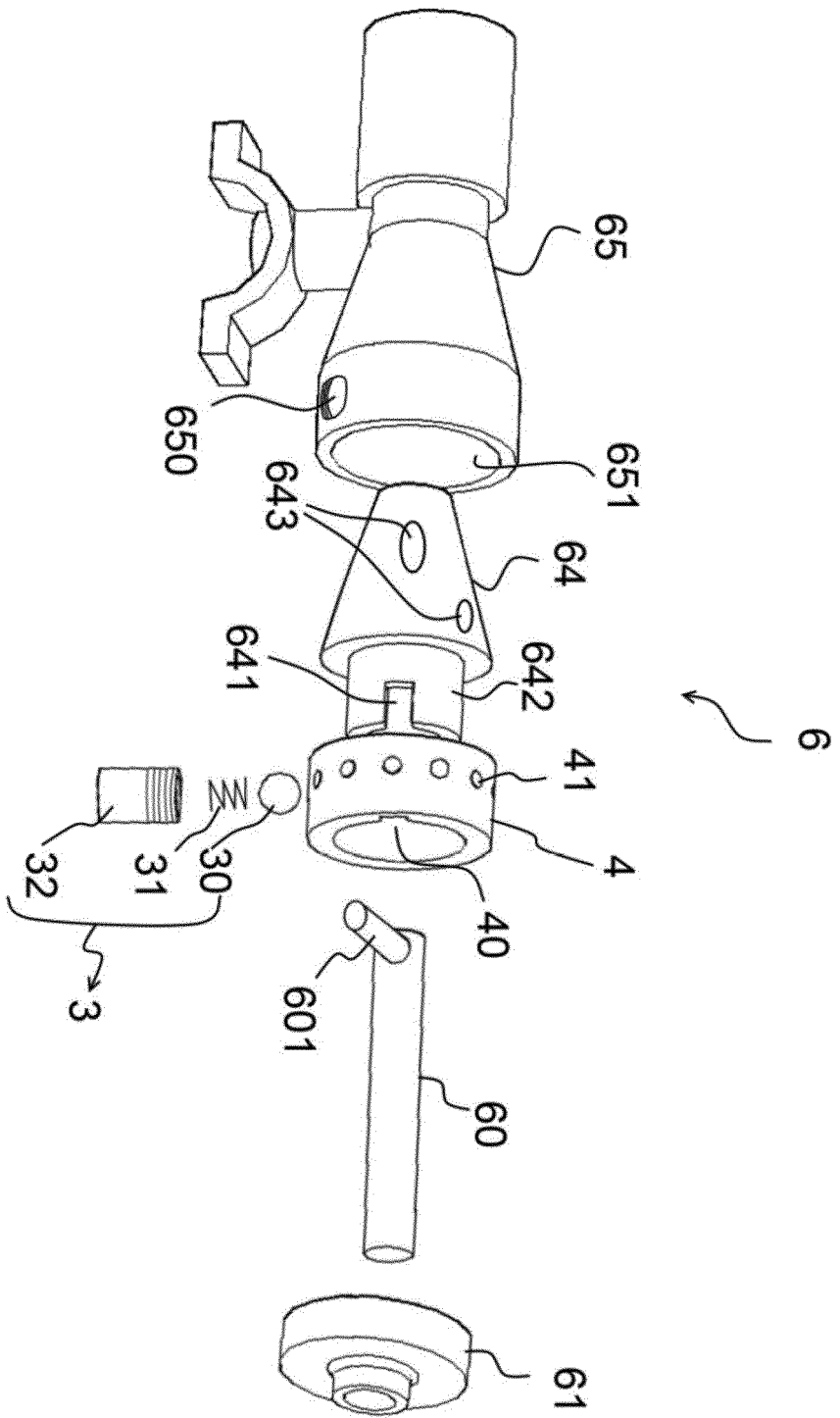

Figure 2

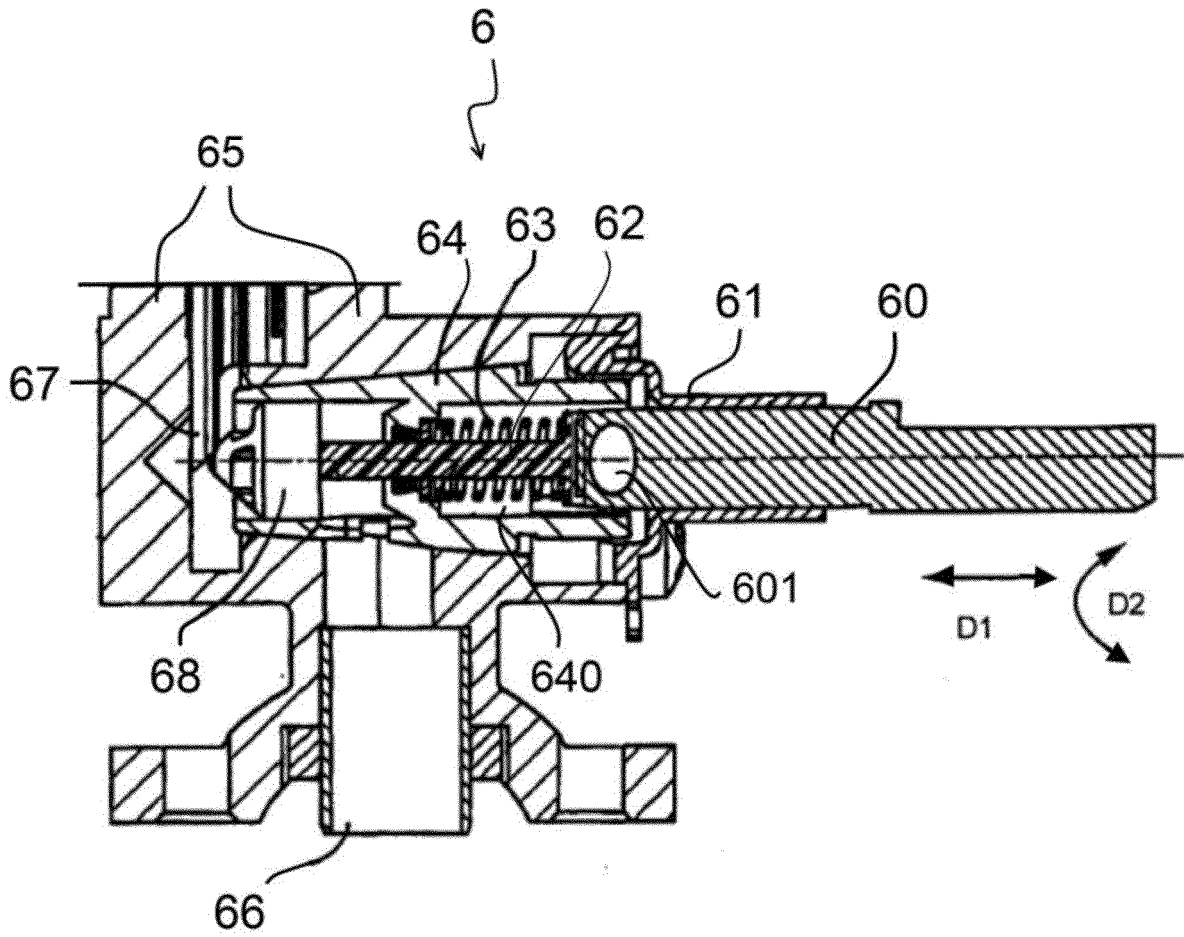

Figure 3

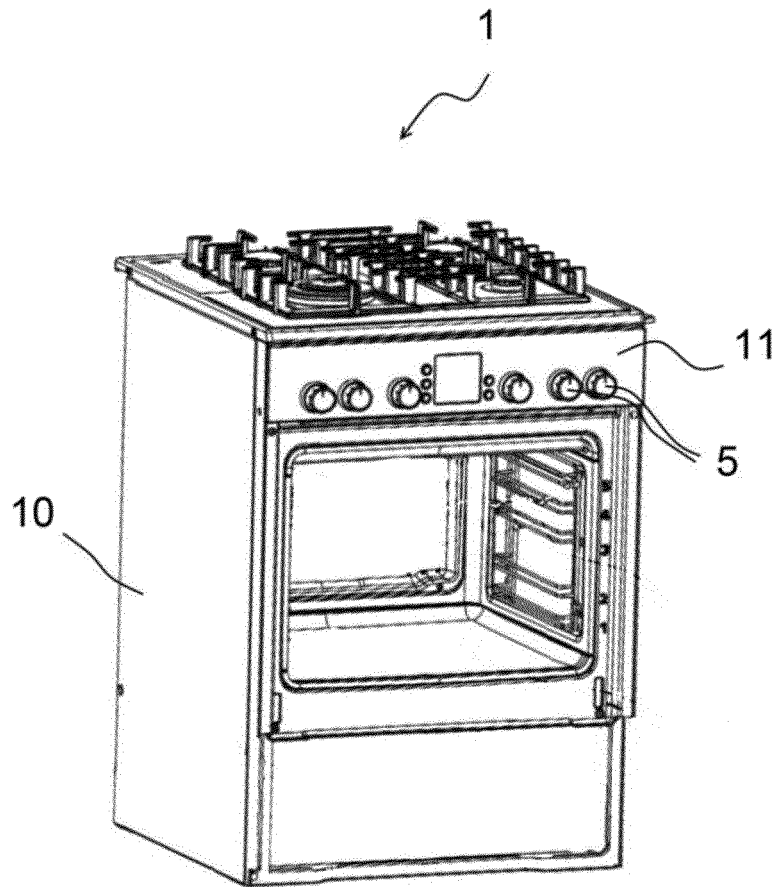

Figure 4

**REFERENCES CITED IN THE DESCRIPTION**

*This list of references cited by the applicant is for the reader's convenience only. It does not form part of the European patent document. Even though great care has been taken in compiling the references, errors or omissions cannot be excluded and the EPO disclaims all liability in this regard.*

**Patent documents cited in the description**

- EP 1672279 A1 [0003]
- US 2005284519 A [0004]
- WO 2008114945 A1 [0005]
- US 2572507 A [0006]