

(No Model.)

3 Sheets—Sheet 1.

J. POYSER.  
LOOM.

No. 568,275.

Patented Sept. 22, 1896.

Fig. 1.

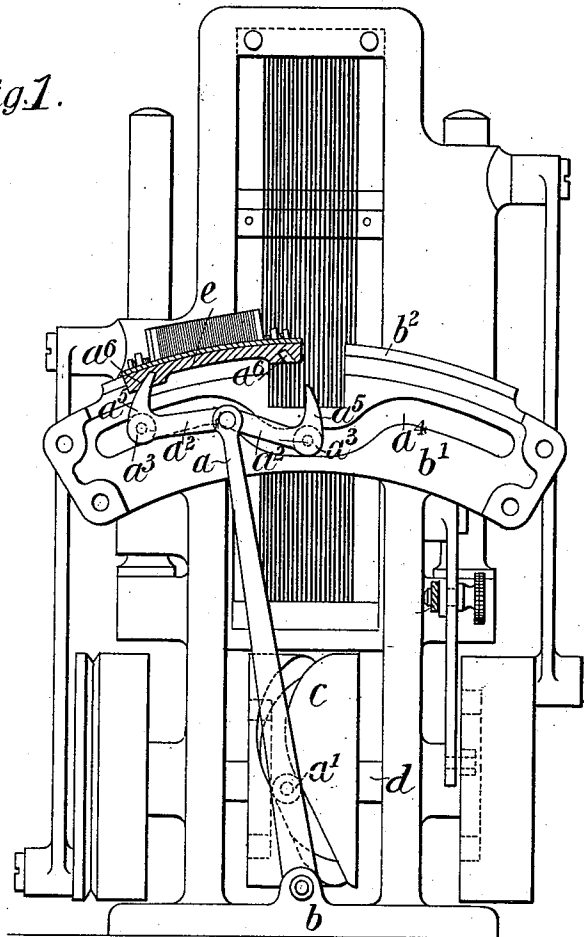

Witnesses  
*Malcolm Macdonald*  
*F. L. Middleton*

Inventor  
*John Poyser*  
by *Fetherstonhaugh*  
*Attys*

(No Model.)

3 Sheets—Sheet 2.

J. POYSER.  
LOOM.

No. 568,275.

Patented Sept. 22, 1896.

Fig. 2.

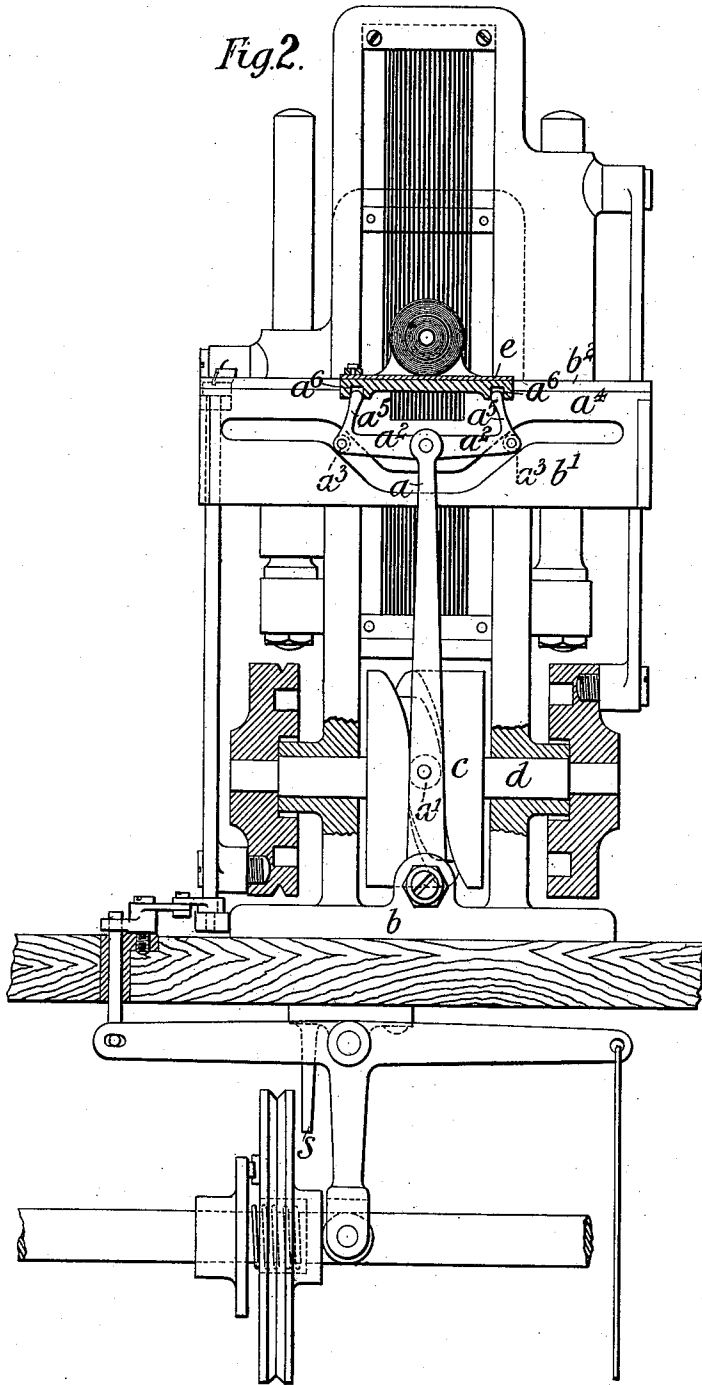

Witnesses  
*Charles W. ...*  
*F. L. Middleton*

Inventor  
*John Poyser*  
 by *Fisher & ...*

(No Model.)

J. POYSER.  
LOOM.

3 Sheets—Sheet 3.

No. 568,275.

Patented Sept. 22, 1896.

*Fig. 3.*

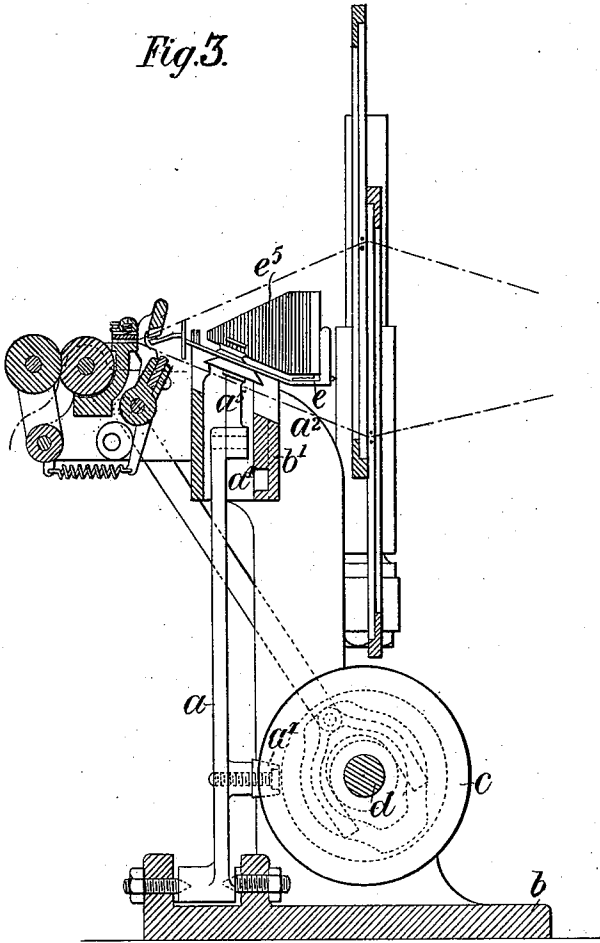

*Witnesses.*  
*Walter Waldson*  
*J. L. Middleton*

*Inventor.*  
*John Poyser*  
*by F. H. Sturtevant*

# UNITED STATES PATENT OFFICE.

JOHN POYSER, OF MANSFIELD, ENGLAND.

## LOOM.

SPECIFICATION forming part of Letters Patent No. 568,275, dated September 22, 1896.

Application filed August 5, 1895. Serial No. 558,251. (No model.) Patented in England January 2, 1895, No. 144; in France July 25, 1895, No. 249,170; in Belgium July 25, 1895, No. 116,704; in Italy September 30, 1895, XXX, 39,439, LXXVII, 227; in Spain October 12, 1895, No. 17,785; in Austria November 21, 1895, No. 45/4,406, and in India November 23, 1895, No. 261.

To all whom it may concern:

Be it known that I, JOHN POYSER, a subject of the Queen of Great Britain, residing at Mansfield, England, have invented new and useful Improvements in Looms, (for which patents have been granted to me in Great Britain, No. 144, dated January 2, 1895, and in India, No. 261, dated November 23, 1895, and to myself jointly with James Haywood and Francis Edward Dyke Acland in France, No. 249,170, dated July 25, 1895; in Belgium, No. 116,704, dated July 25, 1895; in Italy, Vol. XXX, No. 39,439, Vol. LXXVII, No. 227, dated September 30, 1895; in Spain, No. 17,785, dated October 12, 1895, and in Austria, No. 45/4,406, dated November 21, 1895,) of which the following is a specification.

This invention relates to looms for weaving and chiefly to high-speed looms of the kind described in the specification of former Letters Patent No. 547,130, dated October 1, 1895; and it consists in providing improved means for operating the shuttle.

In the accompanying drawings, Figure 1 is a sectional front elevation of one form of high-speed loom for weaving provided with my improved means for operating the shuttle. Figs. 2 and 3 are respectively a front sectional elevation and a partial side sectional elevation of another form of high-speed loom provided with my improvements.

Similar reference-letters indicate corresponding parts throughout the drawings.

According to the present invention a single picker-lever  $a$ , Figs. 1, 2, and 3, is provided pivoted to the base  $b$  of the loom and having a roller  $a'$  (or projection) engaging in the groove of a cam  $c$  upon the driving-shaft  $d$ , so that as the said shaft revolves the lever vibrates upon its pivot. To the upper or free end of the picker-lever  $a$  are pivoted two radial pickers  $a^2 a^3$ , each of which is provided at its free end with a roller  $a^3$ , (or projection,) adapted to engage in a cam slot or groove  $a^4$ , formed in the frame  $b'$  of the loom or in an independent plate attached to the loom. The pickers are each provided with a tooth  $a^5$ , projecting upward between the sides  $b^2 b^3$  of the shuttle-race and adapted to engage in a recess  $a^6$  in the shuttle  $e$  when the picker is raised by the action of the cam-

slot  $a^4$  upon the roller  $a^3$  (or projection) and to be clear of the warp-threads when lowered by the same, and the cam-slot  $a^4$  is so arranged that the teeth of the pickers engage alternately with the shuttle, each picker being raised into engagement before the other is lowered out of engagement, so that the shuttle is passed backward and forward through the shed in a positive manner when the picker-lever is vibrated by the cam  $c$ .

Fig. 1 illustrates a loom having a curved shuttle-race, the curve being the arc of a circle described from the center of the pivot of the lever  $a$ , while Figs. 2 and 3 illustrate a loom having a straight shuttle-race.

Having now particularly described and ascertained the nature of my said invention and in what manner the same is to be performed, I declare that what I claim is—

1. In combination, in a loom, the frame having a cam-slot therein, the shuttle, the pivoted lever  $a$  with means for oscillating the same, a pair of pickers at the free end of the lever, each picker having a projecting tooth and guiding means consisting of the rollers and said cam-slot for giving the pickers with their teeth movement toward and from the shuttle, both of said pickers being pivotally connected at one common point, to the free end of the rocking lever, one extending radially to the one side of the lever from its pivotal connection and the other extending radially in the opposite direction from the pivotal connection, substantially as described.

2. In combination, in a loom, the main swinging lever with operating means therefor, a pair of pickers pivoted at the free end of the lever and swinging in the same plane with the oscillation of the main lever, the frame having the guiding-slot therein arranged laterally of and along the face of the pivoted pickers and the rollers projecting laterally from the pickers into the said guide-slot, the said pickers extending radially from the free end of the swinging lever in opposite directions.

JOHN POYSER.

Witnesses:

G. F. REDFERN,  
JOHN E. BOUSFIELD.