

March 23, 1937.

H. M. DOWSETT ET AL

2,074,831

THERMIONIC VALVE CIRCUIT ARRANGEMENT

Filed May 25, 1934

2 Sheets-Sheet 1

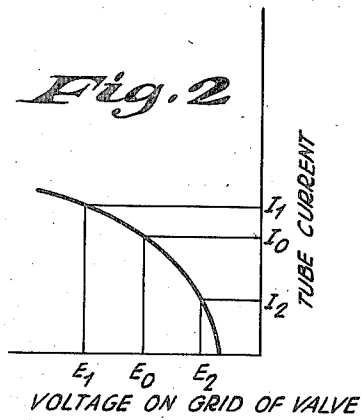
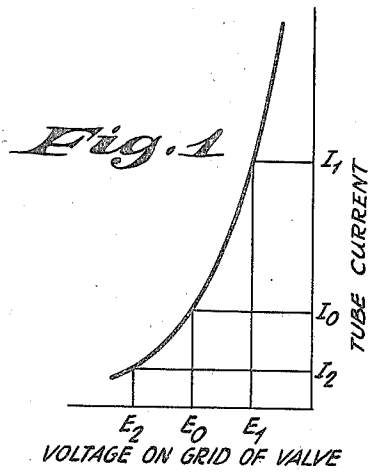

Fig. 3

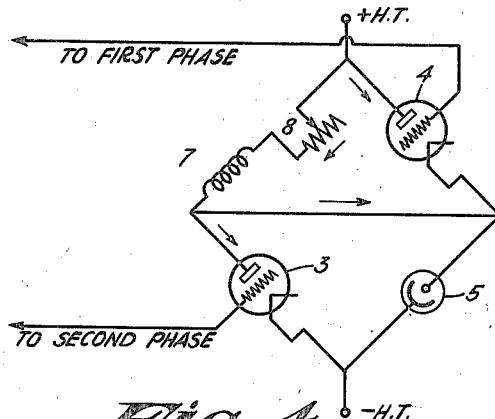
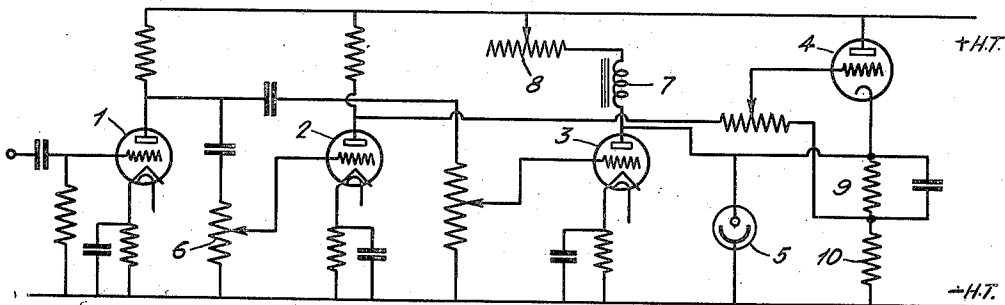

Fig. 4



INVENTOR
HARRY M. DOWSETT
ERNEST F. GORDENOUGH
BY *H.S. novel*
ATTORNEY

UNITED STATES PATENT OFFICE

2,074,831

THERMIONIC VALVE CIRCUIT ARRANGEMENT

Harry Melville Dowsett and Ernest Frederick Goodenough, London, England, assignors to Radio Corporation of America, a corporation of Delaware

Application May 25, 1934, Serial No. 727,446
In Great Britain April 24, 1933

3 Claims. (Cl. 179—171)

This invention relates to thermionic valve circuit arrangements and more particularly to circuit arrangements wherein a load is driven or energized from a thermionic valve, said load being
5 of such impedance as not to "match" the said valve.

More specifically, though not exclusively, the invention relates to arrangements suitable for use in television and other facsimile receivers
10 wherein a load device constituted by a neon or other electric glow discharge tube is energized from a valve, the light from said tube being employed to reproduce in any manner well known per se, a television or other picture.

Although as above stated, the invention is not limited to arrangements involving neon or similar electric glow discharge tubes, the said invention will be particularly described with reference to its application to such arrangements since it is
15 primarily designed for use in connection with such arrangements.

At the present time it is usual in television and like receivers to operate a picture building neon or like tube by means of a thermionic valve, to
25 whose grid circuit the television signals are fed, said tube being either in series or in parallel with said valve. For example in one well known arrangement a neon tube is connected in series with a source of anode potential between the
30 anode and cathode of a thermionic valve to whose grid circuit the television or other signals are applied. This is a series arrangement. In another well known arrangement—the parallel arrangement—a neon or like tube is directly con-
35 nected between the anode and cathode of the valve to whose grid circuit the television or other signal potentials are applied, the anode of said valve being connected to the positive terminal of a source of anode potential through a choke in series with a resistance.

Figures 1 and 2 are curves indicating the distortion that results from the use of a glow discharge tube in the output circuit of a valve.

Figure 3 shows schematically an arrangement
45 for correcting this distortion.

Figures 4-7 show more conventional circuits for accomplishing the result of Figure 3.

Now in general the impedance of a neon or similar electric glow discharge tube, such as can be employed for picture reproduction is very different from that which would be necessary to
50 "match" the impedance of an ordinary thermionic valve, the said tube impedance being generally much lower than that of a valve. For

example, the impedance of a so-called "crater" neon tube may be taken to be, in general, of the order of 200 ohms. As a result of this fact, more or less series distortion occurs when either the series or the parallel arrangement hereinbefore
5 described is employed. The nature of this distortion will be readily appreciated from Figures 1 and 2 of the drawings, Figure 1 being a graph connecting tube current (ordinates) with voltage applied to the grid of the valve (abscissae) when the tube and valve are in series arrangement
10 hereinbefore described. Similarly Figure 2 of the drawings is a corresponding graph of the results obtained with the parallel arrangement, tube current (ordinates) being again plotted against grid voltage (abscissae). In both the said Figures 1 and 2, E_0 and I_0 are respectively the normal mean potential on the grid of the valve and the resultant current through the tube and it will be seen that the current change (I_0 to I_2) obtained for a grid voltage swing from E_0 to E_2 is quite
15 different from the current change (I_0 to I_1) obtained when a grid voltage swing of like magnitude but in the other direction takes place between the valve E_0 and E_1 . In the series case the current change for a grid voltage change
20 E_0 — E_1 is considerably greater than the current change for a grid voltage swing E_0 — E_2 while in the parallel case a distorting effect which is opposite in nature occurs i. e. the current change for a grid voltage swing E_0 — E_1 is considerably
25 less than the current change for a grid voltage swing E_0 — E_2 .

The present invention has for its object to avoid the forms of distortion above referred to and this
35 object is achieved by employing a composite arrangement which may be regarded as consisting of series and parallel arrangements in combination and which is such that the distorting effect due to the series feature of the arrangement is
40 substantially annulled or off-set by the distorting effect due to the parallel feature of the said arrangement.

According to this invention, a load device is fed by the parallel method from one valve and by
45 the series method from another and the signal or other voltages applied to the grids of these valves are arranged to be in opposite phase.

The invention is illustrated in and further explained in connection with Figures 3 to 7 of the
50 accompanying drawings.

Referring first to Figures 3 and 4 a neon or other glow discharge tube 5, employed for example as a reproducing device in a television or
55

other receiver, is connected in series with a thermionic valve 4 and also in parallel with a thermionic valve 3 the parallel feed being obtained in manner well known per se, by means of a choke 7 and resistance 8 connected in series with one another between the anode of the valve 3 and the positive terminal +HT of the common driving source of anode potential. Resistances 9 and 10 (see Fig. 4) are connected across the tube 5. The resistance 9 serves to bias the valve 4. Input signals, for example television signals, are applied to the grid of a valve 1 whose anode is coupled as illustrated to the grids of thermionic valves 2 and 3. Of these two valves the valve 2 reverses the phase of the signals and applies its output, as illustrated, to the grid of the valve 4 while the valve 3 is, as above described, a parallel feeding valve. By variation of the grid bias applied to the valves 3 and 4 and by varying the resistance 8 above referred to, the anode current of the said valves 3 and 4 as well as the current through the tube 5 may be adjusted to desired values. Since, as above stated, the purpose of the valve 2 is principally to reverse the phase of the signal, the signal input to the grid of this valve may, if desired, be initially attenuated by adjusting a potentiometer 6 associated as shown with the grid circuit of the said valve 2.

Figure 3 of the drawings is a theoretical diagram representing the arrangement which is shown in a more conventional manner in Figure 4, the parts in Figure 4 being indicated by the same reference numerals as are employed in Figure 3 and the arrows in Figure 3 indicating the directions of the steady currents. It will be obvious from Figures 3 and 4 that the picture may be reversed from positive to negative or vice versa by reversing the grids of the valves 3 and 4. In Figure 3 the lead from the grid of the valve 4 is marked "to first phase" and the lead from the grid of the valve 3 is marked "to second phase" in order to indicate the phase reversal which is effected.

Instead of employing an additional valve for phase reversal i. e. for securing the necessary phase difference between the signals applied to the grids of the valves 3 and 4, transformers may be employed. Two such arrangements are shown in Figures 5 and 6 of the drawings. In the said Figure 5 a transformer 11 is employed and its secondary is so connected that the picture signal is impressed on the grid of the valve 4 in opposite phase from the signal impressed on the grid of the valve 3 while in the said Figure 6 the desired result is achieved by employing a transformer 12 having two secondary windings as shown, one winding feeding the valve 3 and the other feeding the valve 4 so as to secure the desired reversal of phase.

The arrangement shown in Figure 7 of the drawings is a modification of the arrangement

shown in Figure 4. In the accompanying drawings valves 3' and 4' connected in series are employed and a choke 7' and resistance 8' which are connected in series with one another and with the neon tube 5 are isolated, as regards direct current, by means of a condenser 11'. The resistance 9' provides grid bias for the valve 4'.

We claim:—

1. In a television, facsimile or the like receiver, a glow discharge device, a space discharge device provided with an anode, a cathode and a signal grid, a source of space current, a series circuit comprising the space path of said space discharge device, said glow discharge device and said source of space current, a second space discharge device provided with an anode, a cathode and a signal grid, means for supplying the anode of said second space discharge device with anode potential comprising said source of space current, said source being connected to the anode of the second space discharge device through an inductive and resistive impedance circuit, a circuit including said glow discharge device directly connecting the anode and cathode of said second space discharge device and means for applying picture signals in phase opposition to the two grids of said two space discharge devices.

2. A circuit arrangement as described in the next preceding claim further characterized by that the glow discharge device is connected in shunt with a resistance element, and means are provided for utilizing the voltage drop across a part of said resistance for biasing the grid of the first named space discharge device.

3. In a thermionic tube driving circuit for glow discharge tubes and the like of the type wherein distortion of the signal energy is introduced due to the fact that the impedance characteristic of the glow discharge tube can not be matched accurately to the impedance characteristic of the thermionic tube, means for compensating for the distortion of the signal energy comprising a pair of thermionic tubes each thereof being provided with an input circuit and an output circuit, the output circuit of each tube including a source of space current, means for connecting the glow discharge device in the output circuit of one of said tubes so as to form a series circuit comprising the space path of the tube, the glow tube and the source of current, means for connecting the glow discharge device in the output circuit of the other of said tubes so that said glow discharge device is in parallel with the space path of said other tube as respects the source of space current, means for impressing signaling energy upon both of said input circuits, the signaling energy impressed upon one of said circuits being in phase opposition to the signaling energy impressed upon the other thereof.

HARRY MELVILLE DOWSETT.
ERNEST FREDERICK GOODENOUGH.