

W. Smith,
Water Closet

No. 106,089.

Patented Aug. 2. 1870.

Fig. 1.

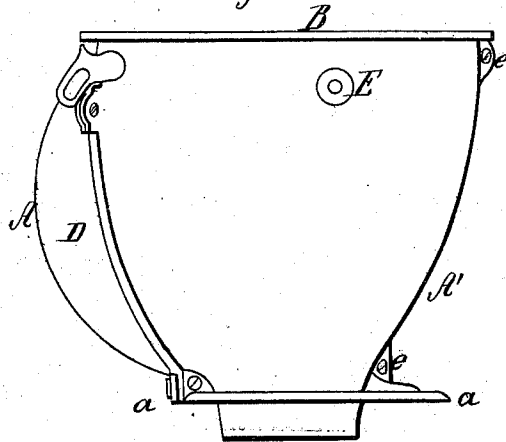

Fig. 2.

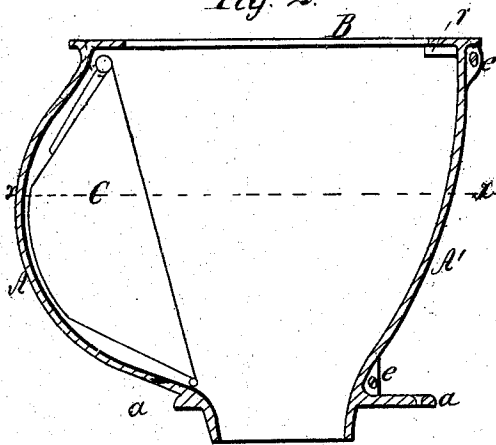
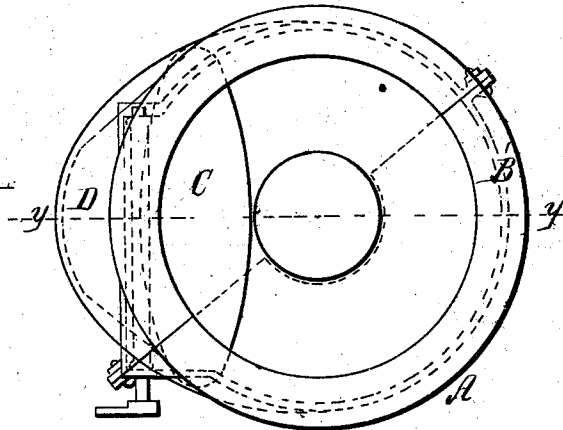

Fig. 3.



Witnesses;
C. W. Smith
H. P. Tibbey

Inventor;
W. Smith

UNITED STATES PATENT OFFICE.

WILLIAM SMITH, OF SAN FRANCISCO, CALIFORNIA.

IMPROVEMENT IN WATER-CLOSET RECEIVERS.

Specification forming part of Letters Patent No. 106,089, dated August 2, 1870.

To all whom it may concern:

Be it known that I, WILLIAM SMITH, of the city and county of San Francisco, State of California, have invented a certain new and useful Improvement in Water-Closet Receivers; and I do hereby declare that the following is a full and exact description of the same, reference being had to the accompanying drawing, and to the letters of reference marked thereon.

The nature of my said invention consists in constructing the receiver of water-closets so that I am able to make the side where the pan is hung correspond to the shape of the pan, and thereby save the waste space which is left behind the pan in ordinary or common receivers.

Heretofore the receivers or containers of pan-closets have been constructed of an oval bowl-shaped hopper, with a covering-plate, having an enlargement on one side, into which the pan swings when emptying. This construction forms a large space inside the receiver behind the pan which is not utilized, but, on the contrary, is detrimental to the closet in allowing obstructions to collect and impede the working of the pan.

In the drawing, Figure 1 represents a front view; Fig. 2, a vertical section through the line *y y* of Fig. 3; Fig. 3, a plan view through the line *x x* of Fig. 2.

Similar letters of reference indicate corresponding parts.

To enable others skilled in the art to which it most nearly appertains to make and use my invention, I will proceed to describe fully its construction and operation.

A A represent the two parts of the receiver bolted together, with the pan hanging in it as open. It will be noticed that there is no waste space behind the pan, but that the receiver conforms to its shape. B is the top flange on which the basin sits. C is the swinging pan, which shuts up to the under side of the flange

B'. D is the recess into which the pan swings. E is the socket for pivoting the end of the closet-lever.

In order to simplify the process of casting, I make the receiver in halves, with the basin-flange cast thereto, and bolt them together with four bolts, as seen at *e e e*, the line of division being across the center from the pan-shaft opening. The seams or edges where the halves are united are lapped and filled with cement in a substantial manner. There being no putty-joint under the top flange of the receiver, it is not liable to become leaky from the concussion of the pan in closing, as in ordinary receivers. The usual leather cushion is provided at *r* for the pan to strike against when closing.

a a represent the floor-flange, by which the receiver is secured in position on the soil-pipe. The fastening-bolts *e e e* pass through lugs cast on each half of the receiver for that purpose.

By this mode of construction I am able to make a much more perfect article in form, besides saving an important item in the weight of the casting, and consequently in transportation.

Having thus described my invention, what I claim, and desire to secure by Letters Patent, is—

A receiver for pan water-closets, formed and constructed so that the side A D, into which the pan C swings for emptying, will conform to the shape of the pan, and avoid the waste space behind the pan, as in ordinary or common receivers, substantially as and for the purpose set forth.

In testimony whereof I have hereunto set my hand and seal.

W. SMITH. [L. s.]

Witnesses:

C. W. M. SMITH,
H. S. TIBBEY.