

W. S. ROSS.

FEMALE URINAL.

APPLICATION FILED APR. 28, 1910.

977,903.

Patented Dec. 6, 1910.

2 SHEETS—SHEET 1.

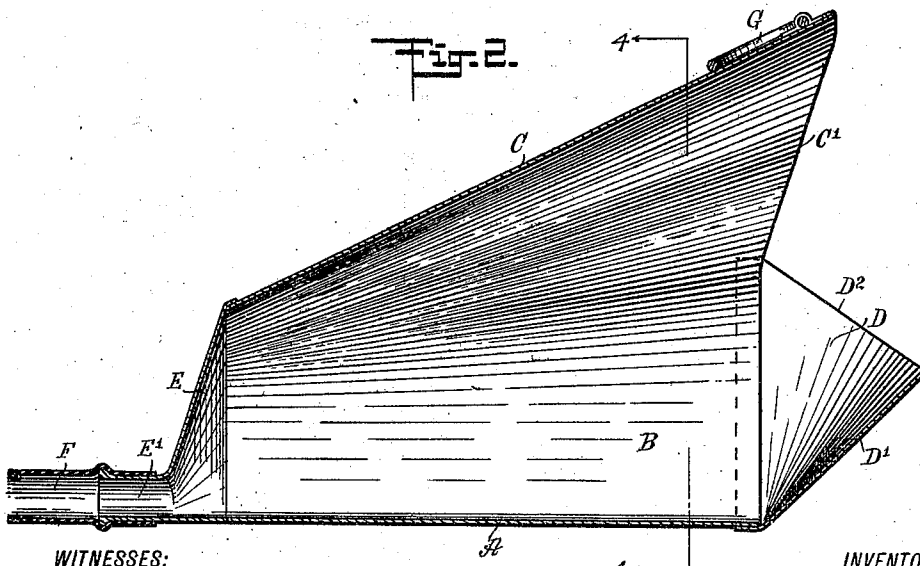
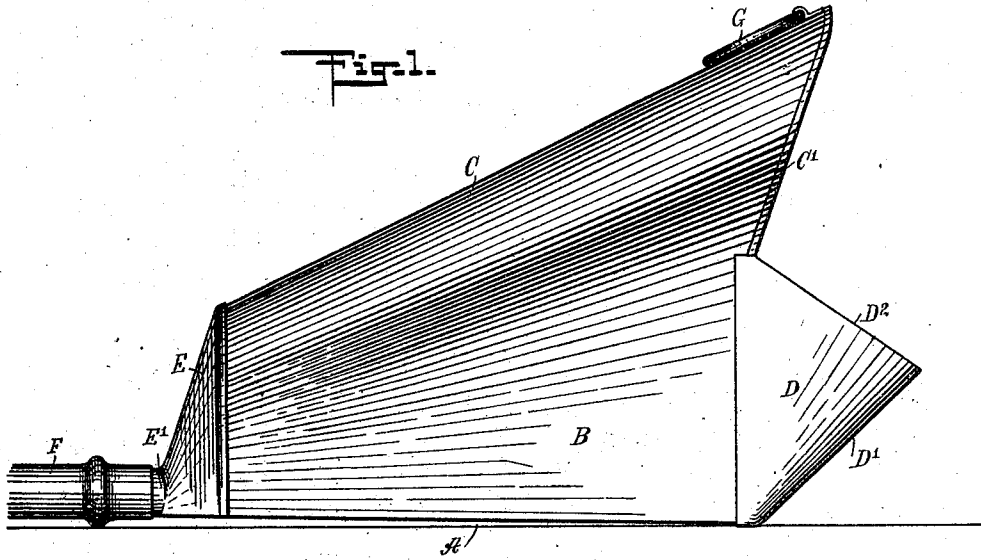

WITNESSES:

A. S. Hachenberg
Wm. G. Hoster

INVENTOR
William Scott Ross

BY *Munn Co.*

ATTORNEYS

W. S. ROSS.
 FEMALE URINAL.
 APPLICATION FILED APR. 28, 1910.

977,903.

Patented Dec. 6, 1910.

2 SHEETS—SHEET 2.

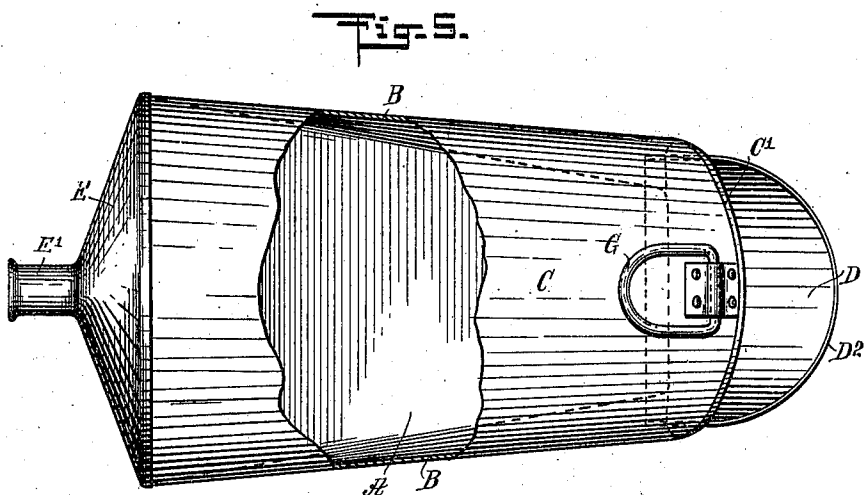
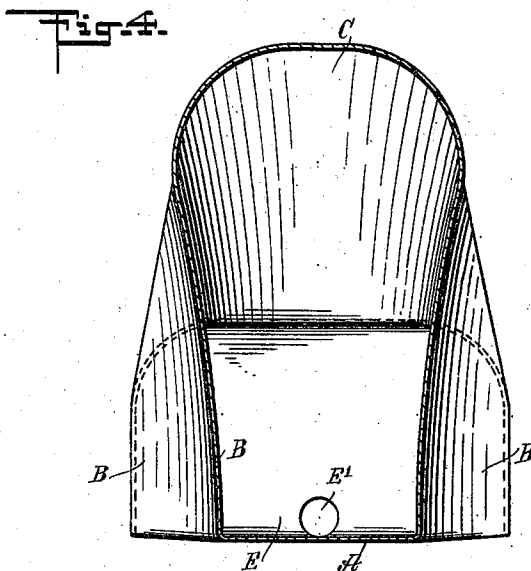
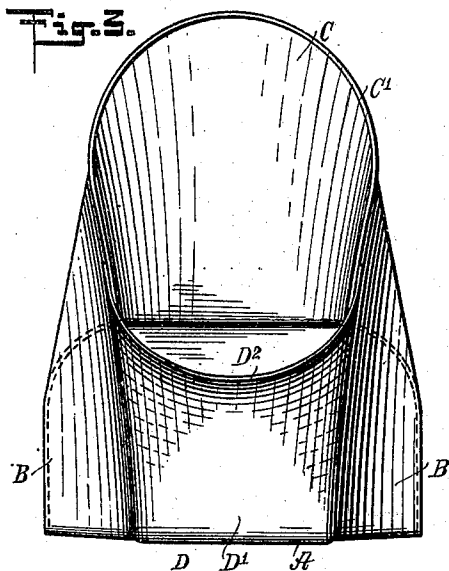

WITNESSES:

F. L. Hackmeyer
Rev. J. H. Foster

INVENTOR
William Scott Ross
 BY *Munn Co.*
 ATTORNEYS

UNITED STATES PATENT OFFICE.

WILLIAM SCOTT ROSS, OF NEW YORK, N. Y.

FEMALE URINAL.

977,903.

Specification of Letters Patent.

Patented Dec. 6, 1910.

Application filed April 28, 1910. Serial No. 558,282.

To all whom it may concern:

Be it known that I, WILLIAM SCOTT ROSS, a subject of the King of Great Britain, and a resident of the city of New York, borough of Brooklyn, in the county of Kings and State of New York, have invented a new and Improved Female Urinal, of which the following is a full, clear, and exact description.

The object of the invention is to provide a new and improved female urinal, more especially designed for use, with the utmost comfort, by sick or invalid females while lying in bed, and without requiring lifting or sitting up of the user, at the same time insuring the reception of all the discharged urine, without danger of spattering the same and soiling the bed clothes or the user.

For the purpose mentioned, use is made of a receptacle having a flat bottom, converging sides, an inclined top having its front edge inclined upward and forwardly, a rear end for closing the rear of the bowl or pan, and a front end united with the said bottom and the lower front portions of the sides, the said front end having its front inclined upwardly and forwardly and its top edge inclined rearwardly and upwardly.

A practical embodiment of the invention is represented in the accompanying drawings forming a part of this specification, in which similar characters of reference indicate corresponding parts in all the views.

Figure 1 is a side elevation of the female urinal; Fig. 2 is a longitudinal sectional elevation of the same; Fig. 3 is a front elevation of the same; Fig. 4 is a cross section of the same on the line 4-4 of Fig. 2; and Fig. 5 is a plan view of the same, parts being in section.

The urinal is in the form of a receptacle made of glass, hard rubber, sheet metal or other suitable material, and having a bottom A narrowed from the rear to the front, and from the side edges of the said bottom a rise the sides B, B, which thus converge from the rear to the front of the receptacle. The top C of the receptacle forms a continuation of the sides B, B, and is inclined upwardly and forwardly, the front edge C' being arched in a transverse direction and inclined upwardly and forwardly. The front end D of the receptacle is in the form of a lip and extends from the front edges of the bottom A and sides B, B, the front end having its front D' inclined upwardly and forwardly, and its top edge D² made approxi-

mately semicircular in a transverse direction and inclined downwardly and forwardly, to form with the front edge C' an entrance opening for the discharged urine. The rear end E of the receptacle is united with the rear of the bottom A, the sides B, B and top C, and the said rear end is preferably provided with an outlet spout E', for connection with a tube or hose F for conducting the urine to a chamber pot or other vessel located under the bed. The top C is provided near the front end with a ring or other hanger G, to permit of conveniently carrying the receptacle about or hanging it up on a nail or other support.

By constructing the vessel with the peculiarly shaped front D, sides B, B and top C, the urinal can be readily placed in position without discomfort to the user, at the same time preventing spattering of the discharged urine, thus preventing soiling of the bed clothes or the user.

The urinal shown and described is very simple and durable in construction and can be cheaply manufactured.

Being of certain shape and small, the urinal can be used without moving the patient. It is especially designed for patients afflicted with paralysis or injured leg or hip and operative abdominal trouble, where the present painful method now in general use in hospitals is to lift patients onto a bed pan. With hose attachment the patient can use the urinal with slight exertion.

Having thus described my invention, I claim as new and desire to secure by Letters Patent:

1. A female urinal, comprising a receptacle having a flat bottom narrowed from the rear to the front, sides extending upwardly from the side edges of the said bottom and converging from the rear to the front, a top integral with the said sides and inclined upwardly and forwardly, a rear end for closing the rear of the receptacle and connected with the said bottom, sides and top, and a front end forming a lip and connected with the front edge of the bottom and the lower front edge portions of the said sides, the said front end having its front extending upwardly and forwardly and the top edge of the front being approximately segmental and inclined upwardly and rearwardly.

2. A female urinal, comprising a receptacle having a flat bottom narrowed from

the rear to the front, sides extending upwardly from the side edges of the said bottom and converging from the rear to the front, a top integral with the said sides and inclined upwardly and forwardly, the front edge of the top being arched in a transverse direction and inclined upwardly and forwardly, a rear end for closing the rear of the receptacle and connected with the said bottom, sides and top, and a front end forming a lip and connected with the front edge portions of the said sides, the said front end having its front extending upwardly and forwardly and the top edge of the front being approximately segmental and inclined upwardly and rearwardly.

3. A female urinal, comprising a receptacle having a flat bottom narrowed from the rear to the front, sides extending upwardly from the side edges of the said bottom and converging from the rear to the

front, a top integral with the said sides and inclined upwardly and forwardly, a rear end for closing the rear of the receptacle and connected with the said bottom, sides and top, a front end forming a lip and connected with the front edge of the bottom and the lower front edge portions of the said sides, the said front end having its front extending upwardly and forwardly and the top edge of the front being approximately segmental and inclined upwardly and rearwardly, and an outlet spout at the said rear end for connection with a tube or hose.

In testimony whereof I have signed my name to this specification in the presence of two subscribing witnesses.

WILLIAM SCOTT ROSS.

Witnesses:

THEO. G. HOSTER,
PHILIP D. ROLLHAUS.