

(19) World Intellectual Property Organization
International Bureau



(43) International Publication Date
7 May 2009 (07.05.2009)

PCT

(10) International Publication Number
WO 2009/058902 A2

- (51) **International Patent Classification:**
G01N 33/561 (2006.01) **G01N 27/447** (2006.01)
G01N 33/543 (2006.01)
- (21) **International Application Number:**
PCT/US2008/081637
- (22) **International Filing Date:** 29 October 2008 (29.10.2008)
- (25) **Filing Language:** English
- (26) **Publication Language:** English
- (30) **Priority Data:**
11/981,404 30 October 2007 (30.10.2007) US
- (71) **Applicant (for all designated States except US):** **CELL BIOSCIENCES INC.** [US/US]; 1050 Page Mill Road, Palo Alto, CA 94303 (US).
- (72) **Inventors; and**
- (75) **Inventors/Applicants (for US only):** **YANG, Tom, Weisan** [US/US]; 1044 November Drive, Cupertino, CA 95014 (US). **BHAMIDIPATI, Arunashree** [US/US]; 3322 Waverley Street, Palo Alto, CA 94306 (US). **BORDUNOV, Andrei, V.** [US/US]; 406 J Union Avenue, Campbell, CA 95008 (US). **KNITTLE, James, Eugene** [US/US]; 1006 Woodgrove Lane, San Jose, CA 95136 (US). **O'NEILL, Roger, A.** [US/US]; 3180 Melendy Drive, San Carlos, CA 94070 (US). **VOSS, Karl, O.** [CA/US]; 930 Catamaran Street, Foster City, CA 94404 (US).
- (74) **Agents:** **SWIATEK, Maria, S.** et al.; Morgan Lewis & Bockius LLP, 2 Palo Alto Square, 3000 El Camino Real, Suite 700, Palo Alto, CA 94306 (US).
- (81) **Designated States (unless otherwise indicated, for every kind of national protection available):** AE, AG, AL, AM, AO, AT, AU, AZ, BA, BB, BG, BH, BR, BW, BY, BZ, CA, CH, CN, CO, CR, CU, CZ, DE, DK, DM, DO, DZ, EC, EE, EG, ES, FI, GB, GD, GE, GH, GM, GT, HN, HR, HU, ID, IL, IN, IS, JP, KE, KG, KM, KN, KP, KR, KZ, LA, LC, LK, LR, LS, LT, LU, LY, MA, MD, ME, MG, MK, MN, MW, MX, MY, MZ, NA, NG, NI, NO, NZ, OM, PG, PH, PL, PT, RO, RS, RU, SC, SD, SE, SG, SK, SL, SM, ST, SV, SY, TJ, TM, TN, TR, TT, TZ, UA, UG, US, UZ, VC, VN, ZA, ZM, ZW.
- (84) **Designated States (unless otherwise indicated, for every kind of regional protection available):** ARIPO (BW, GH, GM, KE, LS, MW, MZ, NA, SD, SL, SZ, TZ, UG, ZM, ZW), Eurasian (AM, AZ, BY, KG, KZ, MD, RU, TJ, TM), European (AT, BE, BG, CH, CY, CZ, DE, DK, EE, ES, FI, FR, GB, GR, HR, HU, IE, IS, IT, LT, LU, LV, MC, MT, NL, NO, PL, PT, RO, SE, SI, SK, TR), OAPI (BF, BJ, CF, CG, CI, CM, GA, GN, GQ, GW, ML, MR, NE, SN, TD, TG).
- Published:**
— without international search report and to be republished upon receipt of that report

(54) **Title:** METHODS AND DEVICES FOR ANALYTE DETECTION

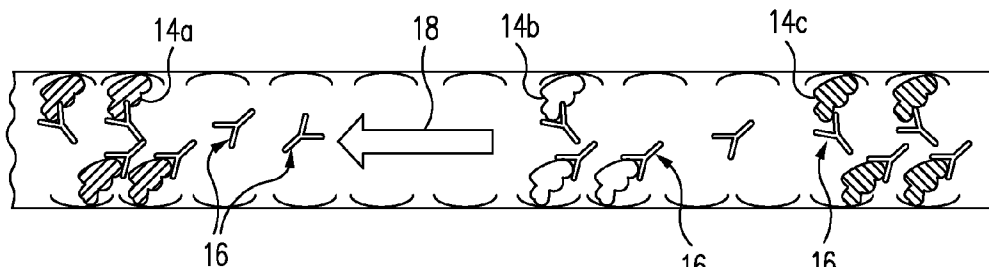

FIG. 1d

(57) **Abstract:** Methods for detecting one or more analytes, such as a protein, in a fluid path are provided. The methods include resolving, immobilizing and detecting one or more analytes in a fluid path, such as a capillary. Also included are devices and kits for performing such assays.

WO 2009/058902 A2

METHODS AND DEVICES FOR ANALYTE DETECTION

1. FIELD OF INVENTION

5 [0001] The present invention relates to methods, devices and kits for analyte detection and various uses thereof.

2. INTRODUCTION

[0002] Methods and devices for detecting analytes are important tools for characterizing analytes in biological and industrial applications. In many applications, it is desirable to
10 detect the presence of one or more analytes in a sample. For example, rapid detection of a particular protein in a mixture of proteins is particularly useful in molecular biology protocols, drug development and disease diagnosis.

[0003] Although numerous approaches have been developed for detecting analytes, there is still a great need to find new assay designs that can be used to inexpensively and
15 conveniently detect and characterize a wide variety of analytes. However, currently available assay protocols are inconvenient, expensive, or have other deficiencies. For example, Western blotting has been in widespread use for more than two decades for detecting proteins. In this technique, a sheet of gel is retained between two plates and usually is mounted vertically with the upper edge of the gel sheet accessible to the sample to be
20 assayed. The sample is applied in wells created along the upper edge of the gel and an electrophoretic potential is applied between the upper and lower edges of the sheet of gel. The electrophoretic potential is applied by a DC power supply, and may be in the range of 50 to more than 1000 volts. The electrophoretic potential is applied for a period of time that allows the proteins in the sample, to distribute themselves (i.e., separate) vertically through
25 the sheet of gel, typically for 1-4 hours, but in some cases considerably longer. The potential must be removed when the proteins are distributed as desired. The sheet of gel is then removed from between its two glass retaining plates and is then placed on a sheet of blotting material such as porous nitrocellulose of length and width dimensions approximately matching those of the sheet of gel, the blotting material having already been soaked in a
30 buffer to hydrate it. Care must be taken at this step to avoid the presence of air bubbles between the gel and the blotting material, which would impede the direct transfer of the distributed proteins from the gel to the blotting material. Two electrode plates are then

placed on either side of the gel and blotting material, thereby sandwiching the sheets of gel and blotting material between the electrode plates. The electrode plates should preferably apply a uniform electrophoretic field across the thicknesses of the sheets of gel and blotting material. This electrophoretic field, typically 100-500 volts, transfers the proteins from the gel to the blotting material in the same distribution in which they were captured in the gel matrix. This transfer process takes approximately 1-2 hours, but can take as much as overnight for some proteins to be transferred. After the proteins adhere to the blotting material, the blotting material is removed from the sandwich and is washed in a buffer containing one or more blocking agents such as skim milk, bovine serum albumin or tween-20 detergent for 1-4 hours and then is immersed in a solution of protein-specific reporter antibodies. During the immersion the blotting paper is typically agitated by a rocking or circular motion in the plane of the blotting paper. The immersion step typically takes 1-4 hours, but can take overnight or longer for some antibody-protein pairs. Reporter antibody detection can be done with a variety of markers such as optical dyes, radioactive or chromogenic markers, fluorescent dyes or reporter enzymes depending upon the analytical method used. These results are known as Western blots as described by Towbin H., Staehelin T., and Gordon J., Proc. Nat. Acad. Sci. USA, 76: 4350-4354 (1979), Burnette W.N., Anal. Biochem., 112: 195-203 (1981), and Rybicki & von Wechmar in J. Virol. Methods, vol. 5: 267-278 (1982).

[0004] The Western blot technique, while widely used, has a number of drawbacks and deficiencies. First, as the above description makes clear, the processing is very complex. There are many distinctly different steps, including the step of initially distributing the proteins being analyzed through the gel, the intermediate step of transferring the distributed proteins to the blotting material, the later step of binding the reporter antibodies, and the final step of reading or analyzing the results. Between these major steps are preparation steps and washing the variously processed components of the technique. Second, there is extensive handling of the components of the technique. The gel must be placed in the distribution apparatus, then removed and located in the blotting apparatus, then the blotting material must be handled to bind the reporter substrates. The components can be damaged during this handling, in particular the fragile sheet of gel. Third, it takes a considerable amount of time to arrive at just a single blot. At least a day is required to produce just one blot, and generally 1½-2 days are required. During the beginning of the process the accuracy of the technique is affected by migration of the proteins until they are immobilized in the blotting material,

which can result in band broadening. Fourth, the variability introduced by the complexity of the handling and processing can require the process to be repeated several times before acceptable results are obtained. Fifth, the variability in the results often requires subjective decisions to be made in reading the results of the blot. This subjectivity reduces the ability to obtain quantifiable, objective results and frequently limits the technique to practice by highly trained and experienced personnel. Sixth, the variability and complexity of the process impedes the ability to automate the process. Seventh, the technique has low sensitivity and generally is only effective with the contents of hundreds of thousands or millions of cells. Certainly, the technique cannot be used to analyze the enzymes of an individual mammalian cell. Eighth, the quantitation of the technique is poor. For one example, the agitation process may fail to cause the uniform binding of reporter substrates to the analytes in the blotting material. For another example, in the electroblotting step the time required to transfer some proteins is sufficient to enable other proteins to pass through the blotting membrane and be lost. Finally, the process can require large quantities of expensive probe and reporter antibodies to be used. In sum, the Western gel blotting technique is generally complex, time-consuming, expensive, insensitive and inexact.

[0005] Thus, although numerous approaches have been developed for detecting analytes, there is still a great need to find new methods and devices that can be used to conveniently and sensitively detect and characterize a wide variety of analytes.

20 3. SUMMARY

[0006] The present invention provides methods, devices, and kits for detecting one or more analytes of interest in a sample. In some embodiments, methods of detecting at least one analyte in a sample are provided, characterized in that: one or more analytes are resolved in a fluid path and the analyte(s) are immobilized in the fluid path. Detection agents are conveyed through the fluid path which bind to or interact with the analyte(s) and permit detection of the immobilized analyte(s) in the fluid path.

[0007] In another aspect, methods for detecting at least one protein in a sample are provided comprising the steps of: resolving one or more proteins in a capillary, photoimmobilizing one or more proteins in the capillary, contacting antibodies with the immobilized protein(s) to form antibody- protein complex(es) in the capillary, and detecting the protein(s).

[0008] In a further aspect, methods of detecting at least one protein in a sample are provided wherein one or more target proteins are resolved in a capillary. The capillary comprises at least one or more photoreactive groups. In some embodiments, the capillary comprises polymeric material or polymerizable material comprising one or more photoreactive groups.

5 The protein(s) are photoimmobilized in the capillary. Antibodies are then contacted with the photoimmobilized proteins and form antibody-protein complex(es) in the capillary, and the proteins are detected.

[0009] Further methods of detecting at least one protein in a sample are provided comprising the steps of: concentrating one or more proteins in a fluid path, immobilizing the protein(s) in
10 the fluid path; contacting the immobilized target protein(s) with detection agents to form a detection agent-protein complex(es) in the fluid path, and detecting the target protein.

[0010] Additionally, systems for detecting at least one analyte in a sample are provided, comprising a fluid path with one or more reactive groups contained therein, where the reactive groups are capable of immobilizing the analyte(s) in the fluid path. A power supply
15 is coupled to the fluid path and is configured to apply a voltage along the fluid path wherein the analytes are resolved in the fluid path. A detector is provided which detects the analytes immobilized in the fluid path.

[0011] In another aspect, kits for detecting at least one analyte in a sample are provided, comprising one or more fluid paths comprising one or more reactive moieties, buffer and
20 detection agents.

[0012] These and other features of the present teachings are set forth below.

4. BRIEF DESCRIPTION OF THE DRAWINGS

[0013] The skilled artisan will understand that the drawings, described below, are for illustration purposes only. The drawings are not intended to limit the scope of the present
25 teachings in any way.

[0014] FIGS. 1a-d illustrate exemplary embodiments of resolving, immobilizing and labeling cellular materials in a capillary.

[0015] FIGS. 2a-b illustrate exemplary embodiments of immobilizing resolved analytes in a polymeric material in a capillary.

[0016] FIGS. 3a-h illustrate exemplary embodiments of detecting one or more analytes.

[0017] FIG. 4 illustrates an exemplary embodiment of detecting cellular materials.

[0018] FIG. 5 illustrates an exemplary embodiment of analyzing cell(s).

[0019] FIG. 6 illustrates an exemplary embodiment of detecting cellular materials.

5 [0020] FIG. 7 illustrates an exemplary embodiment of analyzing cell(s).

[0021] FIG. 8 illustrates an exemplary embodiment of analyzing cell(s).

[0022] FIG. 9 illustrates an exemplary embodiment of analyzing cell(s).

[0023] FIG. 10 illustrates an exemplary embodiment of analyzing cellular materials.

10 [0024] FIG. 11 illustrates an exemplary embodiment of method for analyzing cellular materials.

[0025] FIGS. 12a-b illustrate exemplary embodiments of (a) a capillary between two fluid-filled wells and electrodes and (b) a capillary array device.

[0026] FIG. 13 illustrates an exemplary embodiment of an analytical system detection of cellular materials in a capillary by chemiluminescence.

15 [0027] FIG. 14 illustrates an exemplary embodiment of an analytical device.

[0028] FIG. 15 illustrates an exemplary embodiment of an analytical device.

[0029] FIG. 16 illustrates an exemplary embodiment of an analytical device.

[0030] FIG. 17 illustrates fluorescent detection of Green Fluorescent Protein.

[0031] FIG. 18 illustrates chemiluminescent detection of Green Fluorescent Protein.

20 [0032] FIG. 19 illustrates fluorescent detection of horse myoglobin.

[0033] FIG. 20 illustrates chemiluminescent detection of Akt protein.

[0034] FIG. 21 illustrates chemiluminescent detection of phosphorylated Akt protein.

[0035] FIG. 22 illustrates chemiluminescence detection of Akt protein and phosphorylated Akt protein.

[0036] FIG. 23 illustrates a TIF image of 12 capillaries containing analytes separated or resolved by size, immobilized, and detected by probing with HRP labeled antibodies and chemiluminescence, according to another embodiment of the present invention.

[0037] FIG. 24 shows a line graph of a signal emitted along the length of one capillary in Figure 23.

[0038] FIG. 25 is a line graph of the signal emitted from 2 proteins of similar size separated and detected within a capillary.

10 [0039] FIG. 26 illustrates a line graph of the signal emitted by a protein detecting GAPDH in a cell lysate that has been separated or resolved by size.

[0040] FIG. 27A depicts a line graph of fluorescent signal emitted by 5 proteins that have been separated by size within a capillary; and FIG. 27B shows a graph of the molecular weight of the proteins (Y axis) versus the pixel position of the proteins (X axis) as shown in
15 FIG. 27A.

[0041] FIG. 28 illustrates line graphs of three ERK proteins detected in a cell lysate that has been separated by size.

[0042] FIG. 29 shows two (2) images demonstrating immobilization of a target analyte induced by exposure to heat according to another embodiment of the present invention.

20 [0043] FIG. 30 illustrates data extracted from capillaries 2901 and 2907 of FIG. 29.

[0044] FIG. 31 illustrates data extracted from capillaries 2903 and 2909 of FIG. 29.

5. DETAILED DESCRIPTION OF EMBODIMENTS

[0045] It is to be understood that both the foregoing general description and the following description are exemplary and explanatory only and are not restrictive of the methods and devices described herein. In this application, the use of the singular includes the plural unless
25 specifically state otherwise. Also, the use of “or” means “and/or” unless state otherwise.

Similarly, “comprise,” “comprises,” “comprising,” “include,” “includes” and “including” are not intended to be limiting.

5.1 Definitions

5 [0046] As used throughout the instant application, the following terms shall have the following meanings:

10 [0047] “Antibody” has its standard meaning and is intended to refer to full-length as well as antibody fragments, as are known in the art, including Fab, Fab₂, single chain antibodies (Fv for example), monoclonal, polyclonal, chimeric antibodies, *etc.*, either produced by the modification of whole antibodies or those synthesized *de novo* using recombinant DNA technologies.

[0048] “Detect” and “detection” have their standard meaning, and are intended to encompass detection including the presence or absence, measurement, and/or characterization of an analyte.

15 [0049] “Label” as used herein refers to a detectable moiety. As will be appreciated by those in the art, suitable labels encompass a wide variety of possible moieties. In general, labels include, but are not limited to, a) isotopic labels, which may be radioactive or heavy isotopes; b) immune labels, which may be antibodies or antigens; c) optical dyes, including colored or fluorescent dyes; d) enzymes such as alkaline phosphatase and horseradish peroxidase, e) particles such as colloids, magnetic particles, *etc.*, and combinations thereof such as
20 fluorescent labeled antibodies, and chemiluminescent labeled antibodies.

[0050] “Protein” has its standard meaning and is intended to refer to proteins, oligopeptides and peptides, derivatives and analogs, including proteins containing non-naturally occurring amino acids and amino acid analogs, and peptidomimetic structures, and includes proteins made using recombinant techniques, *i.e.* through the expression of a recombinant nucleic
25 acid.

5.2 Methods

[0051] Provided herein are methods of detecting one or more analytes in a sample. In some embodiments, methods of detecting at least one analyte in a sample are provided, characterized in that: one or more analytes are resolved in a fluid path and the analyte(s) are

immobilized in the fluid path. Detection agents are conveyed through the fluid path, which bind to or interact with the analytes and permit detection of the immobilized analytes in the fluid path.

5 [0052] In some embodiments, methods of detecting at least one analyte of interest in a sample are provided. In some embodiments, the method comprises resolving one or more analytes in a fluid path, immobilizing the analytes in the fluid path, and contacting the immobilized analytes with detection agents, and detecting the analytes. In some
10 embodiments, the method comprises separating a sample into two or more components in a fluid path, immobilizing one or more analytes of interest in the fluid path, and contacting the immobilized analytes with detection agents, and detecting the analytes.

[0053] The sample contains the analyte or analytes to be detected. The sample can be heterogeneous, containing a variety of components, *i.e.* different proteins. Alternatively, the sample can be homogenous, containing one component. The sample can be naturally
15 occurring, a biological material, or man-made material. For example, the sample can be a single cell or a plurality of cells, a blood sample, a tissue sample, a skin sample, a urine sample, a water sample, or a soil sample. In some embodiments, the sample comprises the contents of a single cell, or the contents of a plurality of cells. The sample can be from a living organism, such as a eukaryote, prokaryote, mammal, human, yeast, or bacterium, or the sample can be from a virus. In some embodiments, sequential samples can be assayed from a
20 single animal, such as sequential cuttings from a rodent tail over time.

[0054] In some embodiments, the sample can be one or more stem cells. A stem cell is any cell that has the ability to divide for indefinite periods of time and to give rise to specialized cells. Suitable examples include embryonic stem cells, such as human embryonic stem cells (hES), and non-embryonic stems cells, such as mesenchymal, hematopoietic, or adult stem
25 cells (MSC).

[0055] As will be appreciated by those skilled in the art, virtually any processing may be performed on the sample prior to detecting the analyte. For example, the sample can be subjected to a lysing step, denaturation step, heating step, purification step, precipitation step, immunoprecipitation step, column chromatography step, centrifugation, *etc.* In some
30 embodiments, the separation of the sample and immobilization may be performed on native

substrates, the analyte of interest, *i.e.* a protein, or may also undergo denaturation to expose their internal hydrophobic groups for immobilizing in the fluid path.

[0056] The analyte to be detected can be any analyte selected by the user. The analyte can comprise any organic or inorganic molecule capable of being detected. Non-limiting
5 examples of analytes that can be detected include proteins, oligopeptides and peptides, derivatives and analogs, including proteins containing non-naturally occurring amino acids and amino acid analogs. Other example of analytes that can be detected include
10 carbohydrates, polysaccharides, glycoproteins, viruses, metabolites, cofactors, nucleotides, polynucleotides, transition state analogs, inhibitors, drugs, nutrients, electrolytes, hormones, growth factors and other biomolecules as well as non-biomolecules, as well as fragments and combinations of all the forgoing.

[0057] As will be appreciated by those in the art, virtually any method of loading the sample in the fluid path may be performed. For example, the sample can be loaded into one end of the fluid path. In some embodiments, the sample is loaded into one end of the fluid path by
15 hydrodynamic flow. For example, in embodiments wherein the fluid path is a capillary, the sample can be loaded into one end of the capillary by hydrodynamic flow, such that the capillary is used as a micropipette. FIG. 3b illustrates an exemplary embodiment of loading a sample in capillary by capillary action. In some embodiments, the sample can be loaded into the fluid path by electrophoresis, for example, when the fluid path is gel filled and therefore
20 more resistant to hydrodynamic flow.

[0058] The fluid path can comprise any structure that allows liquid or dissolved molecules to flow. Thus, the fluid path can comprise any structure known in the art, so long as it is compatible with the methods and devices described herein. In some embodiments, the fluid path is a bore or channel through which a liquid or dissolved molecule can flow. In some
25 embodiments, the fluid path is passage in a permeable material in which liquids or dissolved molecules can flow.

[0059] The fluid path comprises any material that allows the detection of the analyte within the fluid path. The fluid path comprises any convenient material, such as glass, plastic, silicon, fused silica, gel, or the like. In some embodiments, the method employs a plurality of
30 fluid paths. A plurality of fluid paths enables multiple samples to be analyzed simultaneously.

[0060] The fluid path can vary as to dimensions, width, depth and cross-section, as well as shape, being rounded, trapezoidal, rectangular, *etc.*, for example. The fluid path can be straight, rounded, serpentine, or the like. As described below, the length of the fluid path depends in part on factors such as sample size and the extent of sample separation required to resolve the analyte or analytes of interest.

[0061] In some embodiments, the fluid path comprises a tube with a bore, such as a capillary. In some embodiments, the method employs a plurality of capillaries. Suitable sizes include, but are not limited to, capillaries having internal diameters of about 10 to about 1000 μm , although more typically capillaries having internal diameters of about 25 to about 400 μm can be utilized. Smaller diameter capillaries use relatively low sample loads while the use of relatively large bore capillaries allows relatively high sample loads and can result in improved signal detection.

[0062] The capillaries can have varying lengths. Suitable lengths include, but are not limited to, capillaries of about 2 to 20 cm in length, although somewhat shorter and longer capillaries can be used. In some embodiments, the capillary is about 3, 4, 5, or 6 cms in length. Longer capillaries typically result in better separations and improved resolution of complex mixtures. Longer capillaries can be of particular use in resolving low abundance analytes.

[0063] Generally, the capillaries are composed of fused silica, although plastic capillaries and PYREX (*i.e.*, amorphous glass) can be utilized. As noted above, the capillaries do not need to have a round or tubular shape, other shapes, so long as it is compatible with the methods and devices described herein can also be utilized.

[0064] In some embodiments, the fluid path can be a channel. In some embodiments, the method employs a plurality of channels. In some embodiments, the fluid path can be a channel in a microfluidic device. Microfluidics employs channels in a substrate to perform a wide variety of operations. The microfluidic devices can comprise one or a plurality of channels contoured into a surface of a substrate. The microfluidic device can be obtained from a solid inert substrate, and in some embodiments in the form of a chip. The dimensions of the microfluidic device are not critical, but in some embodiments the dimensions are in the order of about 100 μm to about 5mm thick and approximately about 1 centimeters to about 20 centimeters on a side. Suitable sizes include, but are not limited to, channels having a depth of about 5 μm to about 200 μm , although more typically having a depth of about 20 μm to

about 100 μ m can be utilized. Smaller channels, such as micro or nanochannels can also be used, so long as it is compatible with the methods and devices described herein.

[0065] In some embodiments, the fluid path comprises a gel. In some embodiments, the gel is capable of separating the components of the sample based on molecular weight. A wide variety of such gels are known in the art, a non-limiting example includes a polyacrylamide gel.

[0066] The methods generally comprise resolving one or more analytes, contained in a sample, in the fluid path. Methods of separating a mixture into two or more components are well known to those of ordinary skill in the art, and may include, but are not limited to, various kinds of electrophoresis. As used herein, electrophoresis refers to the movement of suspended or dissolved molecules through a fluid or gel under the action of an electromotive force applied to electrodes in contact with a fluid.

[0067] In some embodiments, resolving one or more analytes comprises isoelectric focusing (IEF) of a sample. In an electric field, a molecule will migrate towards the pole (cathode or anode) that carries a charge opposite to the net charge carried by the molecule. This net charge depends in part on the pH of the medium in which the molecule is migrating. One common electrophoretic procedure is to establish solutions having different pH values at each end of an electric field, with a gradient range of pH in between. At a certain pH, the isoelectric point of a molecule is obtained and the molecule carries no net charge. As the molecule crosses the pH gradient, it reaches a spot where its net charge is zero (*i.e.*, its isoelectric point) and it is thereafter immobile in the electric field. Thus, this electrophoresis procedure separates molecules according to their different isoelectric points.

[0068] In some embodiments, for example when resolving is by isoelectric focusing, an ampholyte reagent can be loaded into the fluid path. An ampholyte reagent is a mixture of molecules having a range of different isoelectric points. Typical ampholyte reagents are PharmalyteTM and AmpholineTM available from Amersham Biosciences of Buckinghamshire, England. Ampholytes can be supplied at either end of the fluid path, or both, by pumping, capillary action, gravity flow, electroosmotic pumping, or electrophoresis, or by gravity siphon that can extend continuously through the fluid path.

[0069] In some embodiments, resolving one or more analytes comprises electrophoresis of a sample in a polymeric gel. Electrophoresis in a polymeric gel, such as a polyacrylamide gel

or an agarose gel separates molecules on the basis of the molecule's size. A polymeric gel provides a porous passageway through which the molecules can travel. Polymeric gels permit the separation of molecules by molecular size because larger molecules will travel more slowly through the gel than smaller molecules.

5 [0070] In some embodiments, resolving one or more analytes comprises micellar electrokinetic chromatography (MEKC) of a sample. In micellar electrokinetic chromatography, ionic surfactants are added to the sample to form micelles. Micelles have a structure in which the hydrophobic moieties of the surfactant are in the interior and the charged moieties are on the exterior. The separation of analyte molecules is based on the
10 interaction of these solutes with the micelles. The stronger the interaction, the longer the solutes migrate with the micelle. The selectivity of MEKC can be controlled by the choice of surfactant and also by the addition of modifiers to the sample. Micellar electrokinetic chromatography allows the separation of neutral molecules as well as charged molecules.

[0071] The methods comprise immobilizing one or more resolved analytes in the fluid path.
15 As used herein, immobilizing refers to substantially reducing or eliminating the motion of molecules in the fluid path. The immobilization can be *via* covalent bonds or non-covalent means such as by hydrophobic or ionic interaction. In some embodiments, the resolved analytes of the sample are immobilized in the fluid path by isoelectric focusing.

[0072] In some embodiments, the fluid path comprises one or more reactive moieties. A
20 reactive moiety can be used to covalently immobilize the resolved analyte or analytes in the fluid path. The reactive moiety can comprise any reactive group that is capable of forming a covalent linkage with a corresponding reactive group of individual molecules of the sample. Thus, the reactive moiety can comprise any reactive group known in the art, so long as it is compatible with the methods and devices described herein. In some embodiments, the
25 reactive moiety comprises a reactive group that is capable of forming a covalent linkage with a corresponding reactive group of an analyte of interest. In embodiments employing two or more reactive moieties, each reactive moiety can be the same, or some or all of the reactive moieties may differ.

[0073] The reactive moiety can be attached directly, or indirectly to the fluid path. In some
30 embodiments, the reactive moiety can be supplied in solution or suspension, and may form bridges between the wall of the fluid path and the molecules in the sample upon activation.

The reactive moiety can line the fluid path or, in another embodiment, may be present on a linear or cross-linked polymer in the fluid path. The polymer may or may not be linked to the wall of the fluid path before and/or after activation.

5 [0074] A wide variety of reactive moieties suitable for covalently linking two molecules together are well-known. The actual choice of reactive moieties will depend upon a variety of factors, and will be apparent to those of skill in the art. For example, the reactive moiety can bind to carbon-hydrogen (C-H) bonds of proteins. Since many separation media also contain components with C-H bonds, chemistries that react with sulfhydryl (S-H) groups may be advantageous in that S-H groups are found uniquely on proteins relative to most separation
10 media components. Chemistries that react with amine or carboxyl groups may also be advantageous due to the prevalence of such groups on proteins.

[0075] Suitable reactive moieties include, but are not limited to, photoreactive groups, chemical reactive groups, and thermoreactive groups.

15 [0076] Photoimmobilization in the fluid path can be accomplished by the activation of one or more photoreactive groups. A photoreactive group comprises one or more latent photoreactive groups that upon activation by an external energy source, forms a covalent bond with other molecules. See, *e.g.*, U.S. Pat. No. 5,002,582 and 6,254,634, the disclosures of which are incorporated herein by reference. The photoreactive groups generate active species such as free radicals and particularly nitrenes, carbenes, and excited states of ketones
20 upon absorption of electromagnetic energy. The photoreactive groups can be chosen that are responsive to various portions of the electromagnetic spectrum, such as those responsive to ultraviolet, infrared and visible portions of the spectrum. For example, upon exposure to a light source, the photoreactive group can be activated to form a covalent bond with an adjacent molecule.

25 [0077] Suitable photoreactive groups include, but are not limited to, aryl ketones, azides, diazos, diazirines, and quinones.

[0078] In some embodiments, the photoreactive group comprises aryl ketones, such as benzophenone, acetophenone, anthraquinone, anthrone, and anthrone-like heterocycles or their substituted derivatives. Benzophenone is a preferred photoreactive moiety, since it is
30 capable of photochemical excitation with the initial formation of an excited singlet state that undergoes intersystem crossing to the triplet state. The excited triplet state can insert into

carbon-hydrogen bonds by abstraction of a hydrogen atom to create a radical pair. The subsequent collapse of the radical pair leads to formation of a new carbon-carbon bond. If a reactive bond (*e.g.*, carbon-hydrogen) is not available for bonding, the ultraviolet light-induced excitation of the benzophenone group is reversible and the molecule returns to ground state energy level upon removal of the energy source.

[0079] In some embodiments, the photoreactive group comprises azides, such as arylazides such as phenyl azide, 4-fluoro-3-nitrophenyl azide, acyl azides such as benzoyl azide and *p*-methylbenzoyl azide, azido formates such as ethyl azidoformate, phenyl azidoformate, sulfonyl azides such as benzenesulfonyl azide, and phosphoryl azides such as diphenyl phosphoryl azide and diethyl phosphoryl azide.

[0080] In some embodiments, the photoreactive group comprises diazo compounds and includes diazoalkanes such as diazomethane and diphenyldiazomethane, diazoketones such as diazoacetophenone and 1-trifluoromethyl-1-diazo-2-pentanone, diazoacetates such as *t*-butyl diazoacetate and phenyl diazoacetate, and beta-keto-alpha-diazoacetates such as *t*-butyl alpha diazoacetoacetate.

[0081] In some embodiments, the photoreactive group comprises diazirines such as 3-trifluoromethyl-3-phenyldiazirine, and photoreactive group comprises ketenes such as diphenylketene.

[0073] In some embodiments, the photoreactive group comprises a N-((2-pyridyldithio)ethyl)-4-azidosalicylamide, 4-azido-2,3,5,6-tetrafluorobenzoic acid, 4-azido-2,3,5,6-tetrafluorobenzyl amine, benzophenone-4-maleimide, benzophenone-4-isothiocyanate, or 4-benzoylbenzoic acid.

[0082] As described above, in embodiments employing two or more reactive moieties, each reactive moiety can be the same, or some or all of the reactive moieties may differ. For example, the fluid path can comprise photoreactive groups and chemically reactive. In some embodiments, the fluid path can comprise different photoreactive groups, non limiting examples include, benzophenone and 4-azido-2,3,5,6-tetrafluorobenzoic acid (ATFB).

[0083] In addition to the use of photoactivatable chemistry described above, chemical or thermal activation may also be employed.

[0084] In some embodiments, the reactive moiety comprises a functional group that can be used to attach the reactive moiety to an analyte by forming a covalent linkage with a complementary group present on the analyte. Pairs of complementary groups capable of forming covalent linkages are well known in the art. In some embodiments, the analyte
5 comprises a nucleophilic group and the reactive group comprises an electrophilic group. In other embodiments, the reactive group comprises a nucleophilic group and the analyte comprises an electrophilic group. Complementary nucleophilic and electrophilic groups, or precursors thereof that can be suitably activated, useful for forming covalent linkages stable in assay conditions are well known and can be used. Examples of suitable complementary
10 nucleophilic and electrophilic groups, as well as the resultant linkages formed there from, are provided in U.S. patent 6,348,596.

[0085] In some embodiments, the methods comprise contacting one or more analytes with one or more detection agents. A detection agent is capable of binding to or interacting with the analyte to be detected. Contacting the detection agent with the analyte or analytes of interest
15 can be by any method known in the art, so long as it is compatible with the methods and devices described herein. Examples for conveying detection agents through the fluid path include, but are not limited to, hydrodynamic flow, electroendosmotic flow, or electrophoresis.

[0086] The detection agents can comprise any organic or inorganic molecule capable of binding to interact with the analyte to be detected. Non-limiting examples of detection agents
20 include proteins, peptides, antibodies, enzyme substrates, transition state analogs, cofactors, nucleotides, polynucleotides, aptamers, lectins, small molecules, ligands, inhibitors, drugs, and other biomolecules as well as non-biomolecules capable of binding the analyte to be detected.

[0087] In some embodiments, the detection agents comprise one or more label moiety(ies).
25 In embodiments employing two or more label moieties, each label moiety can be the same, or some, or all, of the label moieties may differ.

[0088] In some embodiments, the label moiety comprises a chemiluminescent label. The chemiluminescent label can comprise any entity that provides a light signal and that can be used in accordance with the methods and devices described herein. A wide variety of such
30 chemiluminescent labels are known in the art. See, e.g., U.S. Pat. No. 6,689,576, 6,395,503, 6,087,188, 6,287,767, 6,165,800, and 6,126,870 the disclosures of which are incorporated

herein by reference. Suitable labels include enzymes capable of reacting with a chemiluminescent substrate in such a way that photon emission by chemiluminescence is induced. Such enzymes induce chemiluminescence in other molecules through enzymatic activity. Such enzymes may include peroxidase, beta-galactosidase, phosphatase, or others
5 for which a chemiluminescent substrate is available. In some embodiments, the chemiluminescent label can be selected from any of a variety of classes of luminol label, an isoluminol label, *etc.* In some embodiments, the detection agents comprise chemiluminescent labeled antibodies.

[0089] In some embodiments, the detection agents comprise chemiluminescent substrates.
10 Depending on their charge, the chemiluminescent substrates can be supplied from either end of the fluid path, once the analyte is immobilized in the fluid path. Uncharged substrates can be supplied from either end of the fluid path by hydrodynamic flow or electroendosmotic flow, for example. Chemiluminescent substrates are well known in the art, such as Galacton substrate available from Applied Biosystems of Foster City, California or SuperSignal West
15 Femto Maximum Sensitivity substrate available from Pierce Biotechnology, Inc. of Rockford, Illinois or other suitable substrates.

[0090] Likewise, the label moiety can comprise a bioluminescent compound. Bioluminescence is a type of chemiluminescence found in biological systems in which a catalytic protein increases the efficiency of the chemiluminescent reaction. The presence of a
20 bioluminescent compound is determined by detecting the presence of luminescence. Suitable bioluminescent compounds include, but are not limited to luciferin, luciferase and aequorin.

[0091] In some embodiments, the label moiety comprises a fluorescent dye. The fluorescent dye can comprise any entity that provides a fluorescent signal and that can be used in accordance with the methods and devices described herein. Typically, the fluorescent dye
25 comprises a resonance-delocalized system or aromatic ring system that absorbs light at a first wavelength and emits fluorescent light at a second wavelength in response to the absorption event. A wide variety of such fluorescent dye molecules are known in the art. For example, fluorescent dyes can be selected from any of a variety of classes of fluorescent compounds, non-limiting examples include xanthenes, rhodamines, fluoresceins, cyanines,
30 phthalocyanines, squaraines, bodipy dyes, coumarins, oxazines, and carbopyronines. In some embodiments, for example, where detection agents contain fluorophores, such as fluorescent dyes, their fluorescence is detected by exciting them with an appropriate light source, and

monitoring their fluorescence by a detector sensitive to their characteristic fluorescence emission wavelength. In some embodiments, the detection agents comprise fluorescent dye labeled antibodies.

5 [0092] In embodiments, using two or more different detection agents, which bind to or interact with different analytes, different types of analytes can be detected simultaneously. In some embodiments, two or more different detection agents, which bind to or interact with the one analyte, can be detected simultaneously. In embodiments, using two or more different detection agents, one detection agent, for example a 1^o antibody, can bind to or interact with one or more analytes to form a detection agent-analyte complex, and second detection agent, 10 for example a 2^o antibody, can be used to bind to or interact with the detection agent-analyte complex.

[0093] In some embodiments, two different detection agents, for example antibodies for both phospho- and non-phospho- forms of analyte of interest can enable detection of both forms of the analyte of interest. In some embodiments, a single specific detection agent, for example 15 an antibody, can allow detection and analysis of both phosphorylated and non-phosphorylated forms of a analyte, as these can be resolved in the fluid path. In some embodiments, multiple detection agents can be used with multiple substrates to provide color-multiplexing. For example, the different chemiluminescent substrates used would be selected such that they emit photons of differing color. Selective detection of different 20 colors, as accomplished by using a diffraction grating, prism, series of colored filters, or other means allow determination of which color photons are being emitted at any position along the fluid path, and therefore determination of which detection agents are present at each emitting location. In some embodiments, different chemiluminescent reagents can be supplied sequentially, allowing different bound detection agents to be detected sequentially.

25 [0094] Analyte detection includes detecting of the presence or absence, measurement, and/or characterization of an analyte. Typically, an analyte is detected by detecting a signal from a label and includes, but is not limited, to detecting isotopic labels, immune labels, optical dyes, enzymes, particles and combinations thereof such as chemiluminescent labeled antibodies and fluorescent labeled antibodies.

30 [0095] Detecting the analyte can be by any method known in the art, so long as it is compatible with the methods and devices described herein. Analyte detection can be

performed by monitoring a signal using conventional methods and instruments, non-limiting examples include, a photodetector, an array of photodetectors, a charged coupled device (CCD) array, *etc.* For example, a signal can be a continuously monitored, in real time, to allow the user to rapidly determine whether an analyte is present in the sample, and
5 optionally, the amount or activity of the analyte. In some embodiments, the signal can be measured from at least two different time points. In some embodiments, the signal can be monitored continuously or at several selected time points. Alternatively, the signal can be measured in an end-point embodiment in which a signal is measured after a certain amount of time, and the signal is compared against a control signal (sample without analyte), threshold
10 signal, or standard curve.

[0096] A signal can be a monitored, in real time?, to allow the user to rapidly determine whether an analyte is present in the sample, and optionally, the amount or activity of the analyte. In some embodiments, the signal can be measured from at least two different time
15 points. In some embodiments, the signal can be monitored continuously or at several selected time points. Alternatively, the signal can be measured in an end-point embodiment in which a signal is measured after a certain amount of time, and the signal is compared against a control signal (sample without analyte), threshold signal, or standard curve.

[0097] Typically, detecting the analyte comprises imaging the fluid path. In some
20 embodiments, the entire length of the fluid path can be imaged. Alternatively, a distinct part or portion of the fluid path can be imaged. The amount of the signal generated is not critical and can vary over a broad range. The only requirement is that the signal be measurable by the detection system being used. In some embodiments, a signal can be at least 2-fold greater than the background. In some embodiments, a signal between 2 to 10-fold greater than the
25 background. In some embodiments, a signal can be 10-fold greater than the background.

[0098] The amount of the signal generated is not critical and can vary over a broad range. The only requirement is that the signal be measurable by the detection system being used. In
some embodiments, a signal can be at least 2-fold greater than the background. In some
30 embodiments, a signal between 2 to 10-fold greater than the background can be generated. In some embodiments, a signal can be 10-fold greater than the background.

[0099] FIG. 1a-d illustrate exemplary embodiments of resolving, immobilizing and labeling cellular materials in a capillary. FIG. 1a is a longitudinal cross-sectional illustration of a capillary **10** which is lined with a photoreactive group **12**. Located within a fluid inside the capillary is a mixture of cellular proteins **14** of differing electrophoretic mobility as indicated by the different shading. In FIG. 1b an electric field has been applied to the fluid to separate the proteins in accordance with their isoelectric points by isoelectric focusing (IEF) into groups **14a**, **14b**, and **14c**. In FIG. 1c light **15** at the appropriate wavelength is applied to activate the photoreactive group which, when activated as indicated at **12a**, binds the proteins **14** at their separated locations within the capillary. Detection antibodies **16** carrying a label are then flowed through the capillary as indicated by arrow **18** in FIG. 1d. The detection antibodies **16** will bind to the proteins **14** they encounter as shown in FIG. 1d. When the detection antibodies contain chemiluminescent label, the bound proteins are then labeled in their bound locations for luminescent detection. In this embodiment, a stream of chemiluminescence reagents can be flowed through the capillary, reacting when encountering the label linked to the proteins. The luminescence from the sites of the proteins is detected by a photon detector and recorded, enabling identification of the proteins by the light emitted from their bound locations. The technique advantageously permits the identification of cellular materials and, in the case where modification of cellular materials (substrates) is being monitored, allows the use of these native substrates without the need to introduce any identification substances prior to the separation of the cellular materials by IEF.

[0100] Generally, the methods described herein yield results similar to those obtained by a Western blot but in a fraction of the time. For example, the separation of cellular materials by IEF can take 5 minutes or less, and subsequent immobilization takes 2 minutes or less. This means that the detection agents can be linked to the separated sample within 10 minutes or less of the commencement of separation, and that the detection agents can be analyzed within 30 minutes of the separating step. The entire process is faster, simpler, more sensitive, more accurate and more automatable than the Western blot analytical technique. The immobilization step obviates the need to assess the detection agents (such as enzyme-labeled antibodies) for homogeneity of molecular form prior to use and obviates the need for excessive purification not typical of these types of reagents. Thus, less costly probing antibodies can be used in the methods described herein.

[0101] While the separation technique shown in the previous embodiment is isoelectric focusing, free solution electrophoresis, sieving electrophoresis, or micellar electrokinetic chromatography for example, may also be used to resolve the analytes.

5 [0102] In some embodiments, methods of detecting at least one analyte is provided, comprising, resolving one or more proteins in a fluid path, immobilizing the analytes in the fluid path; and contacting the immobilized analytes with detection agents to form one or more detection agent-analyte complexes in the fluid path, and detecting the analyte. In some
10 embodiments, the detection agent comprises a label. In some embodiments, the method further comprises contacting the detection agent-analyte complex with a labeled detection agent. In some embodiments, the method comprises detecting a chemiluminescent signal. In some embodiments, the method comprises detecting a fluorescent signal.

[0103] In some embodiments, methods of detecting at least one protein of interest in a sample are provided, comprising: resolving one or more proteins in a capillary,
15 photoimmobilizing the proteins in the capillary, and contacting the immobilized proteins with antibodies to form one or more antibody-protein complexes in the capillary and detecting the protein. In some embodiments, the antibodies comprise a label. In some embodiments, the method further comprising contacting the antibody- protein complex with a labeled antibody. In some embodiments, the method comprises detecting a chemiluminescent signal. In some
20 embodiments, the method comprises detecting a fluorescent signal.

[0104] In some embodiments, methods of detecting at least one analyte in a sample are provided, comprising: resolving one or more analytes in a fluid path, wherein the fluid path
25 comprises one or more reactive groups and, optionally, polymeric or polymerizable materials comprising one or more reactive groups, and immobilizing the analytes in the fluid path and contacting detection agents to the immobilized analytes and detecting the analytes.

25 [0105] FIG. 2a-b illustrate exemplary embodiments of immobilizing resolved analytes, in a polymeric material in a capillary. FIG. 2a illustrates a longitudinal cross section of a capillary **10**. The upper panel shows capillary **10** walls coated on their interior surface with a photoreactive group **12**, represented by closed ovals. A suitable, non-limiting example of such material is polyacrylamide containing photoreactive groups, such as benzophenone
30 moieties. Also present in FIG. 2a are polymeric materials **24** in solution, represented by four-armed structures terminated in circles, where the circles represent photoreactive groups **12**.

A suitable, non-limiting example of such material is branched polyethylene glycol bearing photoreactive groups **12** such as benzophenone, ATRFB *etc.* In addition, two bands of resolved proteins **14a**, **14b** are shown, represented by the cross-hatched structures. FIG. 2b shows the structures described above after photoactivation **15**. Activation of the photoreactive groups is depicted by the concave semicircular structures **12a** on both the walls and the polymeric materials filling the capillary. Many of these photoreactive groups **12a** are associated with each other, with lengths of polymer, and with the proteins in bands, effectively cross-linking each of these together. Thus, the resolved protein bands are bound in place via a loose network of covalent bonds and polymeric materials. In some embodiments, it is desirable that the network form open-pored structures permitting the movement of materials such as detection agents, such as antibodies, through the loose network.

[0106] FIGS. 3a-h illustrate exemplary embodiments for detecting one or more analytes in a fluid path. FIG. 3a illustrates a capillary **10** and a sample **1** comprising a mixture of components containing one or more analytes of interest. FIG. 3b illustrates loading the sample **1** into the capillary **10** by capillary action. FIG. 3c illustrates the sample **1** loaded capillary **10**, comprising one or more reactive moieties, extending between two fluid-filled wells or troughs **20a**, **20b**. The components of the sample **1** are separated such that the analyte **1a** or analytes **1a** and **1b** of interests are resolved by one or more electrodes in contact with a solution on one side of the capillary **10** and another one or more electrodes is in contact with a solution on the other side of the capillary **10** as illustrated in FIG. 3d. FIG. 3e illustrates the activation of one or more reactive moieties capable of immobilizing the analytes **1a** and **1b** of interests in the capillary **10**. Detection agents **2** are then flowed through the capillary **10** as indicated by the arrow in FIGS. 3f and 3g. Detection agents **2** are then detected **3**, enabling detection of the analyte of interest in their immobilized locations in the capillary by the signal emitted as illustrated in FIG. 3h.

[0107] FIG. 4 illustrates an exemplary embodiment of method for analyzing cellular materials. In step **61** the cellular materials to be analyzed are located at one end of a capillary. In step **61a** the cellular materials are loaded in to the capillary. In step **62** the cellular materials are separated within the capillary, for example by IEF. In step **63** the separated materials are immobilized in the capillary. In step **64** detection agents, for example reporter antibodies, are bound to the immobilized analytes, such as proteins in the capillary.

In step **65** a chemiluminescent reagents, or other detection agents, are flowed through the capillary to produce the event to be detected, such as chemiluminescence. The emitted light is then detected in step **66**.

[0108] FIG. 5 illustrates an exemplary embodiment of a method of analyzing cell(s). In step **60** one or more cells to be analyzed are positioned at the end of a capillary. In step **60a** one or more cells are drawn into the capillary and are lysed. In step **62** the cellular materials are separated within the capillary, for example by IEF. In step **63** the separated materials are immobilized in the capillary. In step **64** detection agents, for example reporter antibodies, are bound to the immobilized analytes, such as proteins in the capillary. In step **65** a chemiluminescent reagent, or other detection agents, are flowed through the capillary to produce the event to be detected, such as chemiluminescence. The emitted light is then detected in step **66**.

[0109] FIG. 6 illustrates an exemplary embodiment of a method for analyzing cellular materials. In step **61** the cellular materials to be analyzed are located at one end of a capillary. In step **61a** the cellular materials are loaded into the capillary. In step **62** the cellular materials are separated within the capillary, for example by IEF. In step **63** the separated materials are immobilized in the capillary. In step **64** detection agents, for example reporter antibodies, are bound to the immobilized analytes, such as proteins in the capillary. In step **65a** fluorophores on the detection agents, for example fluorescent labeled antibodies, are excited with light. The emitted light is then detected in step **66**.

[0110] FIG. 7 illustrates an exemplary embodiment of analyzing cells. In step **60** one or more cells to be analyzed are positioned at the end of a capillary. In step **60a** one or more cells are drawn into the capillary and are lysed. In step **62** the cellular materials are separated within the capillary, for example proteins are resolved by IEF. In step **63** the separated materials are immobilized in the capillary. In step **64** detection agents, for example reporter antibodies, are bound to the immobilized analytes, such as proteins in the capillary. In step **65a** fluorophores on the detection agents, for example fluorescent labeled antibodies, are excited with light. The emitted light is then detected in step **66**.

[0111] FIG. 8 illustrates an exemplary embodiment in which labeled cellular materials are released from the cell at the moment of their introduction into the capillary. The cellular materials are then separated and immobilized. In step **91** one or more cells containing

detection agents are located at one end of a capillary. The cell or cells are then lysed in step 92 to release their labeled proteins and transported in the capillary. In step 93 the cellular materials are separated, for example within the capillary by IEF. In step 94 the separated materials are immobilized in the capillary. In step 95 a chemiluminescent reagent is then
5 flowed through the capillary to produce photons by chemiluminescence. The emitted photons are then detected in step 96.

[0112] FIG. 9 illustrates an exemplary embodiment in which analytes are labeled prior to separation. In step 101 one or more cells are located at one end of a capillary. The cell or cells are then lysed in step 102 to release their contents. In step 103 detection agents are
10 bound to the released cellular contents, for example proteins. In step 104 the cellular materials are separated within the capillary by IEF. In step 105 the separated labeled materials are immobilized in place in the capillary. In step 106 a chemiluminescence substrate is then flowed through the capillary to produce photons by chemiluminescence. The emitted photons are then detected in step 107.

[0113] FIG. 10 illustrates an exemplary embodiment for chemiluminescent detection of analytes. In step 302 an ampholyte reagent for the pH gradient is loaded into the fluid path. In step 304 enzyme-labeled antibodies able to catalyze chemiluminescence and able to bind the analyte of interest are loaded into the fluid path. The cell contents are loaded into the fluid path in step 306, whereupon the enzyme-tagged antibodies will bind with the analyte or
20 analytes of interest. A focusing isoelectric field is applied in step 308 to resolve and then immobilize the enzyme-tagged antibodies and analytes in a pH gradient. A chemiluminescent substrate compatible with the enzyme-labeled antibodies is supplied in step 310 and chemiluminescent emissions are then detected from the interaction of the chemiluminescent substrate with the enzyme-labeled antibodies and bound to analyte in step
25 312. In some embodiments, the analyte is immobilized by IEF and the chemiluminescent reagent is flowed through the fluid path by carrying its own charge at all pH's of the gradient.

[0114] FIG. 11 illustrates an exemplary embodiment for chemiluminescent detection of analytes. In this embodiment, a cell is lysed into or at the inlet of a capillary in step 402. The
30 lysis releases cellular contents which react with detection agents, for example chemiluminescent labeled antibodies, in step 404. The labeled and bound cellular contents are resolved in the capillary by isoelectric focusing in step 406. In step 408 a

chemiluminescent reagent is supplied which will react with the enzyme of the antibodies bound to the cellular contents. In this embodiment, the analyte is immobilized by IEF and the chemiluminescent reagent is flown through the fluid path by carrying its own charge at all pH's of the gradient. In step 410 chemiluminescence is detected with a photon detector such as a photocell or CCD array detector.

[0115] Variations of order of the steps of the methods described herein will readily occur to those skilled in the art. For example, the sample can be separated and then the analyte(s) immobilized at their resolved locations in the fluid path, prior to contacting the analyte(s) with the detection agents. In some embodiments, detection agents are contacted with the analyte(s) to form a complex and then the complex is resolved in the fluid path. In some embodiments, the detection agents could be preloaded into the sample thereafter loaded into the system. As another example, the resolving step, such as isoelectric focusing can be applied after the chemiluminescent reagents are supplied.

[0116] Also provided herein are methods of detecting at least one protein in a sample, characterized in that: one or more proteins are resolved from the sample in a capillary and the proteins are photoimmobilized in the capillary and antibodies are conveyed through said capillary which bind to or interact with the proteins or an antibody-protein complex and permit the detecting of the proteins while immobilized in said capillary.

[0117] Also, provided herein are methods of detecting at least one protein in a sample, comprising concentrating one or more analytes in a fluid path, immobilizing one or more analytes in the fluid path; and contacting the immobilized analyte with detection agents, and detecting the analyte of interest.

[0118] As used herein, concentrating means to make less dilute. Methods of concentrating a sample are well known to those of ordinary skill in the art, and may include, but are not limited to, various kinds of electrophoresis and isoelectric focusing *etc.*

[0119] Also provided are methods of detecting at least one protein in a sample, comprising, concentrating one or more proteins in a fluid path, immobilizing the proteins in the fluid path, and contacting the immobilized protein with antibodies to form one or more antibody-protein complexes in the fluid path, and detecting the protein.

[0120] FIGS. 23-28 illustrate exemplary embodiments for electrophoretic separation of a protein followed by detection.

[0121] FIG. 23 illustrates an oligonucleotide? by size an image taken by a CCD camera of 12 capillaries described in Example 6. Two protein analytes of different molecular weight, one 4.4 kDa (2301) the other 70 kDa (2302) were separated by size within a capillary. The analytes were immobilized to the wall. Uncaptured material was washed away, and then the proteins were allowed to come in contact with a first antibody that binds to both proteins. The unbound antibody was washed away. A horseradish peroxidase (HPR)-conjugated antibody that binds to said first antibody was then introduced into the capillary and allowed to contact said first antibody. Unbound material was then washed away. Chemiluminescent reagents were then flowed into the capillary and allowed to react with the HRP inducing a chemiluminescent glow that could be detected by the camera. The glow is greatest where the second antibody bound to the first antibody which, in turn, had bound to the analyte.

[0122] The image shows the light produced by chemiluminescence. The exposure is such that a background signal is bright enough to show the entire length of all 12 capillaries. However the signal emitted by antibodies bound to the immobilized antibody is more than 10 times the background.

[0123] FIG 24 illustrates data extracted from a single capillary of Example 6 is shown in graph form with the signal emitted (the glow) on the Y axis and the capillary length in pixels on the X axis. The CCD camera produces a 1024 by 1024 16 bit TIF file. The signal produced along the length of a capillary was extracted and plotted as signal versus capillary length.

[0124] What can clearly be seen in the graph is the strong signal produced by the 2 proteins that were separated in the capillary. They can therefore be unambiguously identified from each other. These proteins are very different in size, they were the only components of the sample, and the signal is very strong so there is no doubt that the two proteins have been separated, captured, and detected.

[0125] FIG. 25 shows results very similar to FIG. 24 of Example 6. This time however the two analytes only differ in size by less than 3%. Again the simplicity of the sample and the strong signal leaves no doubt as to the identity of the analytes. Also, the peaks were not

produced in identical experiments that lacked primary antibody. The experiment from Example 7 demonstrates the impressive resolution that is obtainable with the invention.

[0126] FIG. 26 shows data extracted from the experiment described in Example 8. A cell lysate contains over one hundred thousand different chemical species. Sample separation can be challenging, as can capture and probing. Background signal could be expected from nonspecific binding by the detection reagents.

[0127] A fluorescent standard was added to the capillary so that separation could be tracked. The standard was slightly smaller in size than the analyte so a strong signal just behind the fluorescent standard would be the presumed target protein (data not shown). Also, ampholytes were used to block sites of non-specific protein/protein interaction.

[0128] As expected a strong signal (2601) was detected just behind the fluorescent protein (which was run nearly to the end of the capillary). This was the presumed analyte, GAPDH. This signal was not detecting in controls lacking primary antibody or in experiments where a different antibody was used.

[0129] FIG. 27A shows fluorescent scanning traces of dye-labeled proteins that had been separated by size. To better identify proteins of interest, the performance of a sizing ladder needed to be established. Several proteins of known molecular weight were labeled with the fluorescent dye TAMRA. These were then combined and separated by size. An image was then taken using the same CCD camera through filters designed to block the light that excited the fluorescent dye, TAMRA. Figure 27B shows a semilogarithmic graph of the molecular weight of the protein on the Y axis versus the distance the protein was mobilized from the origin in the X axis. The approximate molecular weight of an analyte can be determined by comparing the mobility of the analyte to that of the standards on graphs such as these. The proteins used in this experiment are: Bovine Serum Albumen (66 kDa; 2704, 2705), Ovalbumen (45 kDa; 2703, 2706), GAPDH (37 kDa; 2702, 2707) Trypsinogen (24 kDa; 2701, 2708), and Myoglobin (17 kDa; 2700, 2709)

[0130] FIG. 28 shows the data from three capillaries in which ERK protein(s) are detected in a cell lysate by means of the invention. A cell lysate was added to the capillary, the sample was separated by size, the sample was immobilized to the wall of the capillary, and detection reagents were flowed through the capillary. A fluorescent size ladder used in the experiment indicates that the analyte is the expected size of the ERK preteins (data not shown). The

peak(s) are not seen in capillaries where the primary antibody (specific to ERK1 and 2) is omitted. Lastly, there are 2 forms of ERK that this antibody binds to that differ in size slightly. Presumably the smaller ERK2 protein is the faster moving peak of the doublets (2801) and the larger ERK1 protein is peak 2802.

5 [0131] FIGS. 29-31 illustrates exemplary embodiments where analytes are resolved within the fluid path by performing an electrophoretic separation. The analytes are then immobilized within the fluid path using heat. Detection reagents are then flowed through the fluid path and allowed to come in contact with the analytes. The analytes are then detected

10 [0132] FIG. 29 contains 2 images demonstrating immobilization of a target analyte is induced by exposure to heat. The contrast of the images has been adjusted to allow visualization of background signal so that the location of the capillaries could be visualized. The capillaries in the two images are identical except that the capillaries in image 2900 were exposed to heat and the capillaries in image 2920 were not. All capillaries contain 38 $\mu\text{g/ml}$ of a cell lysate that expressed an ERK-GFP fusion protein. Capillaries from top to bottom contain increasing
15 amounts of recombinant GFP: 0 ng/ml (2901 and 2907), 20 ng/ml (2902 and 2908), 40 ng/ml (2903 and 2909), 80 ng/ml (2904 and 2910), 150 ng/ml (2905 and 2911), and 300 ng/ml (2906 and 2912).

20 [0133] FIG. 30 shows graphs of the data extracted from the TIF images used to produce Figure 29. Specifically, data from heated capillary 2901 is shown as solid line 3001 and data from unheated control capillary 2907 is shown as dashed line 3002. The analyte, ERK-GFP was clearly immobilized by heat as shown by the peak that is several hundred times the background signal and the signal seen in the unheated control.

25 [0134] FIG. 31 shows graphs of the data extracted from the TIF images used to produce Figure 29. Specifically the data from heated capillary 2903 is shown as solid line 3101 and data from unheated control capillary 2909 is shown as dashed line 3102. The data shows a peak signal 3103 not seen in samples in which GFP was not added (Figure 30), confirming that the anti-GFP antibody is performing as expected and that the other peak (3104) corresponds to ERK-GFP. The presence of both peaks is dependent on heat to immobilize the analytes within the fluid path for probing with the detection reagents, as seen by the absence
30 of peaks in data extracted from capillary 2909, dashed line 3102.

5.3 Devices

[0135] Provided herein are systems and devices for detecting one or more analytes in a sample. The device generally comprises a fluid path; a power supply for applying a voltage along the fluid path for separating individual components of a sample in the fluid path; and a detector capable of detecting analyte(s) in the fluid path.

5 [0136] Also provided is a system for detecting at least one analyte of interest in a sample, comprising a fluid path comprising one or more reactive groups capable of immobilizing one or more analytes, a power supply for applying a voltage along the fluid path capable of resolving one or more analytes in the fluid path; and a detector capable of detecting the analyte(s) in said fluid path.

10 [0137] Also provided is a system for detecting at least one analyte of interest in a sample, comprising a fluid path comprising one or more reactive groups capable of immobilizing one or more analytes, a power supply for applying a voltage along the fluid path capable of concentrating one or more analytes in the fluid path; and a detector capable of detecting the analyte(s) in said fluid path

15 [0138] FIG. 12a illustrates an exemplarily embodiment wherein the fluid path comprises a capillary between fluid filled wells and electrodes. A capillary **10** comprising one or more reactive moieties extends between two fluid-filled wells or troughs **20a, 20b**. A sample is placed in one of the troughs, preferably at the orifice of the capillary. For example, the sample can be cellular contents that have been loaded into the capillary. In some
20 embodiments, the one or more cells are drawn into the capillary and lysed in-situ. In some embodiments, one or more cells may be placed in a well, trough or capillary opening and lysed to release the cellular contents. The sample is then flowed through the capillary as by electrophoresis and separated within the capillary, for example by isoelectric focusing. An electrode **22a, 22b** is located in the solution at each end of the capillary to apply the electric
25 field necessary for electrophoresis and isoelectric focusing. The detection agents used to label the analyte of interest can be located in the other trough, preferably after separation and immobilization have taken place, and flowed through the capillary by electrophoresis, electroendosmotic flow, or hydrodynamic flow (typically achieved by siphoning or pumping). In some embodiments, the detection agents can be loaded into the capillary from a
30 vessel, such a test tube. The detection agents are then introduced into one of the troughs and flowed through the capillary to elicit the detection events.

[0139] FIG. 12b illustrates an exemplary embodiment comprising an array of capillaries **30** extending between a plurality of wells **32a**, on one side and another plurality of wells **32b** on the other side. In some embodiments an array of capillaries can be extended between a trough, on one side and another trough on the other side. In some embodiments, an array of capillaries can extend between a common buffer reservoir, on one side and another common buffer reservoir on the other side. One or more electrodes **34a** is in contact with the solution on one side of the capillaries and another one or more electrodes **34b** is in contact with the solution on the other side of the capillaries. A portion of the electrodes may be integral to the reservoir structure. The reservoirs and capillaries are located on or in a substrate **36** such as a slide.

[0140] FIG. 13 is an exemplary embodiment, the separation and detection of antibody-analyte complexes within a capillary **122** is illustrated in a longitudinal cross-sectional view of a section of the capillary. Located at positions along the capillary **122** are antibody-analyte complexes **160**. Each antibody-analyte complex **160** has a net charge **164** which determines the charge-neutral location **162b** to which the complex will migrate. Each complex is located at its charge-neutral location **162a**, **162b**, **162c** in the pH gradient created by isoelectric focusing of the ampholyte reagent. The applied voltage potential focuses the analytes into narrow bands at these isoelectric locations as illustrated in the drawing. Passing through the capillary are chemiluminescent substrates **170** which travel in electrophoretic flow direction **172**. When a chemiluminescent substrate **170** encounters a labeled antibody-analyte complex **160** such as a peroxidase enzyme attached to an electrofocused antibody-protein complex, the chemiluminescent substrate is converted to a product plus light. The substrate **170a** represents a chemiluminescent substrate which is being converted. The conversion causes light **180** to be emitted by the substrate **170a**. Substrate products **170b** which result from such conversions continue to flow in the direction of arrow **172**. This process continues as long as unconverted chemiluminescent substrates **170** continue to flow through the capillary and encounter new chemiluminescent enzymes with which to react.

[0141] FIG. 14 illustrates an exemplary analytical device. An array of capillaries **40** which are loaded with the necessary one or more reactive moieties to immobilize the analytes, buffer, and sample to be analyzed is located in a light-tight box **42**. A controllable power supply **46** is coupled to the electrodes on either end of the capillaries to apply the voltages needed to separate the sample and to flow the detection agents and/or chemiluminescent

reagents through the capillaries. A voltage is applied to flow the sample into the capillary and to separate the sample, for example by isoelectric focusing. Alternatively, the sample may be loaded into the capillary by hydrodynamic flow and thereafter separated, for example by isoelectric focusing. An energy source (not shown) capable of activating the reactive moieties is provided. For example, a light source such as an ultraviolet lamp provides illumination inside the box to immobilize the individual components of the sample in their separated locations. In some embodiments, the system comprises a light source for induction of fluorescent label. One or more detection agents, such as those described herein, are introduced into the wells at one end of the capillaries and flowed through the capillaries, binding to the analytes. In some embodiments, detection reagent is introduced into the wells and flowed through the capillaries. In some embodiments, detection agents may be introduced from separate smaller wells. Additional smaller wells can be used to conserve detection agents. Viewing the capillaries within the box **42** to receive the photons emitted from the immobilized analytes and detection molecules is a CCD camera **44**. The system is controlled by a computer **48** which switches the power supply **46** and the light, controls the application of detection molecules and reagents, and records and analyzes the photon signals received by the CCD camera **44**. Similarly, a light source for induction of fluorescence of molecular standards run in the separation may allow detection with the same CCD camera used to detect chemiluminescence-produced light. Internal standards serve to calibrate the separation with respect to isoelectric point, or for an alternative separation mode, molecular weight. Internal standards for IEF are well known in the art, for example see, Shimura, K., Kamiya, K., Matsumoto, H., and K. Kasai (2002) Fluorescence-Labeled Peptide pI Markers for Capillary Isoelectric Focusing, *Analytical Chemistry* v74: 1046-1053, and US Patent No. 5,866,683. Standards to be detected by fluorescence could be illuminated either before or after chemiluminescence, but generally not at the same time as chemiluminescence.

[0142] In some embodiments, the analyte and standards are detected by fluorescence. The analyte and standards can each be labeled with fluorescent dyes that are each detectable at discrete emission wavelengths, such that the analyte and standards are independently detectable.

[0143] FIG. 15 is an exemplary embodiment in which the photons emitted from the detection molecules are received by a CCD array located beneath the capillary array **40**. The CCD

array **52** is monitored by a CCD controller **54** which provides amplified received signals to the computer **48**.

[0144] FIG. 16 illustrates an exemplary embodiment of an analytical device for capillary detection of cellular material by chemiluminescence. The system **110** comprises a
5 microscope **112** having a video ocular readout **114** such as a CCD camera displayed on a CRT screen and/or recorded by a videotape recorder or digital recorder (not shown). In some embodiments, the system allows digital storage of the images and pattern processing in a computer system for automated cell processing and analysis. The CCD video camera system **114** is capable of recording a real time bright field image of a target cell. The device may
10 optionally comprise a cell lysis device **16**, such as a laser, sonic generator, electronic pulse generator, or electrodes positioned adjacent to target cell(s) on a cover slip **36**. In the illustrated embodiment, after cell lysis, cell contents are loaded into the end of the capillary by hydrodynamic flow or electrophoresis. In some embodiments, this end of the capillary has already been loaded with a short (few mm or less) slug of labeled antibodies at the time of
15 cell lysis. Thereafter, following a hybridization period, if necessary, separation for example by isoelectric focusing is initiated.

[0145] A fused silica capillary **122** is positioned with a micromanipulator (not shown) so that the inlet **126** of capillary **122** is located above the cover slip **136** or slide or microwell plate positioned on a microscope stage **130**. The buffer solution around the cell and above the
20 cover slip or similar container is coupled to a high voltage potential. Hybridization can be performed by loading the cell with detection agents prior to lysis or hybridization may be performed in the buffer solution subsequent to lysis. In the latter event, a high concentration of detection agents surrounds or is located adjacent to the cell. One method for achieving the desired high concentration of cell contents in contact with a high concentration of detection
25 agents is to draw the cell contents by hydrodynamic or electrophoretic means into a short length of the capillary adjacent to the capillary end. In this mode this short region of the capillary may be pre-loaded with detection agents from another source such as a tube or well (not shown), or may be drawn into the capillary end along with the cell contents. The distal end **132** or proximal end **126** of capillary **122** is disposed in a solution **134** of
30 chemiluminescent substrates. In some embodiments, resolving and immobilizing the analyte or analytes of interest can occur prior to adding the detection agents. The detection agents are then flowed through the fluid path after the separating the sample and immobilization.

[0146] Ampholyte reagent **142** is electrically coupled to a high voltage potential which, when applied to the capillary solution, causes the development of a pH gradient within the capillary **22** by ampholyte migration. A high voltage power supply, such as model CZE 1000R manufactured by Spellman of Plainview, N.Y., which is capable of providing a 20,000 volt potential can be used to maintain the pH gradient in column or capillary **122**.

[0147] Fused silica capillary **122** may typically exhibit a 100 micron inner diameter and 360 micron outer diameter. The lumen walls can be coated with a neutral coating such as that manufactured by Supelco of Phoenix, Ariz. The coating is used to minimize the electroosmotic flow and thus shorten the migration times for the antibody-target complexes.

The total length of the capillary in this embodiment can be as long as 90 to 100 cm, but preferably is considerably shorter, in the range of 10 to 30 cm, or 3 to 6 cm. The cell chamber **136** serves as an inlet reservoir for targeted cell molecules and optionally the ampholyte reagent and chemiluminescent reagent(s) and can be held at ground potential relative to the high voltage potential at the other end of the capillary. In some embodiments either end of the capillary may be at high voltage potential and the other ground, or either end may be positive and the other negative. The outlet reservoir **134** may be held at 15 to 20 kV relative to ground at the proximal end of the capillary, for example. The actual potential used is generally chosen by the desired voltage drop per cm of capillary. Distal outlet **132** of capillary **122** is placed about 5 centimeters below inlet **126** in the case of hydrodynamic loading. For the case of electrophoretic loading, which may be equally or more effective, no particular elevation of the distal end of the capillary is required. Inlet **126** of capillary **122** is used as a micropipette for introducing the cellular contents into capillary **122** after cell lysis. Alternatively, the cell may be drawn intact into the capillary and then lysed in the capillary.

[0148] After removing 5 mm of polyimide coating from capillary **122** above inlet **126**, inlet **126** is mounted perpendicular to cover slip **136** by a micromanipulator (not shown). The micromanipulator enables precise positioning of the capillary lumen with respect to the target cell to be loaded or lysed and loaded into capillary **122**.

[0149] Capillary **122** includes an optical observation window **138** through which chemiluminescent or fluorescence events are observed and detected by a CCD array **140** or similar detector. An extended observation window **138** is desirable as it enables the parallel detection of a greater number of events than can be observed through the limited length of a shorter window. Generally the length of the observation window will be chosen in

consideration of the length of the CCD array **140** being used. If a non-clear coated capillary is used the polyimide coating of capillary **122** is removed over at least the length of the capillary which opposes the CCD array **140**. The observation window **138** is maintained in a fixed position in relation to the CCD array **140** either by mechanical or adhesive means.

5 Preferably the observation window and CCD array are enclosed in darkness so that the only light detected by the CCD array is that emitted by the chemiluminescent or fluorescent events within the capillary. The signals from the detected chemiluminescent or fluorescent events are coupled to a personal computer **144** where they are recorded. In some embodiments the event data may be recorded along with the position in the CCD array at which the event
10 occurred. The data is plotted and total signal corresponding to each focused band calculated using Origin software available from Microcal of North Hampton, Mass., DAX software available from Van Mierlo, Inc. of Eindhoven, The Netherlands, LabVIEW software available from National Instruments Corp., Austin, Texas, or similar data analysis packages. Data may be presented as a histogram, electropherogram, or other graphical representation, or
15 as a spreadsheet or other numerical format.

[**0150**] In some embodiments, a cell or cells which have not been preloaded with detection agents, the inlet **126** of the capillary **122** is positioned directly above the target cell or cells to be lysed. The cell or cells can be in contact with a high concentration of detection agents, or preferably, a high concentration of detection agents has already been loaded into the capillary
20 end at the time of cell lysis. The lysis device **116** is aimed to create a lysing shock wave or other cell lysing disruption adjacent to the cell or cells. When the lysing pulse is applied the cellular contents are released and the force of the lysing event may aid in propelling the cellular contents into the lumen of the capillary by hydrodynamic flow, electrophoresis, or electroendosmotic flow. Hybridization of the analytes of interest and the detection agents
25 takes place rapidly, either outside the capillary prior to loading of the cell contents, or inside the capillary. The degree of hybridization will be linearly related to the concentrations of the detection agent and the sample. For example, tight-binding (high binding avidity) antibodies provide molecules which will retain their linking characteristics during capillary transport and isoelectric focusing. Examples of such antibodies are those typically used in ELISA
30 (Enzyme Linked Immuno-Sorbent Assays). Preferably the hybridization is done under non-denaturing conditions. By causing the antibodies and their analytes to be in a natural state, recognition between the antibodies and their -target complexes and the chemiluminescent reporters is enhanced. The isoelectric focusing field is applied, causing the antibody-target

complexes to migrate to pH points of the pH gradient in the capillary at which their net charge is neutral. The complexes will become stationary in the capillary at pH points where the charge of their molecular components (*e.g.*, phospho, carboxyl, amino, and other charged functional groups) nets out to zero. If forces from flow or diffusion should cause the
5 complexes to drift away from their respective isoelectric points, the gradient field will migrate them back into their charge-neutral positions. The antibody-target complexes are thus resolved along the observation window **138** by capillary isoelectric focusing. In some embodiments, resolving and immobilizing the analyte or analytes of interest can occur prior to adding the detection agents. The detection agents are then flowed through the fluid path
10 after the separating the sample and immobilization.

[**0151**] The electrophoretic potential is then used to cause the chemiluminescent substrate solution **134** to flow through the capillary. This may be initiated at the same time as the electric field which is first applied to establish the pH gradient, or after the gradient has already been established and the antibody-target complexes have been focused. The substrate
15 or substrate(s) are chosen such that they exhibit(s) a net charge at all pH conditions encountered within the capillary so that the substrates do not resolve within the capillary but continue to flow in a continuous stream. As the substrates encounter antibody-target complexes along the capillary they are cleaved by the reporter enzyme of the antibody of the complexes, causing release of photons. Thus, as the stream of chemiluminescent substrate
20 continuously flows through the capillary, the resolved antibody-target complexes will continue to emit photons. Alternatively, an excitation source may be used allowing fluorescence detection. In embodiments where chemiluminescence is used, emission is continuous for as long as the flow of chemiluminescent substrates is promoted, and the noise associated with stray excitation light in fluorescence-based systems is avoided.

[**0152**] The photon emission events are detected by the adjacent CCD array **140** and the detected events accumulated by the computer. Detection and accumulation can be continued for a selected period of time, enabling long detection periods to be used for sensitive detection of very small amounts of targeted cellular molecules. When only a single labeled antibody is used, the number of events accumulated will be a measure of the amount of
30 analytes in the cell or cells used to prepare the lysate. To measure the amounts of different cell proteins or molecules, different antibodies which create different antibody-target complexes at different isoelectric points can be employed. By recording the number of

photon events and the locations along the CCD array at which the events were detected (corresponding to the focused bands or isoelectric points along the gradient field of the capillary) the photon events emanating from the differently labeled analytes can be segmented. For increased throughput, multiple parallel capillaries or channels can be run
5 past one or more CCD arrays incorporated into a single instrument. In another embodiment, multiple antibodies labeled with different fluorescent dyes having spectrally resolvable signals can be used to enable multiplexed analysis of different proteins in a single capillary.

[0153] Fluorescent standards can be read separately if desired, using the same detector before or after the chemiluminescence signals have been collected, by exposing the fluors to
10 excitation light. For an all fluorescence system, the analyte and standards can be discerned by using differentially excitable and detectable dyes.

[0154] While the CCD array is preferred for its ability to detect in parallel the photon events occurring along the array, it is understood that more restricted detection techniques may be acceptable in a given embodiment. For instance, a single photon sensor may be swept or
15 moved along the observation window 138 to detect the chemiluminescent or fluorescent photon events. This approach, however, may miss an event at one point of the capillary when the sensor is aimed or located at a different point of the capillary. Furthermore the use of an extended detection device such as the CCD array eliminates several drawbacks of a focused window-based detector. If the isoelectric gradient were moved past a single window for
20 detection, as is common with commercially available capillary IEF separation systems designed for commonly available fixed window location capillary electrophoresis instruments, resolution can be deteriorated by laminar flow within the capillary, and chemiluminescent or fluorescent sensitivity would be reduced due to the limited time that a photon source is in the observation window.

25 **5.4 Kits**

[0155] Also provided are kits for performing the methods, and for use with the systems and devices of the present teachings. Materials used in the present invention include but are not limited to a fluid path, capillaries, buffer, detection agents, one or more reactive moieties, polymeric or polymerizable materials comprising one or more reactive moieties;
30 chemiluminescent substrates, blocking solutions, and washing solutions. In some embodiments, the kit can further comprise immobilization agents, ampholytes, and one or

more reactive moieties. In some embodiments, the kit can further comprise chemicals for the activation of the reactive moiety. These other components can be provided separately from each other, or mixed together in dry or liquid form.

5

6. EXAMPLES

[0156] Aspects of the present teachings may be further understood in light of the following examples, which should not be construed as limiting the scope of the present teachings in any way.

10 6.1 Example 1. Fluorescence Detection of Green Fluorescent Protein (GFP)

[0157] *Preparation of GFP sample for analysis:* In a microcentrifuge tube, 40 μ L of DI water, 1 μ L of GFP at 1 mg/ml (Part number 632373, Beckton-Dickinson, San Jose, CA, USA), 5 μ L of bioPLUS pI 4-7 (Bio-World, Dublin, Ohio), and 2 μ L of ATFB-PEG cross-linking agent (2mM) were combined. The ATFB-PEG cross-linking agent consists of 15,000
15 MW branched polyethylene glycol (product number P4AM-15, SunBio, Anyang City, South Korea) in which each branch terminus was derivatized with an ATFB (4-azido-2,3,5,6-tetrafluorobenzoic acid) functionality (product number A-2252, Invitrogen Corporation, Carlsbad, California).

[0158] *Preparation of capillary:* 100 μ I.D. x 375 μ O.D. Teflon-coated fused silica capillary
20 with interior vinyl coating (product number 0100CEL-01, Polymicro Technologies, Phoenix, Arizona) was surface grafted on its interior with polyacrylamide containing 1 mole percent benzophenone. 4cm sections of this capillary material were cleaved from longer lengths and used as described below.

[0159] *Sample loading into capillary:* The sample as prepared above was loaded into
25 sections of capillary prepared as described above by touching the tip of the empty capillary to the sample as illustrated in FIG. 3b. Capillary action was sufficient to completely fill the capillary in less than five seconds.

[0160] *Separation by isoelectric focusing (IEF):* Capillaries loaded as described above were placed in a capillary holder as illustrated in FIG. 12b. A 20 mM NaOH solution was placed

in the cathode end and a 10 mM H₃PO₄ solution was placed in the anode end of the holder, in contact with the electrodes and capillaries. A potential of 300 V was then applied for 900 seconds to facilitate isoelectric focusing, which is often achieved within the first few minutes of this period. GFP was resolved in a 4-7 pI gradient.

5 [0161] *Immobilization by ultraviolet light:* After the focusing period the capillaries were irradiated for 30 seconds with UV light using an 1800 Watt F300S lamp (Fusion Systems, Inc., Gaithersburg, Maryland) at 5 inches distance from the capillaries to cause photo-crosslinking.

10 [0162] *Washing, blocking and probing step:* After immobilization as described above, the capillaries were removed from the capillary holder and the anodic end of each capillary was placed in contact with a TBST solution consisting of 10 mM Tris-HCl, 150 mM NaCl, 0.05% Tween 20, pH 6.8. A ≥ 5 mmHg vacuum source was applied to the cathodic end of each capillary and TBST solution was pulled through each capillary for 5 minutes. Using the same ≥ 5 mmHg vacuum source and capillary orientation, a 5% powdered skim milk solution (w/v) in TBST was pulled through each capillary for 20 minutes. Fluorescent dye labeled primary antibody solution (1:1000 dilution of Alexa-555-labeled rabbit anti-GFP, Part number A-31851, Molecular Probes, Eugene, OR, USA in 5% milk in TBST) was then introduced to each capillary using the same vacuum source applied for 2 minutes, followed by 10 minutes incubation with vacuum off. This antibody application procedure was repeated a total of 5
15 20 times. Then, the same approach was used to flush the capillary with 5% milk solution in TBST for 20 minutes. Finally the capillaries were flushed for 5 minutes with TBST, and then 2 minutes TBS (10 mM Tris-HCl, 150 mM NaCl).

25 [0163] *Detection by fluorescence:* For fluorescence detection, capillaries were read using a Molecular Dynamics Avalanche™ scanner with excitation at 532 nm and emission detection at 575 nm. The relative fluorescence units along the length of the capillary as pixel number is shown in FIG. 17. The pixel number scale in Figures 17-22 varies because of different CCDs and positioning relative to the capillary.

6.2 Example 2: Chemiluminescence Detection of GFP

30 [0164] *Preparation of GFP sample for analysis:* In a microcentrifuge tube, 40 μ L of DI water, 1 μ L of GFP at 1 mg/ml (Part number 632373, BD Biosciences, San Jose, CA, USA), 5 μ L of bioPLUS pI 4-7 (Bio-World, Dublin, Ohio), and 2 μ L of ATFB-PEG cross-linking

agent (2mM) were combined. The ATFB-PEG cross-linking agent consists of 15,000 MW branched polyethylene glycol (product number P4AM-15, SunBio, Anyang City, South Korea) in which each branch terminus was derivatized with an ATFB (4-azido-2,3,5,6-tetrafluorobenzoic acid) functionality (product number A-2252, Invitrogen Corporation, Carlsbad, California).

[0165] *Preparation of capillary:* 100 μ I.D. x 375 μ O.D. Teflon-coated fused silica capillary with interior vinyl coating (product number 0100CEL-01, Polymicro Technologies, Phoenix, Arizona) was surface grafted on its interior with polyacrylamide containing 1 mole percent benzophenone. 4cm sections of this capillary material were cleaved from longer lengths and used as described below.

[0166] *Sample loading into capillary:* The sample as prepared above was loaded into sections of capillary prepared as described above by touching the tip of the empty capillary to the sample as illustrated in FIG. 3b. Capillary action was sufficient to completely fill the capillary in less than five seconds.

[0167] *Separation by isoelectric focusing (IEF):* Capillaries loaded as described above were placed in a capillary holder as illustrated in FIG. 12b. A 20 mM NaOH solution was placed in the cathode end and a 10 mM H₃PO₄ solution was placed in the anode end of the holder, in contact with the electrodes and capillaries. A potential of 300 V was then applied for 900 seconds to facilitate isoelectric focusing, which is often achieved within the first few minutes of this period. GFP was resolved in a 4-7 pI gradient.

[0168] *Immobilization by ultraviolet light:* After the focusing period the capillaries were irradiated for 30 seconds with UV light using an 1800 Watt F300S lamp (Fusion Systems, Inc., Gaithersburg, Maryland) at 5 inches distance from the capillaries to cause photo-crosslinking.

[0169] *Washing, blocking and probing step:* After immobilization as described above, the capillaries were removed from the capillary holder and the anodic end of each capillary was placed in contact with a TBST solution consisting of 10 mM Tris-HCl, 150 mM NaCl, 0.05% Tween 20, pH 6.8. A ≥ 5 mmHg vacuum source was applied to the cathodic end of each capillary and TBST solution was pulled through each capillary for 5 minutes. Using the same ≥ 5 mmHg vacuum source and capillary orientation, a 5% powdered skim milk solution (w/v)

in TBST was pulled through each capillary for 20 minutes. Primary antibody solution (1:1000 dilution of rabbit anti-GFP, Part number A-11122, Molecular Probes, Eugene, OR, USA, in 5% milk in TBST) was then introduced to each capillary using the same vacuum source applied for 2 minutes, followed by 10 minutes incubation with vacuum off. This antibody application procedure was repeated a total of 5 times. Then, the same approach was used to flush the capillary with 5% milk solution in TBST for 20 minutes. A secondary (2^o) antibody solution was then applied (1:10,000 anti-rabbit HRP in 5% milk in TBST, Cat# 81-6120, Zymed, South San Francisco, CA), again by flowing antibody solution for 2 minutes with vacuum on followed by 10 minutes of incubation with vacuum off, repeating a total of 5 times. The capillaries were then again flushed with a 5% milk solution in TBST for 20 minutes. Finally the capillaries were flushed for 5 minutes with TBST, and then 2 minutes TBS (10 mM Tris-HCl, 150 mM NaCl).

[0170] *Detection by chemiluminescence:* For chemiluminescence detection, a mixture of equal parts of SuperSignal West Femto Stable Peroxide buffer (Cat#1859023, Pierce, Rockford, Illinois) and Luminol/Enhancer solution (Cat#1859022, Pierce, Rockford, Illinois) was supplied to the capillaries and flushed through with 5mmHg vacuum. Chemiluminescence signal was collected for 60 seconds using a CCD camera in a prototype chemiluminescence detection module produced by Cell Biosciences, U.S. Patent Application 60/669,694 filed 04/09/2005. The relative luminescence signal along the length of a capillary as pixel number is shown in FIG. 18.

6.3 Example 3: Fluorescent Detection of Horse Myoglobin.

[0171] *Preparation of protein sample:* was prepared at 20 μ g/ml in ** buffer and stored at 4°C until use, or frozen at -70°C for long-term storage.

[0172] *Preparation of sample for analysis:* In a microcentrifuge tube, 40 μ L of DI water, 2 μ L of 4 mg/ml purified horse myoglobin (Part number M-9267, Sigma-Aldrich, St. Louis, MO, USA) myoglobin solution, 5 μ L of Pharmalyte ampholyte pI 3-10 (Sigma, St. Louis), and 2 μ L of ATFB-PEG cross-linking agent (2 mM) were combined. The ATFB-PEG cross-linking agent consists of 15,000 MW branched polyethylene glycol (product number P4AM-15, SunBio, Anyang City, South Korea) in which each branch terminus was derivatized with an ATFB (4-azido-2,3,5,6-tetrafluorobenzoic acid) functionality (product number A-2252, Invitrogen Corporation, Carlsbad, California).

[0173] *Preparation of capillary:* 100 μ I.D. x 375 μ O.D. Teflon-coated fused silica capillary with interior vinyl coating (product number 0100CEL-01, Polymicro Technologies, Phoenix, Arizona) was surface grafted on its interior with polyacrylamide containing 1 mole percent benzophenone. 4cm sections of this capillary material were cleaved from longer lengths and used as described below.

[0174] *Sample loading into capillary:* The sample as prepared above was loaded into sections of capillary prepared as described above by touching the tip of the empty capillary to the sample as illustrated in FIG. 3b. Capillary action was sufficient to completely fill the capillary in less than five seconds.

[0175] *Separation by isoelectric focusing (IEF):* Capillaries loaded as described above were placed in a capillary holder as illustrated in FIG. 12b. A 20 mM NaOH solution was placed in the cathode end and a 10 mM H₃PO₄ solution was placed in the anode end of the holder, in contact with the electrodes and capillaries. A potential of 300 V was then applied for 900 seconds to facilitate isoelectric focusing, which is often achieved within the first few minutes of this period. Horse myoglobin was resolved in a 3-10 pI gradient.

[0176] *Immobilization by ultraviolet light:* After the focusing period the capillaries were irradiated for 30 seconds with UV light using an 1800 Watt F300S lamp (Fusion Systems, Inc., Gaithersburg, Maryland) at 5 inches distance from the capillaries to cause photo-crosslinking.

[0177] *Washing, blocking and probing step:* After immobilization as described above, the capillaries were removed from the capillary holder and the anodic end of each capillary was placed in contact with a TBST solution consisting of 10 mM Tris-HCl, 150 mM NaCl, 0.05% Tween 20, pH 6.8. A ≥ 5 mmHg vacuum source was applied to the cathodic end of each capillary and TBST solution was pulled through each capillary for 5 minutes. Using the same ≥ 5 mmHg vacuum source and capillary orientation, a 5% powdered skim milk solution (w/v) in TBST was pulled through each capillary for 20 minutes. Fluorescent labeling of goat anti-horse myoglobin primary antibody (part number A150-103A, Bethyl Labs, Montgomery, TX) was performed by NHS ester coupling chemistry with Alexa-647 dye (part number A20006, Molecular Probes, Eugene, OR). The primary antibody solution (1:50 dilution of Alexa-647-labeled goat anti-horse myoglobin in 5% milk in TBST) was then introduced to each capillary using the same vacuum source applied for 2 minutes, followed by 10 minutes

incubation with vacuum off. This antibody application procedure was repeated a total of 5 times. Then, the same approach was used to flush the capillary with 5% milk solution in TBST for 20 minutes. Finally the capillaries were flushed for 5 minutes with TBST, and then 2 minutes TBS (10 mM Tris-HCl, 150 mM NaCl).

5 [0178] *Detection by fluorescence:* For fluorescence detection, capillaries were read using a Molecular Dynamics Avalanche™ scanner with excitation at 633 nm and emission detection at 675 nm. The relative fluorescence units along the length of a capillary as pixel number is shown in FIG. 19.

10 6.4 Example 4: Chemiluminescence Detection of Akt protein from LNCaP Cell Lysate Sample:

[0179] *Preparation of cell lysate:* Cell lysate was prepared for analysis by lysing 1×10^6 LNCaP cells (Human prostate cancer cell line) in one ml of 4°C HNTG lysis buffer (20 mM HEPES pH 7.5, 150 mM NaCl, 0.1% Triton-X 100, 10% Glycerol). The resulting lysate was clarified of insoluble cellular debris through centrifugation at 11,000g for 15 min. at 4°C.
15 The supernatant was decanted to a fresh tube and stored at 4°C until use, or frozen at -70°C for long-term storage.

[0180] *Preparation of lysate sample for analysis:* In a microcentrifuge tube, 40µL of DI water, 50µL of cell lysate, 5µL of bioPLUS pi 4-7 (Bio-World, Dublin, Ohio), and 2µL of ATFB-PEG cross-linking agent (2 mM) were combined. The ATFB-PEG cross-linking agent
20 consists of 15,000 MW branched polyethylene glycol (product number P4AM-15, SunBio, Anyang City, South Korea) in which each branch terminus was derivatized with an ATFB (4-azido-2,3,5,6-tetrafluorobenzoic acid) functionality (product number A-2252, Invitrogen Corporation, Carlsbad, California).

[0181] *Preparation of capillary:* 100µ I.D. x 375µ O.D. Teflon-coated fused silica capillary
25 with interior vinyl coating (product number 0100CEL-01, Polymicro Technologies, Phoenix, Arizona) was surface grafted on its interior with polyacrylamide containing 1 mole percent benzophenone. 4cm sections of this capillary material were cleaved from longer lengths and used as described below.

[0182] *Sample loading into capillary:* The sample as prepared above was loaded into sections
30 of capillary prepared as described above by touching the tip of the empty capillary to the

sample as illustrated in FIG. 3b. Capillary action was sufficient to completely fill the capillary in less than five seconds.

[0183] *Separation by isoelectric focusing (IEF)*: Capillaries loaded as described above were placed in a capillary holder as illustrated in FIG. 12b. A 20 mM NaOH solution was placed in the cathode end and a 10 mM H₃PO₄ solution was placed in the anode end of the holder, in contact with the electrodes and capillaries. A potential of 300 V was then applied for 900 seconds to facilitate isoelectric focusing, which is often achieved within the first few minutes of this period. Akt was resolved in a 4-7 pI gradient.

[0184] *Immobilization by ultraviolet light*: After the focusing period the capillaries were irradiated for 30 seconds with UV light using an 1800 Watt F300S lamp (Fusion Systems, Inc., Gaithersburg, Maryland) at 5 inches distance from the capillaries to cause photocrosslinking.

[0185] *Washing, blocking and probing step*: After immobilization as described above, the capillaries were removed from the capillary holder and the anodic end of each capillary was placed in contact with a TBST solution consisting of 10 mM Tris-HCl, 150 mM NaCl, 0.05% Tween 20, pH 6.8. A ≥ 5 mmHg vacuum source was applied to the cathodic end of each capillary and TBST solution was pulled through each capillary for 5 minutes. Using the same ≥ 5 mmHg vacuum source and capillary orientation, a 5% powdered skim milk solution (w/v) in TBST was pulled through each capillary for 20 minutes. Primary antibody solution (1:100 dilution of rabbit anti-AKT, sc8312, Santa Cruz Biotechnology, Santa Cruz, CA, in 5% milk in TBST) was then introduced to each capillary using the same vacuum source applied for 2 minutes, followed by 10 minutes incubation with vacuum off. This antibody application procedure was repeated a total of 5 times. Then, the same approach was used to flush the capillary with 5% milk solution in TBST for 20 minutes. A secondary (2^o) antibody solution was then applied (1:10,000 anti-rabbit HRP in 5% milk in TBST, Cat# 81-6120, Zymed, South San Francisco, CA), again by flowing antibody solution for 2 minutes with vacuum on followed by 10 minutes of incubation with vacuum off, repeating a total of 5 times. The capillaries were then again flushed with a 5% milk solution in TBST for 20 minutes. Finally the capillaries were flushed for 5 minutes with TBST, and then 2 minutes TBS (10 mM Tris-HCl, 150 mM NaCl).

[0186] *Detection by chemiluminescence:* For chemiluminescence detection, a mixture of equal parts of SuperSignal West Femto Stable Peroxide buffer (Cat#1859023, Pierce, Rockford, Illinois) and Luminol/Enhancer solution (Cat#1859022, Pierce, Rockford, Illinois) was supplied to the capillaries and flushed through with 5mmHg vacuum. Chemiluminescence signal was collected for 60 seconds using a CCD camera in a prototype chemiluminescence detection module produced by Cell BiosciencesU.S. Patent Application 60/669,694 filed 04/09/2005. The relative luminescence signal along the length of a capillary as pixel number is shown in FIG. 20 and the upper panel of FIG. 22.

6.5 Example 5: Chemiluminescence Detection of Akt protein from LNCaP Cell Lysate Using Anti-phospho-S473-antibody:

[0187] *Preparation of cell lysate:* Cell lysate was prepared for analysis by lysing 1×10^6 LNCaP cells (Human prostate cancer cell line) in one ml of 4°C HNTG lysis buffer (20 mM HEPES pH 7.5, 150 mM NaCl, 0.1% Triton-X 100, 10% Glycerol). The resulting lysate was clarified of insoluble cellular debris through centrifugation at 11,000 g for 15 min. at 4°C. The supernatant was decanted to a fresh tube and stored at 4°C until use, or frozen at -70°C for long-term storage.

[0188] *Preparation of lysate sample for analysis:* In a microcentrifuge tube, 40 μ L of DI water, 50 μ L of cell lysate, 5 μ L of Pharmalyte ampholyte pI 3-10 (Sigma, St. Louis), and 2 μ L of ATFB-PEG cross-linking agent (2 mM) were combined. The ATFB-PEG cross-linking agent consists of 15,000 MW branched polyethylene glycol (product number P4AM-15, SunBio, Anyang City, South Korea) in which each branch terminus was derivatized with an ATFB (4-azido-2,3,5,6-tetrafluorobenzoic acid) functionality (product number A-2252, Invitrogen Corporation, Carlsbad, California).

[0189] *Preparation of capillary:* 100 μ I.D. x 375 μ O.D. Teflon-coated fused silica capillary with interior vinyl coating (product number 0100CEL-01, Polymicro Technologies, Phoenix, Arizona) was surface grafted on its interior with polyacrylamide containing 1 mole percent benzophenone. 4cm sections of this capillary material were cleaved from longer lengths and used as described below.

[0190] *Sample loading into capillary:* The sample as prepared above was loaded into sections of capillary prepared as described above by touching the tip of the empty capillary to the

sample as illustrated in FIG. 3b. Capillary action was sufficient to completely fill the capillary in less than five seconds.

[0191] *Separation by isoelectric focusing (IEF)*: Capillaries loaded as described above were placed in a capillary holder as illustrated in FIG. 12b. A 20 mM NaOH solution was placed in the cathode end and a 10 mM H₃PO₄ solution was placed in the anode end of the holder, in contact with the electrodes and capillaries. A potential of 300 V was then applied for 900 seconds to facilitate isoelectric focusing, which is often achieved within the first few minutes of this period. Protein was resolved in a 4-7 pI gradient

[0192] *Immobilization by ultraviolet light*: After the focusing period the capillaries were irradiated for 30 seconds with UV light using an 1800 Watt F300S lamp (Fusion Systems, Inc., Gaithersburg, Maryland) at 5 inches distance from the capillaries to cause photocrosslinking.

[0193] *Washing, blocking and probing step*: After immobilization as described above, the capillaries were removed from the capillary holder and the anodic end of each capillary was placed in contact with a TBST solution consisting of 10 mM Tris-HCl, 150 mM NaCl, 0.05% Tween 20, pH 6.8. A ≥ 5 mmHg vacuum source was applied to the cathodic end of each capillary and TBST solution was pulled through each capillary for 5 minutes. Using the same ≥ 5 mmHg vacuum source and capillary orientation, a 5% powdered skim milk solution (w/v) in TBST was pulled through each capillary for 20 minutes. Primary antibody solution (1:100 dilution of rabbit anti-phospho-S473 AKT, Part number 4051, Cell Signaling Technologies, Beverly, MA, USA, in 5% milk in TBST) was then introduced to each capillary using the same vacuum source applied for 2 minutes, followed by 10 minutes incubation with vacuum off. This antibody application procedure was repeated a total of 5 times. Then, the same approach was used to flush the capillary with 5% milk solution in TBST for 20 minutes. A secondary (2^o) antibody solution was then applied (1:10,000 anti-rabbit HRP in 5% milk in TBST, Cat# 81-6120, Zymed, South San Francisco, CA), again by flowing antibody solution for 2 minutes with vacuum on followed by 10 minutes of incubation with vacuum off, repeating a total of 5 times. The capillaries were then again flushed with a 5% milk solution in TBST for 20 minutes. Finally the capillaries were flushed for 5 minutes with TBST, and then 2 minutes TBS (10 mM Tris-HCl, 150 mM NaCl).

[0194] *Detection by chemiluminescence:* For chemiluminescence detection, a mixture of equal parts of SuperSignal West Femto Stable Peroxide buffer (Cat#1859023, Pierce, Rockford, Illinois) and Luminol/Enhancer solution (Cat#1859022, Pierce, Rockford, Illinois) was supplied to the capillaries and flushed through with 5mmHg vacuum.

5 Chemiluminescence signal was collected for 60 seconds using a CCD camera in a prototype chemiluminescence detection module produced by Cell Biosciences, U.S. Patent Application 60/669,694 filed 04/09/2005. The relative luminescence signal along the length of a capillary as pixel number is shown in FIG. 21 and the lower panel of FIG. 22.

[0195] FIG. 22 compares the chemiluminescence signals generated in FIGS. 21 and 22 illustrating the resolving of phosphorylated and non-phosphorylated forms of the Akt protein by a single, total-protein-specific antibody in the upper panel FIG. 21. The lower panel FIG. 21, showing the signal generated using the phospho-specific antibody, indicates that the peaks resolved in box A are phosphorylated forms, while those resolved in box B are non-phosphorylated at serine 473.

15 **6.6 Example 6: Electrophoretic Separation of a Protein and an Oligonucleotide by Size:**

[0196] In this example analytes are resolved within the fluid path by performing an electrophoretic separation through a polymer that separates molecules by size in a manner similar to SDS-polyacrylamide gel electrophoresis. The analytes are then immobilizing
20 within the fluid path. Detection reagents are flowed through the fluid path and allowed to come in contact with the analytes. The analytes are then detected.

[0197] *Synthesis of TAMRA-labeled Erk Peptide:* The ERK immunogen peptide sequence was obtained from the manufacturer (Millipore Corp, Billerica, MA) of the cognate antibody. The peptide, sequence PFTFDME LDDL PKERL KELIFQETARFQPGAPEAP, was
25 synthesized on a 0.1 M scale using FastMOC chemistry on an Applied Biosystems 433 Peptide Synthesizer using standard protocols, leaving an Fmoc group on the terminal proline residue. This protected peptide on resin was then treated in two different ways.

[0198] One portion was transferred to glassware, and the terminal Fmoc was removed by standard treatment with piperidine. Cleavage and deprotection was followed by preparative
30 reverse-phase HPLC purification to yield 1.0 mg of peptide. Purity was determined to be greater than 90% by HPLC.

[0199] The protected peptide (still bound to resin) was transferred to glassware, and the terminal FMOC was then removed by standard treatment with piperidine, followed by treatment with 5-TAMRA-SE under basic conditions (DIEA). After standard deprotection and cleavage, the labeled peptide was purified by preparative reverse-phase HPLC to give 0.3 mg of a reddish solid, which was determined to be about 90% pure by HPLC, monitoring at 556 nm. In this example the exact amount of standard added to the sample is not as important as that the same amount be precisely added to all tubes.

[0200] *Sample preparation:* The sample was created by combining the TAMRA-labeled Erk peptide (4.5 kDa) with recombinant Erk2-GST (70 kDa; cat. no. 14-539, Upstate) in 1X SDS sample loading buffer (50mM Tris-HCl at pH 8.8 and 1% SDS) at a final concentration of 0.23 mg/ml and 40.8 ng/ml respectively. The sample was incubated at 95°C for 3 min.

[0201] *Resolving the analytes by size and immobilizing them to the surface of the fluid path:* Five (5) cm sections of Teflon coated 100 micron ID capillaries were prepared as described in U.S. patent serial No. 11/654,143 from commercially available capillaries (Polymicro Technologies, cat #TSU100375). It should be noted that capillaries prepared as specified in the parent application to this application are also suitable. Capillary action was used to (nearly) fill 12 capillaries with commercially available sieving matrix (Beckman PN 391-163). The remaining volume of the capillary (about 1 to 10 nl) was filled with the sample by capillary action to create 12 replicates. SDS-MW gel buffer (included with polymer solution) was used as separation buffer. Separation was done at a constant voltage of 250V for 2000 seconds. Electrophoresis progress was monitored by following the TAMRA-labeled polypeptides migration down the capillary. Separated proteins were immobilized by irradiation with UV light using an 1800 Watt F300S lamp (Fusion Systems, Inc., Gaithersburg, Maryland) at 5 inches distance for 60 seconds.

[0202] *Washing and Probing:* After UV immobilization, capillaries were repeatedly washed with TBST-CTAB solution containing TBST (10mM Tris-HCl at pH 7.5, 150mM NaCl, 0.05% Tween20, and 5% CTAB (Cetyltrimethyl ammonium bromide)). Immobilized proteins were then incubated for 1 hr with anti-Erk1/2 primary antibodies (cat. no. 06-182, Upstate) diluted to 1:300 in TBST (10mM Tris-HCl at pH 7.5, 150mM NaCl, 0.05% Tween20). This was followed by another TBST-CTAB wash to remove non-specifically bound antibodies. Immobilized proteins were then incubated with HRP conjugated goat anti-rabbit secondary antibodies (cat. no. 81-6120, Zymed) diluted to 1:500 in TBST for 10 mins. Capillaries were

washed with TBST-CTAB and chemiluminescence detection was done used West Femto Stable Peroxide buffer and Luminol/Enhancer solution (cat. no. 1859023, 1859022, Pierce).

[0203] An image of the capillaries was taken using a CCD camera (Princeton Instruments) for 30 sec as shown in FIG. 23. Images are stored in a 16 bit TIF file format. Data was
5 extracted from the image and analyzed using Imagequant (Molecular Dynamics) and DAX software (Van Mierlo Software Consultancy). Graphed data from a representative capillary is shown in FIG. 24. More specifically, two protein analytes of different molecular weight, one 4.4 kDa (2301) the other 70 kDa (2302) were separated by size within a capillary. The analytes were immobilized to the wall. Uncaptured material was washed away, and then the
10 proteins were allowed to come in contact with a first antibody that binds to both proteins. The unbound antibody was washed away. A horseradish peroxidase (HPR)-conjugated antibody that binds to said first antibody was then introduced into the capillary and allowed to contact said first antibody. Unbound material was then washed away. Chemiluminescent reagents were then flowed into the capillary and allowed to react with the HRP inducing a
15 chemiluminescent glow that could be detected by the camera. The glow is greatest where the second antibody bound to the first antibody which, in turn, had bound to the analyte.

[0204] The graph displays chemiluminescent signal intensity on the 'Y' axis and pixel position on the 'X' axis. The exposure is such that a background signal is bright enough to show the entire length of all 12 capillaries. However the signal emitted by antibodies bound
20 to the immobilized antibody is more than 10 time the background. As can clearly be seen the 4.5 kDa peptide fragment migrated through the capillary faster then the 70 kDa protein. Thus the proteins were separated by size, immobilized within the fluid path, and detected by reagents flowed through the capillary.

25 6.7 Example 7: An Example of High Resolution Size Separation:

[0205] Methodologies were the same as in Example 6 with the following exceptions:

[0206] Recombinant proteins ERK1-GST and ERK2-GST were purchased from Upstate (Cat# 14536 and 14539 respectively). The molecular weight of ERK1-GST is 68 kDa and ERK2-GST is 70 kDa; thus the proteins differ in size by less than 3%. TAMRA dye-labeled
30 myoglobin was produced in-house using NHS-ester methodologies well known to those

skilled in the art. The three proteins were mixed in 1xSDS buffer at a concentration of 2.5 µg/ml. The sample was heated to 95°C for 3 min.

[0207] Ten µl of sample was placed into a sample well, and then introduced into the capillary by electrokinetic injection using 100V for 300 sec. This commonly used method of
5 introducing sample into capillaries and has been published extensively, Wehr et al., Capillary Electrophoresis of Proteins. CRC Press (1999), and is used by a variety of commercially available instruments.

[0208] Capillaries were transferred to running buffer and electrophoresis proceeded at 250V until the dye-labeled myoglobin (~17 kDa) reached the end of the capillary, about 2500
10 seconds.

[0209] The proteins were immobilized by UV illumination for 180 sec. Washing was performed as described in the previous example. A blocking step was introduced just prior to the first probing step consisting of 30 min exposure to TBST containing 1% ampholytes (pH range 2 to 12; Bioworld, Cat.# 764-032) to lower non-specific binding by the primary
15 antibody. Probing and detection were performed as described previously.

[0210] FIG. 25 presents data of the separation of the two proteins that differ in size by less than 3%. This degree of resolution was remarkable considering that the capillary in which the separation was performed was only 5 cm long. Further the proteins had only migrated two cm through the capillary. Again the simplicity of the sample and the strong signal leaves
20 no doubt as to the identity of the analytes. Also, the peaks were not produced in identical experiments that lacked primary antibody. The experiment from Example 7 demonstrates the impressive resolution that is obtainable with the present invention.

6.8 Example 8: Detection of a Protein in a Cell Lysate:

[0211] Methodologies were the same as in Example 6 with the following differences.

[0212] The sample was prepared as follows: a 1.5 mg/ml preparation of Hela cells in HNTG (20 mM Hepes (pH 7.5), 2.5 mM NaCl, 0.1% Triton, 10% glycerol and 0.1% protease inhibitor cocktail (cat. no. 539134; Calbiochem)) was diluted to 0.5 mg/ml with sample buffer (50 mM Tris pH 8.8 and 1% SDS). Dye labeled myoglobin was added to a concentration of 2 µg/ml.

[0213] The sample was introduced into the capillary by electrokinetic injection. Dye-labeled myoglobin was used as a means of following electrophoretic progress, as in the previous example. An ampholyte blocking step was used before probing with primary antibody.

[0214] The primary antibody used was mouse anti GAPDH (Novus Inc., cat# NB-300-221F).

5 An HRP-conjugated anti-mouse antibody (Zymed, Cat #816520) was used as the secondary antibody.

[0215] FIG. 26 shows data extracted from the experiment described in this Example 8. A cell lysate contains over one hundred thousand different chemical species. Sample separation can be challenging, as can capture and probing. The background signal could be expected from nonspecific binding by the detection reagents. A fluorescent standard was added to the
10 capillary so that separation could be tracked (data not shown). The standard was slightly smaller in size than the analyte so a strong signal just behind the fluorescent standard would be the presumed target protein. Also, ampholytes were used to block sites of non-specific protein/protein interaction. As expected a strong signal (2601) was detected just behind the
15 fluorescent protein (which was run nearly to the end of the capillary). This was the presumed analyte, GAPDH. This signal was not detecting in no primary antibody controls or in experiments where a different antibody was used. Data in FIG. 26 shows a peak (2601) around the 300 pixel point with a signal greater than 5 times the noise. This peak is presumed to correspond to the detection of GAPDH in the Hela lysate. A control capillary
20 that lacked the GAPDH primary antibody did not give rise to this peak (data not shown).

6.9 Example 9: Detection of ERK in a Cell Lysate:

[0216] In this example we detect native ERK1 and ERK2 in a K562 cell lysate. The protocol was the same as in Example 8 with the following modifications:

[0217] *Introduction of a size ladder:* Proteins of known size are commonly run in SDS-

25 PAGE gels in parallel to samples to assist in identifying analytes. A TAMRA dye-labeled size ladder of proteins was assembled composed of TAMRA-labeled alpha-lactalbumin, myoglobin, ovalbumin, GLDH and BSA. TAMRA labeled proteins were either obtained from commercial sources or made in-house using NHS-ester chemistry well known to those practiced in the art. We established that we were able to separate these proteins within our
30 capillaries. FIGs. 27A and 27B show fluorescent scanning data from a slightly different sizing ladder separated in the same capillaries described in these examples. In this example a

sizing ladder composed of the proteins listed above was used to identify the size of the analyte of interest.

[0218] A lysate of K562 cells (10.8 mg/ml) in RIPA buffer (25 mM Tris-HCl pH 7.6, 150 mM NaCl, 1% NP-40, 1% Sodium deoxycholate and 0.1 % SDS) was diluted into SDS buffer to a final concentration of 4.5 mg/ml. A size ladder composed as described above was added to give a final concentration of approximately 2 μ g/ml of each protein. The sample was introduced into the capillary by introducing a small (~10 nl) plug into the end as in Example 6. Electrophoretic separation was performed using 100V. The fluorescent standards were used to follow the progress of electrophoresis. UV immobilization was performed for 180 sec. The wash, block, and probe protocol was 300s with TBST-CTAB, block for 30 min with TBST with 1% Ampholytes, probe with a 1:300 dilution of ERK1/2 primary antibody (Millipore, CS 4695) in TBST for 1hr, Wash for 60s in TBST-CTAB, probe with a 1:100 dilution of secondary antibody (Pierce anti-rabbit, cat# 1858415) in TBST for 1 hr, wash for 60 sec in TBST-CTAB. Detection was as described previously.

[0219] Turning again to FIG. 27A fluorescent scanning traces of dye-labeled proteins that had been separated by size are shown. To better identify proteins of interest, the performance of a sizing ladder needed to be established. Several proteins of known molecular weight were labeled with the fluorescent dye TAMRA. These were then combined and separated by size. An image was then taken using the same CCD camera through filters designed to block the light that excited the fluorescent dye, TAMRA. Figure 27B shows a semilogarithmic graph of the molecular weight of the protein on the Y axis versus the distance the protein was mobilized from the origin in the X axis. The approximate molecular weight of an analyte can be determined by comparing the mobility of the analyte to that of the standards on graphs such as these. The proteins used in this experiment are: Bovine Serum Albumen (66 kDa; 2704, 2705), Ovalbumen (45 kDa; 2703, 2706), GAPDH (37 kDa; 2702, 2707) Trypsinogen (24 kDa; 2701, 2708), and Myoglobin (17 kDa; 2700, 2709).

[0220] FIG. 28 shows the data from three capillaries in which ERK protein(s) are detected in a cell lysate by means of the invention. A cell lysate was added to the capillary, the sample was separated by size, the sample was immobilized to the wall of the capillary, and detection reagents were flowed through the capillary. A fluorescent size ladder was used in the experiment indicates that the analyte is the expected size of the ERK preteins. The peak(s) were not seen in capillaries where the primary antibody (specific to ERK1 and 2) was omitted

(data not shown). Lastly, there are 2 forms of ERK that this antibody binds to that differ in size slightly. Presumably the smaller ERK2 protein is the faster moving peak of the doublets (2801) and the larger ERK1 protein is peak 2802. FIG. 28 clearly shows a strong peak with a signal greater than 10 times the background noise. Comparison to the fluorescent trace (data not shown) reveals the peak is of the expected molecular weight of the ERK proteins. Further all three of the traces appear to be doublets (2801 and 2802), suggesting that we have successfully resolved ERK1 (43.1 kDa) from ERK2 (41.3 kDa); a difference in molecular weight of less than 5%.

6.10 Example 10: Immobilization in a Fluid Path can be Activated by Heat:

10 [0221] In this example analytes are resolved within the fluid path by performing an electrophoretic separation. The analytes are then immobilized within the fluid path using heat according to another embodiment of the present invention. Detection reagents are then flowed through the fluid path and allowed to come in contact with the analytes. The analytes are then detected.

15 [0222] *Sample preparation:* The sample was prepared by combining the following reagents to their indicated final concentrations: 10 mM HEPES, 12.5 mM NaCl, 20% D-sorbitol, 225 mM NDSB 256, 5% glycerol, phosphatase inhibitors (1:200 dilution; Cal Biochem, cat#524627), protease inhibitors (1:2000 dilution; Sigma, cat#P2850), 5% ampholytes (3-10 gradient; Sigma, cat# P1522), 38 ng/ml HEK239 cells that contain a plasmid that expresses
20 an ERK-GFP fusion and varying amounts (from 0 to 300 ng/ml) of GFP (Clontech, cat#632373).

[0223] *Separation:* Five (5) cm sections of Teflon coated 100 micron ID capillaries were prepared as in U.S. patent serial No. 11/654,143 from commercially available capillaries (Polymicro Technologies, cat #TSU100375). It should be noted that capillaries prepared as
25 specified in the parent application to this application are also suitable. Capillary action was used to fill capillaries with sample. The capillaries were placed in custom electrophoresis tray containing anolyte and catholyte prepared as in O'Neill et al, *PNAS*, Vol. 103 (44). 16153-16158, and subjected to the following electrophoresis regime: 200 V for 200 sec, 400 V for 200 sec, 800 V for 1000 sec, and finally 800 V for 200 sec. This protocol will result in
30 proteins being resolved by their isoelectric focusing point (pI).

[0224] *Immobilization*: Half of the capillaries were subjected to immobilization by simply pouring hot water (nearly boiling) over the capillaries for 60 sec. The other half was used as no-immobilization controls.

5 [0225] *Washing and Probing*: After heat immobilization, capillaries were repeatedly washed with a TBST solution (10 mM Tris-HCl at pH 7.5, 150 mM NaCl, and 0.05% Tween20). Immobilized proteins were then incubated for 1 hr with anti-GFP primary antibodies (Invitrogen, cat# A1112) that had been diluted 1:2000 in TBST). This was followed by another TBST wash to remove non-specifically bound antibodies. Immobilized proteins were then incubated with HRP conjugated goat anti-rabbit secondary antibodies (Zymed, cat# 81-
10 6120 diluted to 1:4000 in TBST) for 10 mins. Capillaries were washed with TBST.

[0226] *Detection*: Chemiluminescence detection was performed by flowing West Femto Stable Peroxide buffer and Luminol/Enhancer solution (Pierce, cat# 1859023, 1859022) into the capillary and imaging the capillaries using a CCD camera (Princeton Instruments) for 30 sec. Images are stored in a 16 bit TIF file format as illustrated in FIG. 29. Data was extracted
15 from the image and analyzed using Igor Pro (Wave Metrics). The signal produced along the length of a capillary was extracted and plotted as signal versus capillary length. Graphs display chemiluminescent signal intensity on the 'Y' axis and pixel position (along the capillary) on the 'X' axis as shown in FIGs. 30 and 31.

[0227] *Results*: FIG. 29 is an Image 2900 showing a set of 6 capillaries prepared by
20 practicing embodiments of the present invention. The contents of a complex mixture of compounds, in this case a cell lysate, were resolved, immobilized and probed with detection reagents resulting in the detection of analytes. The analyte detected in this case was an ERK-GFP fusion protein. The detection was conducted by flowing an antibody to GFP through the capillary so that it came in contact with the ERK-GFP that was immobilized. A secondary
25 antibody against the first contained horse radish peroxidase attached to it, an enzyme commonly used in well established chemiluminescent detection applications. When luminol and peroxide are then flowed through the capillary, light is produced at the location of the analyte 2915.

[0228] A second protein rGFP was added to the sample. As increasing amounts of rGFP
30 were added, a new peak 2913 could be seen in the images. Neither peak was visible in samples that were not treated with heat, image 2920. Graphs showing data extracted from the

TIF images used to produce 2900 and 2920 of FIG. 29 are shown in FIGS. 30 and 31. These graphs show that the signals from the analytes are hundreds of times greater than that produces when the samples were not exposed to heat.

[0229] More specifically, FIG. 29 depicts two (2) images 2900 and 2920 demonstrating immobilization of a target analyte is induced by exposure to heat. The contrast of the images has been adjusted to allow visualization of background signal so that the location of the capillaries could be visualized. The capillaries in the two images are identical except that the capillaries in image 2900 were exposed to heat and the capillaries in image 2920 were not. All capillaries contain 38 $\mu\text{g/ml}$ of a cell lysate that expressed an ERK-GFP fusion protein. Capillaries from top to bottom contain increasing amounts of recombinant GFP: 0ng/ml (2901 and 2907), 20 ng/ml (2902 and 2908), 40 ng/ml (2903 and 2909), 80 ng/ml (2904 and 2910), 150 ng/ml (2905 and 2911), and 300 ng/ml (2906 and 2912).

[0230] Turning again to FIGs. 30 and 31, Figure 30 shows graphs of the data extracted from the TIF images used to produce FIG. 29. Specifically, data from heated capillary 2901 is shown as solid line 3001 and data from unheated control capillary 2907 is shown as dashed line 3002. The analyte, ERK-GFP was clearly immobilized by heat as shown by a peak that is several hundred times the background signal or the signal seen in the unheated control.

[0231] FIG. 31 shows graphs of the data extracted from the TIF images used to produce FIG. 29. Specifically the data from heated capillary 2903 is shown as solid line 3101 and data from unheated control capillary 2909 is shown as dashed line 3102. The data shows a peak signal 3103 not seen in samples in which GFP was not added (FIG. 30), confirming that the anti-GFP antibody is performing as expected and that the other peak (3104) corresponds to ERK-GFP. The presence of both peaks is dependent on heat to immobilize the analytes within the fluid path for probing with the detection reagents, as seen by the absence of peaks in data extracted from capillary 2909, dashed line 3102.

[0232] The foregoing descriptions of specific embodiments of the present invention have been presented for purposes of illustration and description. They are not intended to be exhaustive or to limit the invention to the precise forms disclosed, and obviously many modifications and variations are possible in light of the above teaching. The embodiments were chosen and described in order to best explain the principles of the invention and its practical application, to thereby enable others skilled in the art to best utilize the invention

and various embodiments with various modifications as are suited to the particular use contemplated. It is intended that the scope of the invention be defined by the Claims appended hereto and their equivalents.

5 [0233] All patents, patent applications, publications, and references cited herein are expressly incorporated by reference to the same extent as if each individual publication or patent application was specifically and individually indicated to be incorporated by reference.

We claim:

1. A method of detecting one or more analytes in a sample, said method comprising:
 - resolving said analytes in a fluid path based on the size of said one or more
5 analytes;
 - immobilizing said analytes in said fluid path;
 - conveying detection reagents through said fluid path; and
 - detecting one or more analytes by measuring the signal generated by said
detection reagents.
- 10 2. The method according to claim 1, wherein said analytes comprise proteins.
3. The method according to claim 1, wherein said sample further comprises a
standard.
4. The method according to claim 1, wherein said sample is introduced into the
fluid path by hydrodynamics.
- 15 5. The method according to claim 1, wherein said sample is introduced into the
fluid path by electrokinetic injection.
6. The method according to claim 1 wherein said fluid path is comprised of one
or more capillaries.
7. The method according to claim 1 wherein said analytes are resolved by
20 electrophoresis.
8. The method according to claim 1, wherein said fluid path comprises a sieving
matrix.
9. The method according to claim 1, wherein said fluid path comprises a
detergent.
- 25 10. The method according to claim 1, wherein said immobilization is achieved by
photoactivated chemistry.
11. The method according to claim 1 wherein said detection reagents are
comprised of antibodies.

12. A method of detecting one or more analytes in a sample, said method comprising:
- resolving said analytes in a fluid path;
 - immobilizing said analytes in the fluid path by heating the fluid path;
 - 5 conveying detection reagents through the fluid path; and
 - detecting said analyte by measuring the signal generated by said detection reagents.
13. The method according to claim 12, wherein said analytes are resolved by electrophoresis.
- 10 14. The method according to claim 12 where the fluid path comprises a sieving matrix.
15. The method according to claim 12, wherein said fluid path is comprised of one or more capillaries.
16. The method according to claim 12, wherein said sample is introduced into said
15 fluid path by hydrodynamics.
17. The method according to claim 12, wherein said sample is introduced into said fluid path by electrokinetic injection.
18. The method according to claim 12, wherein said detection reagents are comprised of antibodies.
- 20 19. A device capable of detecting one or more analytes in a sample, said device comprising:
- a fluid path for resolving said analytes;
 - a means of immobilizing said analytes in said fluid path;
 - a means of conveying detection reagents through said fluid path; and
 - 25 a means of measuring the signal generated by said detection reagents.
20. The device according to claim 19, wherein said fluid path is comprised of one or more capillaries.

21. The device according to claim 19, wherein said means of resolving said analytes is electrophoresis.
22. The device according to claim 19, wherein said fluid path comprises a sieving matrix.
- 5 23. The device according to claim 19, further comprising a means of introducing said sample into the fluid path.
24. The device according to claim 19 wherein said means of immobilizing said analytes is by a temperature change.
- 10 25. The device according to claim 24 wherein said means of immobilizing said analytes is by heating the fluid path.

1/24

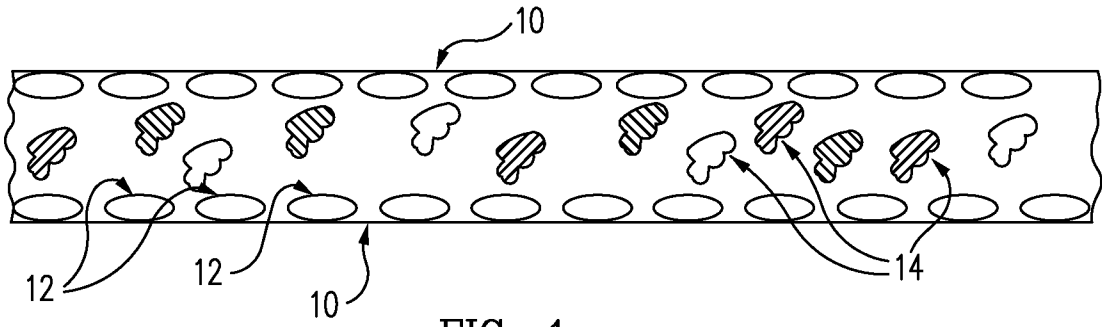

FIG. 1a

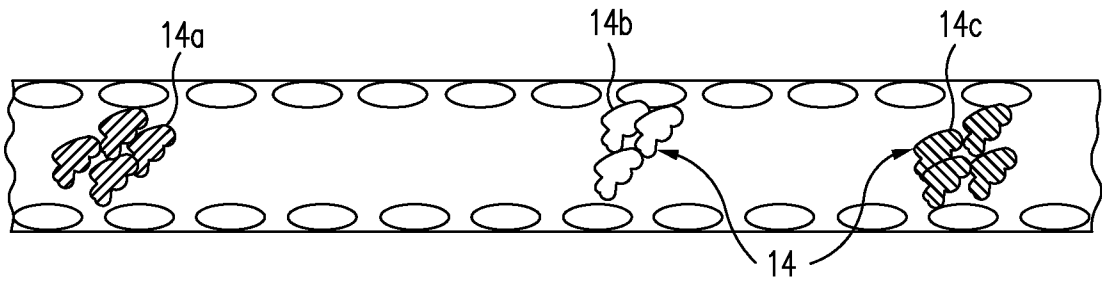

FIG. 1b

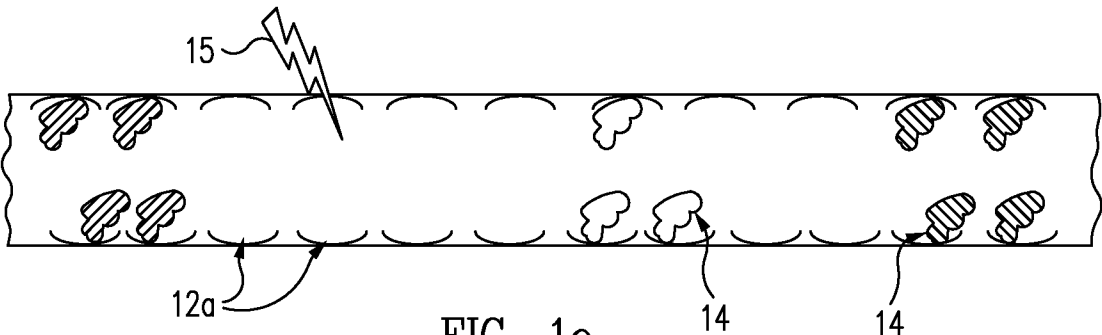

FIG. 1c

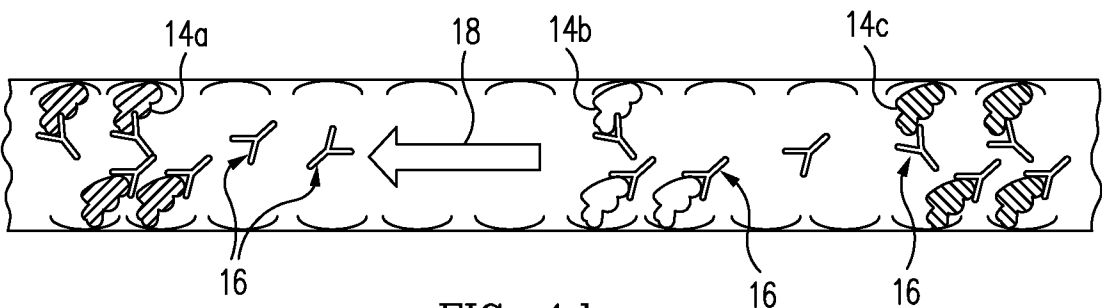

FIG. 1d

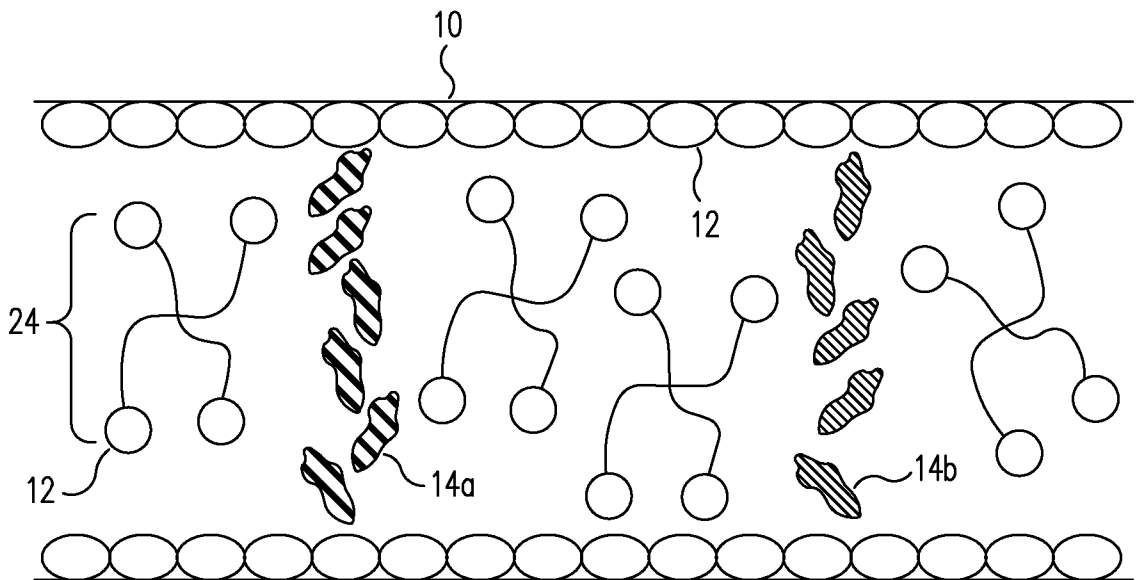

FIG. 2a

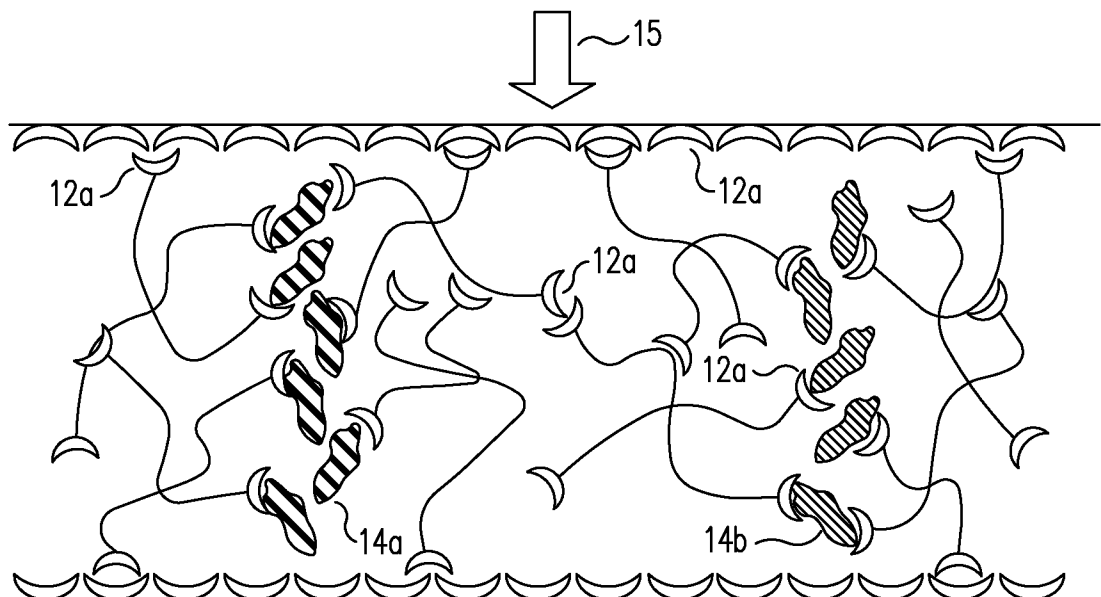

FIG. 2b

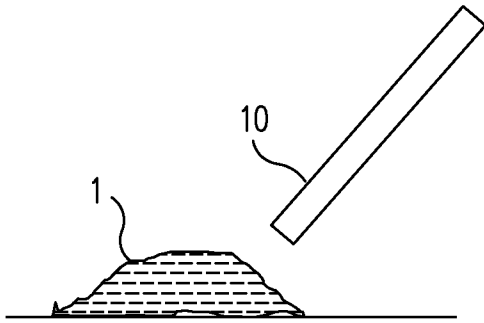

FIG. 3a

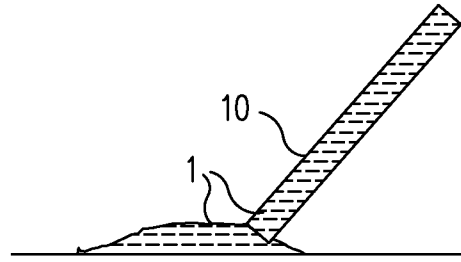

FIG. 3b

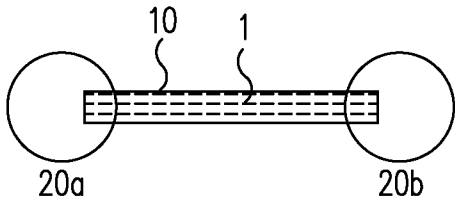

FIG. 3c

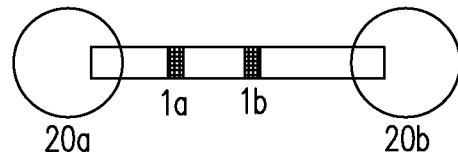

FIG. 3d

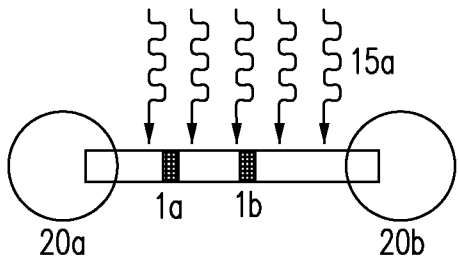

FIG. 3e

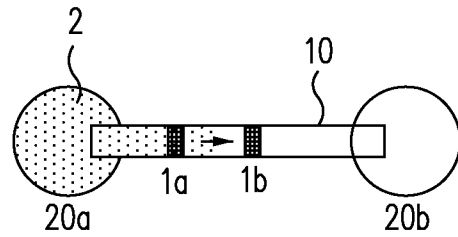

FIG. 3f

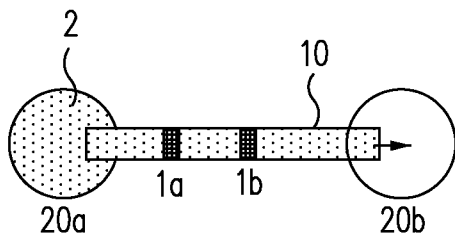

FIG. 3g

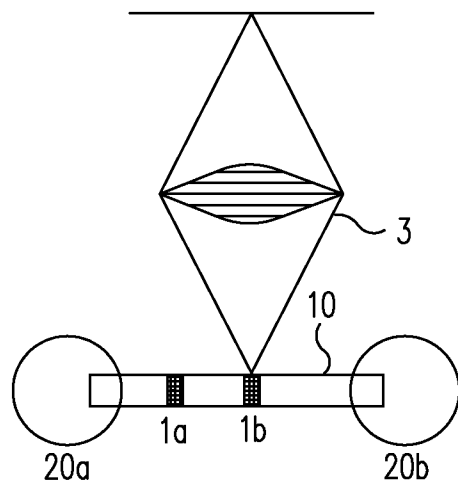

FIG. 3h

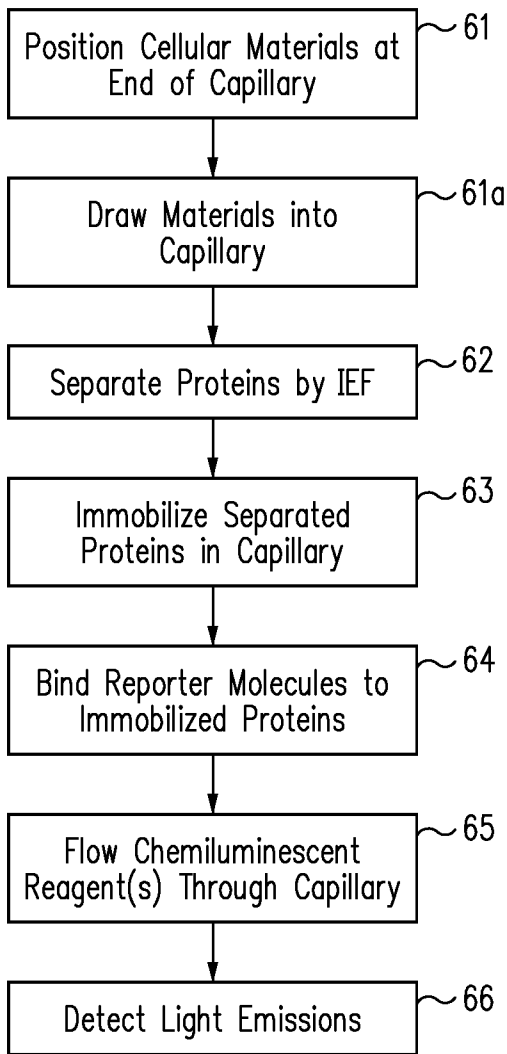

FIG. 4

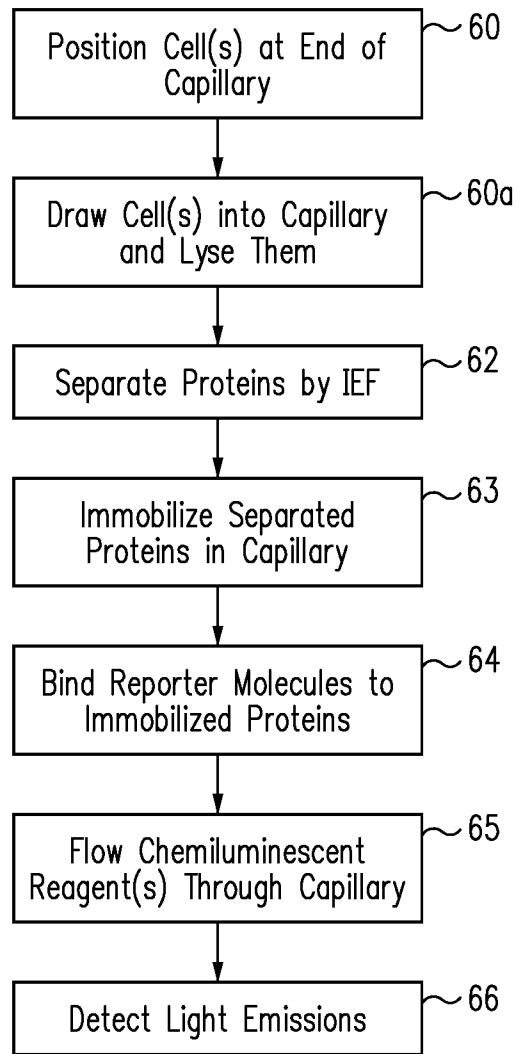

FIG. 5

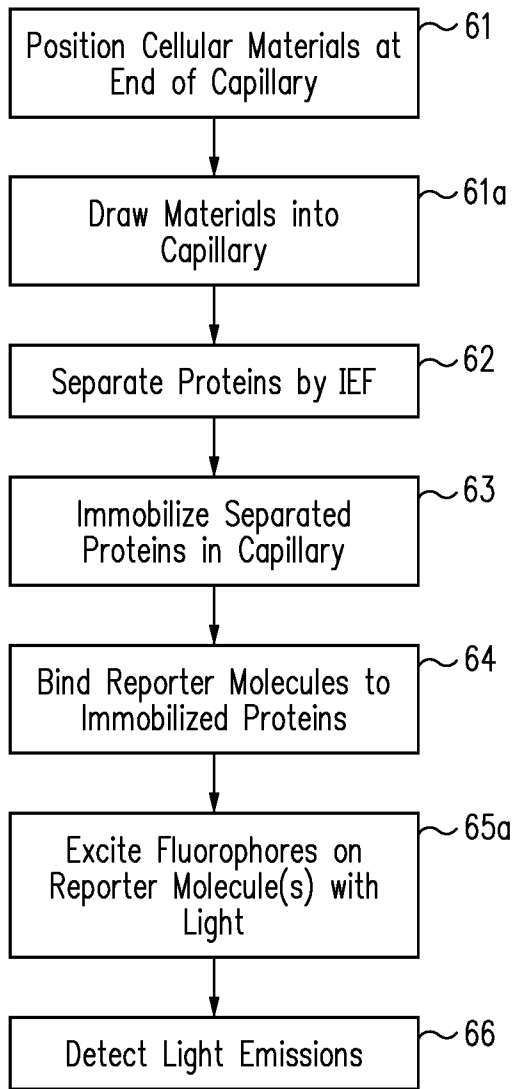

FIG. 6

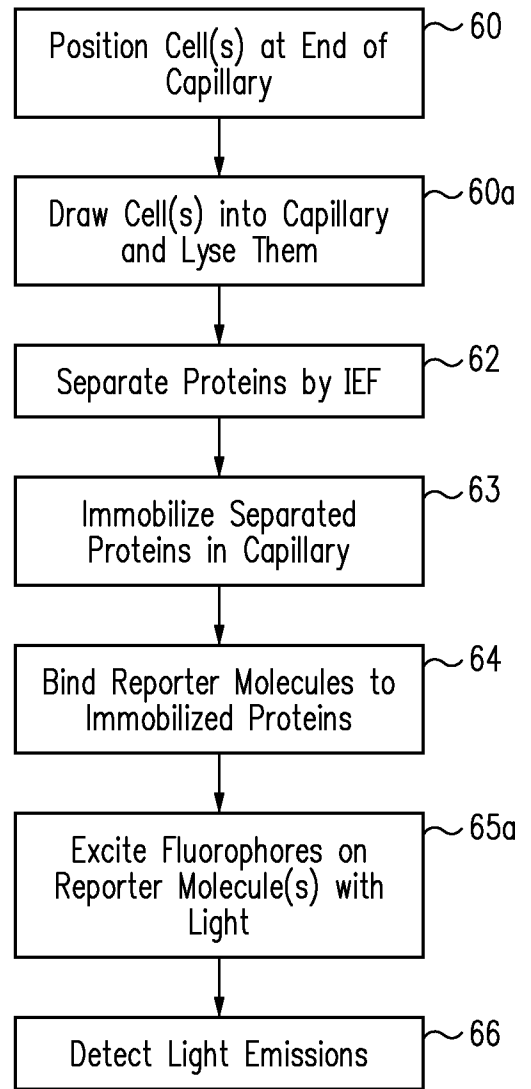

FIG. 7

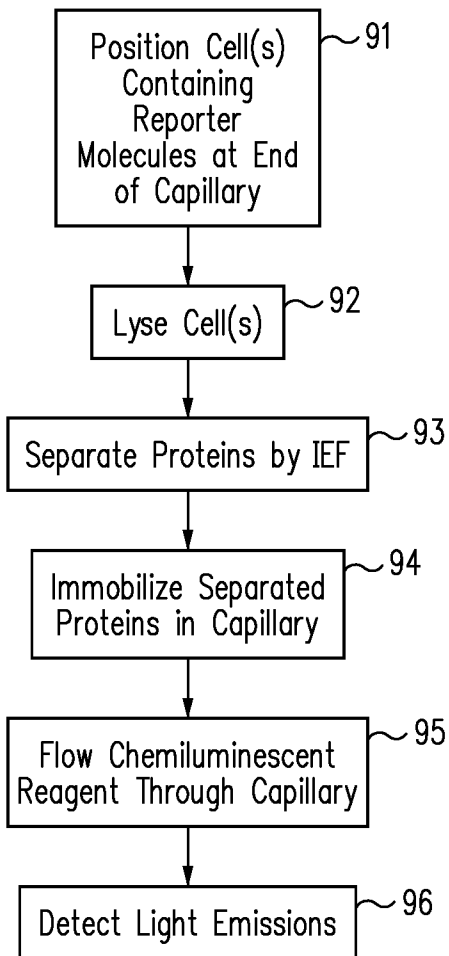

FIG. 8

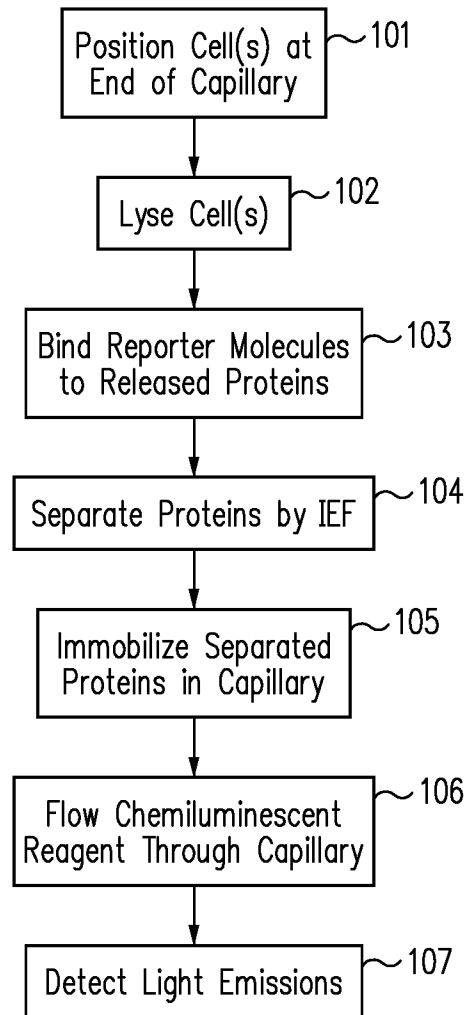

FIG. 9

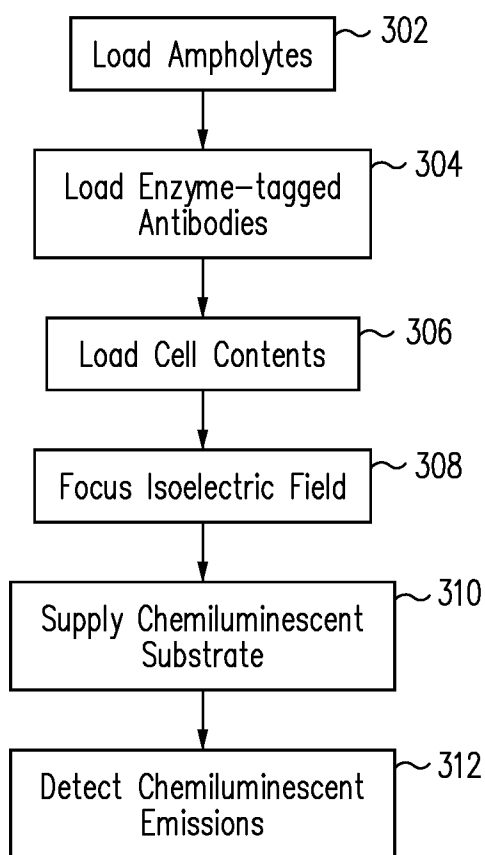

FIG. 10

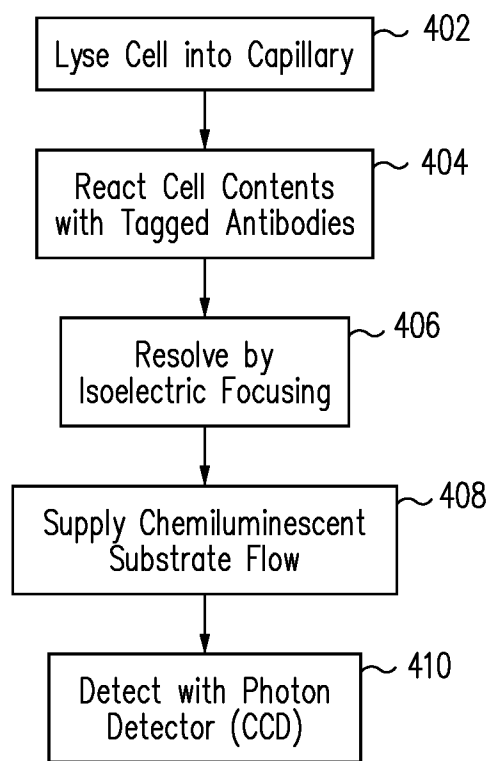

FIG. 11

8/24

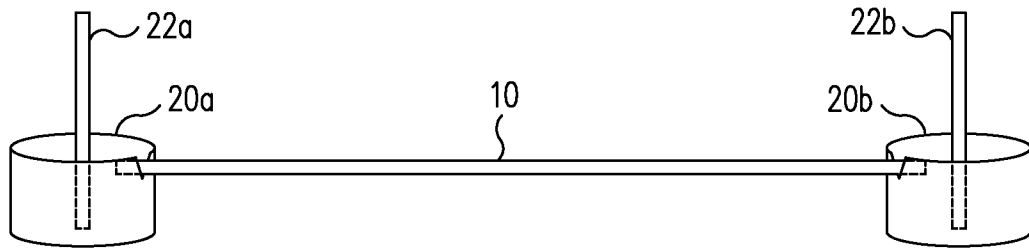

FIG. 12a

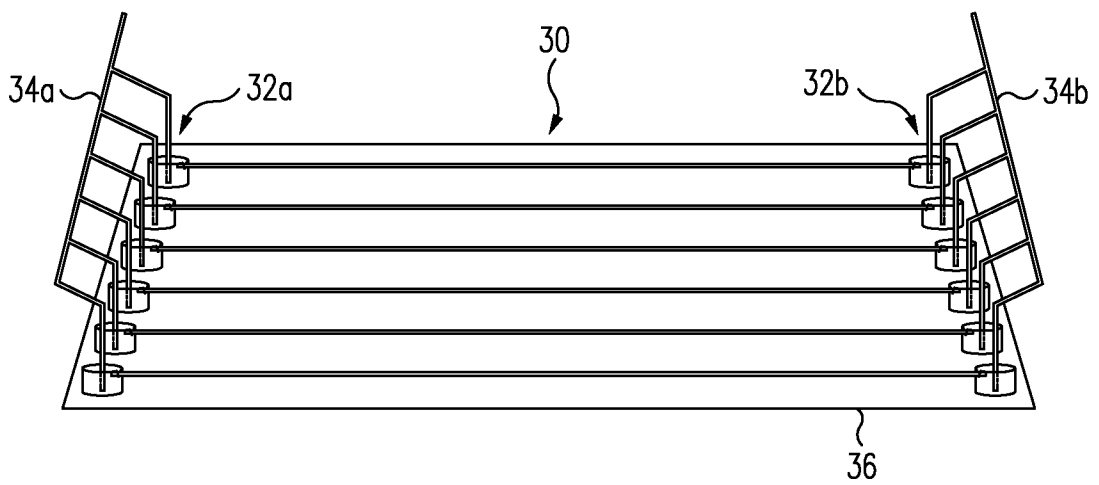

FIG. 12b

9/24

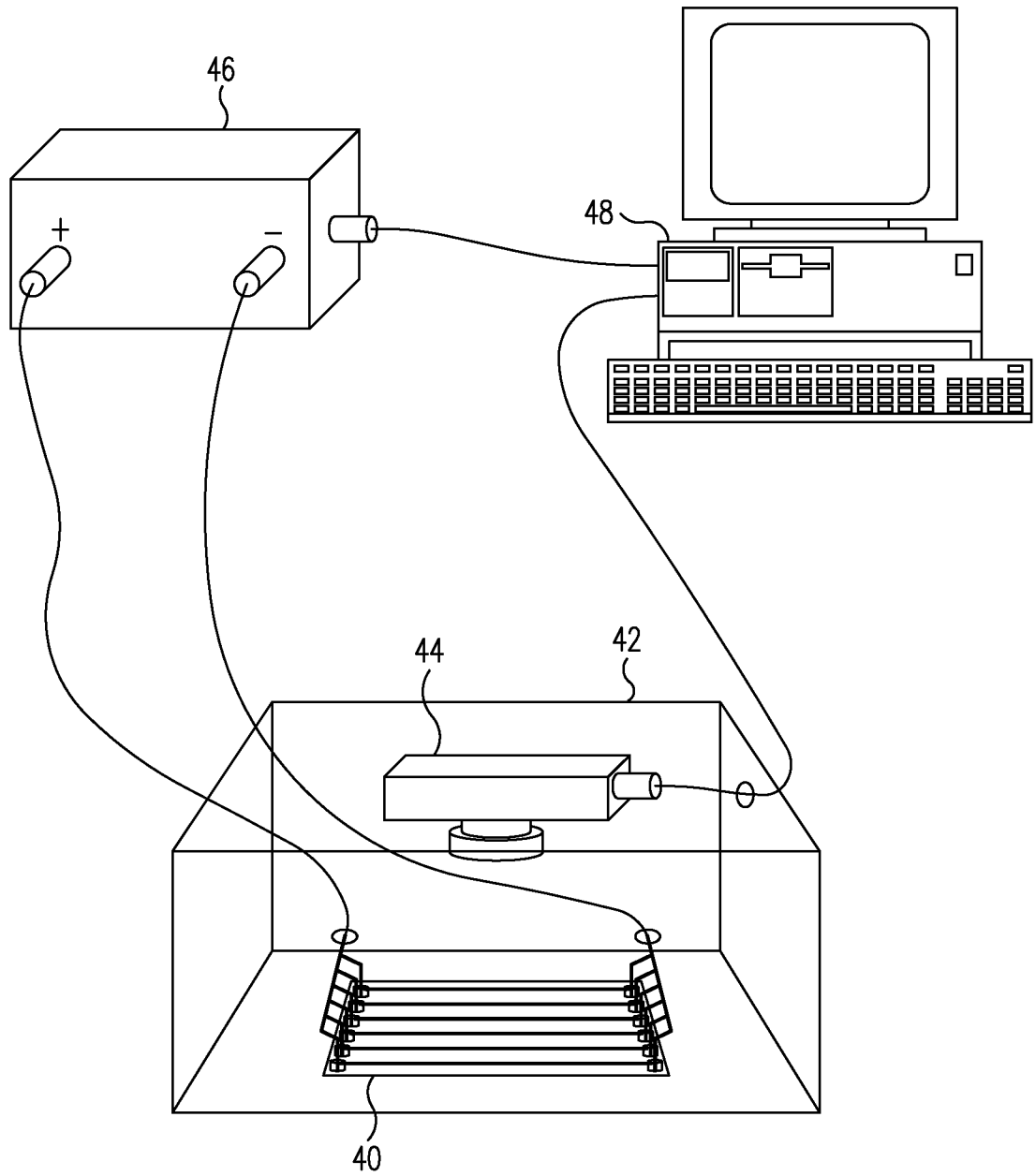

FIG. 14

10/24

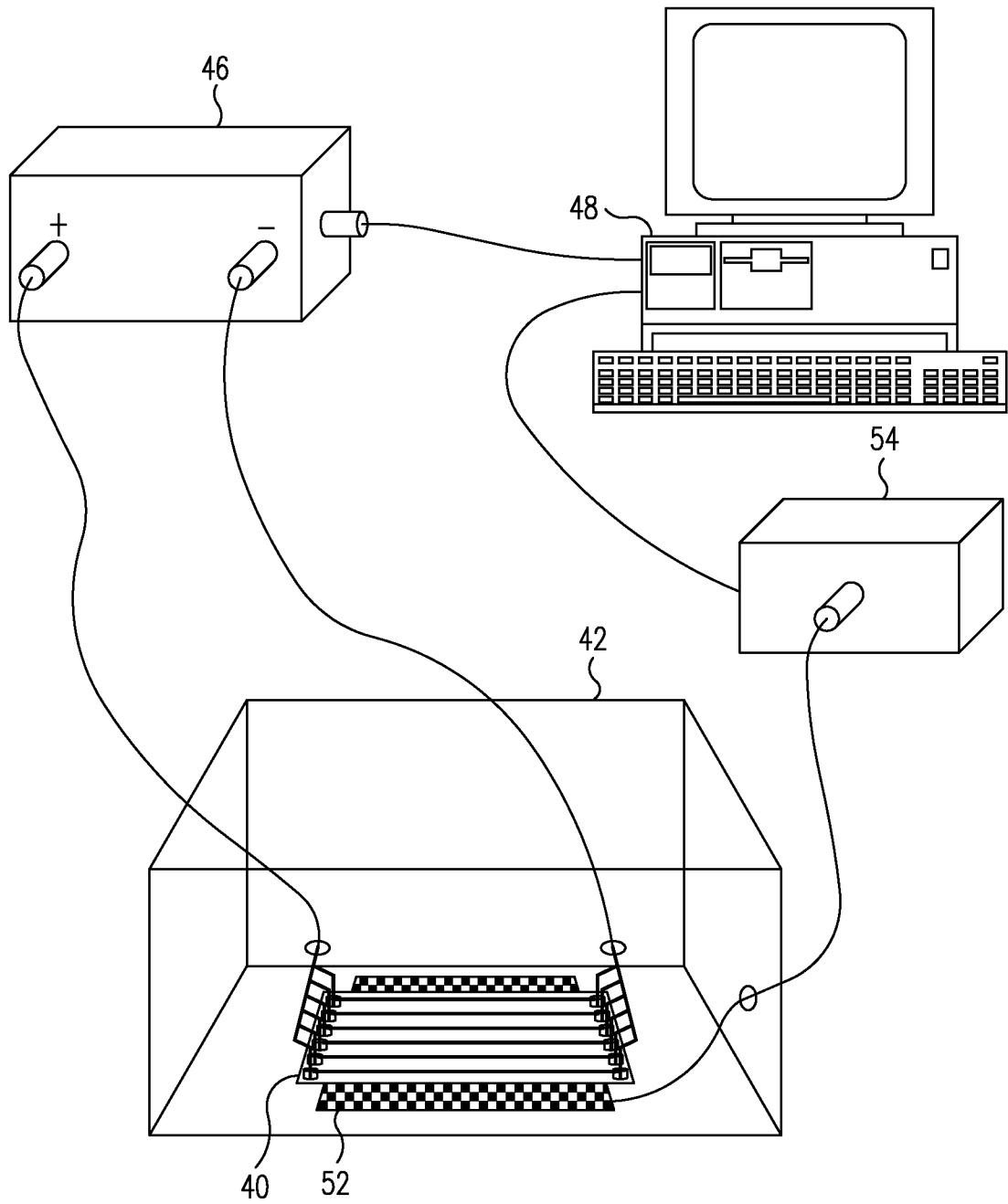

FIG. 15

11/24

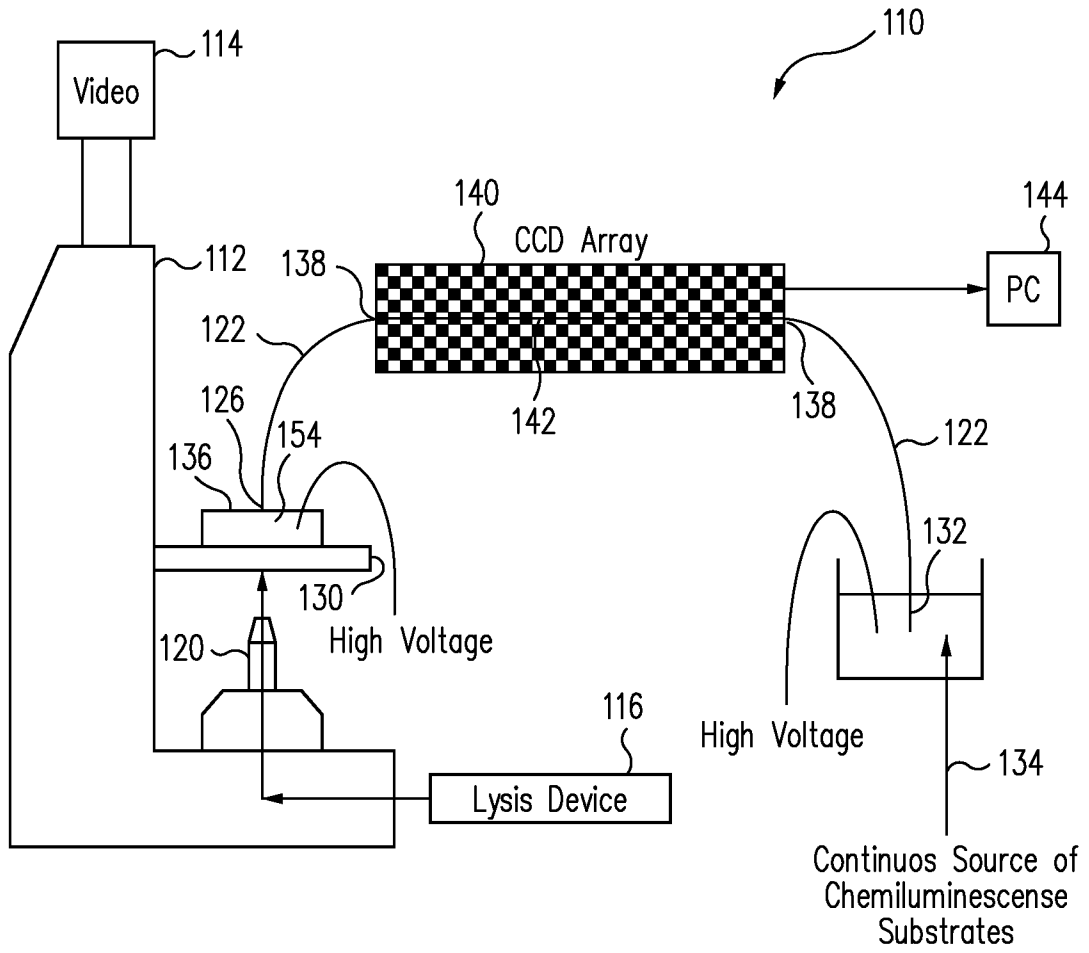

FIG. 16

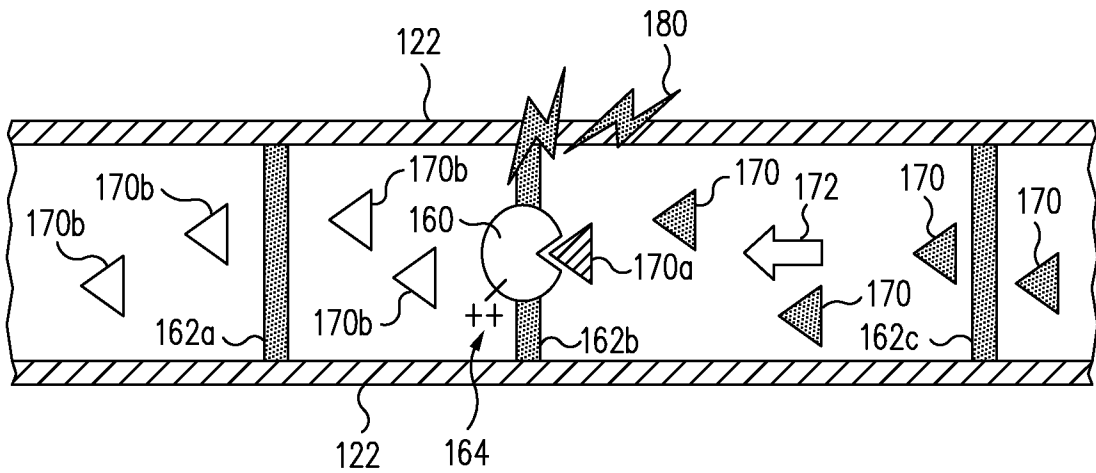

FIG. 13

12/24

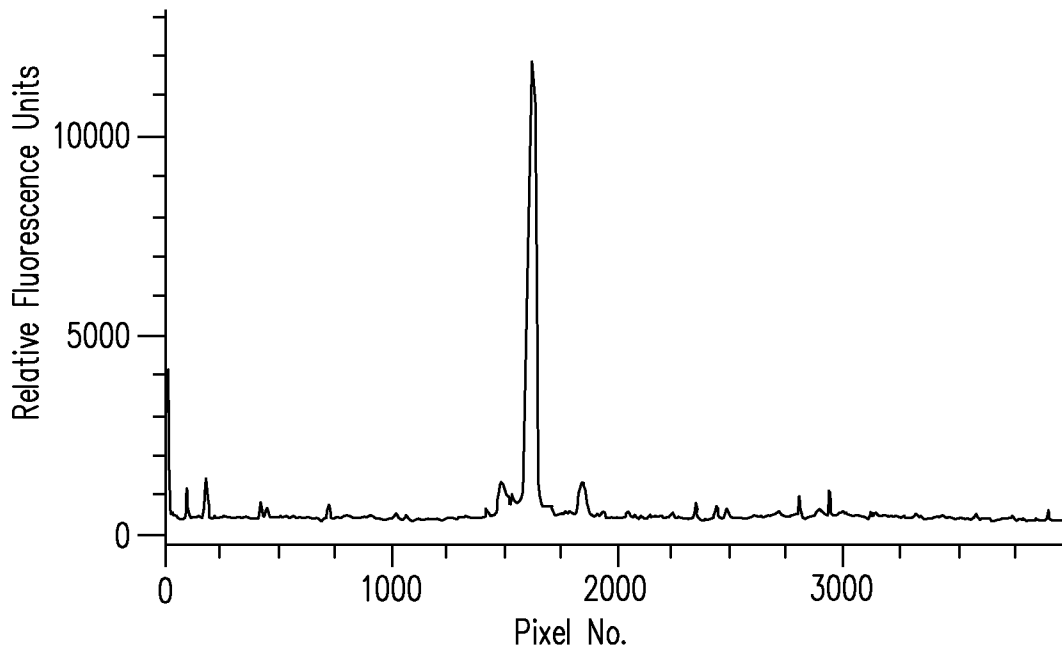

FIG. 17

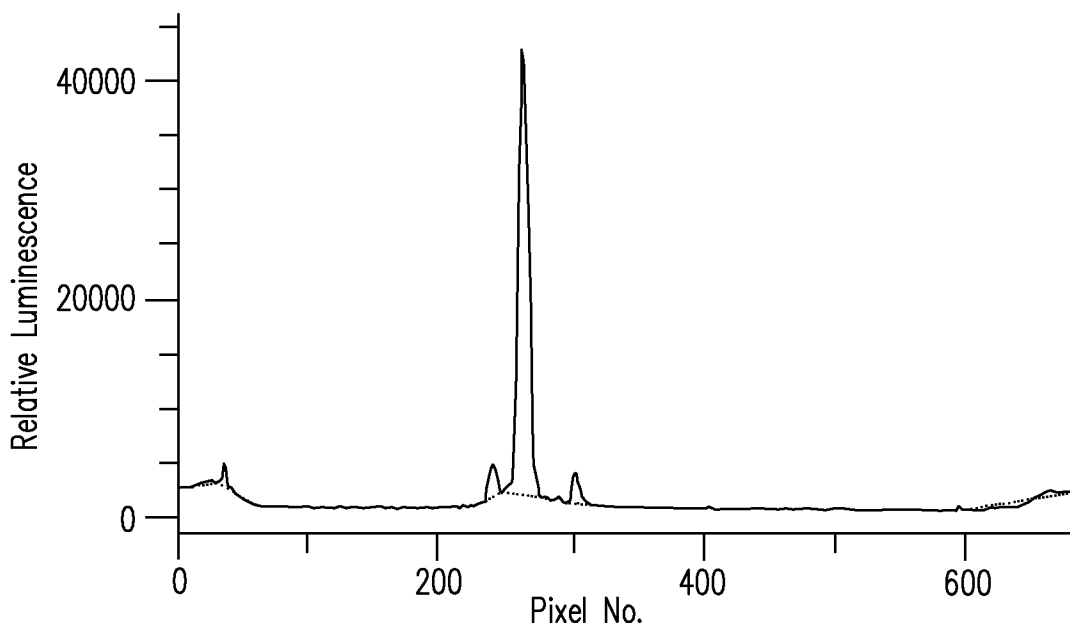

FIG. 18

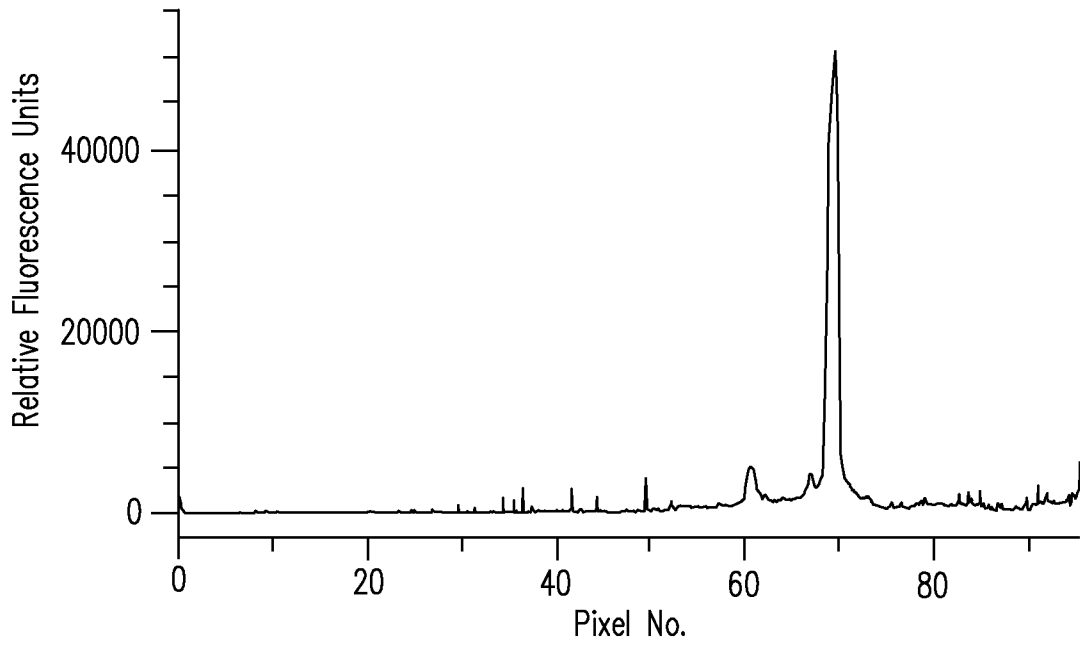

FIG. 19

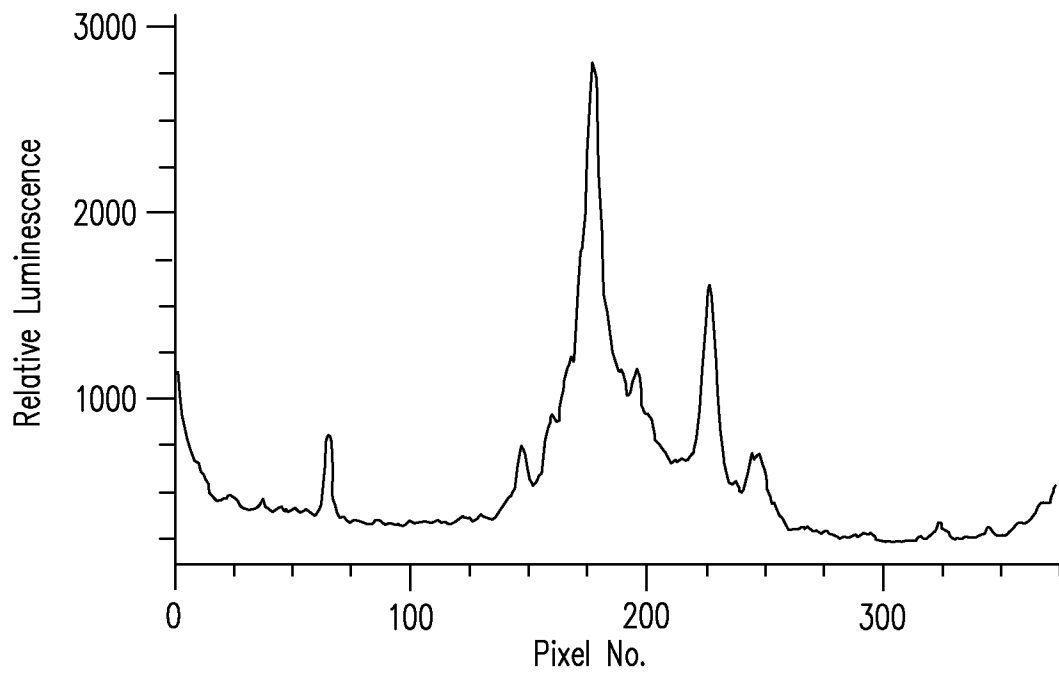

FIG. 20

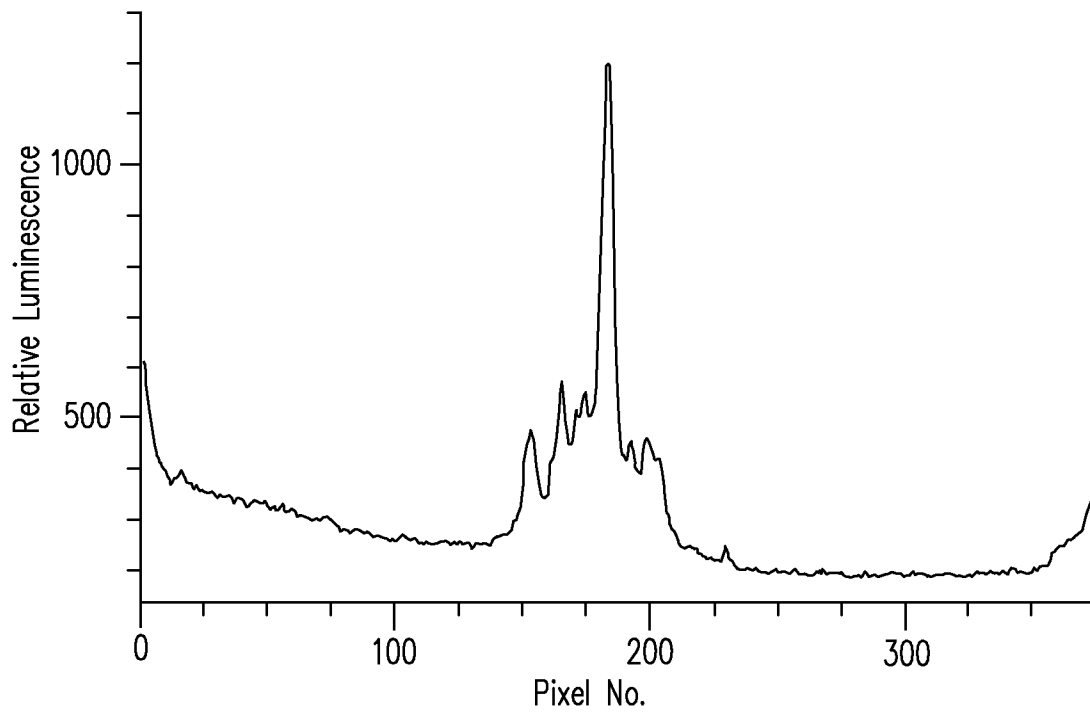

FIG. 21

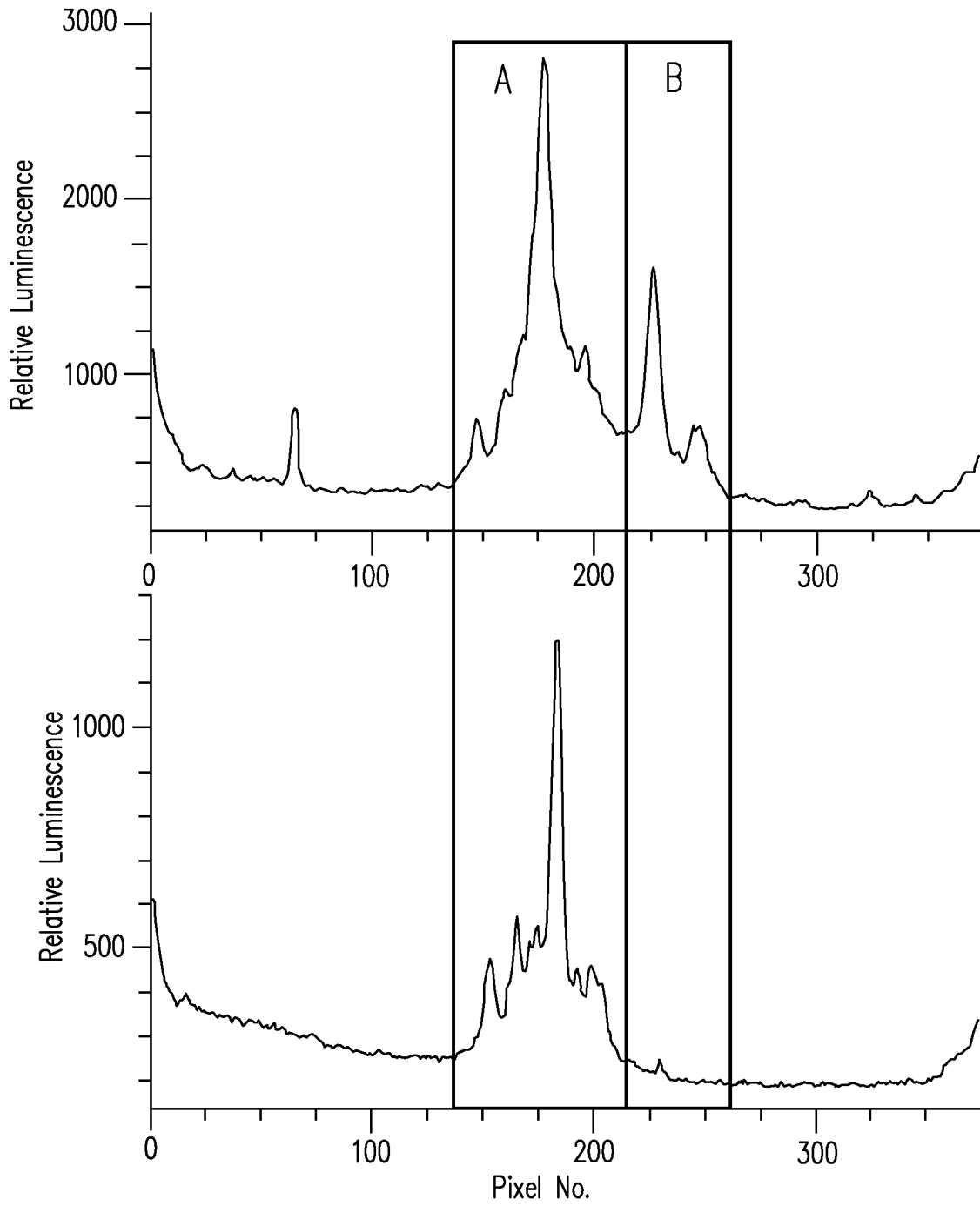

FIG. 22

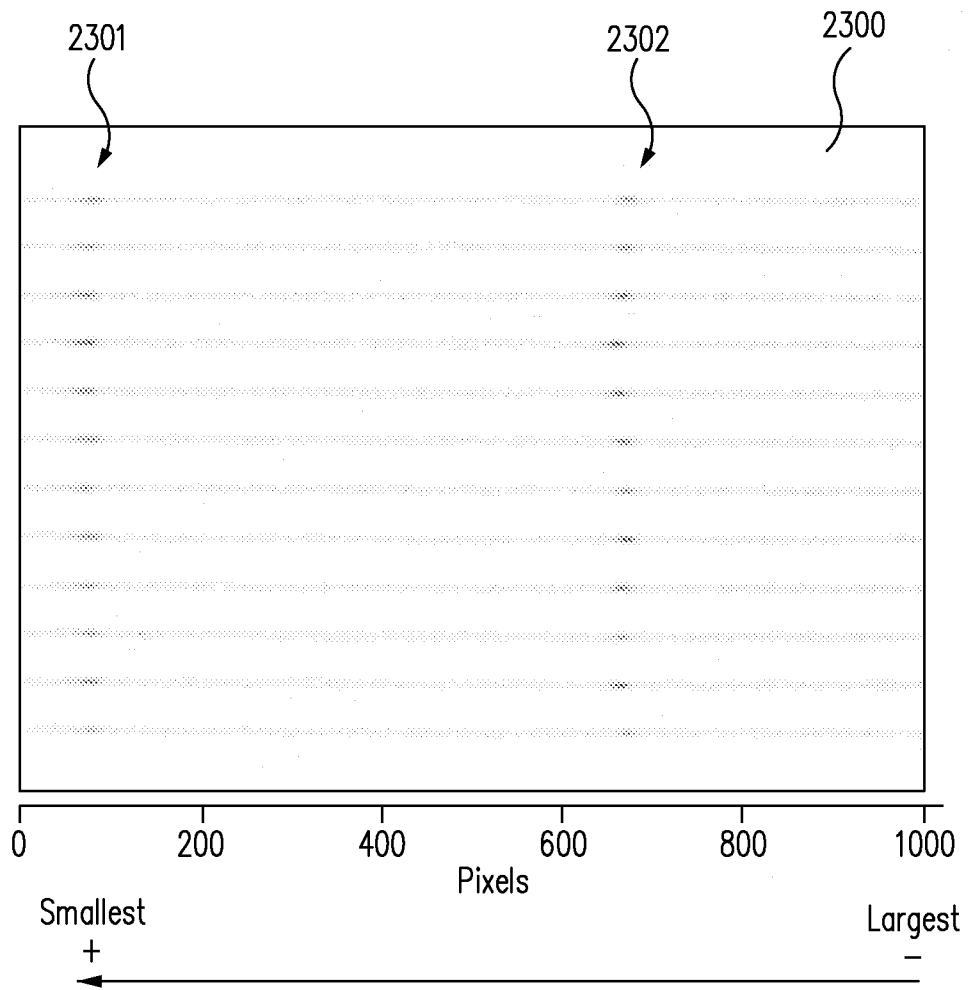

FIG. 23

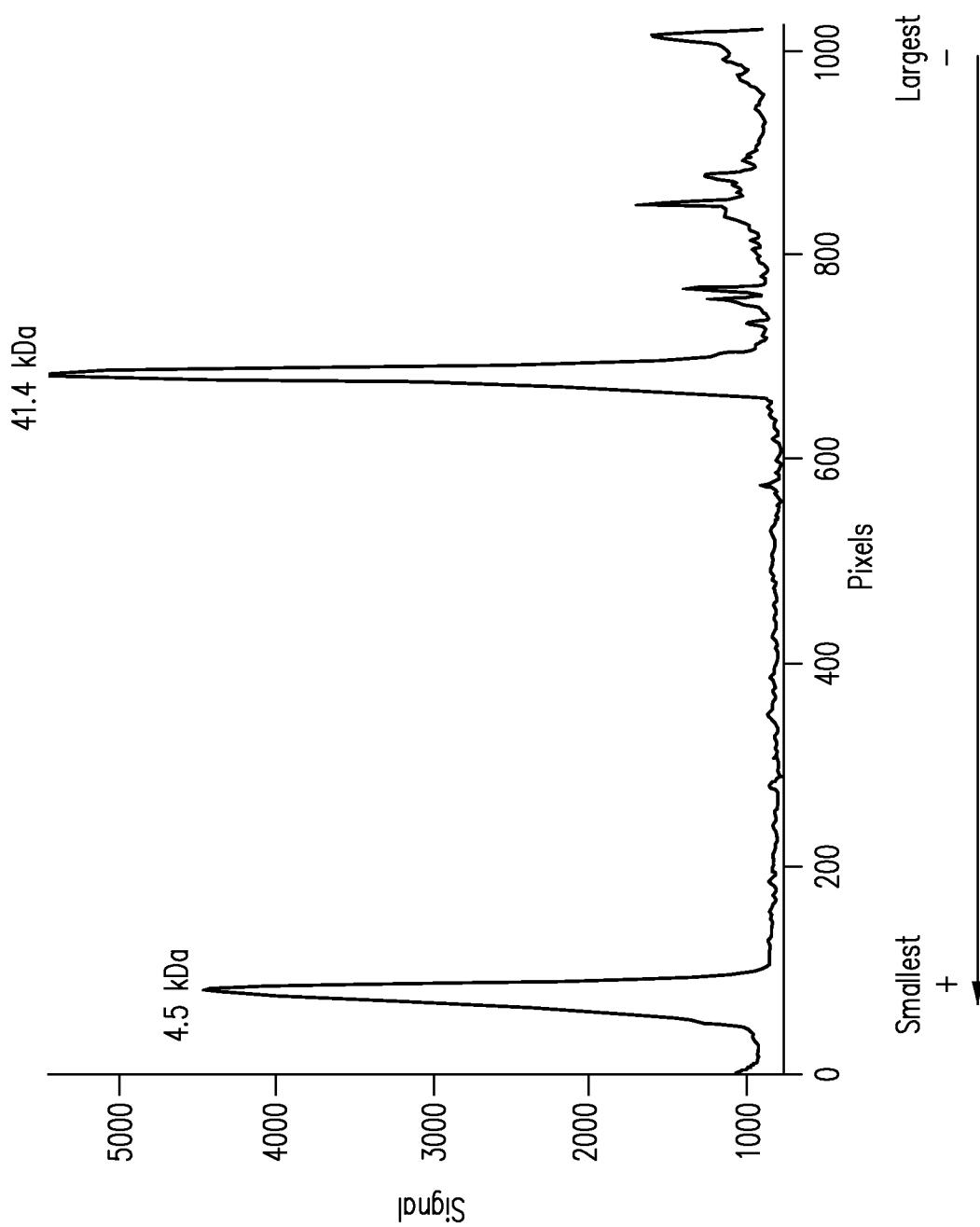

FIG. 24

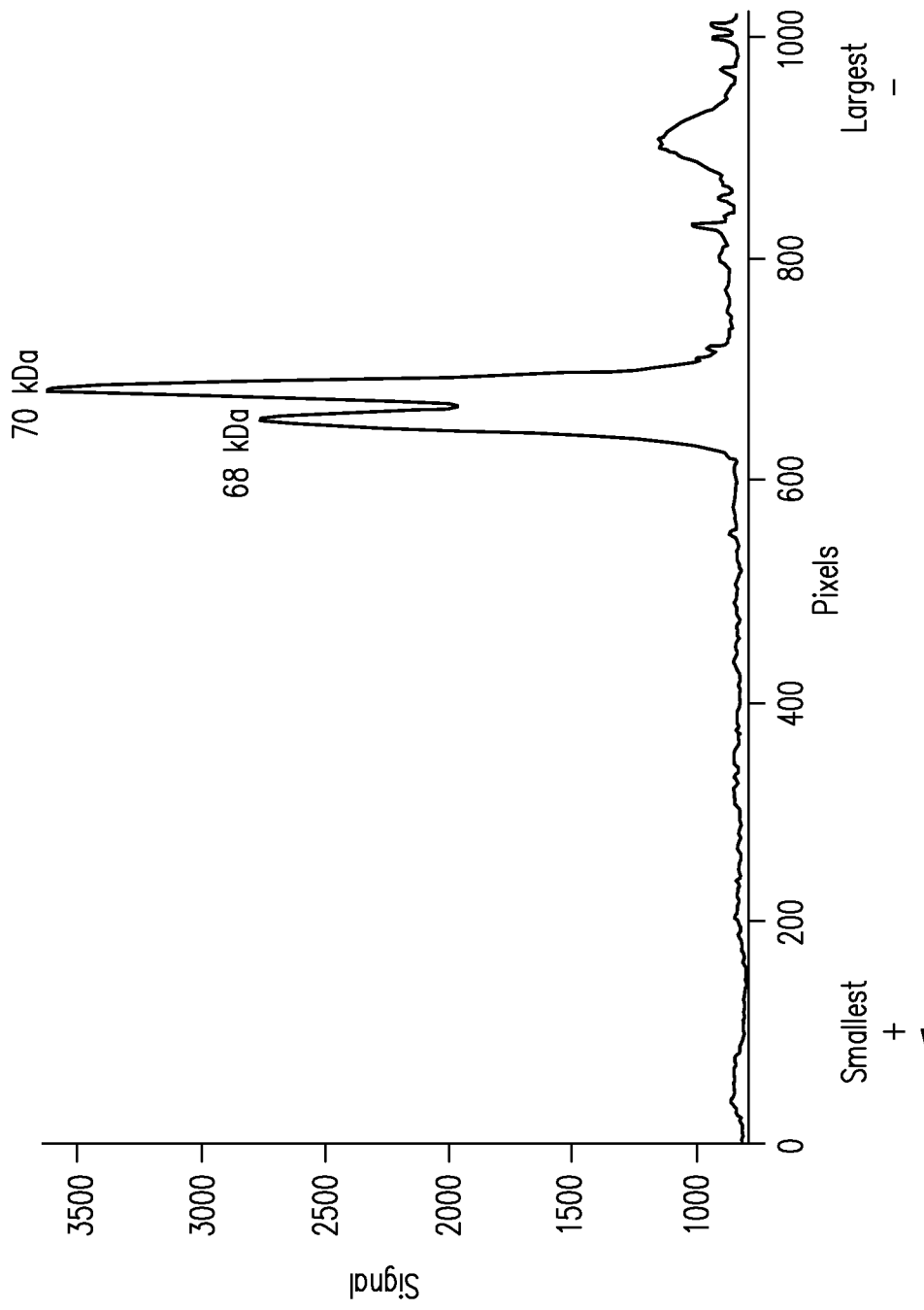

FIG. 25

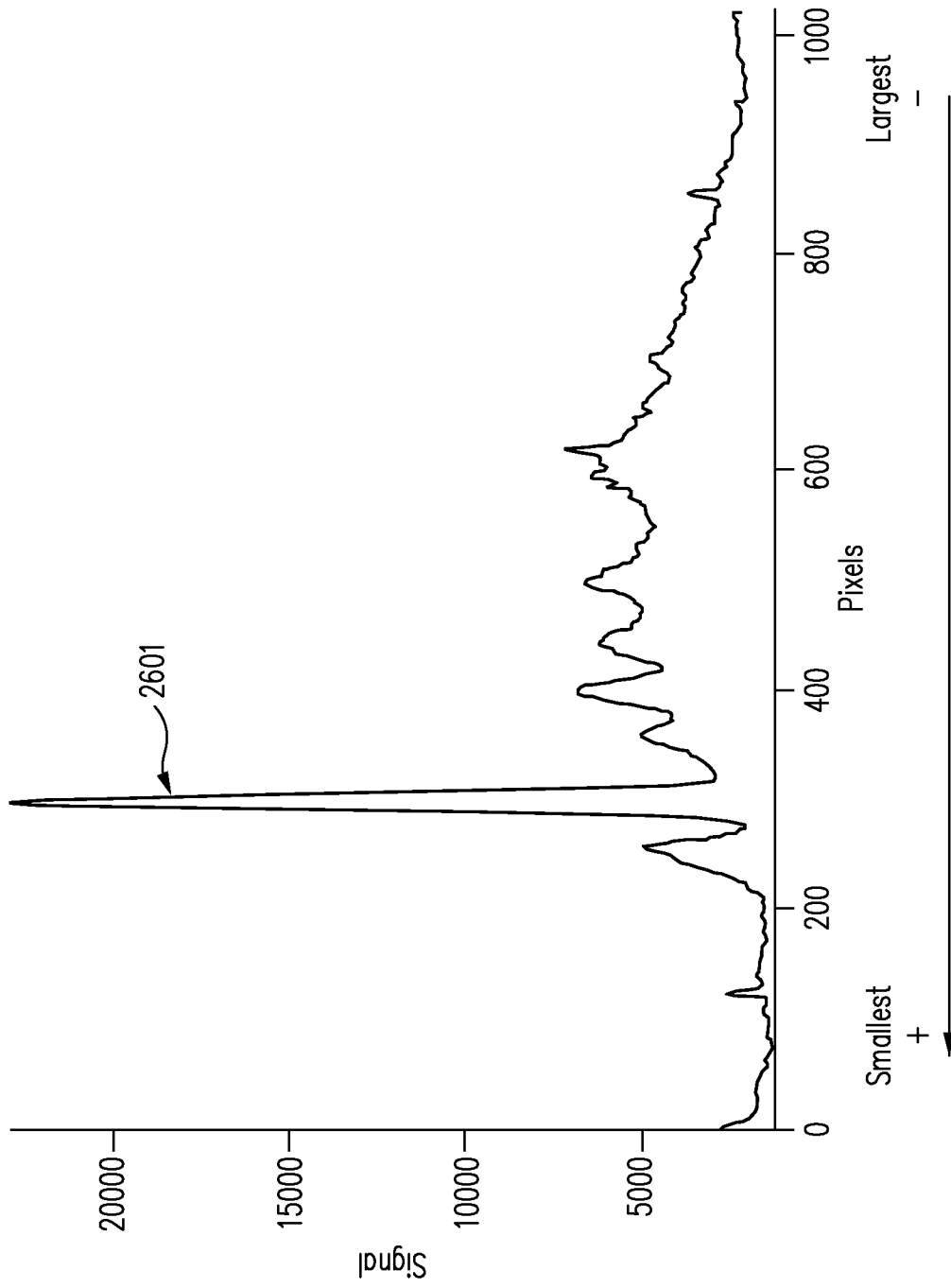

FIG. 26

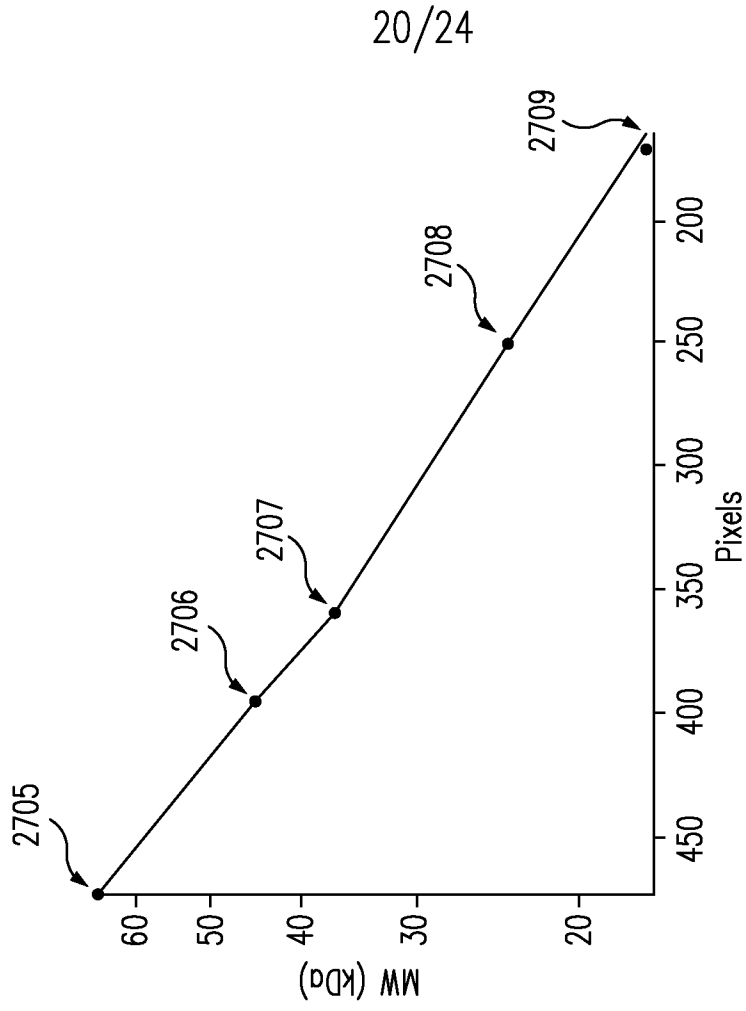

FIG. 27B

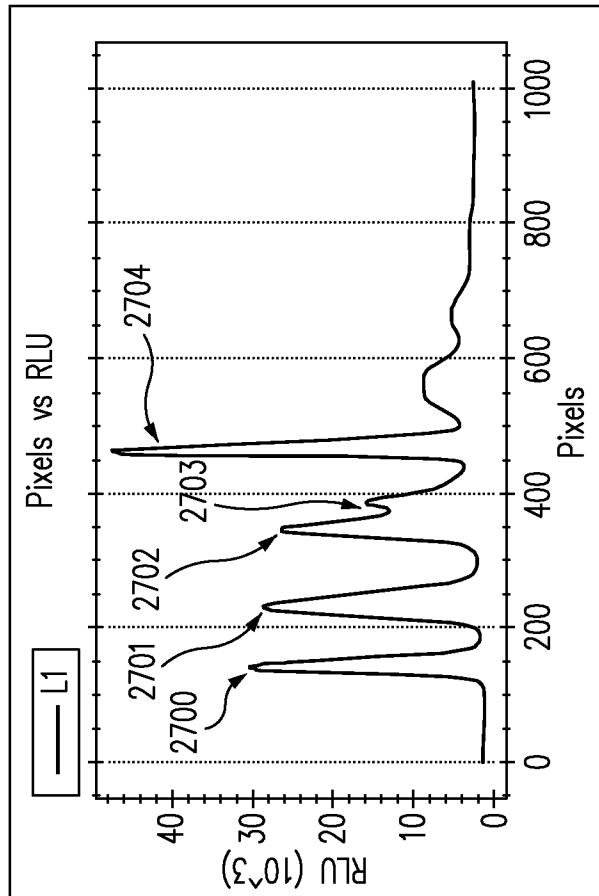

FIG. 27A

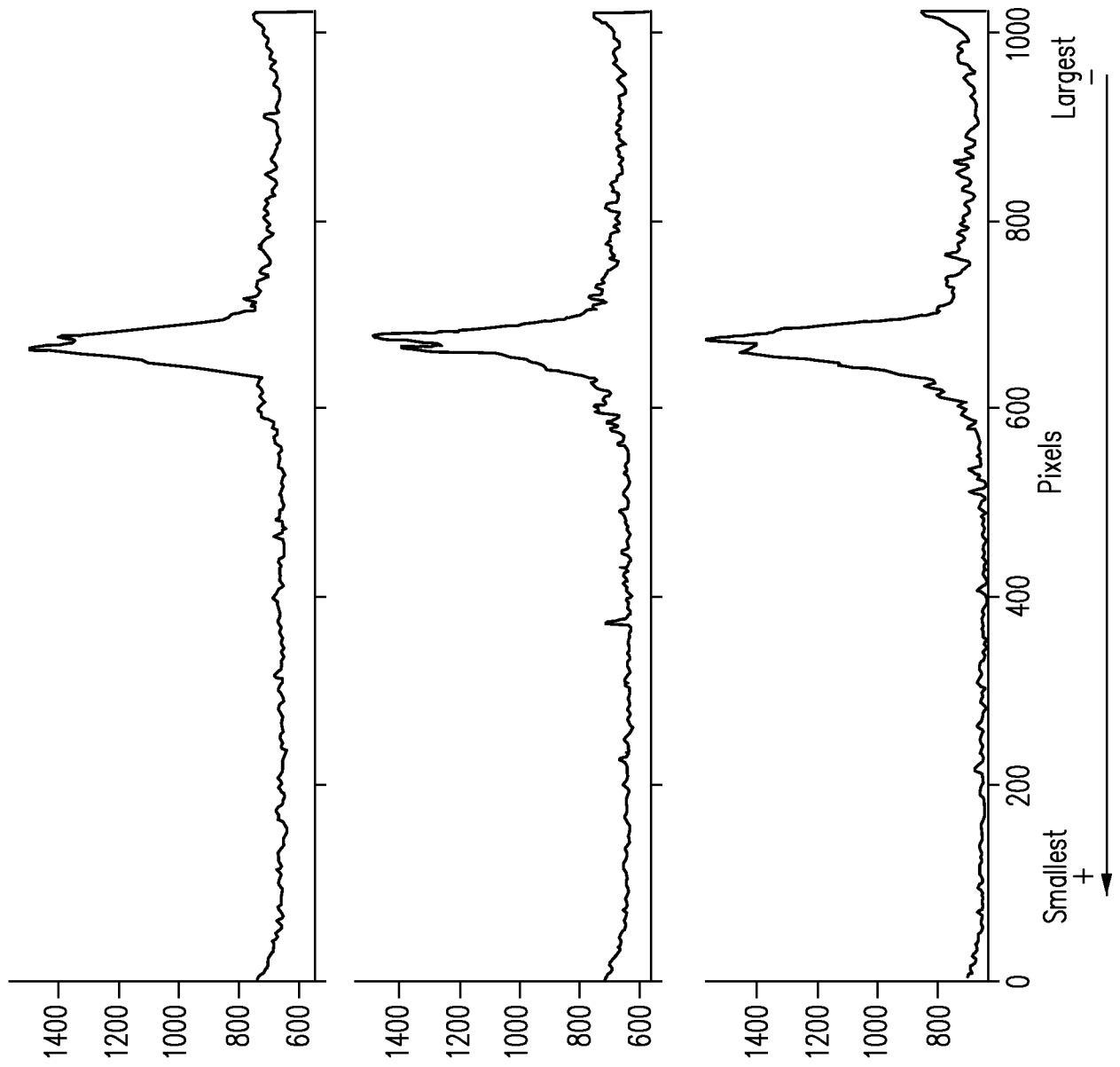

FIG. 28

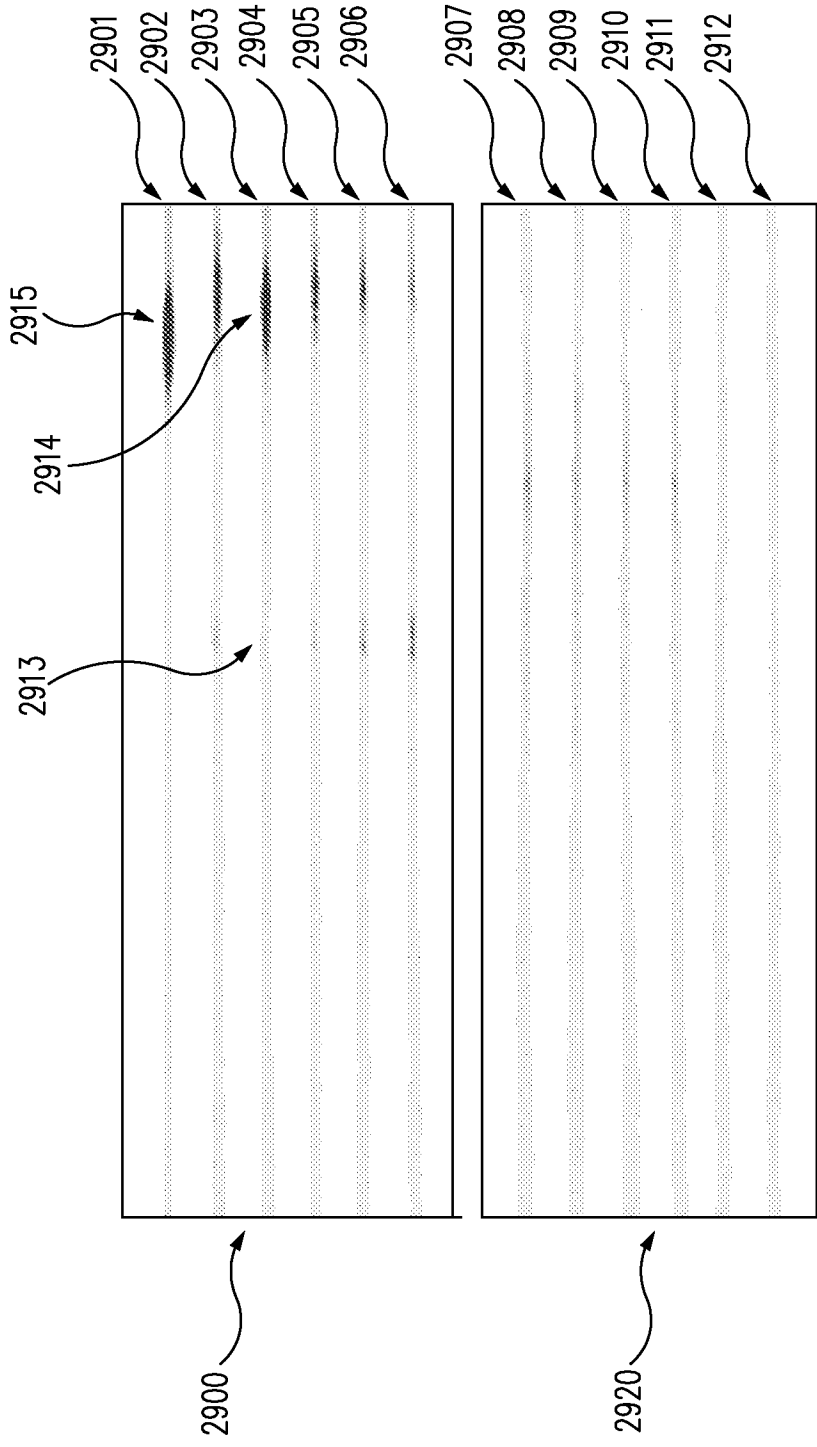

FIG. 29

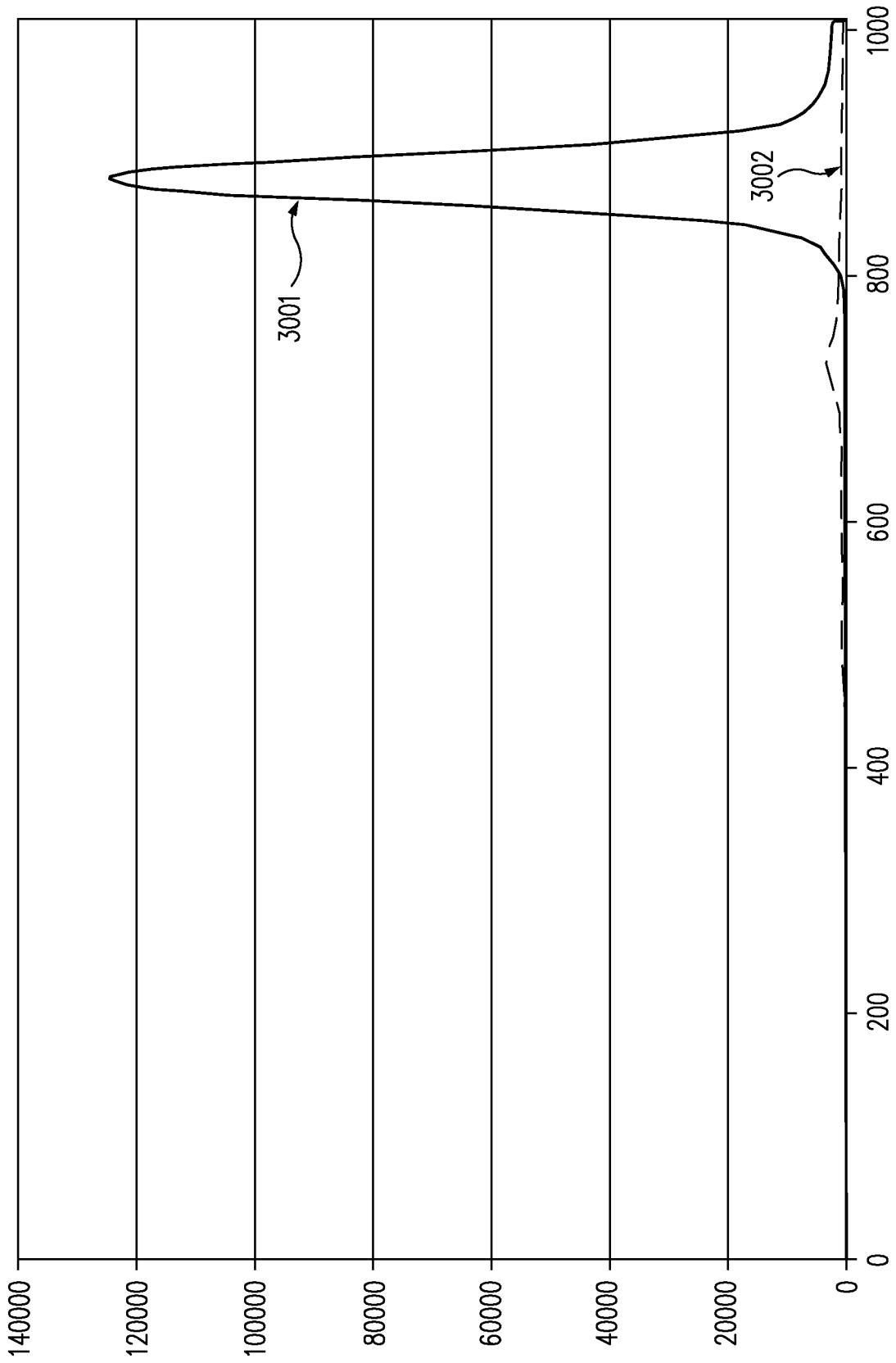

FIG. 30

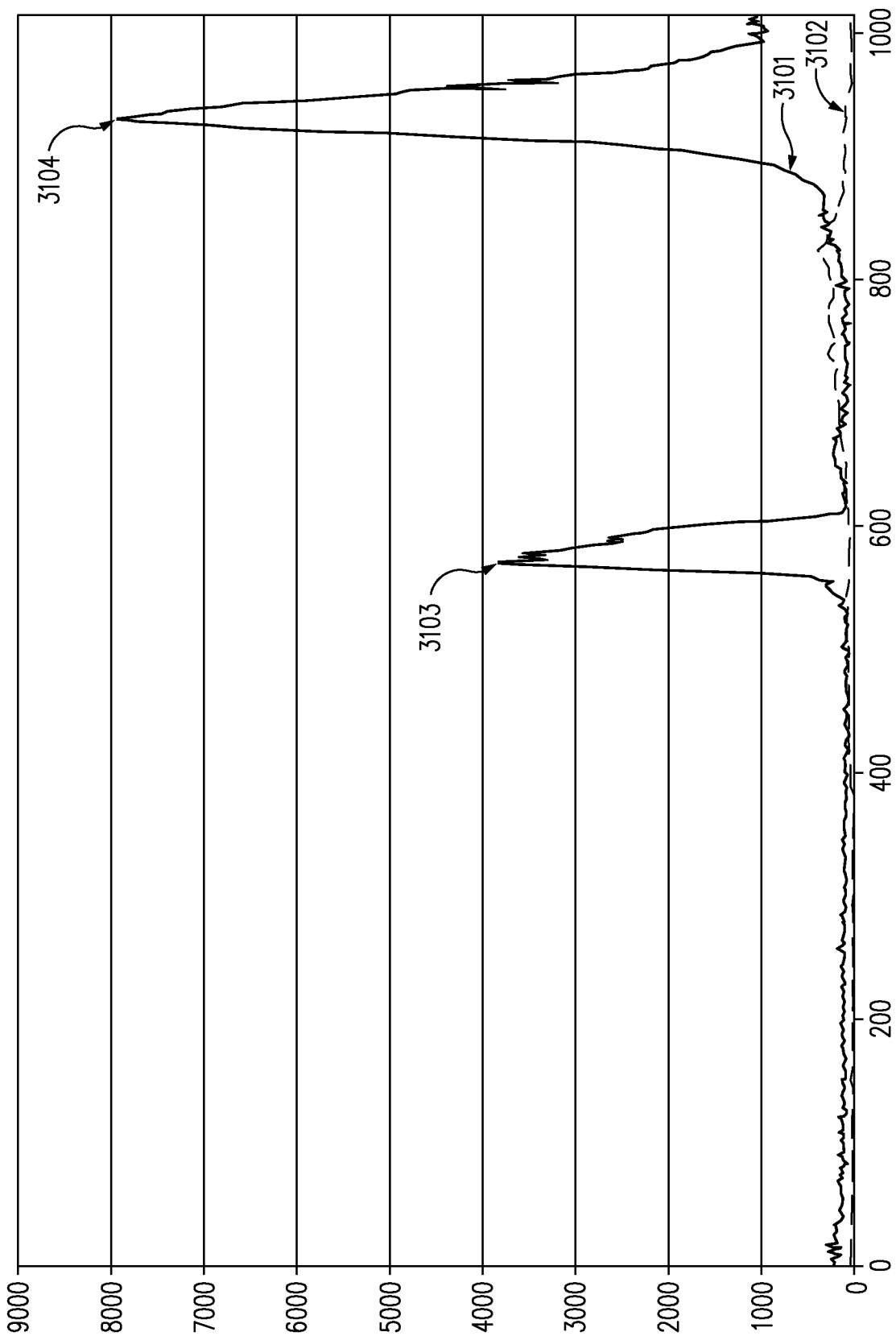

FIG. 31