

(No Model.)

J. ZUNDORFF.  
Parlor Rifle.

No. 237,357.

Patented Feb. 1, 1881.

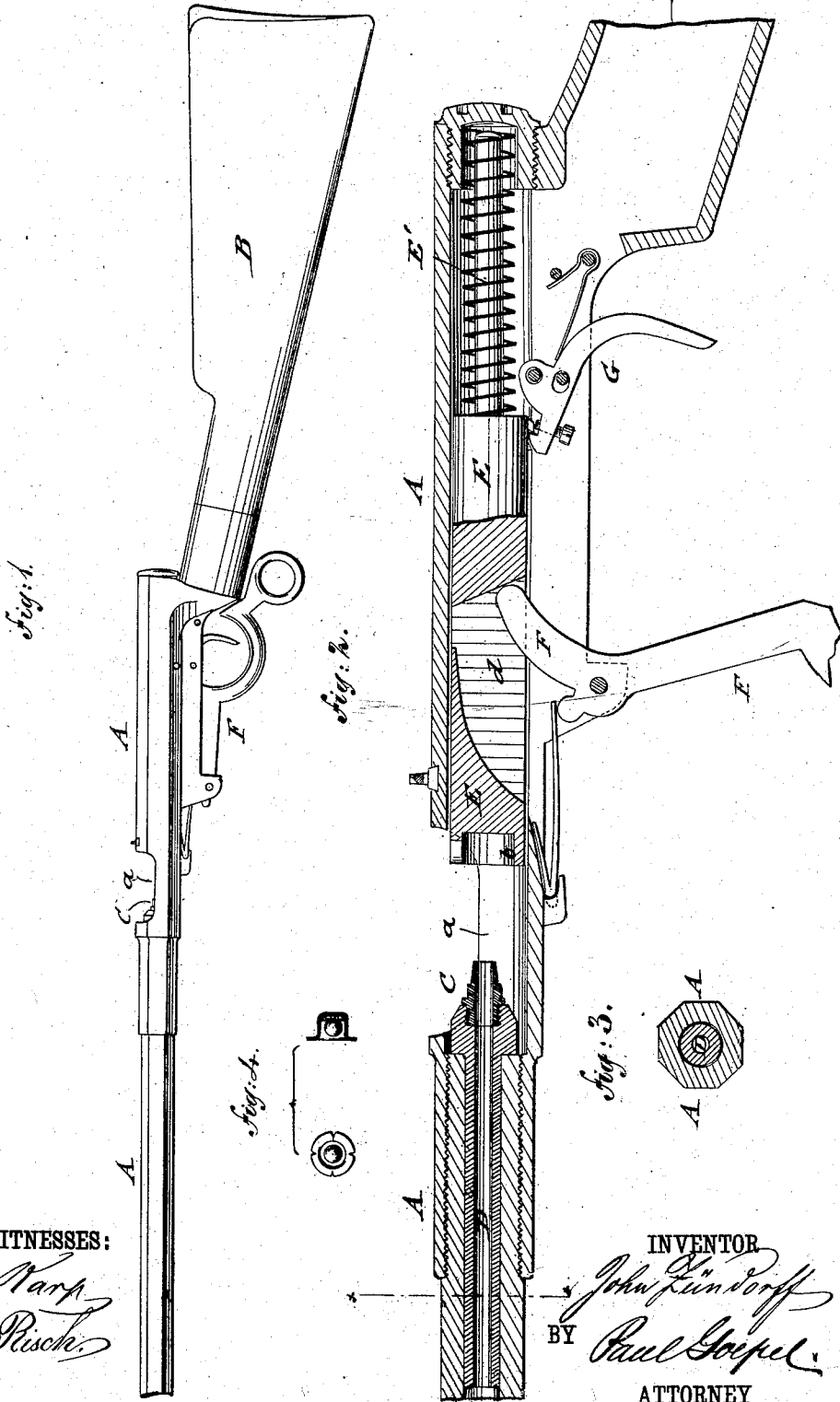

WITNESSES:  
*Carl Karp*  
*Otto Pische*

INVENTOR  
*John Zundorff*  
BY  
*Paul Goppel*  
ATTORNEY

# UNITED STATES PATENT OFFICE.

JOHN ZÜNDORFF, OF NEW YORK, N. Y.

## PARLOR-RIFLE.

SPECIFICATION forming part of Letters Patent No. 237,357, dated February 1, 1881.

Application filed May 6, 1880. (No model.)

To all whom it may concern:

Be it known that I, JOHN ZÜNDORFF, of the city, county, and State of New York, have invented certain new and useful Improvements in Parlor-Rifles, of which the following is a specification.

This invention relates to an improved parlor rifle or pistol which is loaded through the nipple and charged with a cheap and simple cartridge, by which the present rather expensive cartridges may be dispensed with.

The invention consists of a barrel made of two sections, the front section of which has an interior shell with a nipple of the same diameter and in line therewith. A cylindrical and spring-acted hammer is guided in the rear section of the barrel and set into cocked position by a fulcrumed lever and a trigger. The hammer is provided with an annular front guard-flange.

In the accompanying drawings, Figure 1 represents a side view of my improved parlor-rifle; Fig. 2, a vertical longitudinal section of the same on a larger scale; Fig. 3, a vertical transverse section through the barrel of the rifle on line *x x*, Fig. 2; and Fig. 4 is an end view and a section of the cartridge employed for the rifle.

Similar letters of reference indicate corresponding parts.

Referring to the drawings, A represents the barrel, and B the stock, of my improved parlor rifle or pistol. The barrel A is made of two parts or sections, between which a recess or opening, *a*, of sufficient length, is arranged to get easily at the nipple C, which is screwed centrally into the rear end of an interior shell or cylinder, D, of the front section of the barrel. The nipple and shell have an opening of equal diameter throughout, said opening corresponding to the size of the ball of the cartridge to be used.

In the rear section of the barrel A is arranged a solid cylindrical hammer, E, which is acted upon at its rear end by a strong spiral spring, E', the spring being placed around the stem of the hammer, between the shoulder of the same and a socket-shaped screw-cap of the rear section of the barrel. The hammer is provided at its front part with a guard-flange, *b*, which forms a kind of socket for the nipple and prevents the escape of any portion of the cartridge. A fulcrumed handle-lever, F, engages a recess, *d*, of the hammer E, and throws

the same back until retained by a trigger, G, which springs into a catch of the hammer. The trigger G is of any approved construction, and retains the hammer in cocked position, so as to admit it to be thrown by the spring on being released therefrom.

The cartridge consists of a common percussion-cap—such as used for regular United States fire-arms—and of a ball, which is retained at the interior of the cap by means of tallow or other suitable material. The cartridge is placed in position on the nipple, the pressure thereon forcing the ball into the same. When the hammer strikes the cap the force of the concussion throws the ball with considerable force through the nipple and shell. When the nipple becomes battered by use it can be readily replaced by a new one, so that the rifle is always in condition for use.

The cartridge employed is cheaper than those at present in use for parlor-rifles, but accomplishes in every respect the same results.

The hammer moves in line with the nipple in the rear section of the barrel, and is readily set by its lever, forming, in connection with the front barrel and nipple, a nipple-loading parlor-rifle of a simple and durable construction.

Having thus described my invention, I claim as new and desire to secure by Letters Patent—

1. In a parlor-rifle, the combination of the main barrel having an interior or supplemental barrel, the latter being provided with a nipple of equal bore with that of the interior barrel, with a sliding and spring-acted hammer having an annular front guard-flange, substantially as set forth.

2. In a parlor-rifle, the combination of the main barrel having an interior or supplemental barrel and a nipple of equal bore therewith with a cylindrical and spring-acted hammer having a recess and a projecting catch back of the same, and with a fulcrumed lever and spring-acted trigger, all substantially as specified.

In testimony that I claim the foregoing as my invention I have signed my name, in presence of two witnesses, this 20th day of April, 1880.

JOHN ZÜNDORFF.

Witnesses:  
PAUL GOEPEL,  
ADOLF DENGLER.