



(19) **United States**

(12) **Patent Application Publication**

**Park et al.**

(10) **Pub. No.: US 2005/000033 A1**

(43) **Pub. Date:**

**Jan. 6, 2005**

(54) **WASHING METHOD IN WASHING MACHINE INCLUDING SEMI-DRYING CYCLE AND CONTROL APPARATUS THEREFOR**

Aug. 25, 2003 (KR) ..... 2003-58752

**Publication Classification**

(51) **Int. Cl.<sup>7</sup>** ..... **D06F 33/00**

(52) **U.S. Cl.** ..... **8/159; 68/12.12**

(76) Inventors: **Seok Kyu Park**, Kyungsangnam-do (KR); **Young Soo Kim**, Kyungsangnam-do (KR)

(57) **ABSTRACT**

Correspondence Address:  
**BIRCH STEWART KOLASCH & BIRCH**  
**PO BOX 747**  
**FALLS CHURCH, VA 22040-0747 (US)**

A washing method in a washing machine including a semi-drying cycle, in which a spin-drying process and a disentangling process are repeatedly carried out several times in the semi-drying cycle at a speed lower than a spin-drying speed in a main spin-drying cycle. A washing mode involving the semi-drying cycle may be selectively inputted. In accordance with the washing method, wash water is heated in a rinsing cycle. In the semi-drying cycle, the spin-drying process is repeatedly executed at a spin-drying speed gradually increased as the semi-drying cycle progresses. In accordance with the washing method, it is possible to spin-dry the clothes to a water extraction rate of about 55 to 70%, while minimizing damage to the clothes and formation of wrinkles on the clothes.

(21) Appl. No.: **10/868,909**

(22) Filed: **Jun. 17, 2004**

(30) **Foreign Application Priority Data**

Jun. 20, 2003 (KR) ..... 2003-40190

Jun. 20, 2003 (KR) ..... 2003-40191

Jun. 20, 2003 (KR) ..... 2003-40192

Jul. 25, 2003 (KR) ..... 2003-51422

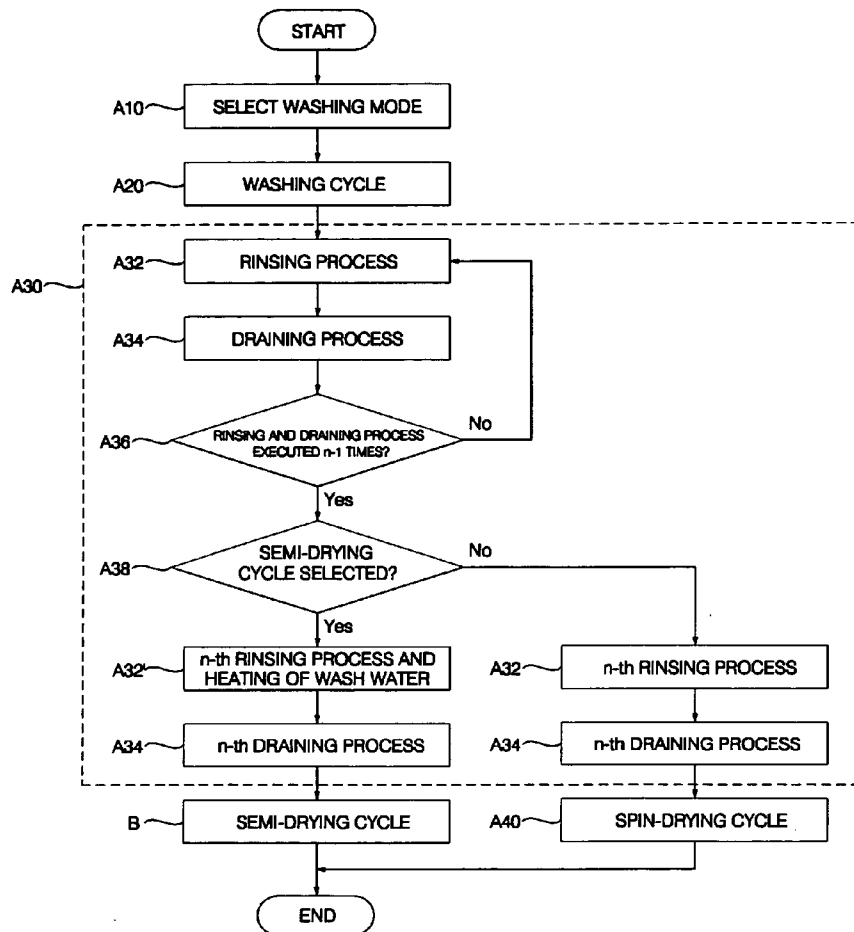

FIG. 1 (Prior Art)

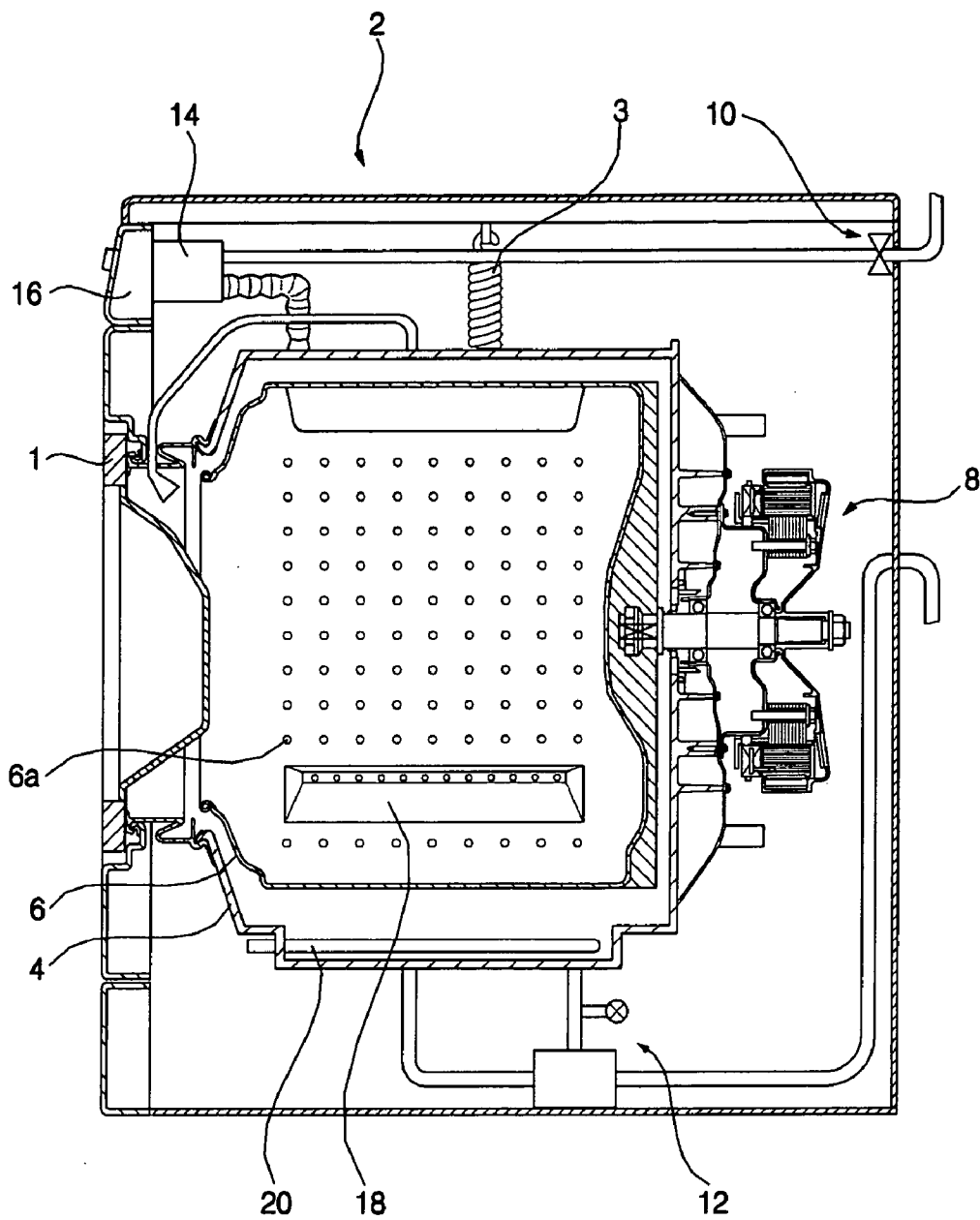

FIG. 2 (Prior Art)

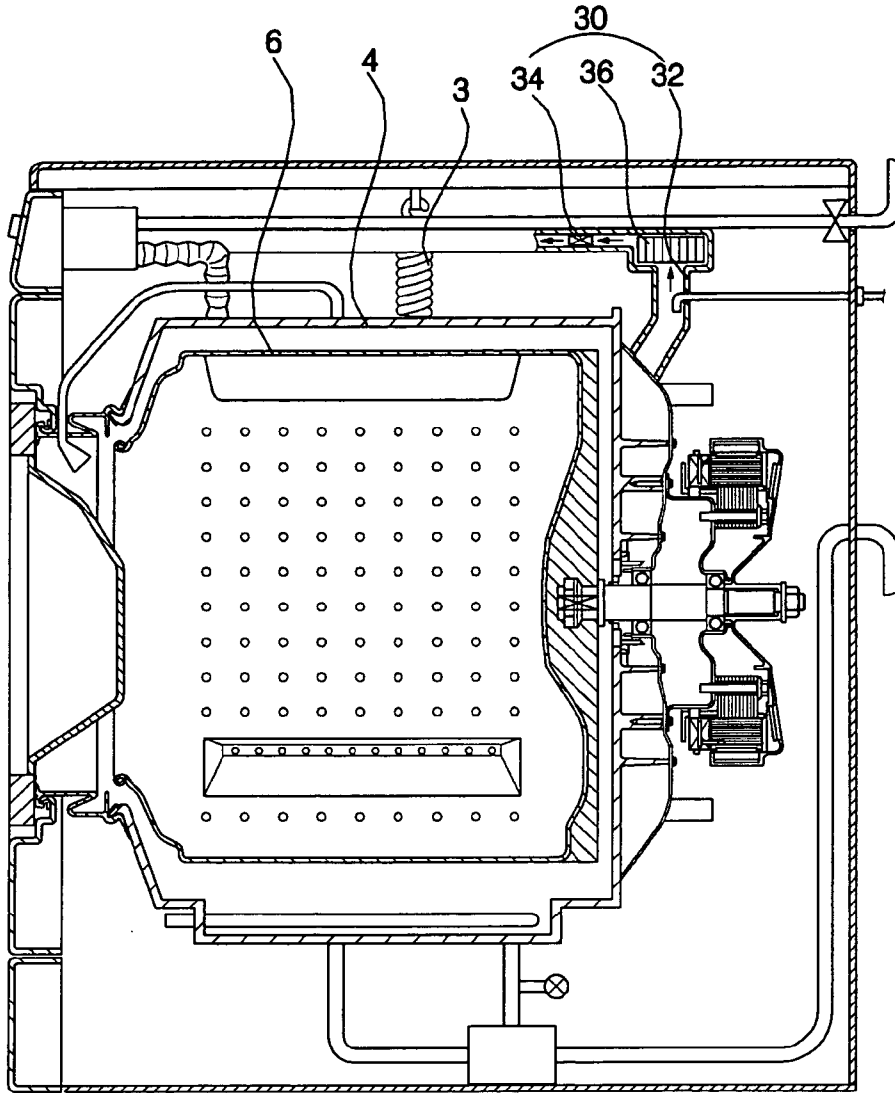

FIG. 3

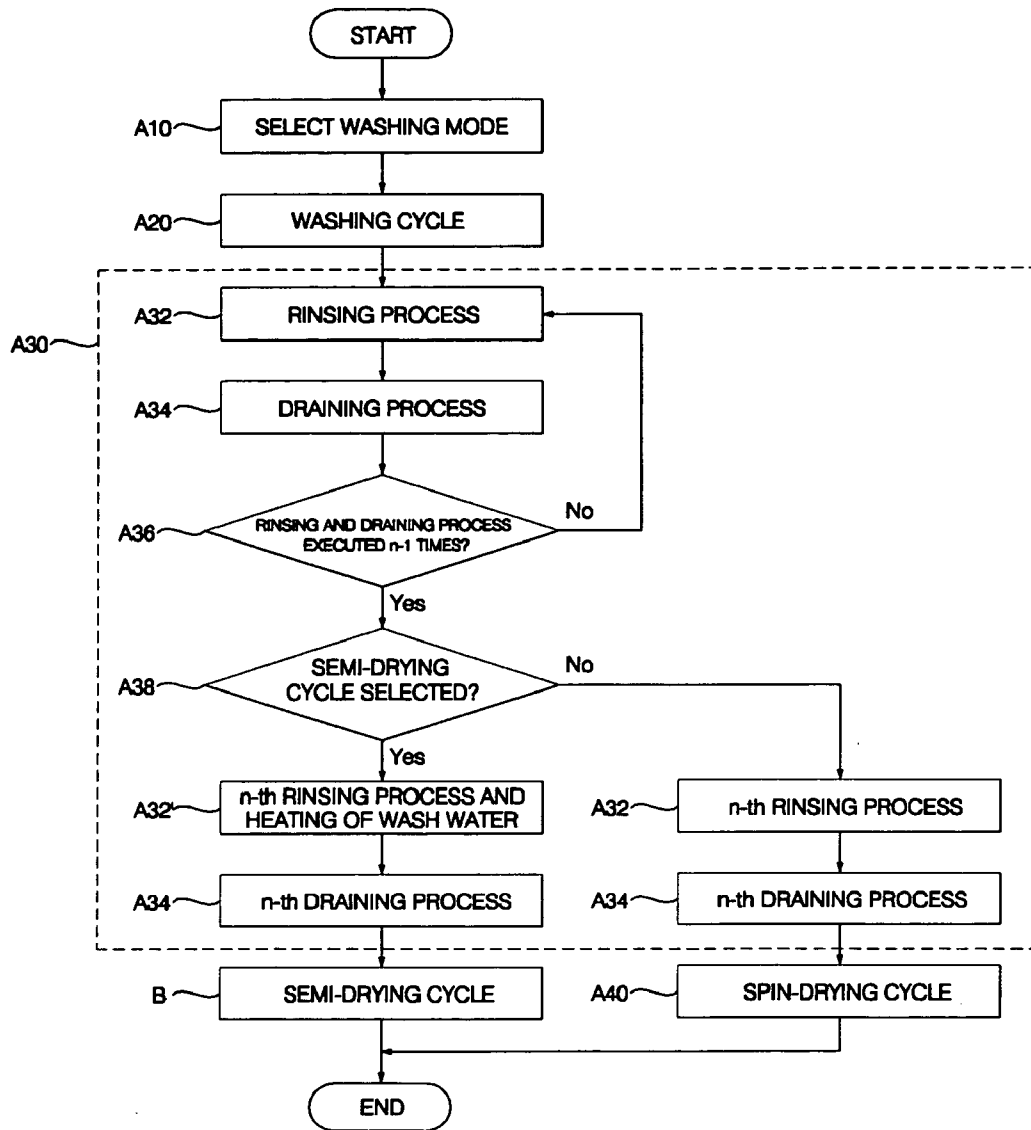
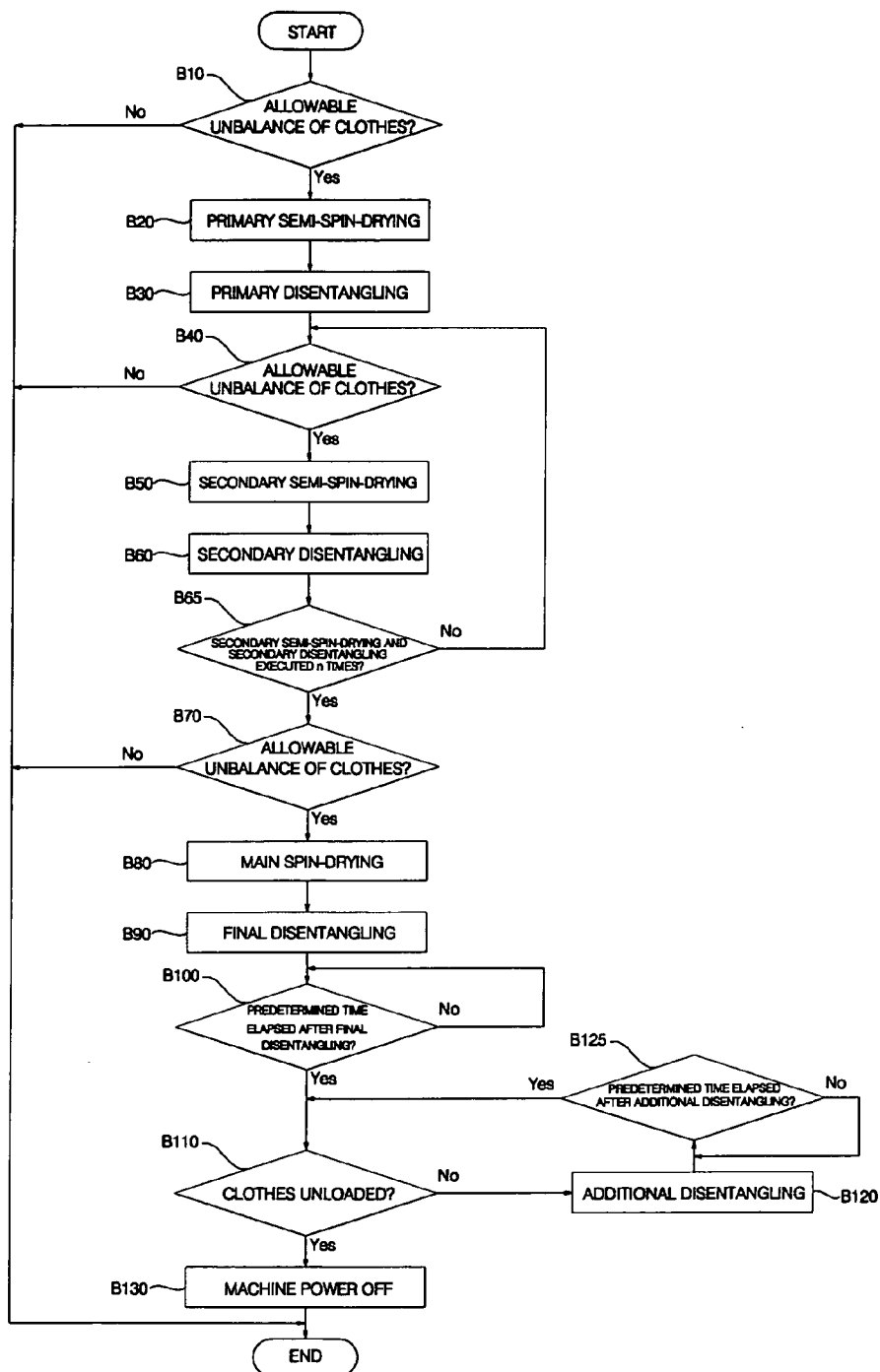

FIG. 4



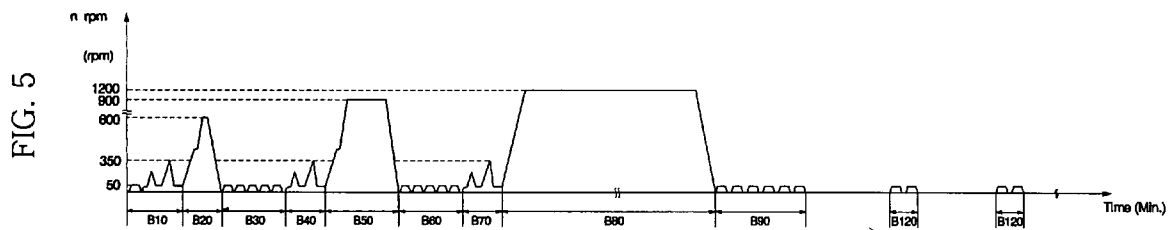

FIG. 6

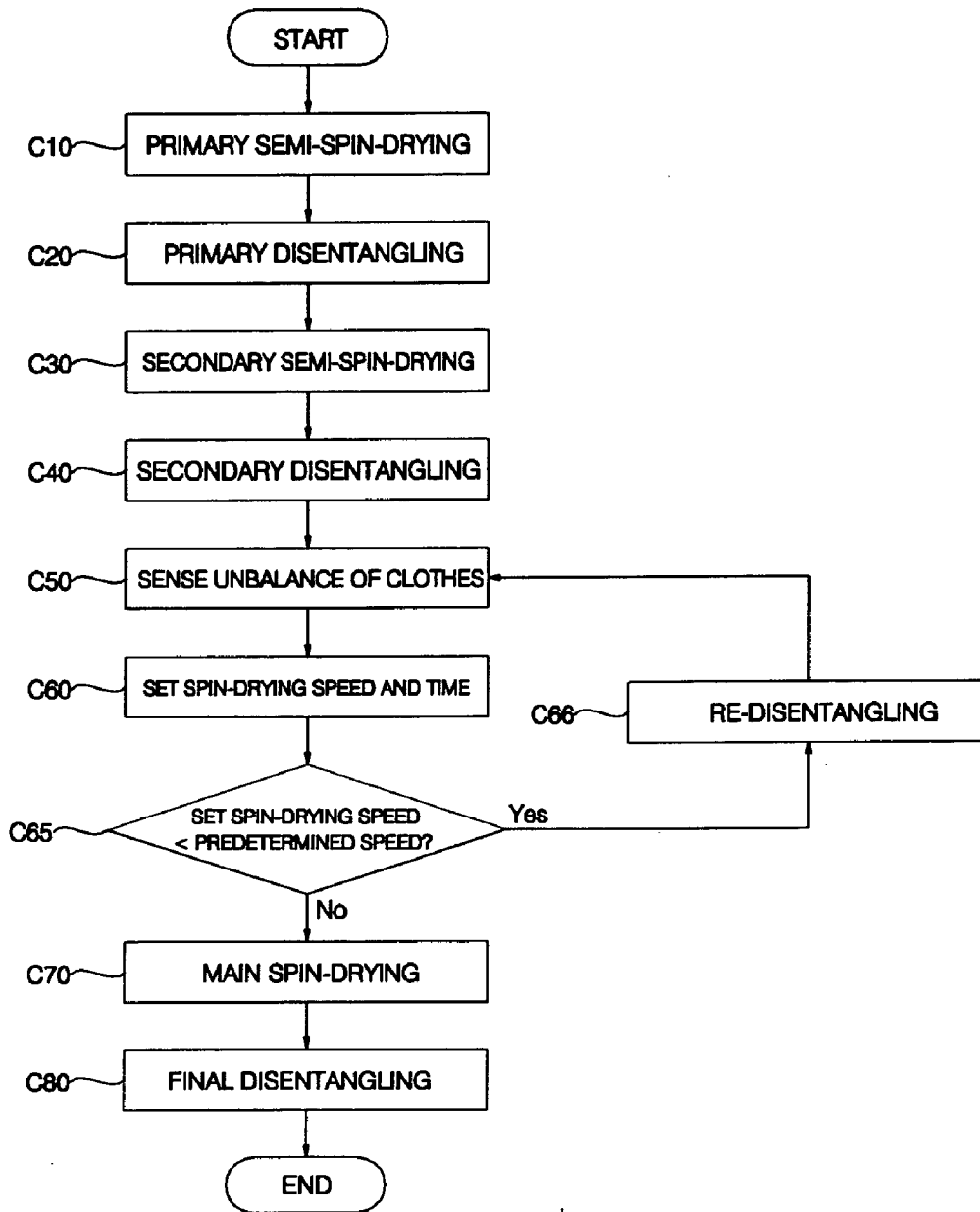

FIG. 7

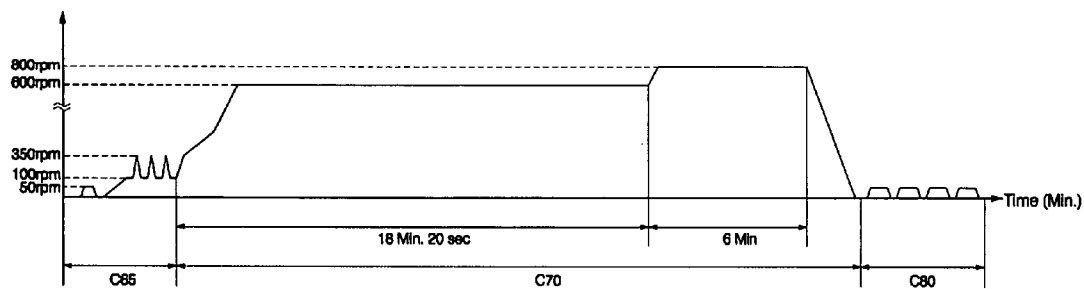
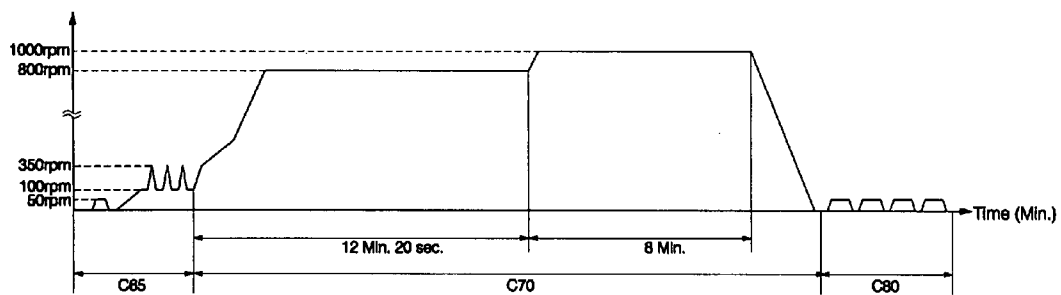



FIG. 8



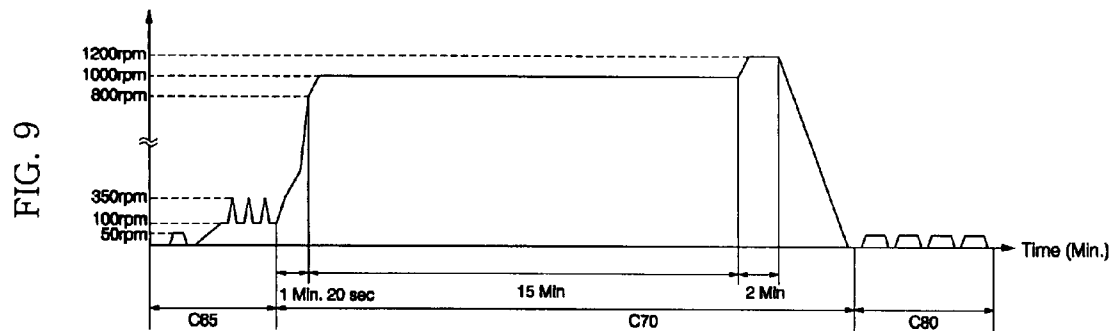

FIG. 10

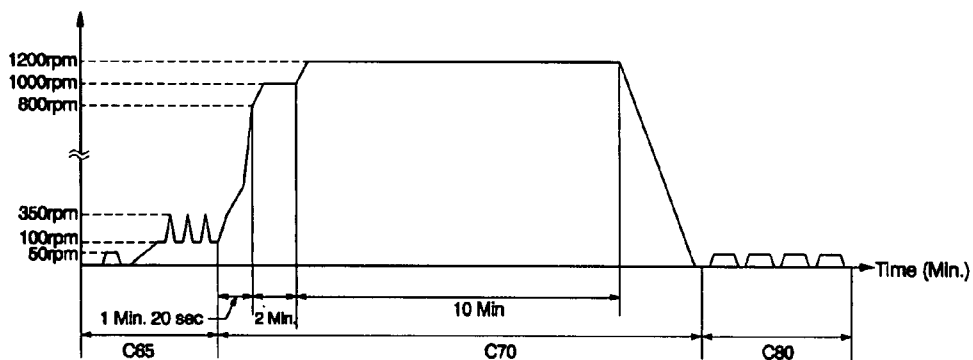

FIG. 11

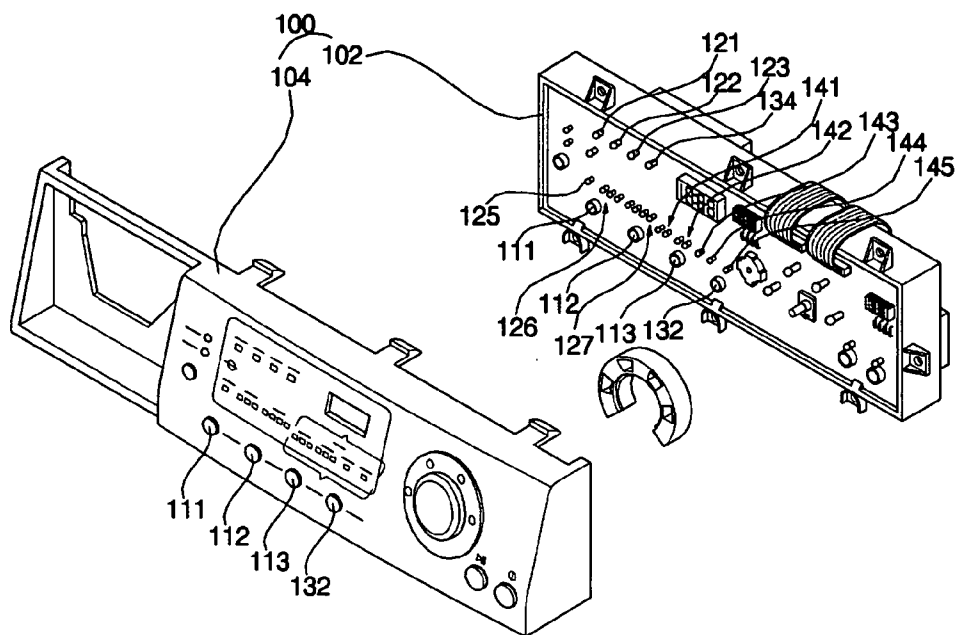

FIG. 12

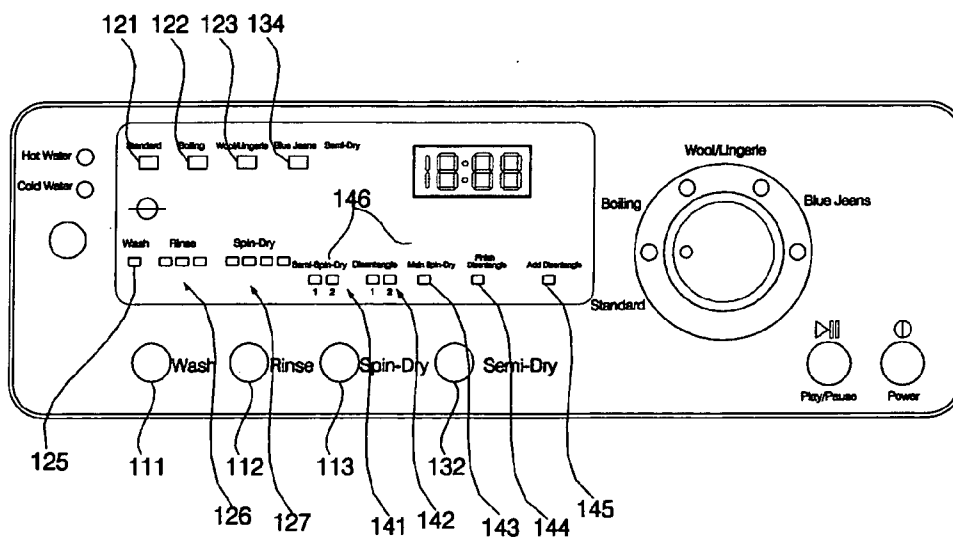
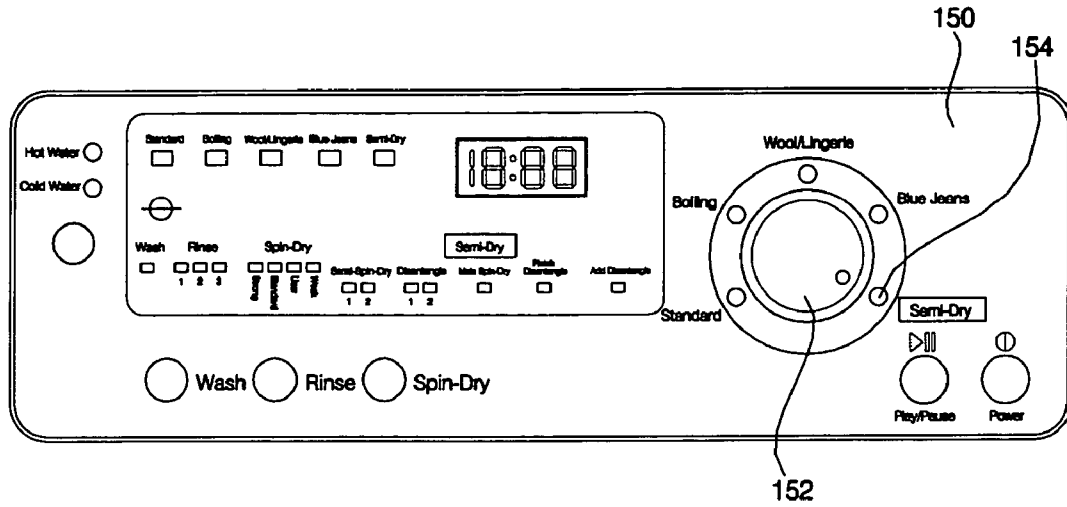

FIG. 13



**WASHING METHOD IN WASHING MACHINE  
INCLUDING SEMI-DRYING CYCLE AND  
CONTROL APPARATUS THEREFOR**

**BACKGROUND OF THE INVENTION**

**[0001]** 1. Field of the Invention

**[0002]** The present invention relates to a washing machine, and, more particularly, to a washing method in a washing machine including a semi-drying cycle, in which a spin-drying process and a disentangling process are repeatedly carried out several times for clothes, to spin-dry the clothes to a desired level, and a control apparatus for the washing method.

**[0003]** 2. Description of the Related Art

**[0004]** **FIG. 1** is a sectional view illustrating an inner configuration of a washing machine, in particular, a drum washing machine.

**[0005]** The drum washing machine shown in **FIG. 1** includes a cabinet **2** provided with a door **1** mounted to a front wall of the cabinet **2**, a tub **4** arranged in the interior of the cabinet **2** while being supported by dampers **3**, and a drum **6** rotatably mounted in the tub **4**, and provided with a plurality of water holes **6a**. The drum washing machine also includes a motor **8** arranged in rear of the tub **4**, and adapted to rotate the drum **6**, a water supply unit **10** adapted to supply wash water into the tub **4** and drum **6**, and a drainage unit **12** adapted to drain the wash water from the tub **4** and drum **6**.

**[0006]** The cabinet **2** is also provided with a detergent box **14** adapted to store detergent therein to supply the detergent, along with wash water flowing therethrough. A control panel **16** is also provided at the cabinet **2** to control operations of the washing machine. Lifters **18** are mounted to an inner peripheral surface of the drum **6**. The lifters **18** serve to raise clothes contained in the drum **6** to a desired level during rotation of the drum **6**. A heater **20** is installed in the interior of the tub **4** to heat the wash water supplied into the tub **4** and drum **6**.

**[0007]** In the washing machine having the above-described configuration, a washing method is carried out which involves a washing cycle for removing stains from clothes, a rinsing cycle for rinsing the clothes with clean wash water, and a spin-drying cycle for extracting moisture from the clothes. Generally, the washing, rinsing, and spin-drying cycles are executed in this order. Of course, these cycles may be selectively executed.

**[0008]** Now, the washing method will be described in the order of the washing, rinsing and spin-drying cycles.

**[0009]** When the washing machine begins to run under the condition in which clothes have been loaded in the drum **6**, wash water is supplied into the tub **4** and drum **6**, along with detergent. Subsequently, the drum **6** is rotated in accordance with a drive force from the motor **8**. As a result, the clothes are washed in accordance with a chemical action of the detergent, flows of the wash water, and frictional forces generated between the drum **6** and the clothes. The wash water contaminated during the washing cycle is then drained by the drainage unit **12**. Thus, the washing cycle is completed.

**[0010]** Next, wash water alone is again supplied into the tub **4** and drum **6** for the rinsing cycle. In a subsequent rotation of the drum **6**, the clothes are rinsed. The wash water contaminated during the rinsing cycle is then drained by the drainage unit **12**. Typically, this rinsing cycle is repeated several times.

**[0011]** After execution of the rinsing cycle several times, the drum **6** is rotated at a high speed of, for example, 1,000 to 3,000 RPM, for 3 to 5 minutes, to spin-dry the clothes using a centrifugal force generated during the rotation. Water extracted from the clothes during the spin-drying cycle is drained by the drainage unit **12**.

**[0012]** After completion of the spin-drying cycle, the user takes the clothes out of the drum **6** to naturally dry them, because the clothes are in a wet state.

**[0013]** **FIG. 2** is a sectional view illustrating an inner configuration of a washing machine provided with a dryer **30** adapted to completely dry clothes in a drum of the washing machine. The constituent elements of this washing machine, except for the dryer **30**, are identical or similar to those of **FIG. 1**. Accordingly, the following description will be given of only the dryer **30**, and the same constituent elements will be designated by like reference numerals, respectively.

**[0014]** The dryer **30** includes a drying duct **30** adapted to guide air such that the air circulates through the drum **6**, a drying heater **34** adapted to heat the air flowing through the drying duct **32**, and thus, to produce hot air, and a drying fan **36** adapted to forcibly feed the hot air from the drying duct **32** into the tub **4**.

**[0015]** In this washing machine, which is provided with the dryer **30**, a drying cycle is executed to dry clothes in the drum **6** within a short period of time, using the dryer **30**, after completion of the above-mentioned spin-drying cycle.

**[0016]** In accordance with the conventional washing method used in the above-mentioned drum washing machine, however, the drum rotates at high speed even from an initial stage in the spin-drying cycle to rapidly reach a predetermined spin-drying speed, and thus, to extract a large amount of water from the clothes within a short period of time in the spin-drying cycle. For this reason, the clothes may be caught by the water holes **6a** of the drum **6**. Furthermore, the spin-drying process is carried out in a state in which the clothes are entangled. As a result, it is necessary to disentangle the entangled clothes upon naturally drying the clothes after completion of the spin-drying cycle. Of course, a great deal of time and labor are required for the disentangling process. In addition, there is a problem in that it is necessary to perform a post-process such as ironing because the clothes are inevitably heavily wrinkled due to the high-speed spin-drying process.

**[0017]** Since the clothes still contains a large amount of moisture even after the spin-drying cycle, it is also necessary to dry the clothes for a prolonged period of time after taking the clothes out of the washing machine. For this reason, there may be a restriction in performing the drying process due to weather conditions and time. Although it is possible to reduce the time taken in the natural drying process by rotating the drum **6** for an increased time in the spin-drying cycle to obtain the water-extraction rate of the clothes, there may be a problem in that damage to the clothes increases correspondingly.

[0018] In the case of the drum washing machine provided with the dryer 30, as in FIG. 2, it is possible to conveniently dry clothes in the washing machine, using the dryer 30. In this case, however, there is an increase in costs caused by the provision of the dryer 30. Furthermore, the consumption of energy increases because about 2 or 3 hours are taken to completely dry clothes by means of the dryer 30. Since the drying of clothes is carried out in a closed space, using hot air, there may be a problem in that the clothes may give out a bad smell, and be easily damaged.

#### SUMMARY OF THE INVENTION

[0019] The present invention has been made in view of the above-mentioned problems involved with the related art, and it is an object of the present invention to provide a washing method in a washing machine including a semi-drying cycle, in which a spin-drying process and a disentangling process are repeatedly carried out several times in the semi-drying cycle at a speed lower than a spin-drying speed in a main spin-drying cycle, thereby being capable of spin-drying the clothes to a water extraction rate of about 55 to 70%, while minimizing damage to the clothes and formation of wrinkles on the clothes.

[0020] It is another object of the invention to provide a washing method in a washing machine including a semi-drying cycle, in which, where a rinsing cycle is carried out, using heated wash water, and a semi-drying cycle is carried out, following the rinsing cycle, under the condition in which heat is still present in the washing machine, thereby being capable of promoting water extraction and drying of the clothes during the semi-drying cycle, while minimizing formation of wrinkles on the clothes.

[0021] It is another object of the invention to provide a control apparatus for a washing machine including a semi-drying cycle, which is capable of selecting a desired cycle, for example, a washing cycle, a rinsing cycle, a spin-drying cycle, or the semi-drying cycle, which is adapted to accomplish the above-mentioned objects, and checking the progress of the semi-drying cycle.

[0022] In accordance with one aspect, the present invention relates to a semi-drying method in a washing machine comprising the step of: executing a multi-stage spin-drying process to extract water contained in clothes washed in the washing machine while gradually increasing a spin-drying speed of a drum containing the clothes such that a higher stage of the spin-drying process is executed at a higher spin-drying speed; and rotating the drum in a stirring fashion after completion of each stage of the multi-stage spin-drying process, to execute a disentangling process.

[0023] The drum may be rotated at a spin-drying speed at each stage of the multi-stage spin-drying process when the clothes are maintained within an allowable unbalance range prior to execution of the stage.

[0024] The drum may be rotated at a spin-drying speed at each stage of the multi-stage spin-drying process for a time set such that the rotating time at one stage is longer than the rotating time at the stage preceding said one stage.

[0025] In accordance with another aspect, the present invention provides a semi-drying method in a washing machine comprising: a primary semi-spin-drying step for rotating a drum at a predetermined spin-drying speed to spin

dry clothes contained in the drum by a centrifugal force generated during the rotation of the drum; a primary disentangling step for rotating the drum in a stirring fashion to disentangle the clothes, after completion of the primary semi-spin-drying step; a secondary semi-spin-drying step for rotating the drum at a spin-drying speed higher than at the primary semi-spin-drying step, after completion of the primary disentangling step; a secondary disentangling step for rotating the drum in a stirring fashion to disentangle the clothes, after completion of the secondary semi-spin-drying step; a main spin-drying step for rotating the drum at a high spin-drying speed to spin-dry the clothes at a water extraction rate higher than at the secondary semi-spin-drying step, after completion of the secondary disentangling step; and a final disentangling step for rotating the drum in a stirring fashion to disentangle the clothes, after completion of the main spin-drying step.

[0026] The clothes may be maintained within an allowable unbalance range prior to execution of each of the primary semi-spin-drying step, secondary semi-spin-drying step, and main spin-drying step, the drum is rotated at the spin-drying speed, which is predetermined for the associated spin-dry step.

[0027] Respective rotating times, for which the drum is rotated at the primary and secondary semi-spin-drying steps, may be set such that the rotating time at the secondary semi-spin-drying step is longer than the rotating time at the primary semi-spin-drying step.

[0028] The secondary semi-spin-drying step and the secondary disentangling step may be further repeatedly executed a plurality of times in an alternating fashion. Respective spin-drying speeds of the drum at the repeated secondary semi-spin-drying steps may be set such that the spin-drying speed at one semi-spin-drying step is higher than the spin-drying speed at the semi-spin-drying step preceding said one semi-spin-drying step.

[0029] Respective rotating times, for which the drum is rotated at the repeated secondary semi-spin-drying steps, may be set such that the rotating time at one secondary semi-spin-drying step is longer than the rotating time at the semi-spin-drying step preceding said one secondary semi-spin-drying step.

[0030] The spin-drying speed of the drum at the main spin-drying step may be set to be higher than the spin-drying speed of the drum at the secondary semi-spin-drying step.

[0031] The spin-drying speed of the drum at the main spin-drying step may be set, based on an unbalance of the clothes sensed after completion of the secondary disentangling step.

[0032] The rotating time, for which the drum is rotated at the main spin-drying step, may be set such that the rotating time is increased as the set spin-drying speed of the drum at the main spin-drying step decreases. The spin-drying speed of the drum at the main spin-drying step may be increased in a step-wise fashion from the set spin-drying speed of the drum, as the main spin-drying step progresses.

[0033] The semi-drying method may further comprise a re-disentangling step for rotating the drum in a stirring fashion when the spin-drying speed of the drum set for the

main spin-drying step is lower than a predetermined speed, prior to execution of the main spin-drying step.

[0034] The semi-drying method may further comprise an additional disentangling step for rotating the drum in a stirring fashion when the clothes have been maintained in the drum until a predetermined time elapses after completion of the final disentangling step.

[0035] The additional disentangling step may be repeatedly executed at intervals of a predetermined time until the clothes are taken out of the drum.

[0036] The additional disentangling step may comprise the steps of comparing a load generated during a rotation of the drum at the additional disentangling step, which is currently executed, with a predetermined load, and determining, based on the result of the comparison, whether or not the clothes have been taken out of the drum.

[0037] The additional disentangling step may further comprise the step of turning off the washing machine when it is determined that the clothes have been taken out of the drum.

[0038] In accordance with another aspect, the present invention provides a washing method in a washing machine comprising: a rinsing cycle for repeatedly executing, a plurality of times, a rinsing process adapted to supply wash water into a drum containing clothes, and then to rotate the drum to rinse the clothes, and a draining process adapted to drain the wash water, while heating the wash water supplied in at least a final one of the repeated rinsing processes; and a semi-drying cycle for executing a multi-stage spin-drying process in such a manner that the drum is rotated at spin-drying speeds set for respective stages of the multi-stage spin-drying process to spin-dry the clothes by a centrifugal force generated during the rotation of the drum, and rotating the drum in a stirring fashion to disentangle the clothes after completion of each stage of the multi-stage spin-drying process.

[0039] The washing method may further comprise a spin-drying cycle for rotating the drum at a high spin-drying speed for a time shorter than an execution time of the semi-drying cycle, to spin-dry the clothes by a centrifugal force generated during the rotation of the drum. The spin-drying cycle or the semi-drying cycle may be selectively executed.

[0040] The semi-drying cycle may comprise: a primary semi-spin-drying step for rotating the drum at a predetermined spin-drying speed; a primary disentangling step for rotating the drum in a stirring fashion to disentangle the clothes, after completion of the primary semi-spin-drying step; a secondary semi-spin-drying step for rotating the drum at a spin-drying speed higher than at the primary semi-spin-drying step, after completion of the primary disentangling step; a secondary disentangling step for rotating the drum in a stirring fashion to disentangle the clothes, after completion of the secondary semi-spin-drying step; a main spin-drying step for rotating the drum at a high spin-drying speed to spin-dry the clothes at a water extraction rate higher than at the secondary semi-spin-drying step, after completion of the secondary disentangling step; and a final disentangling step for rotating the drum in a stirring fashion to disentangle the clothes, after completion of the main spin-drying step.

[0041] The spin-drying speed of the drum at the main spin-drying step may be set to be higher than the spin-drying speed of the drum at the secondary semi-spin-drying step.

[0042] The spin-drying speed of the drum at the main spin-drying step may be set, based on an unbalance of the clothes sensed after completion of the secondary semi-spin-drying step.

[0043] The semi-drying method may further comprise an additional disentangling step for rotating the drum in a stirring fashion when the clothes have been maintained in the drum until a predetermined time elapses after completion of the semi-drying cycle.

[0044] In accordance with another aspect, the present invention provides a control apparatus for a washing machine comprising: an operating unit adapted to allow a user to input a washing mode, and to display the progress of a washing operation carried out in the washing machine; and a semi-dry input unit provided at the operating unit, and adapted to allow the user to input a semi-drying mode, in which a multi-stage spin-drying process is executed in such a manner that a drum is rotated at spin-drying speeds set for respective stages of the multi-stage spin-drying process to extract water from clothes contained in the drum, and the drum is rotated in a stirring fashion to disentangle the clothes after completion of each stage of the multi-stage spin-drying process.

[0045] The control apparatus may further comprise a semi-dry display unit provided at the operating unit, and adapted to display the progress of the semi-drying mode.

#### BRIEF DESCRIPTION OF THE DRAWINGS

[0046] The above objects, and other features and advantages of the present invention will become more apparent after reading the following detailed description when taken in conjunction with the drawings, in which:

[0047] FIG. 1 is a sectional view illustrating an inner configuration of a general drum washing machine;

[0048] FIG. 2 is a sectional view illustrating an inner configuration of a washing machine provided with a dryer;

[0049] FIG. 3 is a flow chart illustrating a washing method in a washing machine, which includes a semi-drying cycle according to a first embodiment of the present invention;

[0050] FIG. 4 is a flow chart illustrating the semi-drying cycle according to the first embodiment of the present invention;

[0051] FIG. 5 is a graph depicting a variation in motor RPM depending on lapse of time in the semi-drying cycle according to the first embodiment of the present invention;

[0052] FIG. 6 is a flow chart illustrating a semi-drying cycle according to a second embodiment of the present invention;

[0053] FIGS. 7 to 10 are graphs depicting variations in motor RPM depending on lapse of time under various conditions given in the semi-drying cycle according to the second embodiment of the present invention, respectively;

[0054] FIG. 11 is a perspective view illustrating a control apparatus for the washing machine according to an embodiment of the present invention;



[0055] FIG. 12 is a plan view of the control apparatus shown in FIG. 11;

[0056] FIG. 13 is a plan view illustrating a control apparatus for the washing machine according to another embodiment of the present invention.

#### DETAILED DESCRIPTION OF THE PREFERRED EMBODIMENTS

[0057] Reference will now be made in detail to the embodiments of the present invention, examples of which are illustrated in the accompanying drawings. The embodiments are described below to explain the present invention by referring to the figures.

[0058] FIG. 3 is a flow chart illustrating a washing method in a washing machine, which includes a semi-drying cycle according to a first embodiment of the present invention.

[0059] This washing method will now be described in detail with reference to FIG. 3.

[0060] When a desired washing mode is selected through a control apparatus, which is shown in FIGS. 11 and 12 or FIG. 13, and adapted to allow the user to select a desired washing mode, and to display the progress of the selected washing mode (A10), a washing cycle A20 is first executed to remove stains from clothes, and a rinsing cycle A30 is subsequently executed to rinse the clothes with clean water. After completion of the rinsing cycle A30, a spin-drying cycle A40 adapted to rotate a drum at high speed for a relatively short period of time or a semi-drying cycle B according to the present invention is selectively executed to spin-dry the clothes, using a centrifugal force generated during the rotation of the drum.

[0061] Where the user selects, at step A10, a washing mode involving the spin-drying cycle A40, a washing operation is carried out in the order of the washing cycle A20, rinsing cycle A30, and spin-drying cycle A40, as in a typical washing mode.

[0062] In the rinsing cycle A30, a rinsing process A32 for rinsing clothes while rotating the drum in a state in which wash water has been supplied, and a draining process A34 are alternately and repeatedly carried out n times. In the rinsing process A32, the supplied wash water may be heated.

[0063] Typically, the spin-drying cycle A40 may be executed at a high spin-drying speed for a short period of time by driving a motor, which is adapted to rotate the drum, at a speed of 1,000 to 3,000 RPM for 3 to 5 minutes, in order to extract water from the clothes at a water extraction rate of about 50%. In this case, since the motor must be driven at high speed even from an initial stage of the spin-drying cycle, the clothes are spin-dried in a state of being caught by water holes formed through the wall of the drum by virtue of the centrifugal force. For this reason, there are problems in that a relatively low water extraction rate is obtained, and the clothes may be entangled or severely wrinkled.

[0064] On the other hand, where the user selects, at step A10, a washing mode involving the semi-drying cycle, a washing operation is carried out in the order of the washing cycle A20, rinsing cycle A30, and semi-drying cycle B.

[0065] In the rinsing cycle A30 of this washing mode, the above-described rinsing process A32 and draining process

A34 are alternately and repeatedly carried out predetermined times. In this case, however, at least the last one of the repeated rinsing processes, A32', is carried out under the condition in which wash water supplied into the drum has been heated to about 40° C. by a heater.

[0066] As heated wash water is used in at least the last rinsing process A32', it is possible to more effectively remove detergent and foreign matter remaining in the clothes, and thus, to achieve an improvement in rinsing performance. Furthermore, heat is still present in the washing machine after completion of the rinsing cycle A30. Accordingly, the heat can promote water extraction and drying of the clothes during the semi-drying cycle B. The heat also provides a steam ironing effect, so that it is possible to reduce formation of wrinkles on the clothes. Also, the heat still remains in the clothes when the clothes are taken out of the washing machine. Accordingly, the user may have a feeling of satisfaction that the clothes have been sufficiently dried. Thus, an improvement in impression quality is obtained. In addition, an enhancement in water extraction rate is achieved because moisture remaining in the clothes condenses by virtue of a difference between the temperature of the clothes and the ambient temperature.

[0067] FIG. 4 is a flow chart illustrating the semi-drying cycle according to the first embodiment of the present invention. FIG. 5 is a graph depicting a variation in the RPM of the motor depending on lapse of time in the semi-drying cycle according to the first embodiment of the present invention.

[0068] The semi-drying cycle B described above will be described in detail with reference to FIGS. 4 and 5. The drum may rotate at a speed different from the RPM of the motor in the case in which it is indirectly connected to the motor via a belt and pulleys. Even in the case in which the drum is directly connected to the motor, it may rotate at a speed different from the RPM of the motor due to a load, etc. However, the rotating speed of the drum is typically equal or proportional to the RPM of the motor. Accordingly, the following description will be given on the assumption that the rotating speed of the drum is equal to the RPM of the motor.

[0069] When severe unbalance of clothes occurs during rotation of the drum, severe vibrations may occur in the drum, and the clothes may be easily entangled. Accordingly, when the semi-drying cycle according to the present invention begins, a primary unbalance sensing step B10 is executed to sense an unbalance of the clothes.

[0070] At the primary unbalance sensing step B10, the motor is driven, for example, at 350 RPM for one minute, to detect a variation in the load of the motor during one revolution of the drum. The detected load variation of the motor is compared with a predetermined value, that is, a maximum allowable clothes unbalance.

[0071] When it is determined at the primary unbalance sensing step B10 that the sensed unbalance of the clothes is more than the allowable clothes unbalance, the drum may be rotated in a stirring fashion to execute disentangling of the clothes. Otherwise, the semi-drying cycle is stopped. An alarm is raised, or an error message is displayed to give the user a warning about the error.

[0072] On the other hand, when it is determined at the primary unbalance sensing step B10 that the sensed clothes

unbalance is not more than the allowable clothes unbalance, a primary semi-spin-drying step **B20** is executed to rotate the drum at a predetermined spin-dry speed, thereby spin-drying the clothes by a centrifugal force generated during the rotation of the drum.

[0073] Preferably, the spin-dry speed of the drum is set to correspond to a middle speed, in order to minimize a phenomenon that the clothes are caught by the water holes provided at the wall of the drum during the rotation of the drum. For the same purpose, the spin-dry time of the drum may also be set to be relatively short. For example, the motor may be driven at 600 RPM for about 30 seconds.

[0074] After completion of the primary semi-spin-drying step **B20**, a primary disentangling step **B30** is executed to rotate the drum in a stirring fashion at a relatively low speed such that the entangled clothes are disentangled. In accordance with such a rotation of the drum, the clothes entangled at the primary semi-spin-drying step **B20** are disentangled while being separated from the wall of the drum.

[0075] The primary disentangling step **B30** is carried out as the motor is repeatedly turned on and off in accordance with a predetermined duty value, thereby causing the drum to be alternately rotated in forward and reverse directions. Accordingly, the motor is rotated in a stirring fashion. The duty value of the motor may be set to  $\frac{1}{10}$ . Also, the motor may be driven at 50 RPM for 1 minute 30 seconds to 2 minute 30 seconds.

[0076] For reference, it is preferable that the primary disentangling step **B30** be executed after the motor stops a surplus rotation thereof following the turning-off thereof made at the primary semi-spin-drying step **B20**.

[0077] After completion of the primary disentangling step **B30**, a secondary unbalance sensing step **B40** is executed in the same manner as the primary unbalance sensing step **B10**.

[0078] When it is determined at the secondary unbalance sensing step **B40** that the sensed clothes unbalance is not more than the allowable clothes unbalance, a secondary semi-spin-drying step **B50** is executed to rotate the drum at a speed higher than the speed at the primary spin-drying step **B20**, thereby spin-drying the clothes by a higher centrifugal force generated during the rotation of the drum.

[0079] Since the clothes have been lightened in accordance with the semi-spin-drying thereof at the primary semi-spin-drying step **B20**, the spin-drying speed at the secondary semi-spin-drying step **B50** is set to be higher than the spin-drying speed at the primary semi-spin-drying step **B20**. Accordingly, although the secondary semi-spin-drying step **B50** is executed at an increased spin-drying speed, it is possible to minimize the phenomenon that the clothes are caught by the water holes of the drum. Preferably, the rotating time of the drum at the secondary semi-spin-drying step **B50** is set to be relatively longer than that at the primary semi-spin-drying step **B20**. For example, the motor is driven at 900 RPM for 3 minutes at the secondary spin-drying step **B50**.

[0080] After completion of the secondary semi-spin-drying step **B50**, a secondary disentangling step **B60** is executed in the same manner as the primary disentangling step **B30**.

[0081] The secondary semi-spin-drying step **B50** and secondary disentangling step **B60** may be alternately and

repeatedly executed  $n$  times (**B65**). Since the water extraction rate of the clothes is gradually increased as the number of times, for which the secondary semi-spin-drying step **B50** is executed, increases, it is desirable to set the spin-drying speed of the drum at the secondary semi-spin-drying step **B50** in such a manner that the spin-drying speed is gradually increased as the secondary semi-spin-drying step **B50** progresses. That is, it is desirable to set the spin-drying speed of the drum at the secondary semi-spin-drying step **B50** in such a manner that the spin-drying speed at the current stage of the secondary semi-spin-drying step **B50** is higher than the spin-drying speed at the stage just preceding the current stage.

[0082] Although the clothes are spin-dried in the primary and secondary semi-spin-drying steps **B20** and **B50** at a water extraction rate gradually increased as the spin-drying speed of the drum is increased in a stepwise fashion, the semi-spin-drying steps **B20** and **B50** may be considered as a primary spin-drying step. Since each of the primary and secondary disentangling steps **B30** and **B60** is executed between adjacent stages of the associated semi-spin-drying step **B20** or **B50** to disentangle the clothes, it is possible to minimize damage to the clothes or generation of wrinkles on the clothes while preventing the drum from vibrating severely.

[0083] After completion of the secondary disentangling step **B60**, a third unbalance sensing step **B70** is executed in the same manner as the primary and secondary unbalance sensing steps **B10** and **B40**. When it is determined at the third unbalance sensing step **B70** that the sensed clothes unbalance is not more than the allowable clothes unbalance, a main spin-drying step **B80** is executed to rotate the drum at a higher speed for a time longer than the rotating times at the primary and secondary spin-drying steps **B20** and **B50**, so as to spin-dry the clothes at a higher water extraction rate by a higher centrifugal force.

[0084] Since the clothes have been primarily spin-dried through the primary and secondary semi-spin-drying steps **B20** and **B50**, it is possible to minimize the phenomenon that the clothes are caught by the water holes of the drum, even through the drum rotates at a higher speed for an increased time. The motor may be driven at 1,200 RPM for 13 minutes at the main spin-drying step **B80**.

[0085] After completion of the main spin-drying step **B80**, a final disentangling step **B90** is executed to rotate the drum in a stirring fashion, and thus, to disentangle the clothes entangled at the main disentangling step **B80** while separating the clothes from the wall of the drum.

[0086] Although the final disentangling step **B90** is executed in the same manner as the primary and secondary disentangling steps **B30** and **B60**, the motor is driven at the final disentangling step **B90** for a time longer than those at the primary and secondary disentangling steps **B30** and **B60**. For example, the final disentangling step **B90** is executed for 3 minutes.

[0087] In accordance with completion of the final disentangling step **B90**, the semi-drying cycle according to the present invention is completed.

[0088] Now, the operation and effect of the semi-drying cycle according to the present invention will be described.

[0089] The clothes are spin-dried at the main spin-drying step B80 as the drum rotates at high speed for a long time, after being primarily spin-dried through the primary and secondary semi-spin-drying steps B20 and B50. Accordingly, it is possible to spin-dry the clothes at a water extraction rate of 55 to 70% higher than that of a general spin-drying cycle, without causing damage to the clothes.

[0090] Accordingly, the clothes spin-dried through the semi-drying cycle according to the present invention can be naturally dried indoors or outdoors within a short period of time. After being simply subjected to a post-processing such as ironing, the clothes can also be worn by the user.

[0091] As described above, the spin-drying speed of the drum is set for each stage of each spin-drying process in order to minimize the phenomenon that the clothes are caught by the water holes of the drum during each spin-drying step. Also, disentangling of the clothes is carried out between adjacent stages of each spin-drying process. As a result, there is no damage to the clothes. Also, the clothes can be uniformly disentangled. Accordingly, it is convenient to take the clothes out of the drum, and to dry the clothes. Since there are few wrinkles on the clothes, a post-processing such as ironing, may be eliminated.

[0092] Since the execution time of the semi-drying cycle according to the present invention is about 30 minutes, it is possible to reduce the consumption of electric power, as compared to the case in which clothes are dried, using a dryer. Also, there is no phenomenon that the clothes give out a bad smell. In addition, there is an advantage in that the total washing time taken to wash and completely dry the clothes is shorter than the case using a general spin-drying cycle alone or along with a drying cycle to be executed by a dryer.

[0093] Meanwhile, as shown in FIGS. 4 and 5, an additional disentangling process (including steps B100 to B130) may be executed to disentangle the clothes where the clothes are maintained in the drum for a prolonged period of time after completion of the semi-drying cycle, by rotating the drum in a stirring fashion.

[0094] The additional disentangling process includes a clothes unloading checking step B110 for checking whether or not the clothes are maintained in an unloaded state, after a predetermined time has elapsed from the completion of the final disentangling process B90, and an additional disentangling step B120 for rotating the drum in a stirring fashion when the clothes are maintained in an unloaded state.

[0095] At the clothes unloading checking step B110, it is determined whether or not the clothes are maintained in an unloaded state, by detecting a load generated at the motor while rotating the drum for a short time after the predetermined time has elapsed from the completion of the final disentangling process B90, and comparing the detected load with a predetermined load. The predetermined load corresponds to a load generated at the motor when the drum rotates under the same condition as in the clothes unloading checking step B110, but in a state in which there are no clothes in the drum. When it is checked through the clothes unloading checking step B110 that the clothes are maintained in an unloaded state, the washing machine is turned off (B130).

[0096] The additional disentangling step B120 is executed by repeatedly turning on and off at 50 RPM for 15 to 25 seconds in accordance with a predetermined duty value.

[0097] Preferably, the additional disentangling process including steps B100 to B130 is executed at intervals of a predetermined time, for example, 8 to 12 minutes, until the clothes are unloaded.

[0098] FIG. 6 is a flow chart illustrating a semi-drying cycle according to a second embodiment of the present invention. FIGS. 7 to 10 are graphs depicting variations in the RPM of the motor depending on lapse of time under various conditions given in the semi-drying cycle according to the second embodiment of the present invention, respectively.

[0099] In the semi-drying cycle according to the second embodiment of the present invention, a primary semi-spin-drying step C10, a primary disentangling step C20, a second semi-spin-drying step C30, and a second disentangling step C40 are first carried out in this order and in the same manner as the semi-drying cycle according to the first embodiment of the present invention.

[0100] After completion of the secondary disentangling step C40, an unbalance sensing step C50 is executed to sense an unbalance of the clothes in the same manner as the unbalance sensing step according to the first embodiment of the present invention. Based on the sensed unbalance, the spin-drying speed of the drum is set (S60)

[0101] The spin-drying speed of the drum is determined such that it is lower at a lower unbalance of the clothes because the lower unbalance means that the clothes are in a more uniformly stacked state. Accordingly, the RPM of the motor may be set to 400 RPM, 600 RPM, 800 RPM, 1,000 RPM, or 1,200 RPM in accordance with the unbalance of the clothes.

[0102] Where the sensed RPM of the motor is lower than a predetermined RPM, for example, 400 RPM in this case, (C65), it means that the unbalance of the clothes is so high that it is difficult for the drum to rotate normally. In this state, accordingly, it is preferable that the motor be driven at 350 RPM in a stirring fashion for a short time, in order to execute a re-disentangling step C66. After completion of the re-disentangling step C66, the unbalance of the clothes is again sensed, and the RPM of the motor is again set, based on the sensed unbalance.

[0103] At step C60, the rotating time of the drum is also set. When the set spin-drying speed of the drum is lower, a lower water extraction rate of the clothes is obtained. Accordingly, the rotating time of the drum is set such that it is longer, at a lower spin-drying speed, than at a higher spin-drying speed.

[0104] When the rotating time of the drum is increased, it is possible to increase the water extraction rate of the clothes. In such a manner, it is possible to spin-dry the clothes to obtain a desired water extraction rate. In this case, however, the spin-drying time may be excessively lengthened. Accordingly, it is desirable to set the spin-drying speed of the drum in a subsequent main spin-drying step C70 in such a manner that the spin-drying speed is increased in a step-wise fashion as the spin-drying process progresses, in order to minimize the spin-drying time.

[0105] After setting the spin-drying speed and time of the drum, the main spin-drying step C70 is executed. At the main spin-drying step C70, the drum is rotated at the set

spin-drying speed for the predetermined time, which is relatively long, in order to spin-dry the clothes at an water extraction rate higher than that of the secondary semi-spin-drying step C30.

[0106] For example, where the rotating speed of the motor is set to 600 RPM, based on the sensed unbalance of the clothes, it is desirable that the motor is driven at 600 RPM for 18 minutes 20 seconds, and then at 800 RPM for 6 minutes, as shown in FIG. 7.

[0107] Where the rotating speed of the motor is set to 800 RPM, based on the sensed unbalance of the clothes, it is desirable that the motor is driven at 800 RPM for 12 minutes 20 seconds, and then at 1,000 RPM for 8 minutes, as shown in FIG. 8.

[0108] When the rotating speed of the motor is set to 1,000 RPM, based on the sensed unbalance of the clothes, it is desirable that the motor is driven at 800 RPM for 1 minutes 20 seconds, then at 1,000 RPM for 15 minutes, and finally at 1,200 RPM for 2 minutes, as shown in FIG. 9.

[0109] Also, when the rotating speed of the motor is set to 1,200 RPM, based on the sensed unbalance of the clothes, it is desirable that the motor is driven at 800 RPM for 1 minutes 20 seconds, then at 1,000 RPM for 2 minutes, and finally at 1,200 RPM for 10 minutes, as shown in FIG. 10.

[0110] After completion of the main spin-drying step C70 executed in the above described manner, a final disentangling step C80 is executed in the same manner as in the first embodiment of the present invention.

[0111] Subsequently, an additional disentangling step may be executed, as in the first embodiment of the present invention.

[0112] In accordance with the semi-spin-drying cycle according to the second embodiment of the present invention, it is possible to prevent generation of excessive vibrations in the drum or disentangling of clothes caused by unbalance of the clothes, while obtaining the effects expected in the semi-spin-drying cycle according to the first embodiment of the present invention, because the spin-drying speed at the main spin-drying step C70 is set based on the unbalance of the clothes.

[0113] Hereinafter, a control apparatus for a washing machine according to the present invention will be described. The control apparatus is adapted to implement the semi-drying cycle according to the present invention. In the following description, no description will be given of the semi-drying cycle because the semi-drying cycle has been described in detail.

[0114] FIG. 11 is a perspective view illustrating a control apparatus for the washing machine according to an embodiment of the present invention. FIG. 12 is a plan view of the control apparatus shown in FIG. 11.

[0115] As shown in FIG. 11, the control apparatus includes an operating unit 100 adapted to allow the user to input a desired washing mode therethrough, and to display the progress of the selected washing mode, a semi-dry input unit provided at the operating unit 100, and adapted to allow the user to input a semi-drying mode corresponding to the semi-drying cycle according to the present invention therethrough, and a semi-dry display unit adapted to display the progress of the selected semi-drying mode.

[0116] The operating panel 100 mainly includes a printed circuit board 102 electrically connected to a microcomputer

for controlling operations of the washing machine, and carrying thereon electronic elements adapted to input a washing mode and display the progress of the washing mode, and a control panel 104 forming the appearance of the printed circuit board 102, while being provided with symbols or letters representing respective functions of the electronic elements.

[0117] The electronic elements include a wash switch 111, a rinse switch 112, and a spin-dry switch 113 arranged in a horizontally aligned state at a lower left portion of the control panel 104, and adapted to allow the user to select the associated modes, that is, the washing, rinsing, and spin-drying cycles, respectively. The electronic elements also include a wash diode 121, a rinse diode 122, and a spin-dry diode 123 arranged in a horizontally aligned state at an upper left portion of the control panel 104, and adapted to emit light when the associated cycles, that is, the washing, rinsing, and spin-drying cycles, are selected, respectively.

[0118] The semi-dry input unit includes a touch type semi-dry switch 132 arranged on the right of the spin-dry switch 113, and a semi-dry diode 134 arranged on the right of the spin-dry diode 123, and adapted to emit light when the semi-dry switch 132 is selected.

[0119] The electronic elements further include a wash progress diode 125, a rinse progress diode 126, and a spin-dry progress diode 127 arranged at a left middle portion of the control panel 104, and adapted to display the progress of the associated cycles, that is, the washing, rinsing, and spin-drying cycles, respectively. The semi-dry display unit includes a semi-spin-dry progress diode 141, a disentangle progress diode 142, a main spin-dry progress diode 143, and a final disentangle progress diode 144 arranged in a horizontally-aligned state on the right of the spin-dry progress diode 127, and adapted to emit light when the associated processing steps are sequentially executed in the semi-drying cycle, respectively. The semi-dry display unit may further include an additional disentangle progress diode 145 arranged on the right of the final disentangle progress diode 144, and adapted to emit light during execution of the additional disentangling step.

[0120] Over the semi-spin dry, disentangle, main spin-dry, final disentangle, and additional disentangle progress diodes 141, 142, 143, 144, and 145, symbols or letters representing respective functions of the associated progress diodes are provided on the control panel 104.

[0121] Also, a rotary switch may be provided at the operating unit 150 to select a particular washing course, for example, a standard course, a wool/lingerie course, a boiling course, or a blue jeans course. This configuration will be described in conjunction with FIG. 13.

[0122] When the user operates the semi-dry switch 132 to wash clothes contained in the washing machine, the washing mode involving the semi-drying cycle according to the present invention is selected. Simultaneously, the semi-dry diode 134 emits light.

[0123] When the user depresses the semi-dry switch 132 in this state, washing of clothes may be set such that the washing cycle, rinsing cycle, and semi-drying cycle are executed in this order. Also, when the user operates the wash switch 111 or rinse switch 112 in the above state, the associated washing cycle or rinsing cycle may be canceled.

[0124] When a desired washing mode is inputted in the above described manner, the washing machine operates in accordance with the set washing mode to wash the clothes.

[0125] In particular, during execution of the semi-drying cycle, the semi-spin dry, disentangle, main spin-dry, final disentangle, and additional disentangle progress diodes **141**, **142**, **143**, **144**, and **145** emit light in a sequential fashion as the semi-drying cycle progresses. Accordingly, the user can identify the progress of the semi-drying cycle.

[0126] **FIG. 13** is a plan view illustrating a control apparatus for the washing machine according to another embodiment of the present invention. This control apparatus is similar to that of **FIGS. 11 and 12**, except that, in addition to the rotary switch **152**, which is provided at the operating unit **150** to select a particular washing course, that is, a standard course, a wool/lingerie course, a boiling course, or a blue jeans course, a semi-dry input unit **154** is provided at the operating unit **150**, in order to input a semi-drying mode through operation of the rotary switch **152**.

[0127] As apparent from the above description, the control apparatus according to the present invention allows the user to not only select the washing cycle, rinsing cycle, and spin-drying cycle, but also to select the semi-drying cycle. Accordingly, the cycle selection of the user can be widened. Also, where a washing mode involving the semi-drying cycle is set, the control apparatus allows the user to identify the progress of the semi-drying cycle. Thus, an improvement in convenience is achieved.

[0128] Although a few embodiments of the present invention have been shown and described, it would be appreciated by those skilled in the art that changes may be made in these embodiments without departing from the principles and spirit of the invention, the scope of which is defined in the claims and their equivalents.

What is claimed is:

1. A semi-drying method in a washing machine comprising the step of:

executing a multi-stage spin-drying process to extract water contained in clothes washed in the washing machine while gradually increasing a spin-drying speed of a drum containing the clothes such that a higher stage of the spin-drying process is executed at a higher spin-drying speed; and

rotating the drum in a stirring fashion after completion of each stage of the multi-stage spin-drying process, to execute a disentangling process.

2. The semi-drying method according to claim 1, wherein the drum is rotated at a spin-drying speed at each stage of the multi-stage spin-drying process when the clothes are maintained within an allowable unbalance range prior to execution of the stage.

3. The semi-drying method according to claim 1, wherein the drum is rotated at a spin-drying speed at each stage of the multi-stage spin-drying process for a time set such that the rotating time at one stage is longer than the rotating time at the stage preceding said one stage.

4. A semi-drying method in a washing machine comprising:

a primary semi-spin-drying step for rotating a drum at a predetermined spin-drying speed to spin dry clothes contained in the drum by a centrifugal force generated during the rotation of the drum;

a primary disentangling step for rotating the drum in a stirring fashion to disentangle the clothes, after completion of the primary semi-spin-drying step;

a secondary semi-spin-drying step for rotating the drum at a spin-drying speed higher than at the primary semi-spin-drying step, after completion of the primary disentangling step;

a secondary disentangling step for rotating the drum in a stirring fashion to disentangle the clothes, after completion of the secondary semi-spin-drying step;

a main spin-drying step for rotating the drum at a high spin-drying speed to spin-dry the clothes at a water extraction rate higher than at the secondary semi-spin-drying step, after completion of the secondary disentangling step; and

a final disentangling step for rotating the drum in a stirring fashion to disentangle the clothes, after completion of the main spin-drying step.

5. The semi-drying method according to claim 4, wherein, when the clothes are maintained within an allowable unbalance range prior to execution of each of the primary semi-spin-drying step, secondary semi-spin-drying step, and main spin-drying step, the drum is rotated at the spin-drying speed, which is predetermined for the associated spin-dry step.

6. The semi-drying method according to claim 4, wherein respective rotating times, for which the drum is rotated at the primary and secondary semi-spin-drying steps, are set such that the rotating time at the secondary semi-spin-drying step is longer than the rotating time at the primary semi-spin-drying step.

7. The semi-drying method according to claim 4, wherein the secondary semi-spin-drying step and the secondary disentangling step are further repeatedly executed a plurality of times in an alternating fashion; and

respective spin-drying speeds of the drum at the repeated secondary semi-spin-drying steps are set such that the spin-drying speed at one semi-spin-drying step is higher than the spin-drying speed at the semi-spin-drying step preceding said one semi-spin-drying step.

8. The semi-drying method according to claim 7, wherein respective rotating times, for which the drum is rotated at the repeated secondary semi-spin-drying steps, are set such that the rotating time at one secondary semi-spin-drying step is longer than the rotating time at the semi-spin-drying step preceding said one secondary semi-spin-drying step.

9. The semi-drying method according to claim 4, wherein the spin-drying speed of the drum at the main spin-drying step is set to be higher than the spin-drying speed of the drum at the secondary semi-spin-drying step.

10. The semi-drying method according to claim 4, wherein the spin-drying speed of the drum at the main spin-drying step is set, based on an unbalance of the clothes sensed after completion of the secondary disentangling step.

11. The semi-drying method according to claim 10, wherein a rotating time, for which the drum is rotated at the main spin-drying step, is set such that the rotating time is increased as the set spin-drying speed of the drum at the main spin-drying step decreases.

12. The semi-drying method according to claim 10, wherein the spin-drying speed of the drum at the main spin-drying step is increased in a step-wise fashion from the set spin-drying speed of the drum, as the main spin-drying step progresses.

13. The semi-drying method according to claim 10, further comprising:

a re-disentangling step for rotating the drum in a stirring fashion when the spin-drying speed of the drum set for the main spin-drying step is lower than a predetermined speed, prior to execution of the main spin-drying step.

14. The semi-drying method according to claim 4, further comprising:

an additional disentangling step for rotating the drum in a stirring fashion when the clothes have been maintained in the drum until a predetermined time elapses after completion of the final disentangling step.

15. The semi-drying method according to claim 14, wherein the additional disentangling step is repeatedly executed at intervals of a predetermined time until the clothes are taken out of the drum.

16. The semi-drying method according to claim 14, wherein the additional disentangling step comprises the steps of comparing a load generated during a rotation of the drum at the additional disentangling step, which is currently executed, with a predetermined load, and determining, based on the result of the comparison, whether or not the clothes have been taken out of the drum.

17. The semi-drying method according to claim 14, wherein the additional disentangling step further comprises the step of turning off the washing machine when it is determined that the clothes have been taken out of the drum.

18. A washing method in a washing machine comprising:

a rinsing cycle for repeatedly executing, a plurality of times, a rinsing process adapted to supply wash water into a drum containing clothes, and then to rotate the drum to rinse the clothes, and a draining process adapted to drain the wash water, while heating the wash water supplied in at least a final one of the repeated rinsing processes; and

a semi-drying cycle for executing a multi-stage spin-drying process in such a manner that the drum is rotated at spin-drying speeds set for respective stages of the multi-stage spin-drying process to spin-dry the clothes by a centrifugal force generated during the rotation of the drum, and rotating the drum in a stirring fashion to disentangle the clothes after completion of each stage of the multi-stage spin-drying process.

19. The washing method according to claim 18, further comprising:

a spin-drying cycle for rotating the drum at a high spin-drying speed for a time shorter than an execution time of the semi-drying cycle, to spin-dry the clothes by a centrifugal force generated during the rotation of the drum,

wherein the spin-drying cycle or the semi-drying cycle is selectively executed.

20. The washing method according to claim 18, wherein the semi-drying cycle comprises:

a primary semi-spin-drying step for rotating the drum at a predetermined spin-drying speed;

a primary disentangling step for rotating the drum in a stirring fashion to disentangle the clothes, after completion of the primary semi-spin-drying step;

a secondary semi-spin-drying step for rotating the drum at a spin-drying speed higher than at the primary semi-spin-drying step, after completion of the primary disentangling step;

a secondary disentangling step for rotating the drum in a stirring fashion to disentangle the clothes, after completion of the secondary semi-spin-drying step;

a main spin-drying step for rotating the drum at a high spin-drying speed to spin-dry the clothes at a water extraction rate higher than at the secondary semi-spin-drying step, after completion of the secondary disentangling step; and

a final disentangling step for rotating the drum in a stirring fashion to disentangle the clothes, after completion of the main spin-drying step.

21. The semi-drying method according to claim 20, wherein the spin-drying speed of the drum at the main spin-drying step is set to be higher than the spin-drying speed of the drum at the secondary semi-spin-drying step.

22. The semi-drying method according to claim 20, wherein the spin-drying speed of the drum at the main spin-drying step is set, based on an unbalance of the clothes sensed after completion of the secondary semi-spin-drying step.

23. The semi-drying method according to claim 18, further comprising:

an additional disentangling step for rotating the drum in a stirring fashion when the clothes have been maintained in the drum until a predetermined time elapses after completion of the semi-drying cycle.

24. A control apparatus for a washing machine comprising:

an operating unit adapted to allow a user to input a washing mode, and to display the progress of a washing operation carried out in the washing machine; and

a semi-dry input unit provided at the operating unit, and adapted to allow the user to input a semi-drying mode, in which a multi-stage spin-drying process is executed in such a manner that a drum is rotated at spin-drying speeds set for respective stages of the multi-stage spin-drying process to extract water from clothes contained in the drum, and the drum is rotated in a stirring fashion to disentangle the clothes after completion of each stage of the multi-stage spin-drying process.

25. The control apparatus according to claim 24, further comprising:

a semi-dry display unit provided at the operating unit, and adapted to display the progress of the semi-drying mode.

\* \* \* \* \*