

J. S. Adams,

2, Sheets, Sheet 2.

Truss Bridge.

No. 106,700.

Patented Aug. 30. 1870.

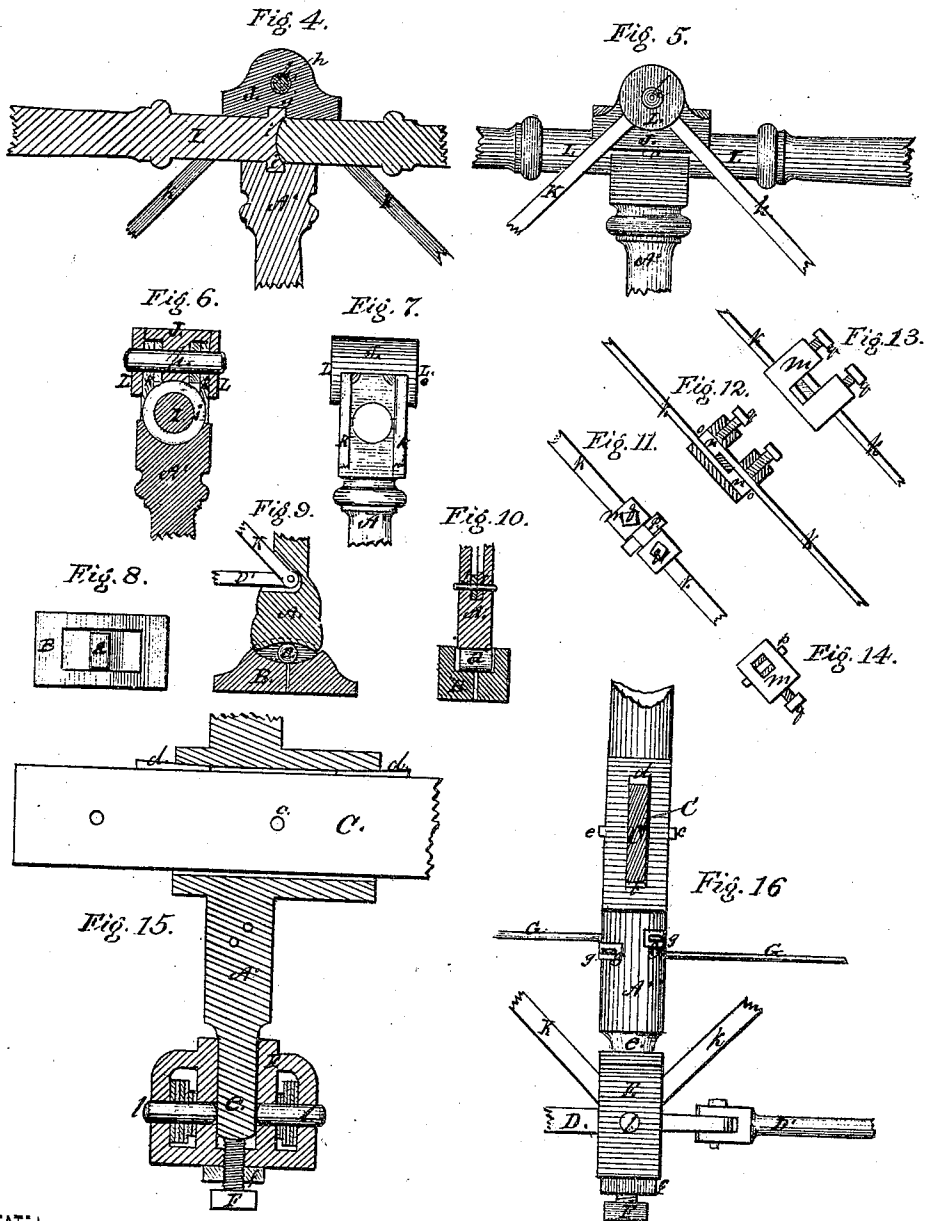

Witnesses.

Chas. H. Coole
Geo. H. Hopkins

Inventor

John S. Adams

UNITED STATES PATENT OFFICE.

JOHN S. ADAMS, OF ELGIN, ILLINOIS.

IMPROVEMENT IN TRUSS-BRIDGES.

Specification forming part of Letters Patent No. 106,760, dated August 30, 1870.

To all whom it may concern:

Be it known that I, JOHN S. ADAMS, of the city of Elgin, in the county of Kane and State of Illinois, have invented certain new and useful Improvements in Iron Truss-Bridges; and the following is a full, clear, and exact description of the same, reference being had to the accompanying drawing, making a part of this specification, in which—

Plate I—Figure 1 represents a side elevation of three sections or panels of the bridge. Fig. 2 shows a plan or top view of the bridge with the planking removed. Fig. 3 shows an end elevation of the bridge structure. Plate II—Fig. 4 represents a vertical longitudinal section of the post, upper chord, saddle, coupling-pin, and diagonal ties. Fig. 5 shows a side elevation of the same. Fig. 6 is a transverse vertical section of same. Fig. 7 is an end view of the same. Fig. 8 shows a plan of the supporting-block and roller on which the structure rests. Fig. 9 shows a sectional side view of the supporting-block, roller, foot of an end post, diagonal tie, and the connection of the jointed tension-brace. Fig. 10 is a transverse vertical section of the same. Fig. 11 shows a side view of the center diagonal tie and tension-clamp. Fig. 12 shows a transverse longitudinal section of the same. Fig. 13 is a top view of the tension-clamp. Fig. 14 shows an end view of the same. Fig. 15 represents a vertical transverse section of the lower portion of an intermediate post and the stirrup, showing the position of the girder-beam and its connections and fastenings, the elevating screw and nut; also the connections of the lower chord and diagonal ties. Fig. 16 is a side view of the same, showing also the jointed tension-brace and the connections of the horizontal truss-ties.

The object of my invention is to provide means for the accurate adjustment of the camber and equalization of the strain upon the several parts of an iron truss-bridge, to give freedom of motion under the contraction and expansion consequent upon changes of temperature, and also to provide for the convenient attachment of sidewalks; and it consists, first, in the form and construction of the truss-posts and the manner of attaching them to the girder-beams; second, in a swivel-stirrup

at the foot of each intermediate post, to equalize the strain upon each part of the lower chord; third, in the method of forming the joints of the upper chord sections; fourth, in the manner of mounting friction-rollers under the foot of each end post; fifth, in the mode of attaching sidewalks.

To enable others to construct my improved iron truss-bridge, I will describe it more in detail, referring to the drawing.

The abutments and piers should be made of solid masonry, of suitable dimensions to receive the structure, which is entirely supported on the four corner or end posts, A A A A.

The base or step of each of the posts is made concave, and they rest on anti-friction rollers *a a a a*. Said rollers are placed in reverse concave recesses made in the cast-iron supporting-blocks B B, which rest upon and may be secured to the piers and abutments.

The end posts, A A, and the intermediate posts, A' A', are made of cast-iron, of any desirable pattern, either plain or ornamental, with a long sleeve-opening, *b*, in the lower portion, to receive the iron girder or cross-beam C, on which the bridge-floor is laid. A large bolt or pin, *c*, is placed through the post A and the girder C, and secures the connection of the said post and girder.

It will be observed that the girder does not rest upon the bottom of the sleeve-opening *b*, but upon the pin *c*, which, in that way, becomes a bearing-point upon which the post and girder may move while being relatively adjusted, and the necessity of this arrangement will be at once apparent, from the fact that, if the girder C should rest upon the bottom of the sleeve-opening, any movement of the post sidewise would tend to raise the girder C upon one or the other edges of the bottom of the opening *b*, so that the posts A A' could not be adjusted in a line to receive the top chord, I, nor could they be plumbed up in a vertical position by driving the wedges *d d* between the top of the sleeve-opening *b* and the girder C, as can be easily done, as shown, and the post and girder are thereby rigidly locked in their proper relative position.

The lower end of each intermediate post, A', is provided with a journal, *e*, on which the

stirrup E is pivoted, so that it will turn sufficiently to equalize the strain upon the several parts of the lower chord, D, the lower end of the journal *e* resting upon the end of the elevating-screw F, by means of which the posts A' may be raised to adjust the camber of the bridge, the screw F being provided with a jam-nut, *f*, to hold it in place when adjusted.

Below the girders C C the horizontal diagonal ties G G are attached to the posts A' by passing through the body of the post, or ears cast on them for the purpose, they being secured by nuts *g g* on screw-threads at both ends, so that a suitable degree of tension may be given them.

On the girders C C floor-joist or string-pieces H H may be placed to secure the plank to, which may be straight, crosswise, or diagonal, the posts A' extending to any desired height above the floor proportional with the length of the span. The top ends of the posts are cast or bored to fit the cylindrical ends of the upper chord, I, and the annular flange or rim *i* made thereon.

The top chord, I, is made or cast in sections in length corresponding with the length of the panels. One end of each section is made with a terminal concave socket and an annular flange, *i*. The other end is made convex to fit into the corresponding concave socket of the adjoining section. The center section is made with both the ends concave, and flanges *i i* to reverse the positions of the joint on each side of the center, so that any required number of sections may be used.

The end sections of the upper chord, I, may extend out beyond the posts A and saddle J a sufficient distance to make an appropriate finish. The cap or saddle J is cast of metal, the under side formed to fit the cylindrical ends of the upper cord, I, with a corresponding groove, *j*, to fit the annular flange *i*.

The diagonal ties K and counter-ties *k* are secured to the saddle J by the coupling pins or bolts *h*. The ends of the ties are enlarged to form eyes for the pins *h*, and the caps L are placed over them on the outside to protect the joint and make a finish.

The lower ends of the diagonal ties K *k* are secured in the opening of the stirrups E by pins *l l* on both sides of the journal *e*, pins passing also through the ends of the lower chord, D and D', of the end sections. The counter-ties *k* are provided with buckle-clamp *m*, made of one piece of metal, with openings

o o, through which the two parts of the tie *k k'* pass, the braces or counter-ties being made of flat iron bars, the ends doubled over and welded, forming strong lugs *n n*, between which a key, *p*, is driven to produce the requisite tension, when it is firmly secured by set-screws *q q* fitted in the clamp *m*.

The bridge structure, as above described, being the required width for street or road purposes, the iron girders C C are made to extend out beyond the outside of the posts A A' a sufficient distance to support on each one of them a sleeve-bracket or supplemental beam, M, and railing-post N, so that a sidewalk can be made and attached to one or both sides of the bridge at pleasure, the brackets M being secured to the beams C by a key or pin, *v*.

An iron truss-bridge constructed as above described may be comparatively light, strong, and durable, as the contraction and expansion of the metal are equalized throughout, and the vibration provided for in the adjustment of the camber.

What I claim as my invention, and desire to secure by Letters Patent, is—

1. The posts A and A', constructed with the long sleeve-openings *b b*, to receive the iron girder-beams C C, substantially as and for the purposes described.

2. The large bolt or pin *c*, to support the girder-beam C in the sleeve *b* of the post A, in combination with the keys *d d*, for plumbing and holding the post A in a vertical position, as herein set forth.

3. The swivel-stirrups E E, as constructed, in combination with the posts A' A' for equalizing the strain on the chord D D' and diagonal ties, as specified.

4. The upper chord, I, constructed with concave and convex ends to fit each other, with their annular flanges *i i* to fit in the grooves in the top of the posts A' A and saddle J, as and for the purpose specified.

5. The sleeve-brackets or supplementary beams M, attached to the outer ends of the girder cross-beams C, for supporting the sidewalks and railings, substantially in the manner as specified.

In testimony whereof I have hereunto subscribed my name.

JOHN S. ADAMS.

Witnesses:

J. B. WOODRUFF,
J. R. HOPKINS.