



US010821774B2

(12) **United States Patent**
Celik et al.

(10) **Patent No.:** **US 10,821,774 B2**

(45) **Date of Patent:** **Nov. 3, 2020**

(54) **NON-PNEUMATIC SUPPORT STRUCTURE**

(71) Applicant: **The Goodyear Tire & Rubber Company**, Akron, OH (US)

(72) Inventors: **Ceyhan Celik**, Stow, OH (US); **Steven Amos Edwards**, Akron, OH (US)

(73) Assignee: **The Goodyear Tire & Rubber Company**, Akron, OH (US)

(*) Notice: Subject to any disclaimer, the term of this patent is extended or adjusted under 35 U.S.C. 154(b) by 0 days.

(21) Appl. No.: **16/511,217**

(22) Filed: **Jul. 15, 2019**

(65) **Prior Publication Data**

US 2019/0337328 A1 Nov. 7, 2019

Related U.S. Application Data

(62) Division of application No. 15/795,781, filed on Oct. 27, 2017, now Pat. No. 10,406,852.

(51) **Int. Cl.**

B60B 9/00	(2006.01)
B60B 9/26	(2006.01)
B60C 7/10	(2006.01)
B60B 21/06	(2006.01)
B60C 7/18	(2006.01)
B60B 19/04	(2006.01)
B60B 21/00	(2006.01)

(52) **U.S. Cl.**

CPC **B60B 9/005** (2013.01); **B60B 9/26** (2013.01); **B60B 19/04** (2013.01); **B60B 21/00** (2013.01); **B60B 21/06** (2013.01); **B60C 7/10** (2013.01); **B60C 7/18** (2013.01); **B60B 9/00** (2013.01)

(58) **Field of Classification Search**

CPC B60B 9/005; B60B 19/04; B60B 21/00; B60B 9/26; B60B 21/06; B60B 9/00; B60C 7/18; B60C 7/10

USPC 301/100
See application file for complete search history.

(56) **References Cited**

U.S. PATENT DOCUMENTS

479,255 A	7/1892	Dunlop
482,175 A	9/1892	Hollafolla
1,002,003 A	8/1911	Simonson et al.
1,233,722 A	7/1917	Smith

(Continued)

Primary Examiner — S. Joseph Morano

Assistant Examiner — Jean W Charleston

(74) *Attorney, Agent, or Firm* — Robert N. Lipschik

(57) **ABSTRACT**

An adjustable rim includes a first annular ring rotatable about a first axis, the first ring having radially extending first linear slots circumferentially spaced about the first ring, a first annular adjustment hoop rotatable about the first axis, the first hoop having circumferentially and radially extending first arcuate slots spaced about the first hoop, a second annular ring rotatable about a second axis, the second ring having radially extending second linear slots circumferentially spaced about the second ring, a second annular adjustment hoop rotatable about the second axis, the second hoop having circumferentially and radially extending second arcuate slots spaced about the second hoop, and an axially extending arcuate member having a first axial end and a second axial end. The first axial end is circumferentially and radially aligned with a first linear slot of the first annular ring and a first arcuate slot of the first annular hoop. The first linear slot and the first arcuate slot interact to move part of the arcuate member in only a radial direction.

10 Claims, 9 Drawing Sheets

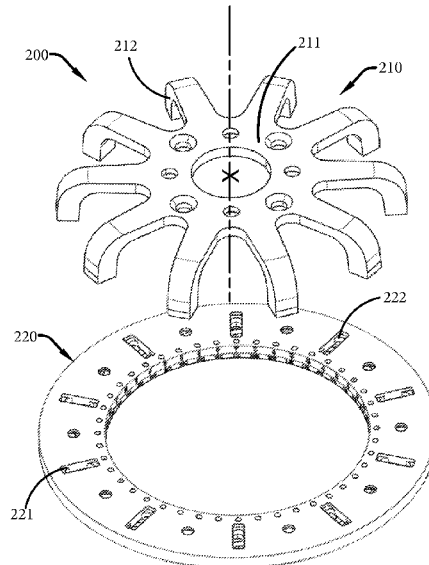

(56)

References Cited

U.S. PATENT DOCUMENTS

1,389,285	A	8/1921	Althoff	
1,451,517	A	4/1923	Smith	
1,930,764	A	10/1933	Mallory	
3,493,027	A	2/1970	Dewhirst et al.	
4,226,273	A	10/1980	Long et al.	
4,235,270	A *	11/1980	Kahaner	B60B 9/12 152/326
4,602,823	A	7/1986	Berg	
5,343,916	A *	9/1994	Duddey	B60C 7/12 152/326
5,800,643	A	9/1998	Frankowski	
6,068,721	A	5/2000	Dyer et al.	
7,604,035	B2	10/2009	Lehr et al.	
8,091,596	B2 *	1/2012	Louden	B60B 9/02 152/5
8,950,451	B2 *	2/2015	Abe	B60C 7/22 152/80
8,962,120	B2 *	2/2015	Delfino	B60B 9/02 428/66.6
9,321,312	B2 *	4/2016	Asper	B60C 7/102
2004/0069385	A1	4/2004	Timoney et al.	
2010/0193097	A1	8/2010	McNier et al.	
2016/0114623	A1 *	4/2016	Smith	B60C 7/24 301/11.1
2019/0126673	A1	5/2019	Celik et al.	

* cited by examiner

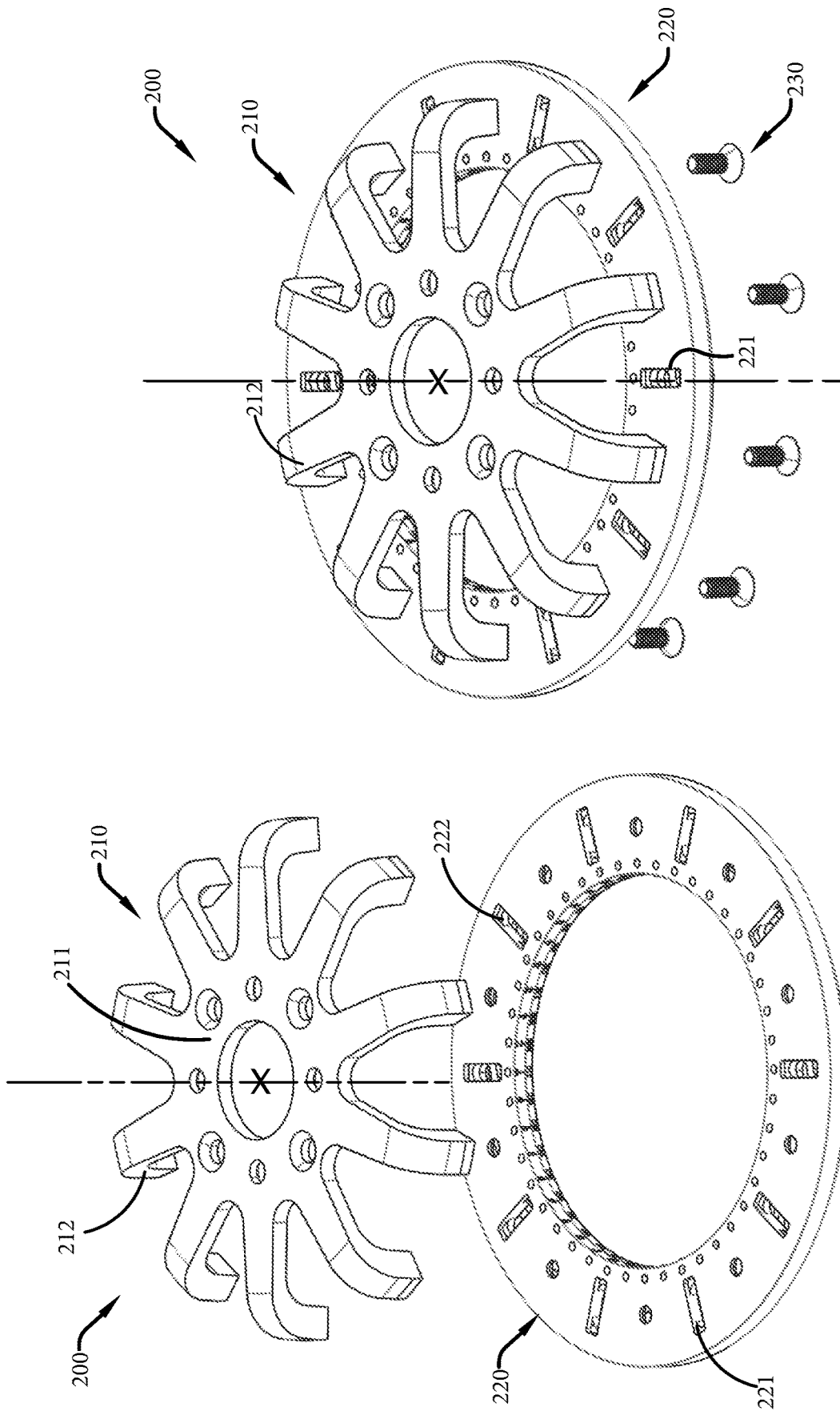

FIG. 2

FIG. 1

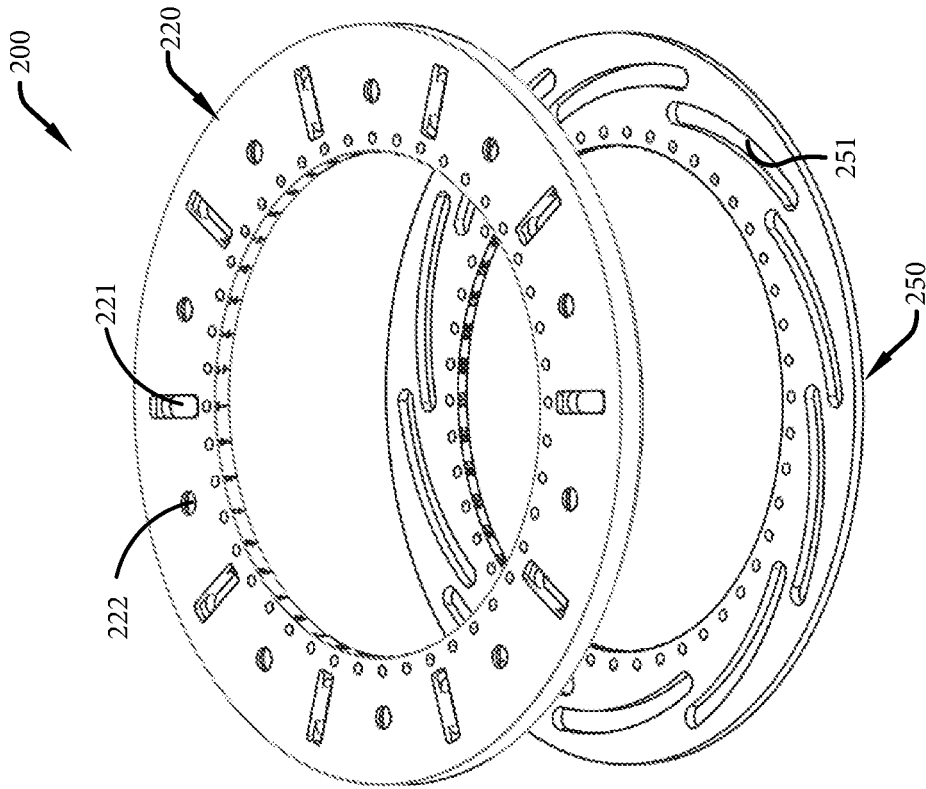

FIG. 4

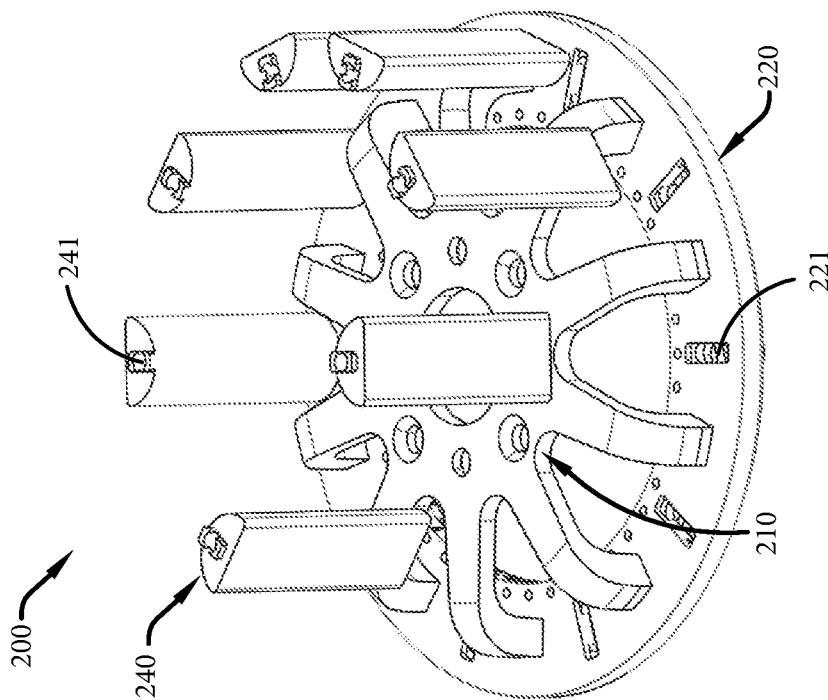

FIG. 3

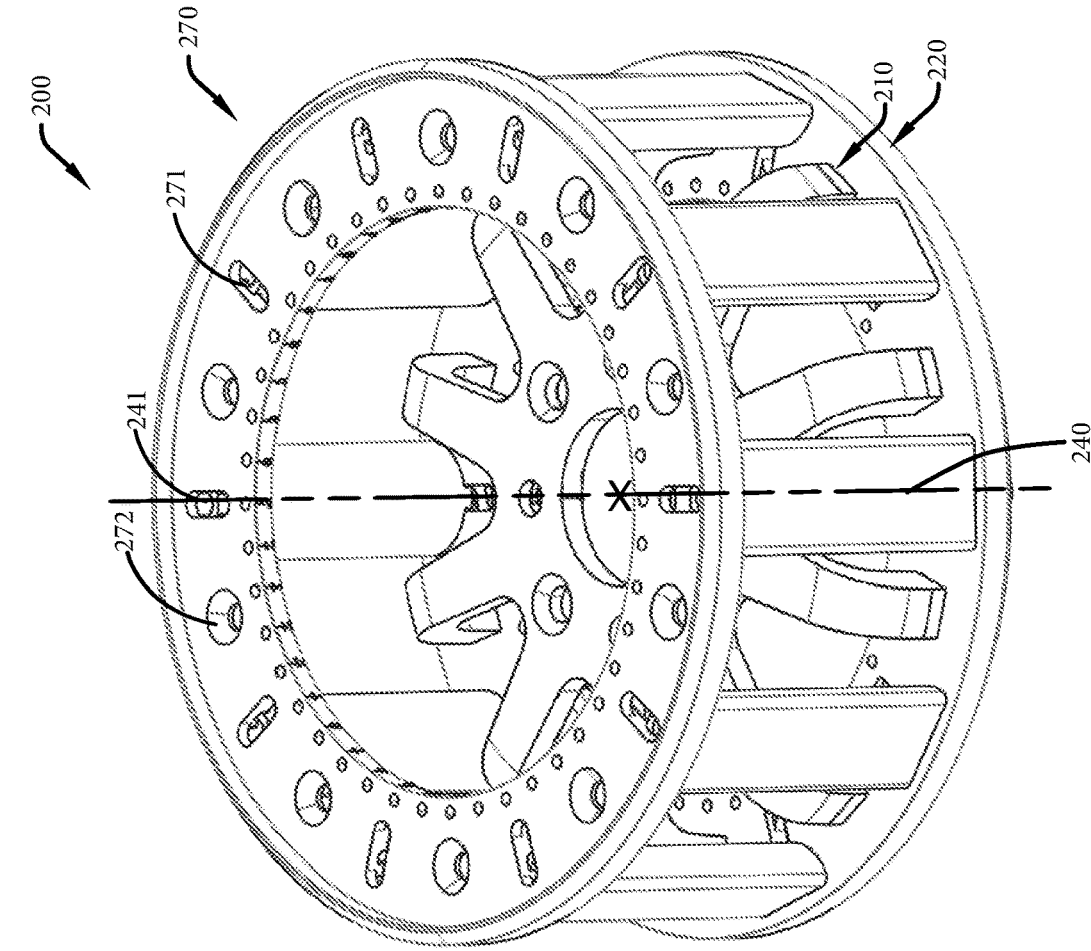

FIG. 5

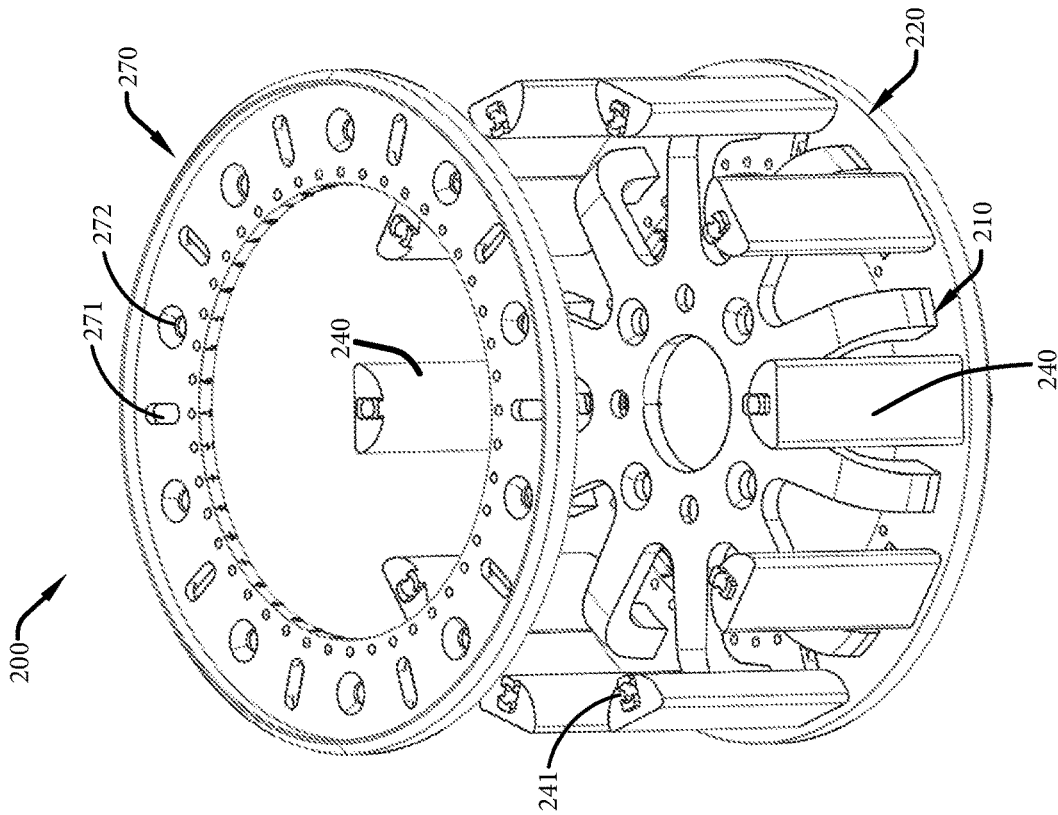

FIG. 6

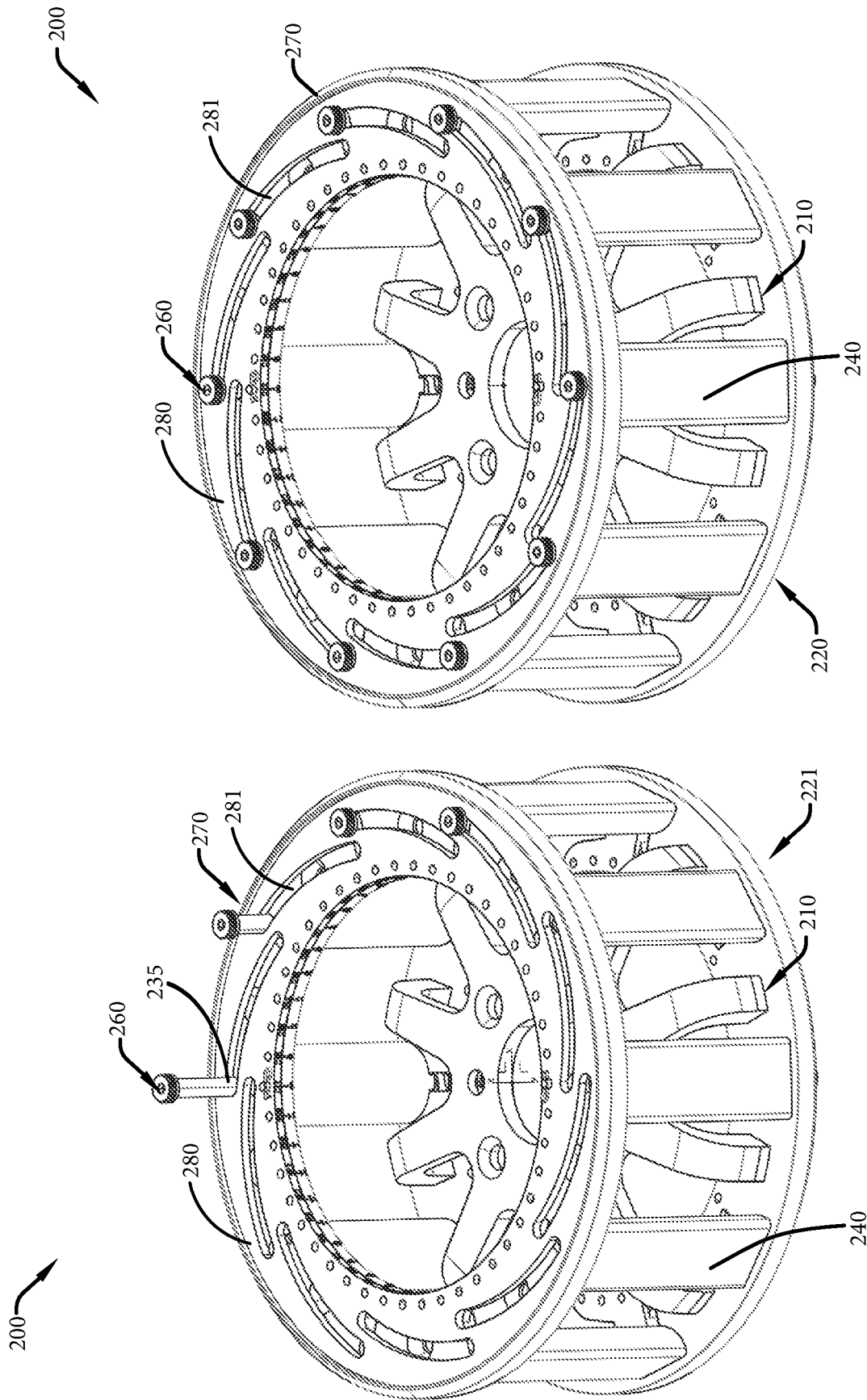

FIG. 8

FIG. 7

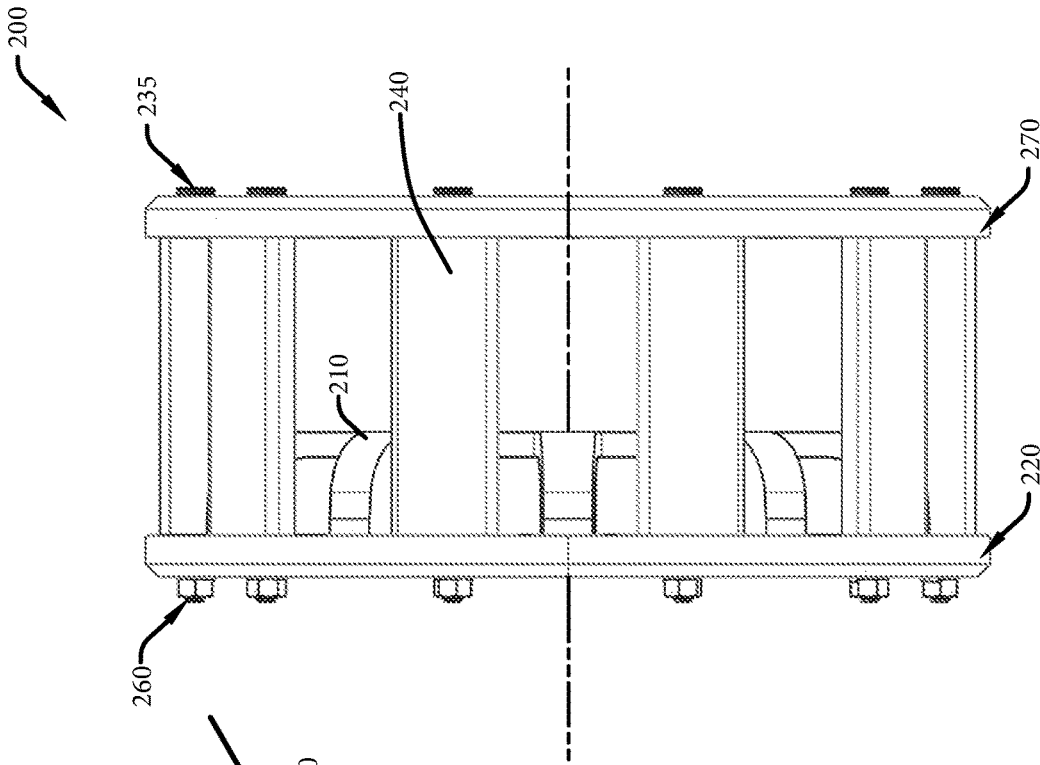

FIG. 10

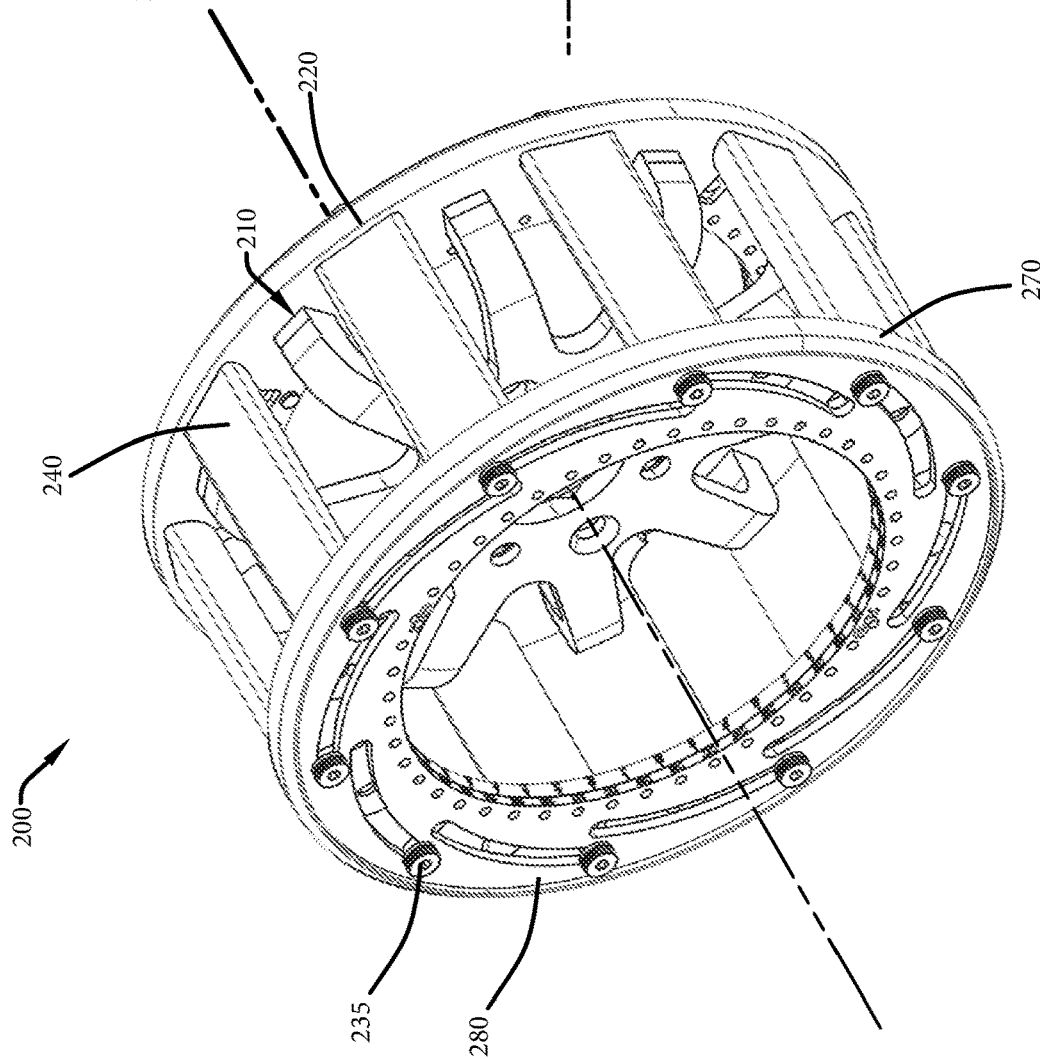

FIG. 9

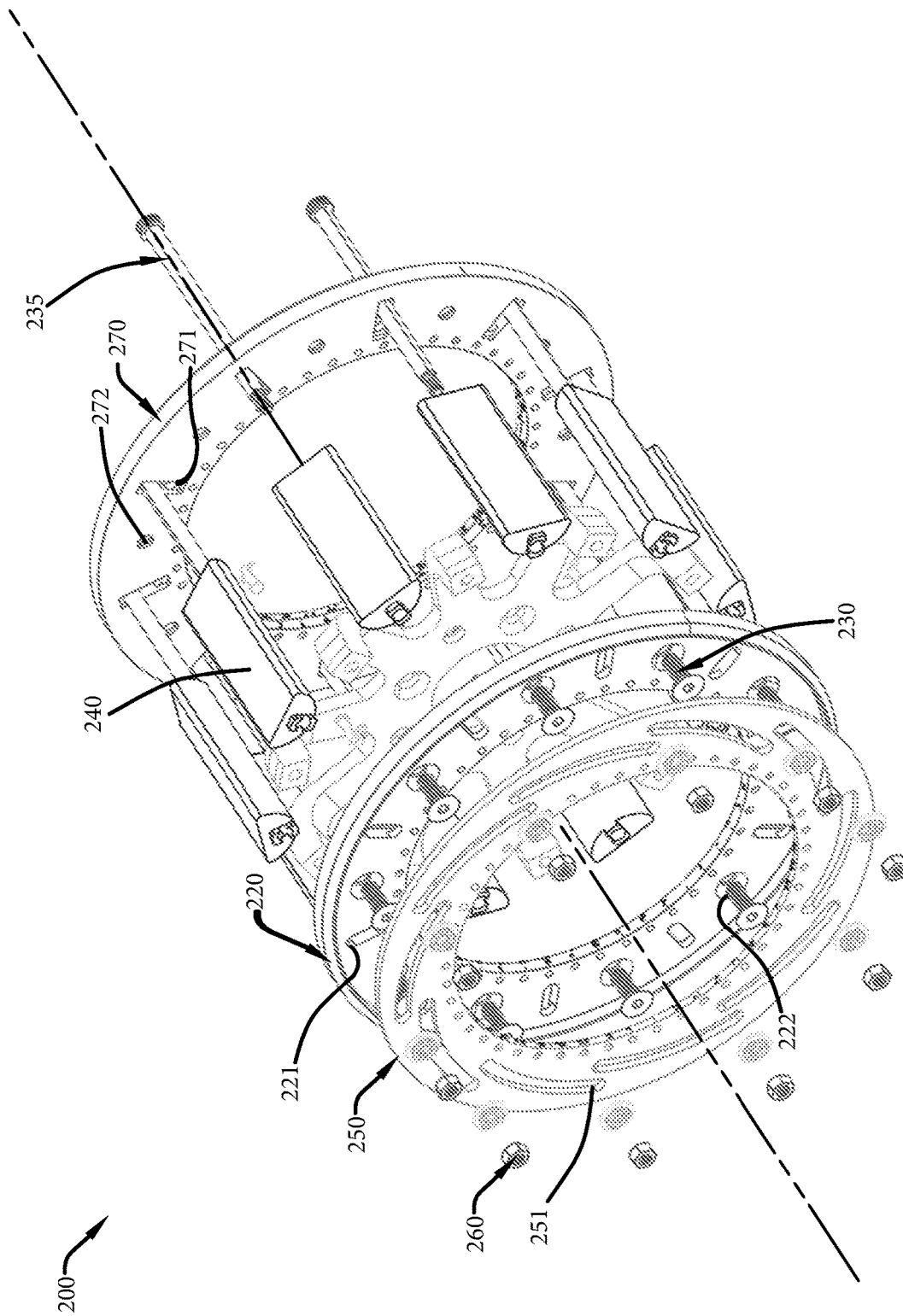

FIG. 11

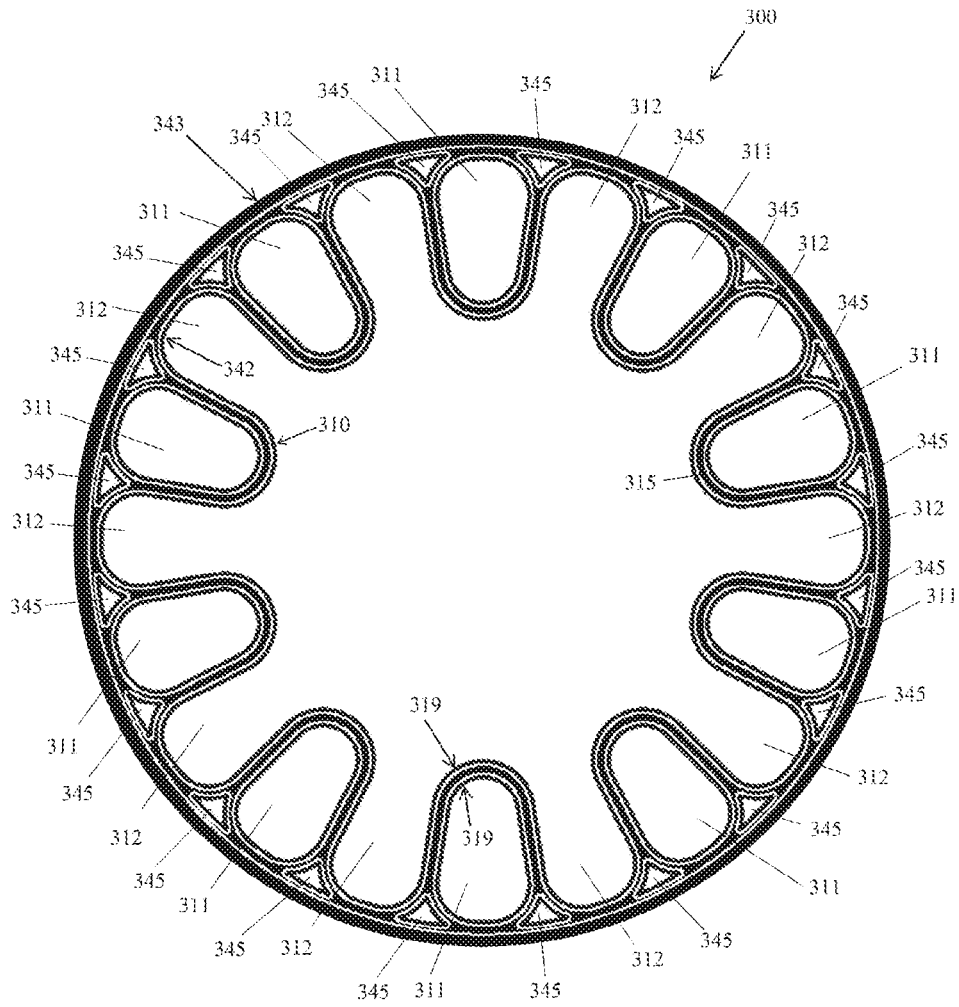

FIG. 12

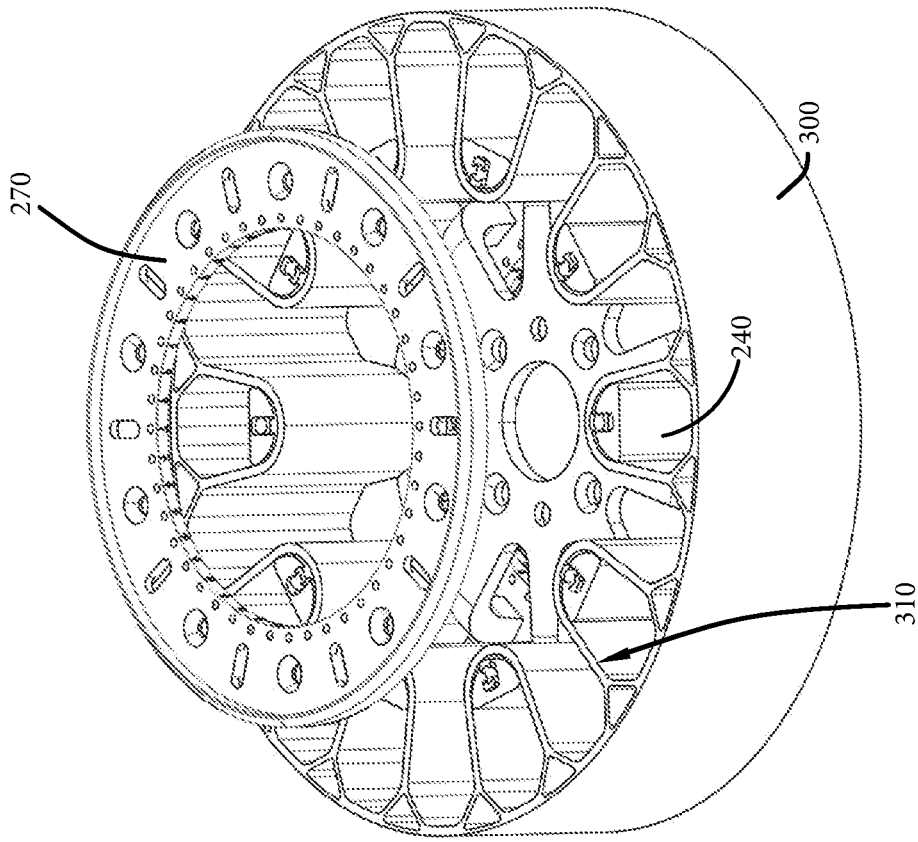

FIG. 14

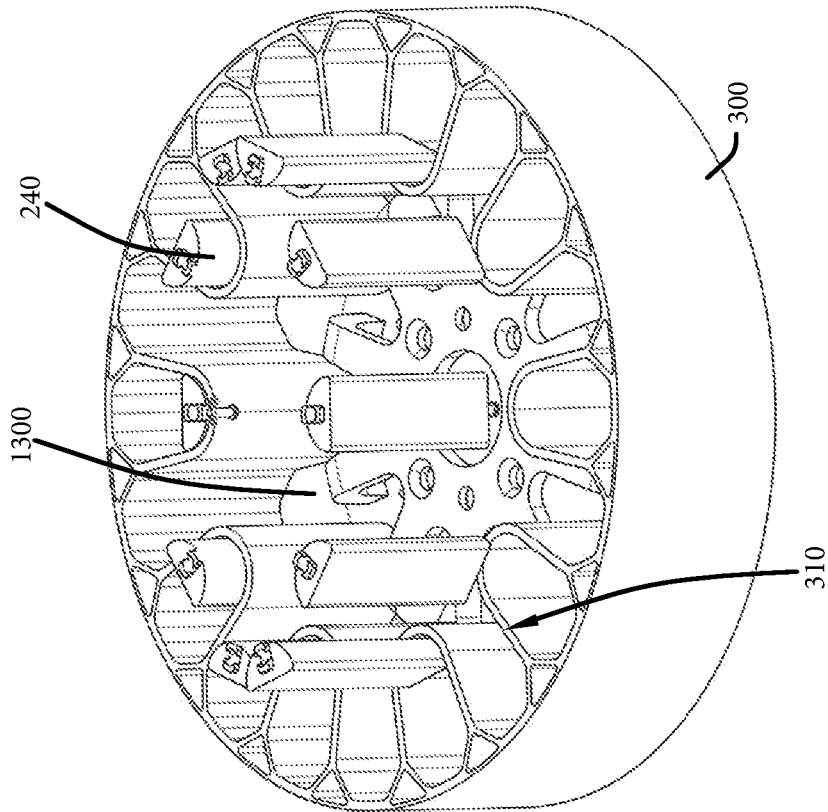

FIG. 13

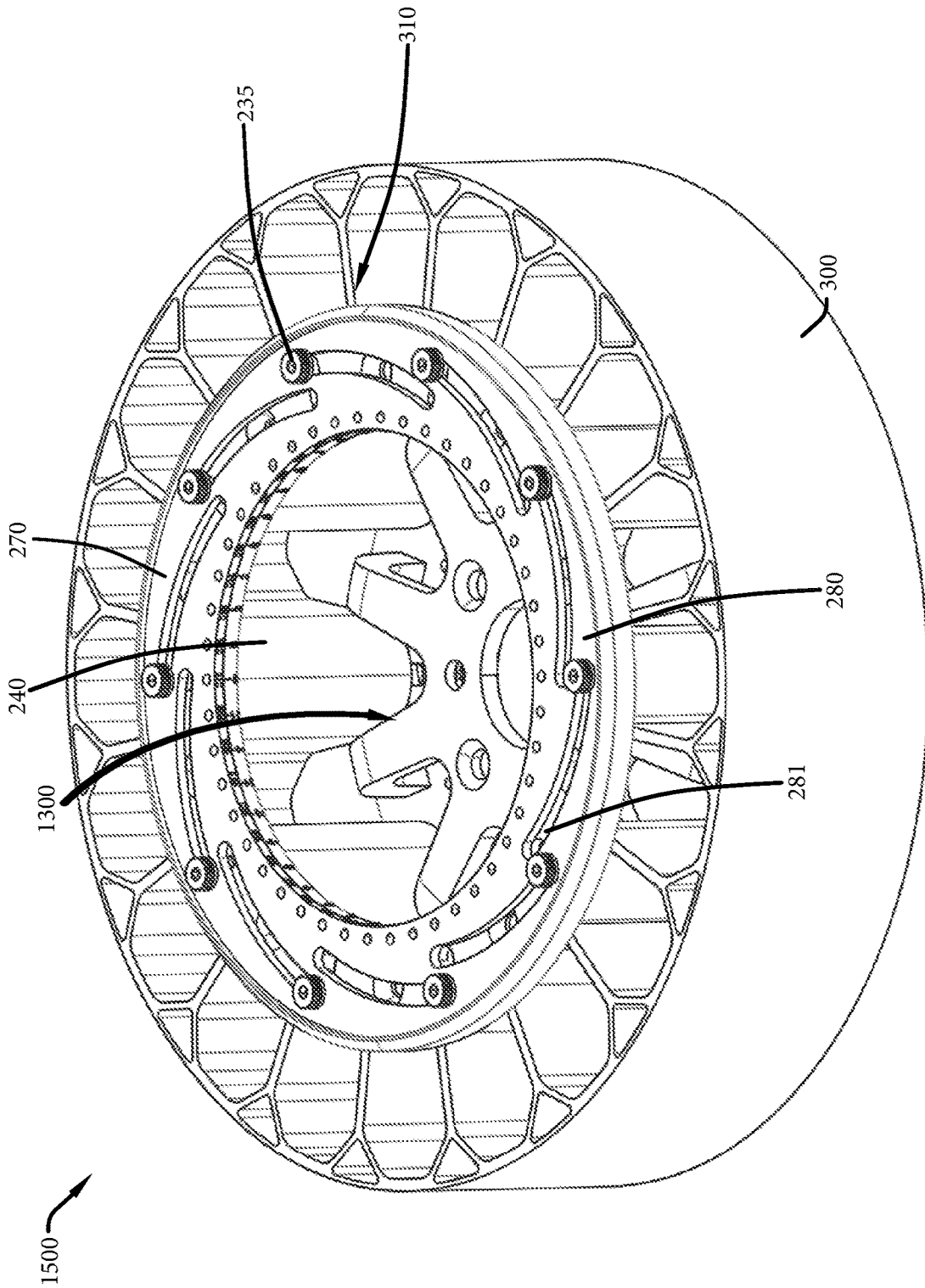

FIG. 15

NON-PNEUMATIC SUPPORT STRUCTURE

FIELD OF INVENTION

The present invention relates to wheel/tire assemblies, and more particularly, to non-pneumatic wheel/tire assemblies.

BACKGROUND OF THE INVENTION

Radial pneumatic tires rely on the ply reinforcement to carry and transfer the load between the rim and the belt layer. These ply cords need to be tensioned to carry the load. Tensioning of these ply cords is achieved with the pressurized air in the inner chamber of the tire. If air pressure is lost, load carrying capacity of a pneumatic tire decreases significantly. Preventing the slow or sudden air pressure loss has been a challenge for the tire makers. One proposed solution is to use non-pneumatic tires. A top loader non-pneumatic tire can perform similar to a pneumatic tire if its durability, speed rating/limit and load capacity can be increased to the levels of a pneumatic tire.

Many top loader non-pneumatic tires rely on the polymeric spokes to carry the load of the vehicle. Spokes transfer the load from the rim to the shear band. Due to the characteristics of the polymeric materials used in the spokes of these tires, performance of these tires are limited. It is an object of the present invention to overcome this limitation and increase the load carrying capacity and durability of these spokes and hence the performance of the top loader non-pneumatic tire.

SUMMARY OF THE INVENTION

An adjustable rim in accordance with the present invention includes a first annular ring rotatable about a first axis, the first ring having radially extending first linear slots circumferentially spaced about the first ring, a first annular adjustment hoop rotatable about the first axis, the first hoop having circumferentially and radially extending first arcuate slots spaced about the first hoop, a second annular ring rotatable about a second axis, the second ring having radially extending second linear slots circumferentially spaced about the second ring, a second annular adjustment hoop rotatable about the second axis, the second hoop having circumferentially and radially extending second arcuate slots spaced about the second hoop, and an axially extending arcuate member having a first axial end and a second axial end. The first axial end is circumferentially and radially aligned with a first linear slot of the first annular ring and a first arcuate slot of the first annular hoop. The first linear slot and the first arcuate slot interact to move part of the arcuate member in only a radial direction.

According to another aspect of the adjustable rim, the second axial end is circumferentially and radially aligned with a second linear slot of the second annular ring and a second arcuate slot of the annular second hoop, the second slot and the second arcuate slot interacting to move part of the arcuate member in only a radial direction.

According to still another aspect of the adjustable rim, rotation of the first annular hoop relative to the first annular ring about the first axis moves the first axial end of the arcuate member in the radial direction.

According to yet another aspect of the adjustable rim, rotation of the second annular hoop relative to the second annular ring about the second axis moves the second axial end of the arcuate member in the radial direction.

According to still another aspect of the adjustable rim, the first axis and the second axis are coincident.

According to yet another aspect of the adjustable rim, the arcuate member engages a spoke structure and radial movement of the arcuate member alters an amount of radial tension placed on the spoke structure.

According to still another aspect of the adjustable rim, a support member is attached to the first annular ring. The support member has a cylindrical hub and radially protruding extensions projecting radially outward from the cylindrical hub.

According to yet another aspect of the adjustable rim, the arcuate member has an axial bore extending through the arcuate member.

According to still another aspect of the adjustable rim, a shaft bolt is axially inserted through the first annular ring, the first annular hoop, the axial bore of the arcuate member, the second annular ring, and the second annular hoop.

According to yet another aspect of the adjustable rim, a fastener nut is fixed to the shaft bolt thereby axially securing the first annular ring, the first annular hoop, the arcuate member, the second annular ring, and the annular second hoop together.

A first method in accordance with the present invention adjusts radial tension placed on a spoke structure. The method includes the steps of: rolling a first annular ring about an axis; fixing the first annular ring to a first annular hoop; rolling a second annular ring about the axis; fixing the second annular ring to a second annular hoop; attaching the spoke structure to the first annular ring and the second annular ring; rotating the first annular hoop relative to the first annular ring about the axis; rotating the second annular hoop relative to the second annular ring about the axis; moving an arcuate member radially relative to the axis; and altering radial tension of the spoke structure.

According to another aspect of the first method, another step extends a first linear slot in the first annular ring.

According to still another aspect of the first method, another step extends a first arcuate slot in the first annular hoop.

According to yet another aspect of the first method, another step radially moves an arcuate member relative to the axis by interaction between the first linear slot and the first arcuate slot.

According to another aspect of the first method, another step moves an arcuate member relative to the axis by circumferential and radial motion between the first linear slot relative to the first arcuate slot.

A second method in accordance with the present invention adjusts radial tension placed on a spoke structure. The method includes the steps of: rolling a first annular ring and a second annular ring about an axis; attaching the spoke structure to the first annular ring and the second annular ring; unfixing the first annular ring from a first annular hoop; unfixing the second annular ring from a second annular hoop; rotating the first annular hoop relative to the first annular ring about the axis; rotating the second annular hoop relative to the second annular ring about the axis; altering radial tension of the spoke structure; refixing the first annular ring to the first annular hoop; and refixing the second annular ring to the second annular hoop.

According to another aspect of the second method, another step aligns an arcuate member circumferentially and radially with the first annular ring, the first annular hoop, the second annular ring, and the second annular hoop.

According to still another aspect of the second method, another step rotates the first annular hoop relative to the first annular ring about the first axis.

According to yet another aspect of the second method, another step rotates the second annular hoop relative to the second annular ring about the axis.

According to still another aspect of the second method, another step moves the arcuate member relative to the axis.

BRIEF DESCRIPTION OF THE DRAWINGS

The present invention will be more clearly understood by the following description of some examples thereof, with reference to the accompanying drawings, in which:

FIG. 1 is a schematic perspective view of part of an example assembly in accordance with the present invention;

FIG. 2 is a schematic perspective view of another part of the example assembly added to the part of FIG. 1;

FIG. 3 is a schematic perspective view of still another part of the example assembly added to the parts of FIG. 2;

FIG. 4 is a schematic perspective view of yet another part of the example assembly added to the parts of FIG. 3;

FIG. 5 is a schematic perspective view of yet another part of the example assembly added to the parts of FIG. 4;

FIG. 6 is a schematic perspective view of yet another part of the example assembly added to the parts of FIG. 5;

FIG. 7 is a schematic perspective view of yet another part of the example assembly added to the parts of FIG. 6;

FIG. 8 is a schematic perspective view of still another part of the example assembly added to the parts of FIG. 7;

FIG. 9 is another schematic perspective view of the example assembly of FIG. 8;

FIG. 10 is a schematic elevation view of the example assembly of FIG. 9;

FIG. 11 is a schematic exploded perspective view of the example assembly of FIGS. 8 & 9;

FIG. 12 is a schematic section view of an example tire for use with the example assembly of FIGS. 1-11;

FIG. 13 is a schematic perspective view of the example assembly of FIG. 3 and the example tire of FIG. 12;

FIG. 14 is a schematic perspective view of the example assembly of FIG. 6 and the example tire of FIG. 12; and

FIG. 15 is a schematic perspective view of the example assembly of FIGS. 9 & 10 and the example tire of FIG. 12.

DESCRIPTION OF EXAMPLES OF THE PRESENT INVENTION

A conventional tire assembly, such as that described in US 2004/0069385 and U.S. patent application Ser. No. 15/615, 888, incorporated herein by reference in their entirety, and may have an outer ring, such as a shear band, flexibly connected to a central hub by means of lightweight composite springs. The springs may be plates fixed to the ring and to the hub. The hub may contain a speed reduction gear unit and/or an electric motor and may have a suspension mechanism for connecting a vehicle chassis to each wheel. The ring may be constructed from a flexible composite material, such as carbon fiber reinforced nylon material and have twin rubber tires and a plurality of circumferentially spaced-apart radial cleats which engage the ground and provide improved traction. The hub may also be formed from a carbon fiber reinforced composite material. Another conventional wheel may have a rubber strip with a molded tread bonded to a composite ring for improved grip. Further, the springs interconnecting the ring and hub may be S-shaped lightweight composite springs.

Another conventional tire assembly may be formed from a lightweight composite material, such as carbon fiber reinforced polyamide. The assembly may have a cylindrical central hub and a circular outer flexible rim mounted on the central hub by an endless looped spring band extending between the central hub and the circular rim. Six radial loops may be defined by the spring band. The spring band may be attached to the central hub and to the circular rim by any suitable means, such as adhesion, cohesion, soldering and/or mechanical fixing by means of bolts, rivets, and/or clamps.

As shown in FIG. 12, an example tire assembly 300 for use with a rim in accordance with the present invention may have a spoke structure 310 defining a plurality of alternating closed egg-shaped cavities 311 and open rectangular inlet openings 312 disposed concentrically about the inner central rim allowing the spoke structure to deflect under load thereby defining a suitable balance between flexibility for ride comfort and traction within a footprint of the assembly 300 and stiffness for vehicle handling, low rolling resistance, and low heat build-up within the spoke structure. The spoke structure 310 may further define a plurality of triangular openings 345 disposed at the outer flexible ring and between the cavities 311 and the inlet openings 312 (FIG. 12).

The cavities 311 of the spoke structure 310 may further define openings for arms of an inner central rim to extend therethrough and secure the spoke structure to the inner central rim, as described above. The arms may engage portions of the spoke structure 310 in a mechanical interlocking arrangement. The inner central rim may further include plates that, along with the arms may sandwich portions of the spoke structure 310 and create a further frictional and/or adhesive securement between the inner central rim and the spoke structure. The spoke structure 310 may comprise a homogenous or heterogeneous polymer and/or a filled polymer.

Spokes 315 of the spoke structure 310 may be curved inwardly or outwardly for mitigating or enhancing buckling of the spokes. The spokes 315 may include one or more reinforcing layers 319. The layer(s) 319 may be constructed of single end dipped cords, conventional pneumatic tire ply/cord arrangements, short fibers, and/or polymeric film. Further, these constructions may be PET, nylon 6, nylon 6,6, rayon, steel, glass fibers, carbon fiber, aramid, and/or a hybrid construction of these materials. The cords may be between 400 denier to 9000 denier. The polymeric film may be from 0.1 mm to 2.0 mm thick. The reinforcement in the spokes 315 may be oriented at angle between 0 degrees and 90 degrees. The spokes 315 may be continuously reinforced across their entire axial length. Continuous reinforcement layer(s) 319 may extend radially outward to multiple locations adjacent to a shear band 343 at the outer flexible ring. Other reinforcement layers 319 may extend about the interior of the closed cavities 311. The continuous reinforcement layer(s) 319 may be integrated into the spoke structure 310 and the outer flexible ring. Alternatively, the shear band 343 may be attached to the spoke structure 310 by between 20 and 60 connection points (e.g., cohesion, adhesive, fused, welded, etc.).

Each cavity 311 and inlet opening 312 may have a common cross sectional profile about the axis of rotation of the assembly. Further, each cavity 311 and inlet opening 312 may have a common axial length equal to a uniform axial thickness of the spoke structure 310. Each cavity 311 may be curvedly shaped to prevent "pinch" points on the reinforcement layer(s) 319 and mitigate compressive stress concen-

trations on the reinforcement layer(s). The number of cavities **311** may be between 15 and 60 for large scale assemblies.

As shown in FIGS. **1-11** & **13-15**, an adjustable rim **200** in accordance with the present invention may include a support member **210** having a cylindrical hub **211** and radially protruding extensions **212** (**10** shown in FIG. **1**) projecting radially outward from the hub. The rim **200** may further include a first annular ring **220** having radially extending slots **221** (**10** shown in FIG. **1**) circumferentially spaced about the first ring and bolt holes **222** (**10** shown in FIG. **1**) spaced circumferentially between the slots. Stub bolts **230** may fasten the first ring **220** to the support member **210** (FIG. **2**).

A plurality of axially extending arcuate members **240** may be circumferentially aligned with the slots **222** of the first ring **220**. Each arcuate member **240** may have bores **241** extending axially through each arcuate member (one end shown in FIG. **3**). Shaft bolts **235** may be axially inserted through circumferentially and radially extending arcuate apertures **251** in a first rotatable annular adjustment hoop **250** (FIG. **4**), the slots **221** of the first ring **220**, and the bores **241** of the arcuate members **240** (FIG. **11**). Axial fastener nuts **260** may be fixed to the shaft bolts **235** thereby axially securing (FIG. **5**) the support member **210**/first ring **220**, the first hoop **250** (FIG. **10**), the first hoop **250**, and the rest of the rim **200**, as described below.

The bolts **235** may previously have been inserted through radially extending slots **271** of a second annular ring **270** and radially extending arcuate apertures **281** in a second rotatable annular adjustment hoop **280** (FIG. **6-7**). The nuts **260** may then be fixed to the protruding bolts **235** thereby axially securing (FIG. **7-10**) the second ring **270** and the second hoop **280** to the support member **210**/first ring **220**, and the first hoop **250** (FIG. **11**).

As shown in FIGS. **13-15**, the rim **200** may attach to the example tire **300** in a similar manner to the assembly of the rim. The steps of FIGS. **1-4** may be completed initially to form an initial assembly **1300**. Then the example tire **300** may be radially and circumferentially aligned with the assembly **1300** (FIG. **13**). Next, the steps of FIGS. **5-10** may be performed such that the arcuate members **240** of the rim **200** extend axially through the closed cavities **311** with the first ring **220** and the second ring **270** axially securing the entire rim and tire assembly **1500** together (**14-15**). Before completely tightening, or fixing, the nuts **260** to the bolts **235** to rigidly and axially connect all the parts of the assembly **1500** or after loosening, or unfixing, the nuts from the bolts, the radial tension placed on the spoke structure **310** of the tire **300** by the arcuate members **240** may be adjusted by rotating the first and second hoops **250**, **280** relative to the first and second rings **220**, **270** such that the interaction between the angled arcuate apertures **251**, **281** and the radial slots **221**, **271** first and second rings **221**, **271** move the bolts/nuts **235**, **260** and the arcuate members **241** radially inward or outward. The radial slots **221**, **271** may keep the bolts/nuts **235**, **260** and the arcuate members **241** from moving in any direction but radially. Both arcuate apertures **251**, **281** may have equal and opposite shapes and sizes such that an equal rotation in the same direction of the first hoop **250** relative to the first ring **220** and the second hoop **280** relative to the second ring **270** may produce an equal amount of radial movement at each axial end of the arcuate members **240**.

Variations in the present invention are possible in light of the description of it provided herein. While certain representative examples and details have been shown for the

purpose of illustrating the subject invention, it will be apparent to those skilled in this art that various changes and modifications can be made therein without departing from the scope of the subject invention. It is, therefore, to be understood that changes can be made in the particular examples described which will be within the full scope of the present invention as defined by the following appended claims. Further, the present invention is not limited to the examples hereinbefore described which may be varied in both construction and detail within the full scope of the appended claims.

What is claimed:

1. A method of adjusting radial tension placed on a spoke structure, the method including the steps of:
 - rolling a first annular ring about an axis;
 - fixing the first annular ring to a first annular hoop;
 - rolling a second annular ring about the axis;
 - fixing the second annular ring to a second annular hoop;
 - attaching the spoke structure to the first annular ring and the second annular ring;
 - rotating the first annular hoop relative to the first annular ring about the axis;
 - rotating the second annular hoop relative to the second annular ring about the axis;
 - moving an arcuate member radially relative to the axis; and
 - altering radial tension of the spoke structure.
2. The method as set forth in claim **1** further including the step of extending a first linear slot in the first annular ring.
3. The method as set forth in claim **2** further including the step of extending a first arcuate slot in the first annular hoop.
4. The method as set forth in claim **3** further including the step of moving an arcuate member relative to the axis by interaction between the first linear slot and the first arcuate slot.
5. The method as set forth in claim **3** further including the step of moving an arcuate member relative to the axis by circumferential and radial motion between the first linear slot relative to the first arcuate slot.
6. A method of adjusting radial tension placed on a spoke structure, the method including the steps of:
 - rolling a first annular ring and a second annular ring about an axis;
 - attaching the spoke structure to the first annular ring and the second annular ring;
 - unfixing the first annular ring from a first annular hoop;
 - unfixing the second annular ring from a second annular hoop;
 - rotating the first annular hoop relative to the first annular ring about the axis;
 - rotating the second annular hoop relative to the second annular ring about the axis;
 - altering tension of the spoke structure;
 - refixing the first annular ring to the first annular hoop; and
 - refixing the second annular ring to the second annular hoop.
7. The method as set forth in claim **6** further including the step of aligning an arcuate member circumferentially and radially with the first annular ring, the first annular hoop, the second annular ring, and the second annular hoop.
8. The method as set forth in claim **7** further including the step of rotating the first annular hoop relative to the first annular ring about the first axis.
9. The method as set forth in claim **8** further including the step of rotating the second annular hoop relative to the second annular ring about the axis.

10. The method as set forth in claim 6 further including the step of moving the arcuate member relative to the axis.

* * * * *